



AquaMetric AM-ODO Optical Dissolved Oxygen Sensor



Installation and Operation Manual

Table of Contents

1	Introduction	3
1.1	AM-ODO Overview	3
1.2	Application Notes	4
2	Specifications.....	4
3	Installation	5
3.1	Dimensions and Schematics.....	5
3.2	Wiring Instructions	5
3.3	Probe Assembly Instructions.....	6
4	Signal Output.....	8
4.1	Output Selection and Conversion	8
4.2	Salinity Compensation.....	8
5	Calibration.....	9
5.1	General Information	9
5.2	One Point Calibration.....	9
5.2.1	Calibration Procedure.....	10
6	Maintenance.....	10
6.1	Sensor Cap Maintenance.....	10
6.1.1	Sensor Cap Cleaning.....	10
6.1.2	Sensor Cap Storage	11
6.1.3	Sensor Cap Replacement	11
6.2	Probe Housing and Cables	12
7	Troubleshooting	12
8	Replacement Parts	13

1 Introduction

The AM-ODO is one of the most compact, durable and easiest to use dissolved oxygen sensors on the market. It is an optical sensor that utilizes fluorescence quenching technology. With this technology, the quenching of fluorophores by oxygen molecules dissolved in water decreases the fluorescence intensity and lifetime, which is then detected by the photodetector and allows the dissolved oxygen (DO) concentration to be quantified accurately and consistently.

Unlike polarographic and galvanic electrochemical technologies used for the measurement of dissolved oxygen, optical technology does not consume oxygen during measurement. Also, optical technology does not require filling solutions, a “warm-up” period, nor sample flow. The measured dissolved oxygen concentration is automatically compensated for by integrated data from the temperature and pressure sensors and sophisticated algorithms in the firmware.

User selectable outputs include 4-20 mA or 0-5 V for the 0-20 mg/L oxygen concentration range corresponding to saturation range of 0-200%.

1.1 AM-ODO Overview

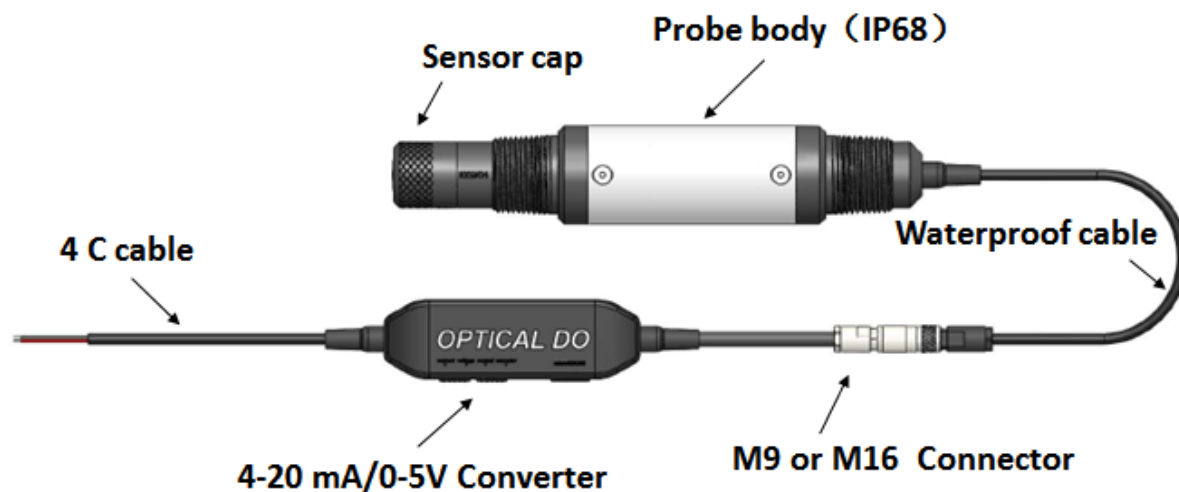

Fig. 1: AM-ODO Probe and Peripherals

The following parts are required for the proper operation of the AM-ODO probe:



Sensor Cap: Produces fluorescence correlated to the dissolved oxygen concentration.



MicroSD Card: Contains the data and other parameters to enable the sensor cap to work properly.

NOTE: Each sensor cap has its own unique microSD card. The sensor cap **MUST** be used in conjunction with the microSD card with which it was shipped. Check the serial numbers printed on the side of the sensor cap and the face of the microSD card to ensure the serial numbers match.

1.2 Application Notes

1. The IP68 waterproof rating listed in this Installation and Operation Manual applies only to the probe itself. While the cable is considered water resistant (ref. Fig. 1 above), it should be protected from continuous water ingress in the long term. For example, in submersible applications, it should be protected by running it through a pipe using the 1" NPT fitting at the back-end of the probe. As also seen in Fig. 1, note that the converter is not waterproof due to its integral pressure sensor and should not be submersed or exposed to water spray.
2. A temperature sensor is built into the probe body, close to the sensor cap. It should be completely immersed in the sample when taking measurements.
3. The sensor cap should be handled and used with care. Avoid scratching the surface coating and avoid contact with acetone, THF, and any other strong organic solvents.
4. For improved accuracy and quick response, store the probe and attached sensor cap in the calibration bottle (or storage bottle) before and after use.

2 Specifications

Technical Specifications

Sensor Type	Optical	Fluorescent Phase Measurement
Dissolved Oxygen (Saturation %)	Measurement Range Accuracy Resolution	Saturation: 0 to 200% ±1.0% (0 to 200%) 0.1%
Dissolved Oxygen (mg/L, ppm)	Measurement Range Accuracy Resolution	Concentration: 0 to 20 mg/L ±0.1 mg/L (0 to 20 mg/L) 0.01 mg/L
Temperature (°C, °F)	Range Accuracy Resolution	-5 to 50°C (23 to 122°F) ±0.2°C (±0.2°F) 0.1°C (0.1°F)
Barometric Pressure (kPa, atm)	Range Accuracy Resolution	51 to 112 kPa (0.5-1.1 atm) ±0.2 % 0.1 kPa (51-112 kPa)

Operational Specifications

Materials	PVC, ABS Plastics, Stainless Steel (customized materials available by request)
Probe Dimensions	8.9" X Ø 1.66" (226.06mm X 42.16mm)
Converter Dimensions	0.82" X 1.33" X 4.94" (20.83mm X 33.78mm X 125.48mm)
Cable Length	6, 10, 17 meters (customized lengths available by request)
Power Supply	5-16 VDC
Probe Insertion	1"NPT front & back (2.54cm)
Temperature: Operation Storage	-5 °C to 50 °C -5 °C to 50 °C (avoid prolonged temperature extremes)
Operation Pressure	Tested to 60PSI
Sample Flow	Not needed
Salinity Input Range	0 to 50 ppt
Response Time	40 seconds to 90% of the final reading (T90)

3 Installation

The AM-ODO probe consists of two major parts: the probe itself and the signal output converter or Universal Interface Board (UIB). They are connected by a M9 or M16 connector to allow the probe cable to be threaded through a pipe or conduit in submersible applications.

This installation procedure includes the assembly of the probe and how to connect it to any analyzers, controllers or meters that allow for 4-20mA or 0-5V output. Refer to the instructions below, as well as the controller/analyzer manual for proper installation and operation instructions.

3.1 Dimensions and Schematics

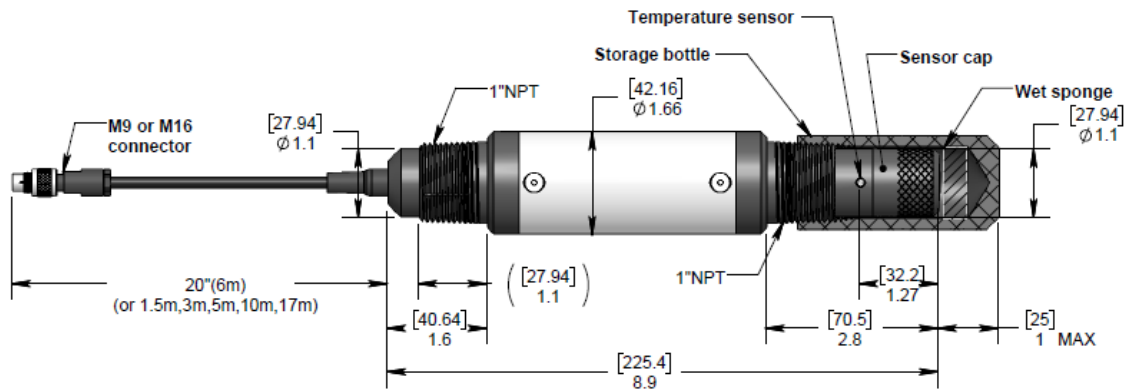

Fig. 2: AM-ODO Schematic

3.2 Wiring Instructions

Fig. 3: AM-ODO Wiring Color Scheme



WIRE	COLOR	DESCRIPTION
#1	Red	Power (+)
#2	Black	Power (-) and grounding for signal output
#3	Green	Concentration "mg/L" (0-5V or 4-20mA)
#4	White	Saturation "%" (0-5V or 4-20mA)

Note:

- Power supply: 5-16VDC. Make sure to follow the wiring instructions above and provide the proper power specification. Connecting the probe to any power outside the normal range may result in damage and may void the warranty.
- Output: Analog 4-20mA or 0-5V for the range 0-20mg/L and saturation 0-200%.
- Pressure sensor operational range: 51-112 kPa (0.5-1.1 atm).
- Converter box (UIB): Not waterproof; it should not be submersed or exposed to water spray for any extended period.

3.3 Probe Assembly Instructions

Safety Notice:



- Make sure the probe is not powered during assembly.
- Safety glasses and gloves are recommended.
- Perform this assembly on a clean table with soft paper towels available.

1. Check to ensure you have the necessary components:



- A: Sensor cap with matching microSD card
- B: Calibration/storage bottle with wet sponge
- C: AM-ODO probe
- D: Converter box (UIB)

Note: Every AM-ODO is shipped with a sensor cap installed and the matched microSD card inserted in the card slot of the converter box, respectively.

2. Open the microSD card cover on the converter box (UIB):

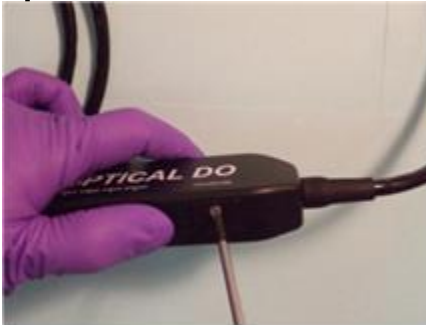

- Use a small Philips screwdriver.

3. Insert the microSD card into the microSD card slot:



- Push to lock the card in the slot. Avoid using any sharp-tip tools for this positioning step.

Note: The microSD card MUST be the one that was shipped with the Sensor Cap. The serial numbers printed on the microSD card and the sensor cap must match.

4. Lock the microSD card cover with the screwdriver:



- When replacing the sensor cap, unlock the microSD card cover and replace the old microSD card with a new one that is matched to the new sensor cap. Check to ensure the serial numbers match.

5. Screw the sensor cap onto the probe:



- *DO NOT touch the clear window on the probe tip. If any contaminants or residue is present on the window or inside the cap, carefully remove them with a powder free wipe.*
- *DO NOT over tighten or use any tool, just tighten the sensor cap to finger-tight fit.*

6. Connect the probe to the converter box (UIB) via the M9 4-pin connector set

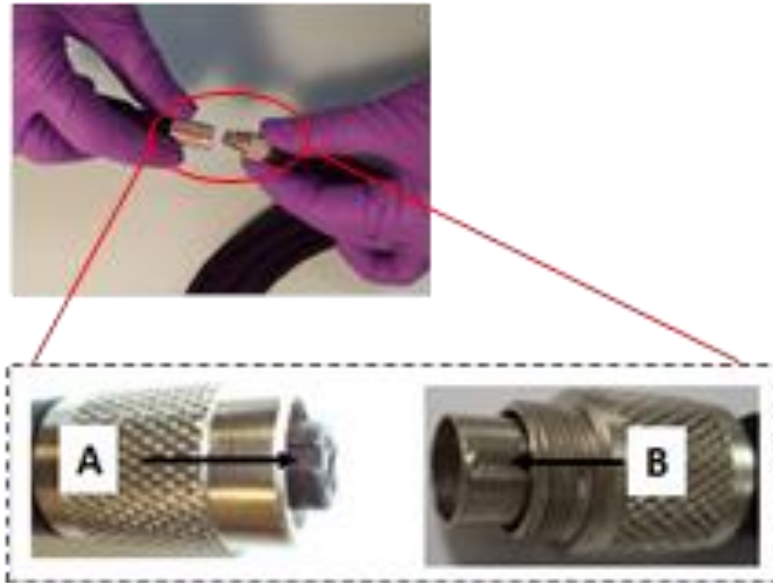

Note: *Be sure to position the connector groove A to B as shown above, then push in and thread the outer cover to tighten).*

7. Lightly screw the calibration/storage bottle onto the probe:



- *Make sure the sponge inside the bottle is wet enough to effectively create a 100% water saturated air environment (humidity chamber) for the sensor membrane.*

Note: *Use tap water to clean the sponge if it becomes dirty or biofouling (mold growth) occurs.*

4 Signal Output

4.1 Output Selection and Conversion

Two output modes are available for the AM-ODO probes: Analog 0-5V and analog 4-20mA. The conversion equations between concentration “mg/L” (or saturation “sat.%)” and voltage (0-5V) or current (4-20mA) are as follows:

- **Select “voltage” on the converter (UIB) switch for 0-5V output:**

$$\text{DO Concentration (mg/L)} = 4.1667 \times V - 0.4167 \quad [V = \text{Voltage readings between wire \#2 and \#3}]$$

$$\text{DO Sat.\%} = (0.4167 \times V' - 0.0417) \times 100\% \quad [V' = \text{Voltage readings between wire \#2 and \#4}]$$

- **Select “current” on the converter (UIB) switch for 4-20 mA output:**

$$\text{DO Concentration (mg/L)} = 1.25 \times I - 5 \quad [I = \text{Current readings between wire \#2 and \#3}]$$

$$\text{DO Sat.\%} = (0.125 \times I' - 0.5) \times 100\% \quad [I' = \text{Current readings between \#2 and \#4}]$$

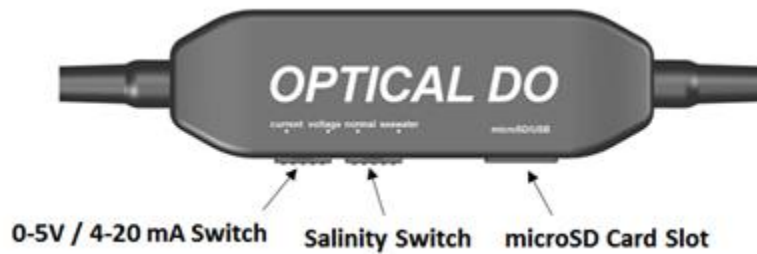

Fig. 4: 0-5V/4-20mA Converter

4.2 Salinity Compensation

The AM-ODO probe’s dissolved oxygen measurement can also be compensated for seawater (salinity compensation) since salts affect the solubility of oxygen in water. On the converter box (UIB) select “normal” for no salinity compensation (e.g. freshwater applications), and “seawater” for salinity compensation at typical sea or ocean water salinity concentrations.

Note that the saturation% of DO will not be influenced by selecting either the fresh water or seawater setting, however the DO concentration (mg/L) will be compensated if “seawater” mode is selected. If manual salinity compensation is desired, a compensation factor “S” can be used to correct the DO concentration “mg/L” in salt water as follows:

$$\text{DO “mg/L” (after correction)} = \text{DO “mg/L” (before correction)} \times S$$

Compensation factor, $S = ex$

Where,

$$x = (- [ppt] \times (0.017674 + (-10.754 + 2140.7/T)/T))$$

Salinity is in parts per thousand (ppt) and temperature is in Kelvin (K).

For example, in freshwater (“normal” mode), salinity is 0 ppt and $S=1$, while in seawater mode (assuming the salinity level is 35 ppt), the factor is $S = 0.816$ (at 22°C).

The conversion equation between salinity (in ppt) and specific conductance (SC in $\mu\text{S/cm}$) is:

$$\text{ppt} = 5.572 \times 10^{-4}(\text{SC}) + 2.02 \times 10^{-9} \times (\text{SC}) \times (\text{SC})$$

5 Calibration

5.1 General Information

The AM-ODO sensor system is based on fluorescence quenching technology utilizing a light-sensitive coating that is permeable to dissolved oxygen. This technology is recognized as being more accurate and more stable than polarographic or galvanic technology electrodes. For the best accuracy, it is recommended to calibrate the sensor before putting it into service and to conduct a systematic stability evaluation to determine the best ongoing calibration method, frequency, and secondary comparison method if your application requires. Consult with the 4-20mA/0-5V calibration procedure for your meter/instrumentation, as well as the information below, to calibrate this probe.

Dissolved oxygen (DO) levels are also directly influenced by the local Temperature (T), Barometric Pressure (BP) and, as noted above, Salinity (S). Some notes on these influences are as follows:

- **Temperature (T):** This probe uses the temperature sensor to automatically compensate for the measured dissolved oxygen concentration.
- **Barometric Pressure (BP):** This probe has a pressure sensor in the UIB assembly and the pressure measurement is used to automatically compensate for the measured dissolved oxygen concentration.
- **Salinity (S):** Salinity is defined as the salts, such as sodium chloride, magnesium and calcium sulfates, and others dissolved in the water sample. Since an increase in salinity will decrease the solubility of oxygen in water it is important to compensate the measurement for salinity in many applications. The DOP1-Series probe has a preset salinity compensation option to address this for seawater and similar applications. (See Section 3.2 Salinity Compensation above). Set the switch to seawater to compensate at an approximately 35 ppt salinity value (this is a typical seawater salinity concentration). Alternatively, set the switch to freshwater, and the salinity compensation is turned off. In freshwater mode, the DO measurements can be compensated for salinity manually if desired.

For first time use of the AM-ODO, please note:

- If the sensor cap portion of the probe was not stored in a humid chamber (such as the included calibration/storage bottle with wet sponge) install the sensor cap on the probe and allow it to soak in a beaker of clean water overnight.

5.2 One Point Calibration

The AM-ODO sensor system only requires a one point (1-pt) calibration. A 1-pt calibration for the 100% saturation (or upper limit) situation can be created by one of the following means:

Air-saturated water: Continuously purge water with air using an air bubbler or some type of aeration until the water becomes completely saturated with air (about 10 minutes). Immerse the sensor cap and temperature sensor in the air-saturated water, and wait until the reading becomes stable.

Water-saturated air: Alternatively, a 1-pt calibration can be done using water-saturated air: Install the sensor end in the calibration/storage bottle with a wet sponge and some water inside. Avoid direct contact of the sensor cap with any water in the calibration/storage bottle during this calibration step:

- Loosely screw the calibration/storage bottle onto the probe. Be careful not to completely tighten the bottle on the probe to ensure the pressure inside the calibration/storage bottle is the same as ambient pressure.
Note: You should hand-tighten the calibration/storage bottle for storage, but for calibration it is important to loosen the cap to maintain equal pressure inside the calibration/storage bottle.
- Wait 15 minutes to ensure that the saturation (or relative humidity) in the calibration/storage bottle will be 100%. It for the readings to stabilize. Ensure the following during this step:

5.2.1 Calibration Procedure

1. Follow the sensor assembly and installation instructions (see Section 2: Installation), then connect the probe to an appropriate meter or controller. Select the proper output: either 0-5V or current 4-20 mA; then set the salinity switch on the converter box to "normal."
2. Provide 5-16 VDC to power the probe.
3. Place the probe into 100% air-saturated water and wait for at least 2 minutes to stabilize the probe (or in water-saturated air, refer to Section 4.2: One-point Calibration).
4. Use a paper clip or similar tool (avoid using anything sharp) to press the calibration button on the back of the converter (the hole is marked as "CAL", see the gray arrow below), Hold this button for at least 3 seconds.



5. After the calibration process is complete, the voltage/current output from the converter will be calibrated to 2.5V (voltage output) or 12 mA (current output), respectively, corresponding to the standard saturation 100%.

6 Maintenance

The AM-ODO probe comes with a calibration/storage bottle, a sensor cap, and a microSD card. It is very important to note that the microSD card stores the basic parameters needed for the sensor cap with which it is associated (and shipped). Each sensor cap works only with the specific microSD Card that has been programmed for it. Do not attempt to use a sensor cap with any microSD card other than the one that shipped with it. A mismatched microSD cards/sensor cap set will not function properly, and will result in data inaccuracy. Maintenance of DOP1-Series probe includes cleaning the sensor cap, and the proper conditioning, preparation and storage of the whole test system. (Note that the set-up and maintenance of the meter or controller is not included in this Manual).

6.1 Sensor Cap Maintenance

6.1.1 Sensor Cap Cleaning

The AM-ODO sensor cap is manufactured from a special plastic to which a proprietary coating is applied. While minor fouling of the sensor cap will not affect the measurement accuracy, keeping the sensor cap clean after each use will extend its lifetime. To clean the sensor cap:

1. Thoroughly rinse the probe and sensor cap with clean water.
2. Use a tissue or lab wipe to gently wipe any bio growth or fouling from the sensor cap surface. Avoid using chemical cleaners or other substances.

6.1.2 Sensor Cap Storage

When the probe is not in use, it is highly recommended to store the probe with its sensor cap installed and the calibration/storage bottle that was included in the package, threaded onto the probe. A beaker of clean water or a moist/humid capping mechanism can also suffice if the calibration/storage bottle is not available. The sponge inside the calibration/storage bottle should be kept wetted for best results. If the calibration/storage bottle is lost, broken or missing the sponge please request a new one right away. This storage protocol will make the probe respond faster when taking measurements.



AM-ODO Probe

Calibration/Storage Bottle

Metal Guard Protector

Note: The calibration/storage bottle is used for probe storage and general protection. It also is an excellent way to create the 100% water-saturated air calibration point if air-saturated water is not available. A wet sponge inside the bottle is necessary to create this situation.

- For short-term storage (less than 1 week) or for frequent usage (i.e. daily use), the probe can be stored in water or in water-saturated air (humidity chamber). The former can be attained with a beaker or other container with clean water in it, and the humidity chamber can be created by using the calibration/storage bottle with a wet sponge or similar capping device.
- For long-term storage (>2 weeks), place the probe into the calibration/storage bottle with a wet sponge and inspect the sponge to make sure it is not dried out. Without humidity, or a wetted situation, the DO readings will drift slightly at the beginning of next usage until the sensor cap is fully hydrated. It is recommended to recalibrate after an extended dried out condition.

6.1.3 Sensor Cap Replacement

When: With proper care and recommended use conditions, the DOP1-Series sensor cap can provide accurate measurements for more than two years, even with minor mechanical or chemical damage. However, it is recommended that the sensor cap be replaced after two years, or earlier if it becomes difficult to calibrate, slow to respond or damaged.

How: To replace the sensor cap, first unscrew (counterclockwise) the old or damaged one from the probe. Avoid using tools as that may damage the probe threads. Then, follow the procedure below:

- Check the o-ring on the probe above the threaded portion. If the o-ring is not in the right position or twisted, reposition it.
- Open the new sensor cap package and carefully inspect the cap - make sure the inside is clean and completely dry. If it is not, use a tissue or lab wipe to clean and dry it.
- Place the new sensor cap onto the probe and tighten it (clockwise) until it is finger-tight (do not use tools).
- After a new sensor cap is installed, condition the new cap by placing it in a beaker of clean water (fast conditioning) or in the calibration/storage bottle with a wet sponge (slower conditioning).
- Insert the microSD card (specific for the replacement sensor cap) into the microSD slot on the converter (UIB). The serial number on the sensor cap must match the serial number on the microSD card.
- Calibrate the new sensor cap (Refer to Section 5.2: One Point Calibration), configure the probe and begin taking measurements.

6.2 Probe Housing and Cables





The AM-ODO probe is IP68-rated so it can be used to measure dissolved oxygen in submersible applications depending on the cable length. Since some water types may contain materials that could erode or deteriorate the cable jacket, it is best to route the cable through pipe using the back 1" NPT threads, protecting the cable in submersible applications. Contact your supplier to order accessories such as longer cable lengths, metal guards, and replacement sensor caps as needed.

The AM-ODO probe housing is constructed from PVC/stainless steel materials. All plastic (PVC) options are also available. Avoid any strong organic solvents, such as acetone, THF and toluene when cleaning. These substances will decrease the life of the probe if present in your sample. Mild solvents like ethanol or isopropanol may be used to clean the housing if it gets dirty or fouled by organic residues, paints, or other materials.

7 Troubleshooting

Observation	Cause/Action
<i>Unstable Reading (DO or Temp.)</i>	<i>The probe's temperature sensor requires approximately 5 minutes to reach equilibrium and become stable due to the thick and robust body housing on the AM-ODO probe. As a result, the output (concentration of DO) also requires approximately 5 minutes to stabilize when the measurement environment is changing or has changed quickly.</i>
<i>Inaccurate DO Reading</i>	<i>If the DO reading is obviously lower than expected, check the salinity switch on the converter box to ensure that the switch is in the correct position ("normal" for freshwater applications; "seawater" for ocean/saltwater applications). Also, be sure to check that the "current/voltage" switch is in the correct position (see Section 3. Converter Installation).</i> <i>If the probe tip (sensor cap) touches a container bottom or other surface area not intended to be measured, the DO equilibrium between the water sample and the sensor cap coating may be affected, resulting in inaccurate readings.</i>
<i>Low or No Output</i>	<i>If you experience a zero DO concentration or saturation reading (corresponding to an output current of 3.990 ~ 4.009 mA), please check the connection to converter and the M9/M16 connectors.</i> <i>If the output is very low (for example, current lower than 3.990 mA) or there is no output at all, the probe and the converter should be returned to your supplier. This error could be caused by rewiring the PCB in the converter, connecting the sensor end wires incorrectly, or touching the four wires (causing a short circuit). Rewiring or modification is discouraged (and may void warranty), but, if necessary, any rewiring or electronics modifications should only be performed by skilled technicians exercising extreme caution.</i>

8 Replacement Parts

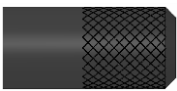
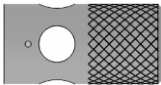
	Description	Part#
	<p>AM-ODO system (1 sensor cap and microSD card included)</p>	<p>AM-ODO</p>
	<p>Sensor cap with microSD card (1 Sensor cap with matched microSD card)</p>	<p>AM-ODO-CAP</p>
	<p>AM-ODO probe only (M9 connector)</p>	<p>Contact Supplier</p>
	<p>Converter box (UIB) (M9 connector)</p>	<p>Contact Supplier</p>
	<p>Calibration/Storage Bottle (Sponge included)</p>	<p>AM-ODO-CAL</p>
	<p>Metal Guard Protector</p>	<p>AM-ODO-MPR</p>



Water Analytics, Inc.

100 School Street

Andover, MA 01810

www.AquaMetrix.com

978-749-9949