



F250 Mk II Precision Thermometer

Operator's Handbook F250-14-002 Issue 6

Isotech North America
154 Brentwood Drive, Unit 3
Colchester, VT 05404

Phone: (802) 863-8050
Fax: (802) 863-8125

Email: sales@isotechna.com
Web: www.isotechna.com

GENERAL

This instrument has been designed and tested to comply with the Electromagnetic Compatibility Directive 89/336/EEC and Low Voltage Directive 93/68EEC in accordance with EN 61010 -1 :1995 relating to the safety requirements for electrical equipment for measurement, control and laboratory use.

Before connecting the instrument to the mains supply please ensure the following safety precautions have been read and understood.

SAFETY SYMBOLS

The following symbols are used to describe important safety aspects of this instrument, these symbols appear on the instrument and in the operation instructions.



Attention Symbol: Indicates a potentially hazardous condition exists and that it is necessary for the operator to refer to the instruction manual to ensure the safe operation of this instrument.



Hot Surface Warning: Indicates a hot surface that may be at a temperature capable of causing burns, refer to the instruction manual for further safety information.



Caution Risk of Electric Shock: Indicates hazardous voltages may be present, refer to the instruction manual for further safety information.



Protective Conductor Terminal: For protection against electrical shock during a fault condition. This symbol is used to indicate terminals that must be connected to electrical ground before operating equipment.

SUMMARY OF SAFETY PRECAUTIONS

The following general safety precautions must be observed while operating or servicing this instrument. Failure to comply with these precautions may result in personnel injury or death.

INSTRUMENT ELECTRICAL EARTH

This instrument is designed as a Class 1 electrical safety insulation device. To ensure continued protection from electric shock the instrument chassis must be connected to an electrical ground. The instrument is supplied with an AC power cable with an earth connection.

LIVE CIRCUITS DANGER

Do not connect the power supply to or operate this instrument with the protective covers removed. Component replacement and internal adjustments must be made by qualified service personnel. Do not replace components with the power cable connected. Under certain conditions, dangerous voltages may exist with the power cable removed. To avoid injuries always disconnect power and discharge circuits before touching them.

DO NOT MODIFY THIS INSTRUMENT OR SUBSTITUTE PARTS

Because of the danger of introducing additional hazards; do not perform any unauthorized modification or install substitute parts to the instrument. Only fuses with the rated current, voltage and specified type should be used, failure to do so may cause an electric shock or fire hazard. Return the instrument to Automatic Systems Laboratories for service and repair to ensure the safety features are maintained.

DO NOT OPERATE IN EITHER DAMP OR EXPLOSIVE ENVIRONMENTS

This instrument is not designed to operate while wet, in an environment of condensing humidity or in the presence of flammable gases or vapors. The operation of this instrument in such an environment constitutes a safety hazard.

HOT SURFACES DANGER

Equipment marked with a Hot Surface warning symbol should be regarded as operating at temperatures capable of causing burns. Do not touch, handle or transport hot components or liquids until they are at safe temperatures. Care should be taken not to spill or splash water or volatile fluids on or into hot surfaces or liquids.

CERTIFICATION

Automatic Systems Laboratories certifies that this product met its published specifications at the time of shipment from our factory. All calibration measurements performed in the manufacture of this instrument are traceable to the National Physical Laboratory (London).

ASSISTANCE

For after sales support and product service assistance please contact Automatic Systems Laboratories Customer Support Group. Contact information is provided in the operation instruction manual.

Table Of Contents

1. Introduction	5
1.1 Description	5
1.2 Definitions and Terminology used in this Manual	6
1.3 Basic Principles Of Operation	6
2. Parts Of The Thermometer	7
2.1 Front Panel.....	7
2.1.1 PRT Input Connectors A and B	7
2.1.2 Data Entry Keypad.....	8
2.1.3 Display	8
2.1.4 Main Selection Switches.....	8
2.1.5 Units.....	8
2.1.6 Run / Cal.....	8
2.2 Rear Panel	9
2.2.1 AC Power Input Socket	9
2.2.2 Power ON/OFF switch.....	9
2.2.3 Digital/Analogue Output Options	9
2.2.4 Expansion Port	9
2.2.5 PRT Input Connectors A and B	10
2.2.6 Chassis Terminal.....	10
3. Installation	10
3.1 Power Supply Connection.....	10
3.1.1 Setting the Voltage and Fuse Rating.....	10
3.1.2 Power On Start Up Display.....	11
4. Operating the F250 Thermometer	11
4.1 Normal (RUN) Operation	12
4.1.1 PRT Input Selection.....	12
4.1.2 Zero/Hi-Res Functions Selection.....	12
4.1.3 Dim/Bright Display Selection	13
4.2 Calibration Data Entry (CAL) Operation	13
4.2.1 Data Entry Options	14
4.2.2 General Rules for Data Entry	14
4.2.3 Starting the Data Entry Routine - For all 5 Conversion Methods	15
4.2.4 Completing the Data Entry	16
4.2.5 ITS-90 Data Entry.....	17
4.2.6 Callendar van Dusen (using Co-efficients).....	18
4.2.7 DIN Standard (IEC 751)	19
4.2.8 Callendar van Dusen - (using data pairs).....	20
4.2.9 DIN ₉₀ (BS EN 60751)	21
4.2.10 General Comments.....	21
4.3 Calibration Data Review (CAL) Operation	22
4.3.1 General Rules for Data Review	22
4.3.2 Starting the Data Review Routine - For all 5 Conversion Methods.....	23
4.3.3 ITS-90 Data Review.....	24
4.3.4 Callendar van Dusen Data Review (using Co-efficients)	25
4.3.5 DIN Standard Data Review	26
4.3.6 Callendar van Dusen Data Review (using data pairs)	26
4.3.7 DIN ₉₀ Data Review (BS EN 60751)	27
4.3.8 General Comments.....	27
5. Working with the SB250-8 or SB250-16 switchbox.....	28
5.1 Connection and Control	28

5.1.1 Switchbox Address	28
5.1.2 Connections	28
5.1.3 Power On	29
5.2 PRT Data Entry	29
5.3 PRT Data Review	29
6. Calibration	29
6.1 F250	29
6.2 PRTs	30
7. Sensor Information	30
7.1 High "alpha" PRTs	30
7.2 Low "alpha" PRTs	30
8. International Temperature Scale	31
9. Communications / Output Options	32
9.1 Fitting the Interface	32
9.2 RS232C Interface	33
9.2.1 Pin Connections	33
9.2.2 RS232C Settings	34
9.2.3 Command Delimiters	36
9.2.4 Multiple Commands	36
9.2.5 Data Timing	36
9.2.6 Returned Data	36
9.2.7 Commands and Syntax	37
9.3 IEEE488 Interface	39
9.3.1 Pin Connections	40
9.3.2 IEEE488 Address Selection	40
9.3.3 Specification	41
9.3.4 Command Delimiters	41
9.3.5 Multiple Commands	41
9.3.6 Data Timing	41
9.3.7 Commands and Syntax	42
9.4 Command "M" (Service Request Mask)	44
9.4.1 On-line Reading Display	44
9.4.2 Service Request Options	44
9.5 Analogue Output	45
9.5.1 Default Settings	45
9.5.2 Scaling Factor	46
9.5.3 Analogue Output Connection	46
9.5.4 Analogue Output Operation	46
10. Error Codes	47
11. Options and Accessories	48
11.1 Communications/Output Options	48
11.2 Accessories	48
11.3 High ∞ PRTs	48
11.4 Low ∞ PRTs	49
12. Specifications	50
12.1 Accuracy	50
12.2 Resolution	50
12.3 Stability	51
12.4 General Features	51
12.5 Measurement Range	51

12.6 Environment 51

13. Cleaning and Maintenance..... 52

13.1 Cleaning 52

13.2 Preventive Maintenance 52

13.3 General safety Warning 52

14. Service and Warranty 53

14.1 Technical Support 53

14.2 Returned Instruments 53

14.3 Documentation 53

14.4 Repair Quotations 53

1. Introduction

1.1 Description

The F250 Precision Digital Thermometer, is based on AC bridge technology, the performance and multi-channel capabilities of which make it ideal for a wide range of applications.

The F250 operates with a range of 4-wire Pt100 (100 Ohm), Pt25.5 (25.5 Ohm) and Pt10 (10 Ohm) Platinum Resistance Thermometers (PRT) to provide temperature measurement in °C, °F, K (Kelvin) plus resistance in Ohms.

The AC Resistance Ratio Bridge technology provides a basic accuracy for the instrument alone of ± 4 m Ω , equivalent to ± 10 mK with Pt100 (see temperature equivalents below), or up to ± 20 mK with calibrated Pt100 PRTs.

Overall system accuracy will depend on the quality of PRT used (see section 12 for detailed specifications).

Temperature Equivalents:

$$1 \text{ milli-degree C} = 0.001^\circ\text{C} = 1\text{m}^\circ\text{C} = 1\text{mK} = 1.8\text{m}^\circ\text{F}$$

$$1 \text{ milli-degree F} = 0.001^\circ\text{F} = 1\text{m}^\circ\text{F} = 0.56\text{mK} = 0.56\text{m}^\circ\text{C}$$

The F250 Precision Thermometer has a useful range of features.

Two measurement inputs A & B are provided, enabling A, B, or their difference A-B, to be displayed. Both A and B inputs will operate with 8 or 16 channel (models SB250-8 and SB250-16) switchboxes, enabling up to 32 PRTs to be used. The SB250-8 and SB250-16 switchboxes are a specially designed option for the F250.

When calibrated PRTs are used with the F250, either with or without switchboxes, the calibration data can be entered via the keypad on the front panel, from where it is stored in internal memory. Stored PRT calibration data may also be reviewed. A fuller description of the data entry and review options available to the user can be found in Section 4.

Security is important for data entry and a key operated switch on the front panel helps to ensure that only authorized personnel can access the calibration mode.

Finally, the front panel also incorporates a "Zero" button to allow A, B or A-B displays to be set to zero, to enable single channel or differential mode to be displayed relative to a set point.

Optional accessories for the F250 include RS232C and/or IEEE488 computer interfaces, a scaleable analogue output for recording to chart or other types of recorders and the 8 or 16 channel input switchboxes (models SB250-8 and SB250-16) as described above.

1.2 Definitions and Terminology used in this Manual

- i) $1^{\circ}\text{C} = 1\text{K}$
- ii) $1 \text{ mK (milli-Kelvin)} = 0.001^{\circ}\text{C}$ (one millidegree Celsius)
- iii) All push button actions are shown by square brackets [], for example pressing the ENTER button is shown [ENTER]
- iv) Alpha, or α , is the temperature coefficient, or temperature sensitivity, of the Platinum wire used in PRTs. Generally speaking, the higher the alpha value, the better the PRT.
- v) As the F250 has PRT "inputs" which are also used for connection to multi-channel switchboxes, which also have PRT "inputs", it is useful to differentiate between them. In this handbook, "inputs" on the F250 are referred to as Inputs and "inputs" on the switchboxes are referred to as Channels.
- vi) PRTs are regularly referred to with several alternative abbreviations as follows:
 - PRT (Platinum Resistance Thermometer)
 - Pt100 (PRT with nominally 100Ω resistance at 0°C)
 - RTD (Resistance Temperature Device)Platinum resistance thermometers may also be referred to as probes or sensors.
- vii) System accuracy refers to the overall, combined accuracy of the F250 and the PRT in use.

1.3 Basic Principles Of Operation

F250 operates with a range of platinum resistance thermometers (PRTs) by first measuring the ratio (n) of their resistance (R_t , PRT resistance), to that of a very stable internal reference resistor (R_s , standard resistance). The instrument is calibrated with its reference resistor so that it is able to determine very precisely, using $n = R_t/R_s$, the actual resistance of the PRT connected to a PRT input.

For PRTs, the relationship between resistance and temperature varies slightly from one PRT to another. Therefore no matter how accurately the F250 measures the PRT resistance, if we do not know the relationship between resistance and temperature for a particular PRT, we will not be able to accurately measure temperature.

Model F250 uses PRT calibration data to overcome this problem and creates a "look-up" resistance to temperature conversion table, stored in EPROM non-volatile memory (memory which retains its information, even when the power supply is removed) within the instrument. The look-up table enables the F250 to convert resistance accurately to temperature, uniquely for each PRT used (up to 32 when SB250-8 or SB250-16 switchboxes are connected). It is very important therefore that PRTs are used on their correct Input or Channel for accurate measurement.

The system accuracy is a combination of the F250 accuracy in measuring PRT resistance and the calibration uncertainty placed on the PRTs by the calibrating laboratory. For ASL PRTs type T100-250-1 and T100-450-1, this value is $\pm 0.025^{\circ}\text{C}$ for temperatures from -50°C to $+250^{\circ}\text{C}$.

2. Parts Of The Thermometer

2.1 Front Panel

Figure 2-1 shows the F250 front panel.

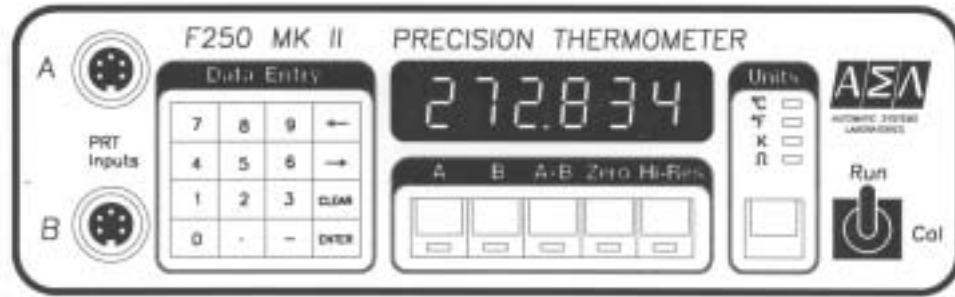

Figure 2-1. Front Panel

2.1.1 PRT Input Connectors A and B

5 pin DIN sockets allow the connection of suitable PRTs to the F250. Connection details are shown in Figure 2-2

Note: Each front panel input is connected in parallel to a 5 pin terminal socket on the rear panel for use with 4 wire PRTs without DIN plugs. Therefore Input A must have a PRT connected only to the front socket **OR** to the back socket, **NOT** to both; similarly for Input B. However it is permissible to have a PRT connected to the front socket of Input A and a PRT connected to the rear socket of Input B and vice versa.

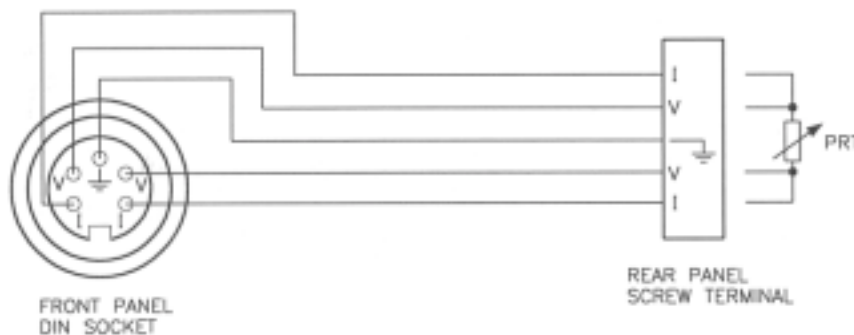

Figure 2-2. PRT Input Connectors

2.1.2 Data Entry Keypad

The 16 key keypad permits entry of data into the F250 memory. It operates in conjunction with visual instructions displayed on the instrument readout and is used primarily for entering PRT calibration data. The Run/Cal key switch (see Section 2.1.6) is provided to ensure that the PRT calibration data entry feature is accessible only to authorized personnel. Other functions provided by the keypad include dim/bright control of the display, using the left/right arrows respectively, (←/→).

2.1.3 Display

The display is a 6-digit numeric, vacuum fluorescent display. Since the 6 digits include the minus (-) sign for negative temperatures, temperatures lower than -99.999°C/F will be limited to a precision of two decimal places, for example -100.00°C/F. To obtain a precision of three decimal places in this instance, switch to K (Kelvin) as this requires no minus (-) sign.

2.1.4 Main Selection Switches

- | | |
|--------|---|
| A | Selects the PRT connected to PRT Input socket A (front or back panels) for display. |
| B | Selects the PRT connected to PRT Input socket B (front or back panels) for display. |
| A-B | Selects PRT inputs A and B alternately to display the difference between A and B PRTs. |
| Zero | Stores the present F250 reading, nulls the display and indicates any variations relative to the stored value. |
| Hi-Res | Sets the F250 to high resolution mode: 0.001°C, 0.001°F, 0.001K or 0.001Ω (Ohms). |

Measurements <1000 = 0.001°C, 0.001°F, 0.001 K or 0.001Ω (Ohms)

Measurements ≥1000 = 0.01°C, 0.01°F, 0.01 K or 0.01Ω (Ohms)

2.1.5 Units

Selects display units °C, °F, K or Ω (Ohms). Continuous operation of the Units switch cycles the selection top to bottom.

2.1.6 Run / Cal

This key operated switch allows the operator to enter the PRT calibration data. Temperature/resistance "data pairs" or calculated PRT Co-efficients for PRTs connected to Inputs A, B and up to 8 PRTs connected to each Input via the SB250-8 switchboxes (total 16 input channels) or up to 16 PRTs connected to each Input via the SB250-16 switchboxes (total 32 input channels) may be entered. A temperature/resistance "data pair" is a value for temperature and the equivalent resistance value for that PRT at that temperature. The calibration data is used to produce an internal conversion table unique to that PRT, enabling accurate conversion from resistance to temperature.

2.2 Rear Panel

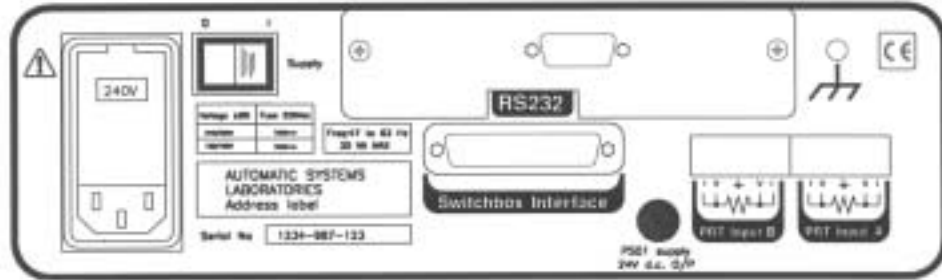

Figure 2-3. Rear Panel

2.2.1 AC Power Input Socket

Accepts an IEC type power connector.

The AC Power input unit incorporates a voltage selection tumbler, to enable the user to match the F250 to the local AC voltage supply, and two fuse holders. The correct 20mm fuses to install are as follows:

Voltage	Fuse
220/240V	T250mA (250V AC)
100/120V	T500mA (250V AC)

2.2.2 Power ON/OFF switch

I = Power ON 0 = Power OFF

The power switch itself will be illuminated (green), when the F250 power is switched ON. Care should be taken not to limit access to the power ON/OFF switch.

2.2.3 Digital/Analogue Output Options

If installed, the connectors for these are at the top of the rear panel. Depending on which options are installed and which way the Output Options board is installed, the following will be accessible:

Option	Connector
– Analogue Output only	BNC
– RS232C Interface only	9 pin D type socket
– IEEE488 Interface only	IEEE
– Analogue Output and RS232C Interface	BNC + 9 pin D type socket
– Analogue Output and IEEE488 Interface	BNC + IEEE

When the IEEE488 Interface is installed, an IEEE address select switch, for setting the F250 address in the range 1 to 7, is provided. Address 0 enables the RS232C interface.

2.2.4 Expansion Port

The expansion port connector is located below the Output Options panel.

The connector is a 25 pin D type socket for power and data connection to the SB250-8 or SB250-16 switchboxes.

2.2.5 PRT Input Connectors A and B

The rear panel screw terminal connectors are for use where 5 pin DIN plugs are not installed to PRT cables.

Note: Each rear panel input is connected in parallel to the 5 pin DIN plugs on the front panel. These are for use with 4 wire PRTs without DIN plugs. Therefore Input A must have a PRT connected **ONLY** to the front socket **OR** to the back socket, **NOT** to both: similarly for Input B. However, it is permissible to have a PRT connected to the front socket of Input A and a PRT connected to the rear socket of Input B and vice versa.

2.2.6 Chassis Terminal

The chassis terminal can be used as a common earth point by external equipment. It is connected directly to the instrument's protective conductor terminal.

3. Installation

3.1 Power Supply Connection

Checking Voltage and Fuse Rating



WARNING: DO NOT CONNECT THE POWER CABLE OR SWITCH THE UNIT ON UNTIL THE VOLTAGE AND FUSE RATING OF THE INSTRUMENT HAVE BEEN CHECKED AND CHANGED IF NECESSARY.

The supply voltage setting of the F250 is shown on the power inlet socket on the rear panel. Check that this corresponds to the local voltage and that the fuse installed is as specified in section 2.2.1.

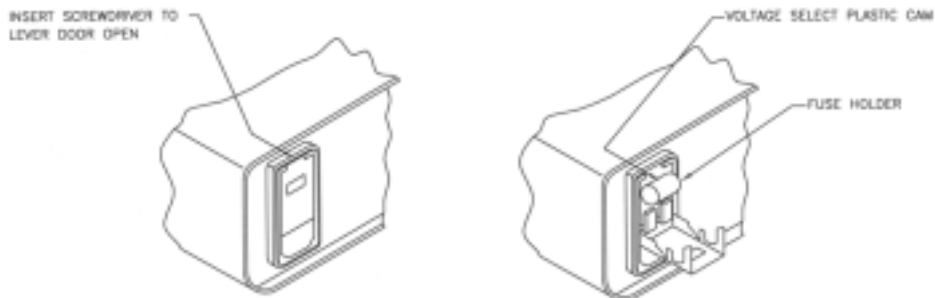

Figure 3-1. Power Input Unit and Fuse Rating Block

3.1.1 Setting the Voltage and Fuse Rating

Lever open the power input unit from the top with a flat bladed screwdriver. Inside is a plastic cam: remove this and replace it so that the voltage to be set is displayed through the window. Figure 3-1.

Where fused power plugs are connected to the supply cable provided, the correct fuse rating is 3 Amps. The supply cable provided with the F250 is colour coded as follows:

Ground	Green/Yellow (Protective Conductor Terminal)
Live	Brown
Neutral	Blue

3.1.2 Power On Start Up Display

Once you are certain that the power supply connections are correct, the voltage settings are correct and that the correct fuses have been fitted, connect the F250 to a single phase, 50/60 Hz, grounded power outlet and, with the RUN/CAL switch in the RUN position, switch ON. Initially do not connect a PRT to either input channel. After switching on, all the switch indicators, (LEDs, or Light Emitting Diodes), should be illuminated and the digital display will carry out a self test with all digits showing the number "8". Also, all the decimal points will be illuminated in turn. This is to check the integrity of the display and the display drivers. The display will next show the serial numbers entered for the PRTs normally attached to PRT Inputs A and B in the form "1 nnnn" for PRT A and "2 nnnn" for PRT B where "nnnn" represents the serial number.

The display will next show the IEEE address (if this option is installed) or "RS232". "RS232" will also be displayed if no interface option is installed or if an IEEE interface is installed with the IEEE address switch set to "0". When the display test has finished, the F250 will be set to the standard start up condition, that is PRT Input A, °C and low resolution. The display will indicate the error code "E-1", which indicates that no PRT is connected, or that an open circuit exists on PRT Input A. See Error Codes in Section 10 for a full list and description of error codes.

Now switch off the F250, connect a PRT to Input A and switch on the instrument again. After the initial display test, the display should indicate temperature in °C in low resolution. Check that the display units can be changed to °F, K and Ω (Ohms) and then back to °C by repeatedly pressing the Units switch. Check also that high resolution can be set by operating the "Hi-Res" switch and that the display can be set to zero by operating the "Zero" button. Unless a PRT is connected to Input B, operating switch B will cause an E-1 error message to be displayed, as also will operating the A - B switch. Note that in high resolution mode, the F250 will take approximately 2.5 seconds to display the first reading and subsequently to update this reading (see Specifications, section 12.2).

If any error messages other than E-1 are displayed, refer to the Error Codes in Section 10 to determine their meaning and probable cause. If no suitable explanation can be found for any fault, contact Automatic Systems Laboratories Customer Support Group.

4. Operating the F250 Thermometer

Note: 1) It is essential that PRT data, or the general purpose data (DIN), is entered into your F250 otherwise it is not possible for it to convert resistance to temperature. If no calibration data has been entered, an "E-3" message is displayed for the input or Channel selected. This can be overridden by switching the Run/Cal switch to Cal as described in section 4.2 and entering data as described.

2) The F250 now has a built-in data integrity check, which keeps an eye on the stored PRT calibration data. Every time you switch on your F250, it checks the data and, if an error is found, displays an "E-7" message. To erase the data, simply overwrite the relevant data into inputs A & B as described in section 4.2.

4.1 Normal (RUN) Operation

The F250 must be set to **RUN** on the key operated switch for all functions in the sections below. All measurements are made in RUN mode.

4.1.1 PRT Input Selection

Figure 4-1 shows the selection switches to display Inputs A and B and the differential value A - B. To select the required display, simply press the appropriate button once. For example, if you want to display the temperature measured by the PRT connected to PRT Input B, press [B]. If a SB250-8 or SB250-16 switchbox is connected to PRT Input B, then the temperatures displayed will also depend on which Channel is selected on the switchbox. See Section 5 for operation with switchboxes.

To display the differential temperature A - B press [A-B]. PRTs must be connected to both PRT Inputs, directly or via a switchbox, otherwise an error message will be displayed.



Figure 4-1. PRT Selection Switches

4.1.2 Zero/Hi-Res Functions Selection

Figure 4-2 shows the Zero and Hi-Res switches.

i) Zero

This function is used to display temperature relative to a set point. To activate Zero press [Zero] once only. When this button is pressed the value displayed is stored and subtracted from subsequent readings, until

- a) Zero button is pressed again
- b) The PRT Input is changed
- c) The Channel number is changed
- d) Units are changed

When Zero is used with the PRT Input A or B display selected, the status LED above the Zero button flashes. If the Zero facility is activated when A-B is selected, the LED lights continuously.



Figure 4-2. Zero / Hi-Resolution Switches

ii) Hi-Res

When initially powered up, the F250 displays readings to 2 decimal places in all Units. To increase resolution to 3 decimal places, press [Hi-Res] once. Press [Hi-Res] again to change resolution back to 2 decimal places. In addition to changing the display resolution, the Hi-Res button also changes the update time for the display - see Specifications (section 12).

Note that when measurements ≥ 1000 or lower than -99.999° are displayed, Hi-Res will not be able to select 3 decimal places as only 6 digits may be displayed including the minus sign. To obtain HiRes for negative temperatures, select either $^\circ\text{C}$ or K, depending on the displayed temperature.

For example $-100.000^\circ\text{C} = 173.150\text{K}$, or $-100.000^\circ\text{F} = -73.333^\circ\text{C}$.

4.1.3 Dim/Bright Display Selection

Figure 4-3 shows the switches on the keypad to select dim or bright display.

Press [←] to change the display from bright to dim.

Press [→] to change the display from dim to bright.

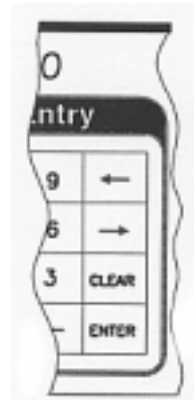

Figure 4-3. Dim / Bright Display Switches

4.2 Calibration Data Entry (CAL) Operation

The key operated switch on the F250 must be set to **CAL** for all functions in the sections below.

All data entry is performed on the 16 key keypad as shown in Figure 4-4.

See also "General comments" (section 4.2.10).

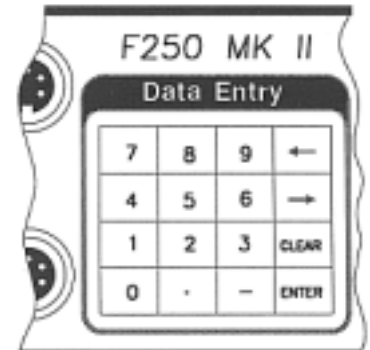

Figure 4-4. Data Entry Keypad

4.2.1 Data Entry Options

The F250 allows for 5 alternative mathematical methods of converting resistance to temperature and therefore 5 choices for entering PRT calibration data. The choice will depend on the type of PRT and its calibration. See also section 7, Sensor Information.

- i) ITS-90 Co-efficients:- intended for PRTs with high "alpha" values of 0.003926 to 0.003928, generally standards laboratory type PRTs.
- ii) Callendar van Dusen Co-efficients:- for industrial or low "alpha" PRTs of 0.00385.
- iii) DIN:- used for uncalibrated industrial PRTs with 0.00385 "alpha" value, to provide a conversion of resistance to temperature in accordance with the IEC751 standard.
- iv) Callendar van Dusen data pairs:- as (ii), but data is provided in temperature/resistance data pairs.
- v) DIN₉₀:- As (iii), but using modified co-efficients from the new British and European standard EN 60751. This brings the Co-efficients for DIN in line with ITS-90 temperatures.

The Co-efficients for DIN₉₀ are as follows:

$$A_{90} = 3.9083 \times 10^{-3}$$

$$B_{90} = - 5.775 \times 10^{-7}$$

$$C_{90} = - 4.183 \times 10^{-12}$$

$$R_0 = 100 \text{ Ohms}$$

The "alpha" value for DIN₉₀ PRTs is 0.00385055°C⁻¹.

Uncalibrated PRTs conforming to IEC751/DIN 43760/BS1904 will normally use method (iii), which provides a conversion in accordance with readily available DIN43760 or BS1904 tables. However, these tables were created using temperatures defined by the obsolete International Practical Temperature Scale of 1968 (IPTS68) and have inaccuracies in comparison with the International Temperature Scale of 1990 (ITS-90). Automatic Systems Laboratories has included the new values for standard DIN Co-efficients from the BS EN 60751 standard and these are named DIN₉₀ in the F250.

4.2.2 General Rules for Data Entry

When the query prompt is displayed, such as "r Lo?", press [ENTER] to clear the display prompt and allow the entry of data. The display will now show a flashing cursor. Use the keypad to type in the numerical data and press [ENTER] again to store the data to memory and to move to the next entry.

A 4 figure number may be entered to represent the PRT serial number. Since a PRT serial number can have a variable number of digits including alphabetic characters, a 4 figure numeric value should be assigned to each PRT to be used with the F250 and a log of these numbers and the PRT serial numbers which they represent should be maintained.

Mistakes in data entry can be corrected in two ways:

- i) If the [ENTER] key has not been pressed after typing in the data, it can be edited by using [←] or [→] keys to move the flashing cursor or digit and typing over the incorrect data. Alternatively, press the [CLEAR] key to clear the whole number, which may then be re-typed.

- ii) To move the decimal point, position the flashing cursor on it using [←] or [→] and press [CLEAR] to remove the decimal point. Now use the [←] or [→] keys to position the flashing cursor over the digit representing the first decimal place. Press the decimal point key to insert the decimal point before the flashing digit. Pressing the decimal point key when the cursor is flashing on the first digit position will enter a 0 (zero) on the display followed by the decimal point, in place of the displayed digit.
- iii) If the data has been entered by pressing the [ENTER] key, the programme will have moved past the data entry point and no correction is possible to previously entered data items. In this case, turn the key switch to [RUN] to exit the CAL mode and abandon all the data just entered. Now turn the key switch to [CAL] to recommence data entry from the start.

However, if a "resistance range too great" error code ("E - 9") is displayed during data entry, press the [ENTER] key to clear the error display and re-enter "r Lo" and "r hi".

4.2.3 Starting the Data Entry Routine - For all 5 Conversion Methods

- i) Insert the key and turn the RUN/CAL switch to the CAL position and the display will indicate "CAL" for approximately two seconds before changing to "ChAn?" This question asks the operator for which PRT Input (A or B) data entry is required. At the same time the LEDs below the A and B switches flash alternately.
- ii) Select the Input required by pressing the appropriate button - for example if data entry is required for PRT Input A, then press [A] once.
- iii) If a switchbox is connected, (in this case to PRT Input A), the next display will ask the question "Ch?-", which is the prompt to enter the switchbox channel number which requires PRT data entry. At this prompt, enter the channel number via the keypad as follows:

Enter the channel number as a two digit number, for example 01, 09 or 13, or a single digit may be entered followed by [ENTER].

For example, if channel number 7 is required, use the key sequence [0][7] or [7][ENTER].

- iv) If no switchbox is connected, or after the switchbox channel is selected, the display will indicate a prompt to review an existing data entry or to enter new data.
- v) The prompt "Edit n" will be displayed, where "n" means "No" and signifies the data review option. The [ENTER] key may now be pressed to review calibration data (see section 4.3 Calibration Data Review) or the "n" changed to "Y" by pressing the [←] or [→] keys, where "Y" means "Yes" and signifies the data entry option. Select "Y" and press [ENTER] in order to enter new calibration data or to edit existing data.
- vi) The prompt "Pr no?" will be displayed to indicate that a 4 figure number representing the PRT serial number should be entered next. Press [ENTER] to display the prompt "no" (number) and the flashing cursor, type in a 4 digit serial number and press [ENTER] to store the data.
- vii) The 5 data entry options will now be displayed sequentially as shown in Figure 4-5. To select the option you require for your PRT, 1, 2, 3, 4 or 5, press the appropriate number on the keypad. For example, if data entry is required in Callendar van Dusen Co-efficients - press [2]. On selecting the data conversion method, the display will momentarily flash confirmation of the operator's choice.

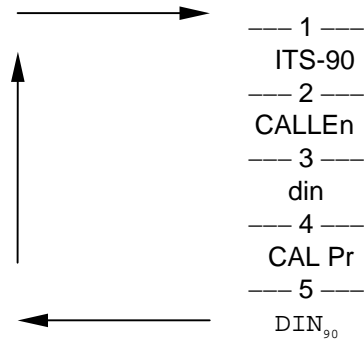

Figure 4-5. Temperature Selection Scrolling Menu

- viii) The F250 will now prompt for data which will be given on the PRT calibration certificate. This will vary according to the choice of resistance to temperature conversion made, but before moving to the appropriate section please note the general rules above on entering and correcting data.
- ix) below are detailed instructions on the required calibration entry method:

ITS-90	- Section 4.2.5
CvD Co-efficients	- Section 4.2.6
DIN (IEC 751)	- Section 4.2.7
CvD temperature/resistance data pairs	- Section 4.2.8
DIN ₉₀ (BS EN 60751)	- Section 4.2.9

4.2.4 Completing the Data Entry

When all data has been entered, the display initially goes blank. As the F250 starts to generate the resistance/temperature conversion table, the actual number of points to be generated will appear on the display and will count down to 0, at which point the process will be complete. The message "StorEd" confirms that the look up table has been created and safely stored in memory. The display will now return to the "CAL", then "ChAn?" prompts with the LEDs for Inputs A and B flashing alternately, unless the RUN/CAL key switch has been returned to the RUN position.

As soon as the count down on the display starts, indicating that the resistance/temperature table is being generated, the RUN/CAL key switch may be returned to the RUN position, since generation of the resistance/temperature table cannot be interrupted by operation of any of the instrument controls, except, of course, the power switch.

Note: If the power is removed from the instrument while a resistance/temperature table is being generated, the conversion table would be unreliable and temperatures derived from it unpredictable. If this happens, the error message "E - 3" will be displayed for this Input/Channel and the calibration data must be re-entered. In addition, in the case of PRT Input A or B, the data validation for the calibration will not have been calculated, since this is generated on completion of conversion table generation. In consequence, the error "E - 7" (data validation error) will be displayed when the F250 is next switched on (see section 4.2.10, item ix for more details on the data validation) and the calibration must be re-entered before using the F250.

If more channels require calibration data to be entered, enter the required PRT Input or switchbox Channel number and follow the procedure described for the calibration method required.

If the display is showing the "ChAn?" prompt and no additional data entry is required, turn the RUN/CAL switch to [RUN]. The screen will flash the message "Abort" alternately with the switch LEDs before returning to RUN mode and displaying the reading in the selected units for the Input/Channel selected. The "Abort" message indicates termination of Calibration Data Entry (CAL) mode and is accompanied by an audible "beep".

4.2.5 ITS-90 Data Entry

On selecting 1, ITS-90, the following data should be entered. Apart from items (ii) and (iii) (see general comments Section 4.2.10), this data should be available from the PRT calibration certificate.

- i) r0.01 ? Resistance in Ohms at +0.01°C (triple point of Water)
- ii) r Lo ? Minimum resistance value for the conversion table
- iii) r hi ? Maximum resistance value for the conversion table
- iv) AP EE Exponent for positive temperature coefficient a.
For example, if $a_p = 5.3 \times 10^{-3}$, enter -3.
- v) AP diG Digits for positive temperature coefficient a. For example,
if $a_p = 5.3 \times 10^{-3}$, enter 5.3 (if $a_p = -5.3 \times 10^{-3}$, enter -5.3)
- vi) bP EE Exponent for positive temperature coefficient b.
Enter the exponent in the same way as for coefficient a.
- vii) bP diG Digits for positive temperature coefficient b.
Enter the digits in the same way as for coefficient a.
- viii) CP EE Exponent for positive temperature coefficient c.
Enter the exponent in the same way as for coefficient a.
- ix) CP diG Digits for positive temperature coefficient c.
Enter the digits in the same way as for coefficient a.
- x) DP EE Exponent for positive temperature coefficient d.
Enter the exponent in the same way as for coefficient a.
- xi) DP diG Digits for positive temperature coefficient d.
Enter the digits in the same way as for coefficient a.
- xii) An EE Exponent for negative temperature coefficient a.
Enter the exponent in the same way as for positive coefficient a.
- xiii) An diG Digits for negative temperature coefficient a.
Enter the digits in the same way as for positive coefficient a.
- xiv) bn EE Exponent for negative temperature coefficient b.
Enter the exponent in the same way as for coefficient a.
- xv) bn diG Digits for negative temperature coefficient b.
Enter the digits in the same way as for coefficient a.
- xvi) 660? The ratio $W(T_{90})$ { $W(T_{90}) = R(T_{90})/R(273.16K)$ } at the freezing point of Aluminium. This value is required only when a dp (d positive) coefficient is entered. Enter the ratio $W(T_{90})$ and press the [ENTER] key to complete the data entry.

Where fewer than four positive and two negative Co-efficients are available, zero may be entered for the Co-efficients not available: or simply press the [ENTER] key in response to the prompt.

Example:

Enter an ITS-90 PRT calibration with $R_{0.01} = 100.05 \Omega$, a positive $= 2.458 \times 10^{-4}$, minimum resistance of 79Ω and maximum resistance of 198Ω .

<u>Display Prompt</u>	<u>Value</u>	<u>Key Input</u>
-----------------------	--------------	------------------

"r0.01 ?"	100.05	[ENTER][1][0][0][.][0][5][ENTER]
"r Lo ?"	79	[ENTER][7][9][ENTER]
"r hi ?"	198	[ENTER][1][9][8][ENTER]
"AP EE"	-4	[ENTER][-][4][ENTER]
"AP diG"	2.458	[ENTER][2][.][4][5][8][ENTER]

All Co-efficients have to be input in European format.

The table below cross references US to European format. In order to relate Co-efficients from European calibrations with the US notation, it is important to know the 'sub-range' of calibration which is usually found on the calibration certificate.

Range	United States	Europe
83.8058K to 273.16K	a4 and b4	a and b (negative)
273.15K to 961.78°C	a6, b6, c6 and d	a,b,c & d (positive)
273.15K to 660.323°C	a7, b7, and c7	a, b and c (positive)
273.15K to 419.527°C	a8 and b8	a and b (positive)
273.15K to 231.928°C	a9 and b9	a and b (positive)
273.15K to 156.59865°C	a10	a (positive)
273.15K to 29.7646°C	a11	a (positive)
234.3156K to 29.7646°C	a5 and b5	a and b (positive or negative)

ITS-90 Co-efficients US-European conversion chart

4.2.6 Callendar van Dusen (using Co-efficients)

On selecting 2, Callendar van Dusen Co-efficients, the following data should be entered. Apart from items (ii) and (iii) (see general comments Section 4.2.10), these data should be available from the PRT calibration certificate.

- i) r0 ? PRT resistance at 0°C
- ii) r Lo ? Minimum resistance value for the conversion table
- iii) r hi ? Maximum resistance value for the conversion table
- iv) AP EE Exponent for temperature co-efficient A.
For example, if $A = 5.3 \times 10^{-3}$, enter -3.

- v) AP diG Digits for temperature co-efficient A. For example, if $A = 5.3 \times 10^{-3}$, enter 5.3 (if $A = - 5.3 \times 10^{-3}$, enter -5.3)
- vi) bP EE Exponent for temperature co-efficient B. Enter the exponent in the same way as for coefficient A.
- vii) bP diG Digits for temperature coefficient B. Enter the digits in the same way as for co-efficient A.
- viii) CP EE Exponent for temperature co-efficient C. Enter the exponent in the same way as for co-efficient A.
- ix) CP diG Digits for temperature co-efficient C. Enter the digits in the same way as for co-efficient A.

Example:

Enter a Callendar van Dusen PRT calibration with $R_0 = 100.05 \Omega$, $A = 3.908 \times 10^{-3}$, $B = - 5.802 \times 10^{-7}$, $C = - 4.2735 \times 10^{-12}$, a minimum resistance of 79Ω and a maximum resistance of 198Ω .

<u>Display Prompt</u>	<u>Value</u>	<u>Key Input</u>
"r0 ?"	100.005	[ENTER][1][0][0][.][0][0][5][ENTER]
"r Lo ?"	79	[ENTER][7][9][ENTER]
"r hi ?"	198	[ENTER][1][9][8][ENTER]
"AP EE"	-3	[ENTER][-][3][ENTER]
"AP diG"	3.908	[ENTER][3][.][9][0][8][ENTER]
"bP EE"	-7	[ENTER][-][7][ENTER]
"bP diG"	-5.802	[ENTER][-][5][.][8][0][2][ENTER]
"CP EE"	-12	[ENTER][-][1][2][ENTER]
"CP diG"	-4.2735	[ENTER][-][4][.][2][7][3][5][ENTER]

Where values for CvD Co-efficients are not provided on the calibration certificate, for example if no calibration is carried out below 0°C and no value for C is given, the value 0 (zero) should be entered, or simply press the [ENTER] key without typing in any digits in response to the prompts for exponent and digits for co-efficient C.

If the Co-efficients entered are as below:

$$A = 3.90802 \times 10^{-3}$$

$$B = - 5.802 \times 10^{-7}$$

$$C = - 4.2735 \times 10^{-12}$$

$$R_0 = 100 \text{ Ohms}$$

then the DIN standard, as in 4.2.7 has been entered.

4.2.7 DIN Standard (IEC 751)

Entering 3 from the data entry menu selects the DIN Standard (IEC751/DIN43760/BS1904). The only data required to be entered is r Lo and r hi (minimum and maximum values for the resistance range). The DIN Co-efficients, which have defined values for the Callendar van Dusen equation, are stored in memory. r Lo and r hi determine the resistance range over which the resistance/temperature look up table will be created.

The DIN Co-efficients are as follows:

$$A = 3.90802 \times 10^{-3}$$

$$B = - 5.802 \times 10^{-7}$$

$$C = - 4.2735 \times 10^{-12}$$

$$R_0 = 100 \text{ Ohms}$$

Example:

Enter a DIN PRT calibration with a minimum resistance of 65 Ω and a maximum resistance of 196 Ω .

<u>Display Prompt</u>	<u>Value</u>	<u>Key Input</u>
"r Lo ?"	65	[ENTER][6][5] [ENTER]
"r hi ?"	196	[ENTER][1][9][6] [ENTER]

4.2.8 Callendar van Dusen - (using data pairs)

On selecting 4, Callendar van Dusen resistance/temperature data pair entry is selected. The data pairs are used to calculate the co-efficients for the CvD equations, which in turn are used to create the resistance/ temperature conversion table.

Data should be entered as follows. Apart from items (i) and (ii) (see general comments Section 4.2.10), these data should be available from the PRT calibration certificate. Prompts shown in parentheses are those displayed when Fahrenheit temperature entry is selected.

- | | | |
|-------|-------------------|--|
| i) | r Lo ? | Minimum resistance value for the conversion table |
| ii) | r hi ? | Maximum resistance value for the conversion table |
| iii) | C or F | Celsius or Fahrenheit |
| iv) | t0° ? (t32° ?) | Temperature nearest to 0°C |
| v) | r t0°? (r t32° ?) | Resistance at temperature nearest 0°C |
| vi) | t 100°? (t212° ?) | Temperature nearest 100°C |
| vii) | r t100 (r t212 ?) | Resistance at temperature nearest 100°C |
| viii) | t° P ? | Another <u>positive</u> temperature (> 32°F) |
| ix) | r t°P? | Resistance at <u>positive</u> temperature (Resistance at > 32°F) |
| x) | t° n ? | A <u>negative</u> temperature (< 32°F) |
| xi) | r t°n? | Resistance at <u>negative</u> temperature (Resistance at < 32°F) |

Example:

<u>Display Prompt</u>	<u>Value</u>	<u>Key Input</u>
"r Lo ?"	80	[ENTER][8][0][ENTER]
"r hi ?"	198	[ENTER][1][9][8] [ENTER]
"t0 ?"	0.051	[ENTER][0][.] [0][5][1][ENTER]
"r t0?"	100.020	[ENTER][1][0][0][.] [0][2][ENTER]
"t 100°?"	99.993	[ENTER][9][9][.] [9][9][3][ENTER]
"r t100"	138.498	[ENTER][1][3][8][.] [4][9][8][ENTER]
"t° P?"	250.023	[ENTER][2][5][0][.] [0][2][3][ENTER]
"r t°P?"	194.006	[ENTER][1][9][4][.] [0][0][6][ENTER]
"t° n ?"	-40.007	[ENTER][-][4][0][.] [0][0][7][ENTER]
"r t°n?"	84.263	[ENTER][8][4][.] [2][6][3][ENTER]

Note: It is important to ensure that appropriate values for the resistance/temperature data pairs are entered. Failure to do this can cause unpredictable results when calculating the resistance/temperature conversion table. In this event, switch the CAL/RUN key switch back to RUN and switch off the power switch on the F250. Switch the power on again, switch the CAL/RUN key switch to CAL and recommence the data calibration entry.

4.2.9 DIN₉₀ (BS EN 60751)

Entering 5 from the data entry menu selects the DIN₉₀ standard. The advantage of it is that it removes the temperature conversion errors associated with the old DIN standard which is based on the earlier and obsolete International Practical Temperature Scale IPTS68.

The Co-efficients for DIN₉₀ are as follows:

$$A_{90} = 3.9083 \times 10^{-3}$$

$$B_{90} = - 5.775 \times 10^{-7}$$

$$C_{90} = - 4.183 \times 10^{-12}$$

$$R_0 = 100 \text{ Ohms}$$

The only data required to be entered is r Lo and r hi. The Co-efficients, as defined above for the Callendar van Dusen equation, are stored in memory. r Lo and r hi determine the resistance range over which the resistance/temperature look up table will be created.

Example:

Enter a DIN₉₀ PRT calibration with a minimum resistance of 65 Ω and a maximum resistance of 196 Ω.

<u>Display Prompt</u>	<u>Value</u>	<u>Key Input</u>
"r Lo ?"	65	[ENTER][6][5][ENTER]
"r hi ?"	196	[ENTER][1][9][6][ENTER]

4.2.10 General Comments

- i) r Lo :- This is the minimum resistance for F250 to generate a temperature/resistance conversion table. This resistance should not be significantly lower than the range over which the PRT has been calibrated and for which Co-efficients have been provided. The F250 can generate a conversion table over a wider range, but temperatures derived from extrapolation beyond the calibration minimum point will not be traceable to International Standards. It is recommended

that a value of nominally 1 Ω or 1 ohm lower than the minimum calibration value is entered to avoid an "out of range" (E-2) error message.

- ii) r_{hi} :- This is the maximum resistance for F250 to generate a temperature/resistance conversion table. This resistance should not be significantly higher than the range over which the PRT has been calibrated and for which Co-efficients have been provided. The extrapolation rule above applies. It is recommended that a value of nominally 1 Ω or 1 ohm higher than the maximum calibration value is entered to avoid an "out of range" (E-2) error message.
- iii) The resistance range of the conversion table generated (r_{Lo} to r_{hi}) must be no greater than 395 Ω , or an error ("E - 9") will occur (see Error Codes, section 10). Should this error code be displayed during data entry, press the [ENTER] key to clear the error display and re-enter r_{Lo} and r_{hi} . This range will almost certainly be greater than that required for the majority of PRT and temperature measurement applications.
- iv) The smaller the resistance range, the shorter will be the calculation time required to generate a resistance/temperature conversion table.
- v) Where values for Co-efficients are not provided in ITS-90 or CvD coefficient entry, for example if no calibration is carried out below 0°C and consequently no negative temperature coefficient values given, the value 0 (zero) should be entered, or a null entry made by pressing the [ENTER] key without entering a value.
- vi) Once the conversion table "number countdown" has started, the RUN/CAL key switch may be turned back to "RUN". Generation of the resistance/temperature conversion table will continue until complete, the message "StorEd" will be displayed and the F250 will start to measure temperature immediately without prompting for further data entry.
- vii) If data is to be entered for more than one PRT Input or Channel, a different resistance/temperature conversion method may be chosen for each channel.
- viii) An "E - 3" error being displayed indicates no calibration for the Input or Channel being displayed.
- ix) An "E - 7" error being displayed indicates a data validation error, that is an error has occurred which has invalidated the calibration for PRT Input A or B. The latter occurrence is highly unlikely, but this indication is provided so that the operator may at all times have confidence in the integrity of the PRT probe calibration entered (see section 10, Error Codes).

The calibration data validation value is calculated on completion of temperature/resistance conversion table generation. The validation is also generated when a calibration data entry is canceled by switching the RUN/CAL key switch back to RUN, although in this case a "no calibration" code ("E - 3") will be displayed.

The calibration data is checked and validated against the stored validation value every time the F250 power is switched on or a CLEAR command issued via the interface.

4.3 Calibration Data Review (CAL) Operation

4.3.1 General Rules for Data Review

The key operated switch on the F250 must be set to **CAL** for all functions in the sections below.

The F250 allows for 5 alternative mathematical methods of converting resistance to temperature. The choice will depend on the type of PRT and its calibration, see section 7, Sensor Information and section 8, International Temperature Scale.

- i) ITS-90 Co-efficients:- intended for PRTs with high "alpha" values of 0.003926 to 0.003928, generally laboratory type PRTs.
- ii) Callendar van Dusen Co-efficients:- for industrial or low "alpha" PRTs of 0.00385.
- iii) DIN:- used for uncalibrated industrial PRTs with 0.00385 "alpha" value, to provide a conversion of resistance to temperature in accordance with the old IEC751 standard.
- iv) Callendar van Dusen data pairs:- as (ii), but data is provided in temperature/resistance data pairs.
- v) DIN₉₀:- As (iii) but using Co-efficients in accordance with the BS EN 60751 standard. The Co-efficients for DIN₉₀ are as follows:

$$A_{90} = 3.9083 \times 10^{-3}$$

$$B_{90} = - 5.775 \times 10^{-7}$$

$$C_{90} = - 4.183 \times 10^{-12}$$

$$R_0 = 100 \text{ Ohms}$$

The "alpha" value for DIN₉₀ PRTs is 0.00385055°C⁻¹.

See also General Comments in section 4.3.8.

4.3.2 Starting the Data Review Routine - For all 5 Conversion Methods

- i) Insert the key and turn the RUN/CAL switch to the CAL position and the display will indicate "CAL" for approximately two seconds before changing to "ChAn?" This question asks the operator for which PRT Input (A or B) data review is required. At the same time the LEDs below the A and B switches flash alternately.
- ii) Select the PRT Input required by pressing the appropriate button - for example if data review is required for PRT Input A, then press [A] once.
- iii) If a switchbox is connected, (in this case to PRT Input A), the next display will ask the question "Ch?-", which is the prompt for the switchbox channel number to be entered for which PRT data review is required. At this prompt, enter the channel number via the keypad as follows:

Enter the channel number as a two digit number, for example 01, 09 or 13,
or as a single digit followed by [ENTER].

For example, if channel number 7 is required, use the key sequence [0][7] or [7][ENTER].
- iv) If no switchbox is connected, or after the switchbox channel is selected, the display will indicate a prompt to review an existing data entry or to enter new data.
- v) The prompt "Edit n" will be displayed, where "n" means "No" and signifies the data review option. (At this point the [←] or [→] keys may be pressed to change the prompt to "Edit Y" in order to enter new calibration data: see section 4.2 Calibration Data Entry). Now press the [ENTER] key with the prompt showing "Edit n" to review existing calibration data.
- vi) The message "Pr no" will be displayed to indicate the PRT serial number. Press [ENTER] to display a four digit number representing the PRT serial number, then press [ENTER] again to continue.

- vii) The type of calibration method will be displayed with the message "CALtYP". Press [ENTER] to display the calibration method, then press [ENTER] again to display the calibration data. The calibration data for each calibration method is listed in the following sections:

ITS-90	- Section 4.3.3
CvD Co-efficients	- Section 4.3.4
DIN (IEC 751)	- Section 4.3.5
CvD temperature/resistance data pairs	- Section 4.3.6
DIN ₉₀ (BS EN 60751)	- Section 4.3.7

4.3.3 ITS-90 Data Review

ITS-90 coefficient data may be reviewed as follows:

- i) r0.01 Resistance in Ohms at +0.01°C (triple point of Water)
- ii) r Lo Minimum resistance value for the conversion table
- iii) r hi Maximum resistance value for the conversion table
- iv) AP EE Exponent for positive temperature coefficient a.
For example, if $a_p = 5.3 \times 10^{-3}$, the value displayed will be -3.
- v) AP diG Digits for positive temperature coefficient a. For example,
if $a_p = 5.3 \times 10^{-3}$, the value displayed will be 5.3
- vi) bP EE Exponent for positive temperature coefficient b.
- vii) bP diG Digits for positive temperature coefficient b.
- viii) CP EE Exponent for positive temperature coefficient c.
- ix) CP diG Digits for positive temperature coefficient c.
- x) DP EE Exponent for positive temperature coefficient d.
- xi) DP diG Digits for positive temperature coefficient d.
- xii) An EE Exponent for negative temperature coefficient a.
- xiii) An diG Digits for negative temperature coefficient a.
- xiv) bn EE Exponent for negative temperature coefficient b.
- xv) bn diG Digits for negative temperature coefficient b.
- xvi) 660? The ratio $W(T_{90}) \{ W(T_{90}) = R(T_{90})/R(273.16K) \}$ at the freezing point of Aluminium. This value is required only when a dp (d positive) coefficient has been entered.

Where fewer than four positive and two negative Co-efficients are available, zero will be displayed for the Co-efficients not available.

Following review, the display will return to the "CAL", then "ChAn?" prompts with the LEDs for Inputs A and B flashing alternately, unless the RUN/CAL key switch has been returned to the RUN position.

If calibration data is to be reviewed on other PRT Inputs/Channels, enter the PRT Input (and Channel, if a switchbox is attached) and press the [ENTER] key to display each item of calibration data.

If the display is showing the "ChAn?" prompt and no additional data review is required, turn the RUN/CAL switch to [RUN]. The screen will flash the message "Abort" alternately with the switch LEDs before returning to RUN mode and displaying the reading in the selected units for the PRT Input/Channel

selected. The "Abort" message indicates termination of Calibration Data Review (CAL) mode and is accompanied by an audible "beep".

4.3.4 Callendar van Dusen Data Review (using Co-efficients)

Callendar van Dusen coefficient data may be reviewed as follows:

- i) r0 PRT resistance at 0°C
- ii) r Lo Minimum resistance value for the conversion table
- iii) r hi Maximum resistance value for the conversion table
- iv) AP EE Exponent for temperature coefficient A.
For example, if $A = 5.3 \times 10^{-3}$, the value -3 will be displayed.
- v) AP diG Digits for temperature coefficient a. For example,
if $A = 5.3 \times 10^{-3}$, the value 5.3 will be displayed
- vi) bP EE Exponent for temperature coefficient B.
- vii) bP diG Digits for temperature coefficient B.
- viii) CP EE Exponent for temperature coefficient C.
- ix) CP diG Digits for temperature coefficient C.

Where values for CvD Co-efficients are not available, the value 0 (zero) will be displayed.

If the Co-efficients entered are as below:

$$A = 3.90802 \times 10^{-3}$$

$$B = - 5.802 \times 10^{-7}$$

$$C = - 4.2735 \times 10^{-12}$$

$$R_0 = 100 \text{ Ohms}$$

then the DIN standard, as in 4.3.5, has been entered.

Following review, the display will return to the "CAL", then "ChAn?" prompts with the LEDs for PRT Inputs A and B flashing alternately, unless the RUN/CAL key switch has been returned to the RUN position.

If calibration data is to be reviewed on other PRT Inputs/Channels, enter the PRT Input (and Channel, if a switchbox is attached) and press the [ENTER] key to display each item of calibration data.

If the display is showing the "ChAn?" prompt and no additional data review is required, turn the RUN/CAL switch to [RUN]. The screen will flash the message "Abort" alternately with the switch LEDs before returning to RUN mode and displaying the reading in the selected units for the PRT Input/Channel selected. The "Abort" message indicates termination of Calibration Data Review (CAL) mode and is accompanied by an audible "beep".

4.3.5 DIN Standard Data Review

DIN Standard signifies IEC751/DIN43760/BS1904. The only data which will be displayed are r_{Lo} and r_{hi} . The DIN Co-efficients, which have defined values for the Callendar van Dusen equation, are stored in memory. r_{Lo} and r_{hi} define the resistance range over which the resistance/temperature conversion table has been created.

The DIN Co-efficients are as follows:

$$A = 3.90802 \times 10^{-3}$$

$$B = - 5.802 \times 10^{-7}$$

$$C = - 4.2735 \times 10^{-12}$$

$$R_0 = 100 \text{ Ohms.}$$

4.3.6 Callendar van Dusen Data Review (using data pairs)

Callendar van Dusen temperature/resistance data may be reviewed as follows:

- i) r_{Lo} Minimum resistance value for the conversion table
- ii) r_{hi} Maximum resistance value for the conversion table
- iii) t_1 Temperature nearest to 0°C (32°F)
- iv) r_{t_1} Resistance at temperature nearest 0°C (Resistance at 32°F)
- v) t_2 Temperature nearest 100°C (212°F)
- vi) r_{t_2} Resistance at temperature nearest 100°C (Resistance at 212°F)
- vii) t_3 Another positive temperature (> 32°F)
- viii) r_{t_3} Resistance at positive temperature (Resistance at > 32°F)
- ix) t_4 A negative temperature (< 32°F)
- x) r_{t_4} Resistance at negative temperature (Resistance at < 32°F)

Where values for CvD data pairs are not available, the value 0 (zero) will be displayed.

Following review, the display will return to the "CAL", then "ChAn?" prompts with the LEDs for PRT Inputs A and B flashing alternately, unless the RUN/CAL key switch has been returned to the RUN position.

If calibration data is to be reviewed on other PRT Inputs/Channels, enter the PRT Input (and Channel, if a switchbox is attached) and press the [ENTER] key to display each item of calibration data.

If the display is showing the "ChAn?" prompt and no additional data review is required, turn the RUN/CAL switch to [RUN]. The screen will flash the message "Abort" alternately with the switch LEDs before returning to RUN mode and displaying the reading in the selected units for the PRT Input/Channel selected. The "Abort" message indicates termination of Calibration Data Review (CAL) mode and is accompanied by an audible "beep".

4.3.7 DIN₉₀ Data Review (BS EN 60751)

The only data which will be displayed are r_{Lo} and r_{hi}, which define the resistance range over which the resistance/ temperature conversion table has been created.

The DIN₉₀ Co-efficients, which have defined values for the Callendar van Dusen equation, are stored in memory and are defined as follows:

$$A_{90} = 3.9083 \times 10^{-3}$$

$$B_{90} = - 5.775 \times 10^{-7}$$

$$C_{90} = - 4.183 \times 10^{-12}$$

$$R_0 = 100 \text{ Ohms.}$$

4.3.8 General Comments

- i) r_{Lo} :- This is the minimum resistance of the F250 temperature/resistance conversion table. The resistance value displayed will be the integer of the value entered.
- ii) r_{hi} :- This is the maximum resistance for F250 to generate a temperature/resistance conversion table. The resistance value displayed will be the integer of the value entered.
- iii) The maximum resistance range (r_{Lo} to r_{hi}) can be no greater than 395Ω. This range will almost certainly be greater than that required for the majority of PRTs and temperature measurement applications.
- iv) Where values for Co-efficients are not provided in ITS-90 or CvD coefficient entry, for example if no calibration is carried out below 0°C and consequently no negative temperature coefficient values have been entered, the value 0 (zero) will be displayed.
- v) Calibration data review may be canceled at any time by turning the RUN/CAL key switch back to "RUN". The screen will flash the message "Abort" alternately with the switch LEDs before returning to RUN mode and displaying the reading in the selected units for the Input/Channel selected.
- vi) If data is to be reviewed for more than one Input or Channel, following display of the last calibration entry, the display will automatically return to the "CAL", then "ChAn?" prompts with the LEDs for PRT Inputs A and B flashing alternately. Enter PRT Input (A or B) and Channel number for the next calibration entry to be reviewed and continue as described above (Starting the Data Review Routine, section 4.3.2)
- vii) An "E - 3" error being displayed indicates no calibration for the PRT Input or Channel being displayed.
- viii) An "E - 7" error being displayed indicates a data validation error, that is an error has occurred which has invalidated the calibration for PRT Input A or B. The latter occurrence is highly unlikely, but this indication is provided so that the operator may at all times have confidence in the integrity of the PRT calibration entered (see section 10, Error Codes and section 4.2.10, item ix).

5. Working with the SB250-8 or SB250-16 switchbox

The SB250-8 (8 channel) and SB250-16 (16 channel) switchboxes, have been specially designed to allow PRT Inputs A and B on the F250 to be expanded to measure up to 16 channels each, with no degradation in instrument performance. Both direct (absolute) and differential measurements can be made when using the SB250-8 or SB250-16 switchboxes.

5.1 Connection and Control

PRT connection may be via the front panel or the back panel. Each channel has high isolation, low resistance, 5-pin relays giving full 4 terminal measurement plus ground connection. Visual indication is provided of the switchbox address by an LED on the right hand side of the front panel of the switchbox. Channel selection is indicated by an LED above the active 5 pin DIN connector on the front panel. Up to two SB250-8 or SB250-16 switchboxes can be operated directly from the keypad of the F250 or remotely using the F250 communications interface. When operated via RS232 or IEEE interface, a Channel can be selected and temperature read in any of the units selectable on the F250 ($^{\circ}\text{C}$, $^{\circ}\text{F}$, K and Ω).

5.1.1 Switchbox Address

Before a switchbox can be used on PRT Input A or B, the switchbox address (A or B) must be set. When two switchboxes are in use, one must be set for use with PRT Input A and the other for use with PRT Input 'B'.

To set the switchbox address disconnect the instrument from the power supply and remove the instrument top cover. The top cover is retained by 4 screws. At the upper right of the front printed circuit board (on which the front panel DIN connectors are mounted), on the inner side of the circuit board is a two position toggle switch accessible from above. Looking at the top of the switchbox, when the switch toggle points to the right hand side (towards the outer edge) of the switchbox, address A is selected, for switchbox connection to F250 PRT Input A. When the switch toggle points to the left hand side (towards the center) of the switchbox, address B is selected, for switchbox connection to F250 PRT Input B. After selecting the required switchbox address, refit the top cover and secure the 4 mounting screws.

When in use, one of two LEDs on the right hand side of the front panel of the switchbox will be illuminated to indicate the F250 PRT Input to which the switchbox is connected (the switchbox address).

5.1.2 Connections

Connectors 0 - 15 (or 0 - 7, for the 8 channel SB250-8) allow the PRTs to be connected at the front of the switchbox, or at the rear if the screw terminals on the back panel are used. Each parallel connector pair (shown in Figure 2-2 for the F250 instrument) represents one channel, with the LEDs on the front panel of each switchbox indicating which channel is selected. The switchbox channel LEDs are also used to indicate the selected channel when PRT calibration data is being entered.

Note: Each front panel PRT input is connected in parallel to a 5 pin terminal socket on the rear panel for use with 4 wire PRTs without DIN plugs. Therefore each channel input must have a PRT connected only to the front socket OR to the back socket, NOT to both.

Power lines, control lines and data lines to and from the switchbox are all carried on the ribbon cable between the F250 and the SB250-8 or SB250-16. The ribbon cable is connected between the "Control Input" port on the SB250-8 or SB250-16 and the "Expansion Port" on the F250. The 4 wire measurement signals plus ground are carried separately from the "Output" screw terminal connector on the rear of the SB250-8 or SB250-16 to the appropriate A or B PRT Input on the rear of the F250.

5.1.3 Power On

After connecting the control cable (the ribbon cable) and the PRT connectors of the SB250-8 or SB250-16 to the required PRT Input on the F250, as described above, switch the power on and the display test will proceed as described in Section 3.1.2. In addition, all the switchbox channel LEDs will be illuminated in sequence to indicate that the switchbox channels can be selected. Ensure that the address switch is set for the required F250 PRT Input (A or B).

Connect a PRT to channel 0, either via the front panel connector or the back panel connector, **but not both**. With no calibration data installed, the F250 will be able to display resistance only, so set units to Ω (Ohms). Using the A or B push buttons on the F250, select the PRT Input with the switchbox attached. The prompt for the channel number will appear, "Ch?-". Enter the channel number [0] and press [ENTER]. Note when the channel number is two digits, it is accepted automatically and pressing the [ENTER] key is not required. A channel number less than 10 can also be entered as a two digit number by adding a leading zero, for example 01 for channel number 1.

5.2 PRT Data Entry

When SB250-8 or SB250-16 switchboxes are used, PRT data is held in non-volatile memory (EEPROM - Electrically Erasable Programmable Read Only Memory) within the switchbox itself, although data entry is performed in the same way as when using the F250 alone and is as described in Section 4.2. The 5 alternative methods of data entry, ITS-90, Callendar van Dusen Co-efficients, DIN, Callendar van Dusen data pairs and DIN₉₀, are available for data entry for PRTs attached to the switchbox, in the same way as when using the F250 without switchboxes.

Follow the data entry procedure in Section 4.2, taking particular note of the requirements when a switchbox is connected. Once data entry has started, the appropriate SB250-8 or SB250-16 channel will be selected to enable the data to be stored in the section of the EEPROM reserved for that channel.

5.3 PRT Data Review

When SB250-8 or SB250-16 switchboxes are used, data review is performed in the same way as when using the F250 alone and is as described in Section 4.3.

Follow the data review procedure in Section 4.3, taking particular note of the requirements when a switchbox is connected (enter the channel number in the correct form).

6. Calibration

6.1 F250

The AC bridge technology of the F250 is inherently very linear, however this is improved further by calibration, or linearisation, during final test. After manufacturing each F250 is measured against 4 precision resistors which are traceable to International Standards. This calibration information is then stored in a system Rom within the instrument, providing a corrected linearity to better than ± 4 milli-ohms (equivalent to ± 10 mK with a Pt100 PRT). The long term stability of AC bridge technology makes this method of linearisation valid over long periods of time and it will not normally be necessary to re-linearize the F250 on a regular basis. Experience has shown that other instruments using this method need very little correction after several years of use.

Whilst PRT calibration data entry may be entered by the user, instrument calibration, or linearisation, must be carried out at the factory.

6.2 PRTs

For the most accurate temperature measurement, the F250 will use stored calibration data for each PRT that it operates. For general industrial work, the IEC751/DIN43760 or the BS EN 60751 standard may be used (see section 12.1 for measurement accuracy of F250 + PRT or F250 + uncalibrated DIN PRT). A range of PRTs are available in low and high alpha wire, although the former is normal for industrial applications. See Sections 7 and 8 on Sensors and on the International Temperature Scales.

The relationship between temperature and resistance varies depending on several factors including the alpha value and the PRT calibration. Consequently more than one equation is required for resistance to temperature conversion. Calibration data for the PRTs can take the form of either resistance/temperature data pairs or Co-efficients. The F250 gives the user 5 alternative data entry formats. See also section 7, Sensor Information; section 8, International Temperature Scale; section 4.2, Calibration Data Entry; and section 4.3, Calibration Data Review for more detailed information on PRTs and calibration data entry and review.

7. Sensor Information

The F250 will operate with a range of 4-wire 100 Ohm PRT, often referred to as Pt100.

Higher specification 25 Ohm and high temperature 10 Ohm PRTs also may be used.

However, the best performance will be achieved only where good quality PRTs are used from reputable, proven sources. As with any measured parameter, the performance of a measurement system depends upon its stability and repeatability. Low quality PRTs are likely to reduce system performance.

Automatic Systems Laboratories provides a range of proven PRTs especially for use with the F250, as well as offering a service to provide customized PRTs to meet individual customers' requirements.

7.1 High "alpha" PRTs

The best possible system accuracy is achieved using high "alpha" (α) PRTs, or more correctly, PRTs using high α (high purity) platinum wire.

7.2 Low "alpha" PRTs

Low α PRTs contain a higher level of impurities in the platinum resistance wire used, this affects the resistance value at a given temperature (the temperature coefficient). As impurities already exist in the platinum resistance wire, additional contamination has a reduced effect and hence low α PRTs are the best for industrial applications. To ensure a robust PRT, the detector within the PRT is constrained within other materials which can also be the source of contamination at elevated temperatures. The PRTs supplied by Automatic Systems Laboratories have been optimized for the temperature ranges for which they are specified and, when calibrated, are temperature cycled to enhance stability in use.

PRTs which are used outside their design and/or calibration temperature range, especially at higher temperatures, risk alteration to their calibration either by induced thermal stresses or by contamination.

8. International Temperature Scale

The purpose of the International Temperature Scale is to define procedures by which certain specified practical PRTs of the required quality can be calibrated in such a way that the values of temperature obtained from them can be precise and reproducible: and at the same time matching the corresponding thermodynamic values as closely as current technology permits.

Since 1968 when the IPTS68 was adopted, there have been significant advances in the techniques employed in establishing temperature standards and in the measurement of thermodynamic temperature. The International Temperature Scale of 1990 (ITS-90) gives practical effect to these improvements. Particular features are:

- i) ITS-90 specifies the use of the PRT up to the freezing point of silver, 961.78°C. The platinum 10% rhodium/platinum thermocouple is no longer specified for use in the scale, though it and other noble metal thermocouples will continue to be used as secondary standards.
- ii) New, more precise, fixed points have been introduced and mathematical procedures for calculating resistance/temperature equivalents have been revised so as to reduce the 'non-uniqueness' of the scale: that is, to reduce the differences which occur between different, identically calibrated PRTs. In particular, the calibration of a PRT can no longer be extrapolated beyond the freezing point of zinc, 419.527°C, but requires a measurement at the freezing point of aluminium, 660.323°C.
- iii) Alternative definitions are permitted in certain sub-ranges, so that the calibration of a PRT can be terminated at almost any fixed point. This provision allows primary calibrations to be carried out with suitable PRTs over reduced ranges, and will be of special importance to metrology standards departments which need to make precise measurements at ambient temperatures.
- iv) The part of the ITS-90 scale which may be measured by PRTs extends from 83.8058 K (-189.3442°C) to 961.78°C. The F250 is specified to measure temperature over the range -200°C to +962°C. The actual range of temperatures which may be measured depends on the type and range of the PRT in use.

The ITS-90 scale has much improved continuity, precision and reproducibility compared with IPTS68. The implementation of the ITS-90 scale according to its definition calls for significant changes in equipment and procedure compared with IPTS68, but lower uncertainties of calibration are achievable in all parts of the range. However, the instruments and equipment needed to implement the ITS-90 scale in calibration laboratories will be substantially the same.

9. Communications / Output Options

An optional communications interface/analogue output board can be installed in the F250, and supplied with any combination of the following three interfaces:

- RS232C serial digital communications interface
- IEEE488 parallel digital communications interface
- DC Analogue Output

The board itself is normally factory installed but can be retro-fitted by a competent technician. The interface board has 3 separate areas, each devoted to one of the options indicated above. It may be installed in the F250 in one of two orientations depending on which digital interface is used. If an analogue output is included, an output socket is installed at both ends of the board to enable access no matter which digital interface is being used.

When power is switched on to the F250, the display will show "rS232" if an RS232C interface is installed, if no interface board is installed, or if an IEEE interface is installed with the IEEE address switch set to 0 (zero). If IEEE488 is installed, the start up display will show "IEEE n" (with the exception noted above), where n is the number from 1 to 7 for the IEEE controller address in the F250.



WARNING:

SWITCH OFF THE INSTRUMENT AND REMOVE THE POWER SUPPLY CABLE BEFORE REMOVING THE INSTRUMENT CASE.

9.1 Fitting the Interface

- i) Remove the 4 screws holding the top half of the instrument case and lift off vertically, taking care not to stretch or break the ground connection to the case cover (green/yellow wire).
- ii) The interface board may be installed with RS232C interface, IEEE488 interface, RS232C interface and analogue output, or IEEE488 interface and analogue output. Select the interface/output required and hold the board over the F250 so that the connector for this output is at the rear of the instrument.
- iii) The interface board is held into the F250 between two metal spacers at the front end and two screws into captive nuts on the back panel. When fitting the board ensure that the nylon insulating washers are fitted. Connect the ribbon cable (main interface connector is 34 way, analogue connector is 10 way) on the board to its connector on the F250 mother board, then gently lower the interface and secure it in place.
- iv) Replace the instrument top case and secure the 4 mounting screws.

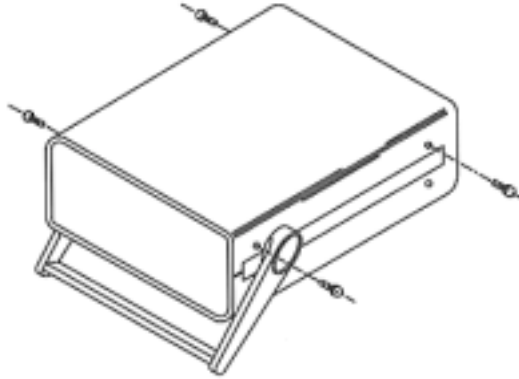

Figure 9-1 Fitting an Interface PCB

9.2 RS232C Interface

RS232C communication is via a 9-pin socket, D-type connector on the back panel as shown in figure 9-2.

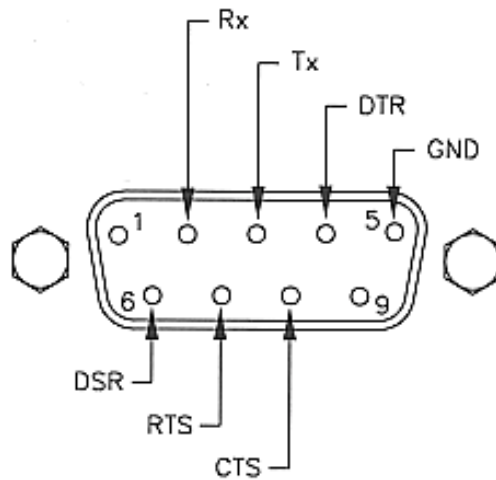

Figure 9-2. RS232 Connector

9.2.1 Pin Connections

Computer		Function	F250
25-Pin Connector	9-Pin Connector		9-Pin Connector
3	2	Rx	2
2	3	Tx	3
20	4	DTR	4
7	5	GND	5
6	6	DSR	6
4	7	RTS	7
5	8	CTS	8

9.2.2 RS232C Settings

As supplied by the factory, unless requested otherwise, the RS232C interface is configured as follows:

- 19,200 Baud
- 8 Character bits
- No Parity
- 2 Stop Bits

These parameters can be changed using the following procedure:

- i) Switch off the power supply and remove the power cable.
- ii) Remove the 4 screws holding the top half of the instrument case.
- iii) Lift off the top half of the case and locate the 8-way DIP (Dual In-line Pin) switch close to the RS232 connector at the rear of the board. The DIP switch has a row of small lever switches on one side: the one nearest the rear of the instrument is number 1, the one nearest the front is number 8. The numbers are marked below the switch levers.

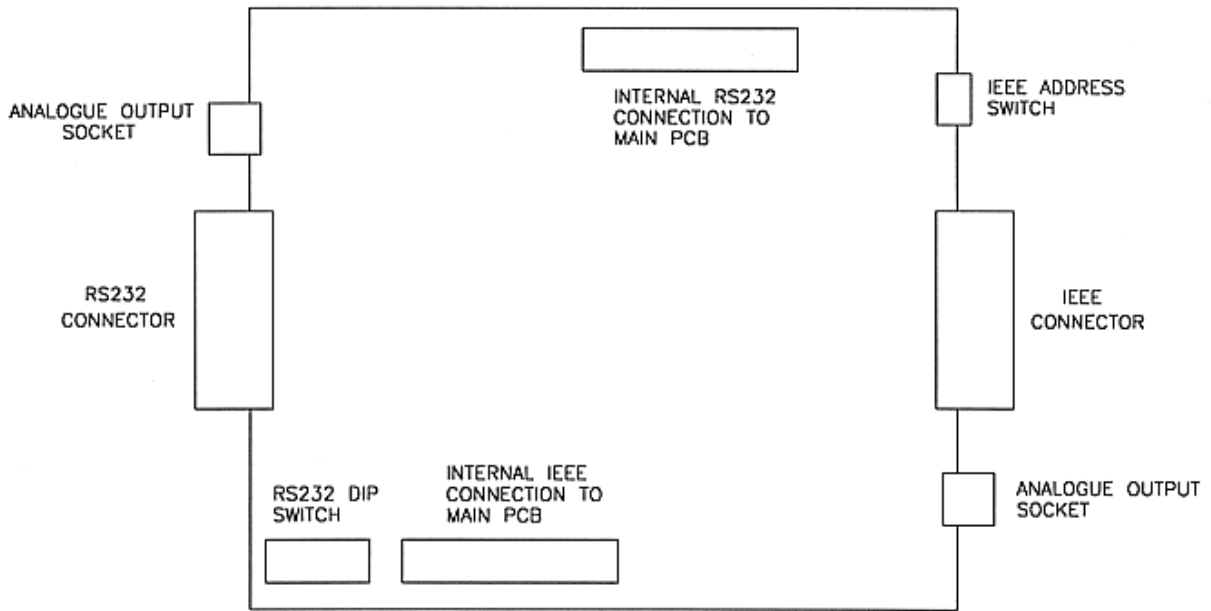

Figure 9-3. Board Layout

- iv) When a lever is in the down position, this is set in the ON or 1 position. The switches may be adjusted according to the following tables.

Baud Rate

Baud rate	Switch		
	1	2	3
4800	1	0	0
9600	1	1	0
19200	1	1	1

Parity

Parity	Switch	
	4	6
No Parity	1	1 or 0
Even Parity	0	1
Odd Parity	0	0

Data Bits

Bits	Switch
7 Bits	5
8 Bits	0
	1

Stop Bits

Stop bits	Switch
1 Stop Bit	7
2 Stop Bits	0
	1

NOTE: Switch 8 is not used.

Examples:

To set 19200 Baud, no parity, 8 data bits and 2 stop bits (the standard factory setting), set all switches down (ON) as follows:

Switch No	1	2	3	4	5	6	7	8
Position	1	1	1	1	1	1	1	1

To set 4800 Baud, no parity, 8 data bits and 1 stop bit, select the following:

Switch No	1	2	3	4	5	6	7	8
Position	1	0	0	1	1	x	0	x

Note: x = either a 1 or a 0

To set 9600 Baud, even parity, 8 data bits and 2 stop bits, select the following:

Switch No	1	2	3	4	5	6	7	8
Position	1	1	0	0	1	1	1	x

Note: x = either a 1 or a 0

When the settings have been made, replace the instrument top cover and secure the 4 mounting screws.

9.2.3 Command Delimiters

All commands must be delimited with a line feed character (ASCII 0A_H), that is the last character of a command string sent to the F250 must be the line feed (LF) character.

For example, to request a reading from the F250, the following "C" code could be used:

```
n=ComWrt("COM1","D\n",2); /* COM1 is the RS232 port, "D" is the reading request command, "\n" is
                           the line feed delimiter, 2 is the number of characters to be sent, n will
                           return the number of characters actually sent by ComWrt function */
```

Commands sent are executed after the F250 receives a line feed (LF), or carriage return/line feed (CR LF) combination.

9.2.4 Multiple Commands

Multiple commands may be sent, but if the input buffer within the F250, which stores incoming characters, becomes full (maximum 256 bytes including carriage return, CR, and line feed, LF), the commands are executed up to the last complete command in the buffer.

9.2.5 Data Timing

The F250 will normally return data within 100 milliseconds (0.1 sec.) after receiving any of the commands ?, Q, T or D if the baud rate is set to 19200. The controlling device must therefore be ready to receive as soon as the command is sent. All data returned is terminated with a carriage return/line (CR LF) feed sequence. No leading or trailing spaces are sent. When command "A" is used, the F250 sends data after every measurement update. Section 9.2.7, Commands and Syntax, gives full details of the command set.

9.2.6 Returned Data

A standard reading returned from PRT input A or B is 11 characters long, e.g. 'A962.000C\r\n', where '\r' represents a carriage return and '\n' a line feed. When reading Ohms in high resolution, the reading will be 12 characters long, e.g. 'A200.1234R\r\n'.

When the 'M' command is used to return a reading with the switchbox channel number, the complete reading will be 13 characters long for a standard reading, or 14 characters long when reading Ohms in high resolution, e.g. 'A962.000C00\r\n', 'A200.1234R01\r\n'. When the 'M' command is used to return the switchbox channel number and differential mode is selected (A-B), the reading will indicate both A and B channel numbers, e.g. 'D100.345C0015' where 'D' is differential mode, '100.345' is the temperature difference in degrees Celsius, '00' is the channel selected on switchbox A and '15' is the channel selected on switchbox B.

9.2.7 Commands and Syntax

All of the primary functions available from the F250 front panel can be accessed via the serial interface from an external computer or terminal.

Following is a list of the commands that can be sent to the F250: all are single letters which may be followed by up to 2 single digit parameters, with the exception of the switchbox commands which have 2 alphabetical characters followed by 2 digits.

COMMAND A

Function: Requests the F250 to return the PRT reading (temperature or resistance) and display units every time the display is updated. The PRT Input may be A, B or D (differential), and units may be C, F, K or W (when units are set to W (Ohms), data readings are returned followed by the letter "R").

Examples: "A 100.00C", "B273.150K", "D 20.1501R".

Note: the returned data is 9 characters long +CR+LF, except when units of Ohms are selected in high resolution mode when the data string is 10 characters long +CR+LF.

Syntax: An, where n = 0, 1, 2, 3 or 4

Parameters: n = 0 selects PRT A
n = 1 selects PRT B
n = 2 selects PRT A - B (differential)
n = 3 selects alternate mode (A then B)
n = 4 cancels continuous output

Initial State: n = 4

Note: Sets service request mask when used with IEEE interface see command "M" (below and in section 9.3.7) and section 9.4.1.

COMMAND C

Function: Clear or general reset - resets the F250 to its initial switch-on state.

Syntax: C

Parameters: None

Initial State: Not applicable

Note: this command does not require LF (line feed) delimiter

COMMAND F

Function: Sets the sensitivity of the analogue output (if installed).

Syntax: Fn, where n = 0, 1, 2 or 3

Parameters: n = 0 selects 10V/degree or 10V/Ohm
n = 1 selects 1V/degree or 1V/Ohm
n = 2 selects 0.1V/degree or 0.1V/Ohm
n = 3 selects 0.01V/degree or 0.01V/Ohm

Initial State: n = 3, 0.01V/degree or 0.01V/Ohm

COMMAND L

Function: Local lockout - enables or disables the F250 front panel controls.

Syntax: Ln, where n = 0 or 1

Parameters: n = 0 enables front panel (lockout off)
n = 1 disables front panel (lockout on)

Initial State: n = 0, lockout off

COMMAND M

Function: Requests the F250 to return the PRT reading (temperature or resistance) and display units every time the display is updated. The Input may be A, B or D (differential), and units may be C, F, K or W (when units are set to W (Ohms), data readings are returned followed by the letter "R").

Examples: "A 100.00C", "A273.150K02", "B100.1234R", "D120.1501R0404".
Note: the returned data is at least 9 characters long. When the channel number is sent, this is added as a 2 digit number following the units character. When units of Ohms are selected in high resolution mode, the reading is at least 10 characters long + CR + LF. When differential mode is selected and channel number indication is requested, both A and B channel numbers are returned. Returned data strings are always terminated by carriage return (CR) and line feed (LF) characters.

Syntax: Ma, where a = @, A,B,C,D,I,J,K or L
 Parameters: a = @ cancels continuous output
 a = A sets PRT to A and sends data when reading available.
 a = B sets PRT to B and sends data when reading available.
 a = C sets PRT to A-B and sends data when reading available.
 a = D sets PRT alternately to A then B and sends data when reading available.
 a = I sets PRT to A and sends data with channel number when reading available.
 a = J sets PRT to B and sends data with channel number when reading available.
 a = K sets PRT to A-B and sends data with channel number when reading available.
 a = L sets PRT alternately to A then B and sends data with channel number when reading available.

Initial State: a = @
Note: see also command **A** above and sections 9.4.1, 9.4.2

COMMAND P

Function: Set PRT input for display
 Syntax: Pn, where n = 0, 1 or 2
 Parameters: n = 0 selects the A PRT input for display
 n = 1 selects the B PRT input for display
 n = 2 selects A - B (differential) for display
 Initial State: n = 0, PRT A being measured and displayed

COMMAND ? or Q

Function: Query, the F250 will return the status of the function
 Syntax: ?a or Qa, where a is P, R, U, Z or _
 Parameters: a = P queries the PRT setting - return setting 0, 1 or 2 (see P command for parameters)
 a = R queries the resolution - return setting 0 or 1 (see R command for parameters)
 a = U queries the units - return setting 0, 1, 2 or 3 (see U command for parameters)
 a = Z queries the zero function - (0 = no zero set, 1 = zero set)
 a = _ queries all settings - returns reading + all settings. (25 characters +CR+LF normally, 26 characters +CR+LF in high res. with units set to Ohms).
 Initial State: Not applicable

COMMAND R

Function: Sets the F250 resolution to 2 or 3 decimal places
 Syntax: Rn, where n = 0 or 1
 Parameters: n = 0 selects 2 decimal places (3 decimal places for Ohms)
 n = 1 selects 3 decimal places (4 decimal places for Ohms)
 Initial State: n = 0

COMMAND S

Function: Remote control of the SB250-8, SB250-16 switchboxes (if installed)
Syntax: Smn, where m = A or B and n is a number 00 to 15
Parameters: m = A directs control to the switchbox on channel A
m = B directs control to the switchbox on channel B
n = the number of the channel on the selected switchbox
Initial State: SA00, SB00
Note: 4 characters must be sent to form a valid command, for example SA02, SB13

COMMAND T or D

Function: Asks the F250 to send the PRT reading and selected units. The PRT may be A, B or D (differential), resolution may be low or high and the units may be C, K, F or W (when units are set to W (Ohms), data readings are returned followed by the letter "R").
Examples: "A 0.003C", or "B 75.149K".
Note: the returned data string is 9 characters long +CR+LF in low resolution mode, but 10 characters long +CR+LF in high resolution mode when the selected units are Ohms.
Syntax: T or D
Parameters: None
Initial State: Not applicable

COMMAND U

Function: Sets the units on the SB250 to °C, °F, K or W (Ohms)
Syntax: Un, where n = 0, 1, 2 or 3
Parameters: n = 0 selects °C
n = 1 selects K
n = 2 selects °F
n = 3 selects W (Ohms)
Initial State: n = 0
Note: when units are set to W (Ohms), data readings are returned followed by the letter "R".

COMMAND Z

Function: Sets present reading to zero (null), or clears zero setting if already set
Syntax: Z
Parameters: None
Initial State: Zero not set

9.3 IEEE488 Interface

IEEE communication is via a 24-pin IEEE connector on the back panel.

If the IEEE option is installed, then the F250 will display its device address during the start up display routine as follows:

"IEEE n"
where n is the device number 1 to 7.

9.3.1 Pin Connections

Pin connections for IEEE488 are shown in Figure 9-4

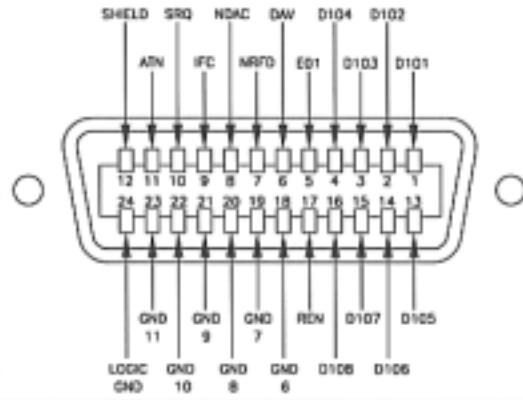

Figure 9-4. IEEE Connector

9.3.2 IEEE488 Address Selection

Address Selection: set the device address with the rotary switch located at the rear of the instrument on the interface panel. The switch has positions 0 to F, although only addresses 1 to 7 may be used. Positions 9 to F are the same as positions 1 to 7. Address 0 is used for the RS232C controller, so is not available for IEEE. The IEEE address switch is set at the factory to address 3. The address switch is interrogated only at power on or following a CLEAR command. If the address is changed while the F250 is switched on, it will continue to respond to the previous address until a CLEAR command is sent or the instrument power switched off, then on again.

The interface has no remote/local switching facility, so the F250 does not have to be switched “on-line” before commands are sent.

To return the F250 to its initial power on state, the IEEE488 device clear command can be used, which has the same effect as the CLEAR command.

Figure 9-5 shows the address selection switch.



Figure 9-5. Address Selection Switch

9.3.3 Specification

The IEEE488 interface fitted to the F250 complies with the IEEE488.1 (1987) standard and has the following specification:

- i) SH1 Full source handshake
- ii) AH1 Full acceptor handshake
- iii) T8 Basic talker (unaddress on MLA)
- iv) L4 Basic listener (unaddress on MLA)
- v) LE0 No extended addressing
- vi) TE0 No extended addressing
- vii) SR1 Service request available
- viii) RL0 No remote local function
- ix) LL0 No local lockout function (local lockout instrument command available)
- x) PP0 No parallel poll
- xi) DC1 Device clear - reverts to power-on state

9.3.4 Command Delimiters

All commands must be delimited with a line feed character (ASCII 0A_H), that is the last character of a command string sent to the F250 must be the line feed (LF) character.

For example, to request a reading from the F250, the following "C" code could be used:

```
ibwrt("F250","D\n",2); /* F250 is the IEEE device name, "D" is the reading request command, "\n" is the  
line feed delimiter, 2 is the number of characters to be sent by ibwrt function */
```

Commands sent are executed after the F250 receives a line feed (LF), or carriage return/line feed (CR LF) combination.

9.3.5 Multiple Commands

Multiple commands may be sent, but if the input buffer within the F250, which stores incoming characters, becomes full (maximum 256 bytes including carriage return, CR, and line feed, LF), the commands are executed up to the last complete command in the buffer.

9.3.6 Data Timing

The F250 will normally return data within 100 milliseconds (0.1 sec.) after receiving any of the commands ?, Q, T or D. The controlling device must therefore be ready to receive as soon as the command is sent.

All data returned is terminated with a carriage return/line feed (CR LF) sequence. No leading or trailing spaces are sent. See section 9.3.7, Commands and Syntax, for full details of the command set.

9.3.7 Commands and Syntax

All of the primary functions available from the F250 front panel can be accessed via the IEEE-488 interface from an external computer or terminal.

Following is a list of the commands that can be sent to the F250: all are single letters which may followed by up to 2 single digit parameters, with the exception of the switchbox commands which have 2 alphabetical characters followed by 2 digits.

COMMAND C

Function: Clear or general reset - resets the F250 to its switch-on state.
 Syntax: C
 Parameters: None
 Initial State: Not applicable
Note: this command does not require LF (line feed) delimiter

COMMAND F

Function: Sets the sensitivity of the analogue output (if installed).
 Syntax: Fn, where n = 0, 1, 2 or 3
 Parameters: n = 0 selects 10v/degree or 10v/Ohm
 n = 1 selects 1v/degree or 1v/Ohm
 n = 2 selects 0.1v/degree or 0.1v/Ohm
 n = 3 selects 0.01v/degree or 0.01v/Ohm
 Initial State: n = 3, 0.01v/degree or 0.01v/Ohm

COMMAND L

Function: Local lockout - enables or disables the F250 front panel controls.
 Syntax: Ln, where n = 0 or 1
 Parameters: n = 0 enables front panel (lockout off)
 n = 1 disables front panel (lockout on)
 Initial State: n = 0, lockout off

COMMAND M

Function: Sets Service Request Mask. The F250 sets the Request Service bit (RSV, bit 6) to indicate that data is available to be read. The type of data depends on the mask bits which are set.
 Syntax: Ma, where a = @, A,B,C,D,I,J,K or L
 Parameters: a = @ cancels Service Request
 a = A sets PRT to A and Service Request on when reading available.
 a = B sets PRT to B and Service Request on when reading available.
 a = C sets PRT to A-B and Service Request on when reading available.
 a = D sets PRT to alternate A then B and Service Request on when reading available.
 a = I sets PRT to A and Service Request on. Channel number will be returned with data when reading is requested.
 a = J sets PRT to B and Service Request on. Channel number will be returned with data when reading is requested.
 a = K sets PRT to A-B and Service Request on. Channel number will be returned with data when reading is requested.
 a = L sets PRT alternately to A then B and Service Request on. Channel number will be returned with data when reading is requested.
 Initial State: a = @
Note: see Section 9.4

COMMAND P

Function: Set PRT input for display
 Syntax: Pn, where n = 0, 1 or 2
 Parameters: n = 0 selects the A PRT input for display
 n = 1 selects the B PRT input for display
 n = 2 selects A - B (differential) for display
 Initial State: n = 0, PRT A being measured and displayed

COMMAND ? or Q

Function: Query, the F250 will return the status of the function
 Syntax: ?a or Qa, where a is P, R, U, Z or _
 Parameters: a = P queries the PRT setting 0, 1 or 2
 a = R queries the resolution setting 0 or 1
 a = U queries the units setting 0, 1, 2 or 3
 a = Z queries the zero function setting (0 = no zero set, 1 = zero set)
 a = _ queries all settings - returns reading + all settings (25 characters +CR+LF normally, 26 characters + CR+LF in high res. with units set to Ohms).
 Initial State: Not applicable

COMMAND R

Function: Sets the F250 resolution as 2 or 3 decimal places
 Syntax: Rn, where n = 0 or 1
 Parameters: n = 0 selects 2 decimal places (3 decimal places for Ohms)
 n = 1 selects 3 decimal places (4 decimal places for Ohms)
 Initial State: n = 0

COMMAND S

Function: Remote control of the SB250-8 and SB250-16 switchboxes (if used)
 Syntax: Smn, where m = A or B and n is a number 00 to 15
 Parameters: m = A directs control to the switchbox on channel A
 m = B directs control to the switchbox on channel B
 n = the number of the channel on the selected switchbox
 Initial State: SA00, SB00
Note: 4 characters must be sent to form a valid command, for example SA02, SB13.

COMMAND T or D

Function: Asks the F250 to send the PRT reading, resolution setting and selected units. The PRT may be A, B or D (differential), resolution may be low or high and the units may be C, K, F or W (when units are set to W (Ohms), data readings are returned followed by the letter "R").
 Examples: "A 0.003C", or "B 75.149K".
Note: the returned data string is 9 characters long +CR+LF in low resolution mode, but 10 characters long +CR+LF in high resolution mode when the selected units are Ohms.
 Syntax: T or D
 Parameters: None
 Initial State: Not applicable

COMMAND U

Function: Sets the units on the F250 to °C, °F, K or W (Ohms)
 Syntax: Un, where n = 0, 1, 2 or 3
 Parameters: n = 0 selects °C
 n = 1 selects K
 n = 2 selects °F
 n = 3 selects W (Ohms)
 Initial State: n = 0
Note: when units are set to W (Ohms), data readings are returned followed by the letter "R".

COMMAND Z

Function: Sets present reading to zero (null), or clears zero setting if already set
 Syntax: Z
 Parameters: None
 Initial State: Zero not set

9.4 Command "M" (Service Request Mask)

A Service Request Function is set up using the "M" command. The "M" command is issued with a single byte parameter (see the list below) which specifies the output required from the F250. When the Service Request command is issued, the F250 will raise the Request Service flag (RSV, bit 6) as often as the F250 completes a balance cycle and has a new reading available for output, until such time as a cancel command is received.

9.4.1 On-line Reading Display

The display on the F250 will be cleared whenever the PRT Input (A or B) is changed and whenever a switchbox channel selection is changed. This is to prevent data from a PRT Input or Channel being erroneously attributed to the new PRT Input or Channel selection. When scanning a number of PRTs on one or more switchboxes, only a short period of time may elapse between a reading becoming available for output at the completion of a balance cycle and switching to a different PRT Input or Channel, at which point the display will again be cleared. These actions will give the appearance of the display flashing the reading up only briefly before being cleared in readiness for reading the next Input or Channel.

9.4.2 Service Request Options

- | | |
|-----------|---|
| BIT 2,1,0 | |
| 000 | Cancel Service Request |
| 001 | set to channel A and set service request when data available |
| 010 | set to channel B and set service request when data available |
| 011 | set to channel A-B and set service request when data available |
| 100 | set alternately to channel A then B and set service request when data available |
| BIT 3 | Add switchbox channel number to the data output from the F250 |
| BIT 4 | Not used |
| BIT 5 | Not used |
| BIT 6 | RSV (Request Service Bit) |
| BIT 7 | Set F250 to return the error code when an error occurs |

Examples:

- i) To set PRT to A and set SRQ on data available, send the command "M" with the parameter 01000001 binary or "A" ASCII, i.e. send the command "MA" + line feed terminating character. On requesting data from the F250, it will be returned in the form "A 0.00C" (9 characters), "A100.1234R" (10 characters). The returned data string will be terminated by carriage return (CR) and line feed (LF) characters.
- ii) To set PRT to A then B alternately with switchbox channel number indication, send the command "M" with the parameter 01001100 binary or "L" ASCII, i.e. send the command "ML" + line feed terminating character. On requesting data from the F250, it will be returned in the form "A 0.00C01" (11 characters), "B -32.12C01" (11 characters). The returned data string will be terminated by carriage return (CR) and line feed (LF) characters.
- iii) To set PRT to D (differential) with switchbox channel number indication and set SRQ on data available, send the command "M" with the parameter 01001011 binary or "K" ASCII, i.e. send the command "MK" + line feed terminating character. On requesting data from the F250, it will be returned in the form "D 0.123C0101" (13 characters), or "D 0.1234R0101" (14 characters). The returned data string will be terminated by carriage return (CR) and line feed (LF) characters. The channel number indication '0101' indicates that switchbox A channel 1 and switchbox B channel 1 are currently selected for differential mode reading.
- iv) To cancel all service request conditions, send the command "M" with the parameter 01000000 binary or "@" ASCII, i.e. send the command "M@" + line feed terminator.

9.5 Analogue Output



Figure 9-6. Analogue Output

The F250 analogue output provides a DC output voltage in the range of ± 10 Volts d.c. F.S. that is directly proportional to the displayed reading and selected scaling factor. The analogue output is updated on completion of every balance cycle and is obtained from the digital measurement by digital to analogue conversion.

9.5.1 Default Settings

On power up, the F250 will initialize with the following settings:

Measurement units	deg C
Measurement PRT Input	PRT Input A
Resolution	low resolution
Analogue output scaling factor	1000

9.5.2 Scaling Factor

The analogue output full scale voltage can be scaled to represent a change in displayed units of 1, 10, 100 or 1000 (displayed units may be °C, °F, or Ohms). To view or alter the scaling factor of the analogue output, enter the scaling factor menu by pressing the "-" (minus) key of the data entry keypad. The display will flash "An-OP" to indicate that the analogue output menu has been entered. The display will then cycle through the available scaling factor options with the associated data entry key for each scaling factor selection.

To indicate the current scaling factor, the scaling factor number will flash repeatedly. To select a different scaling factor, press the appropriate key number associated with the required scaling factor.

Data Entry Key	Scaling Factor	Sensitivity
"0"	1	10V /degree or 10V /Ohm
"1"	10	1V /degree or 1V /Ohm
"2"	100	0.1V /degree or 0.1V /Ohm
"3"	1000	0.01V /degree or 0.01V /Ohm

Pressing the appropriate data entry key number will change the scaling factor and flash the changed setting on the display. The F250 will store the changed setting then return to run mode. On completion of the next balance cycle, the analogue output will be updated.

The scaling factor may also be set via the RS232 or IEEE interfaces (if installed) by sending the command Fn, where n = 0, 1, 2 or 3 as displayed in the table above. For example sending the command "F3" will set a scaling factor of 1000.

9.5.3 Analogue Output Connection

Connection to the analogue output is via an insulated BNC output socket on the rear panel of the F250 interface/output board. Connection to peripheral equipment should be made via a suitable twin core, twisted pair screened cable, (see Figure 9-7), to the instrumentation input amplifier of the peripheral equipment.

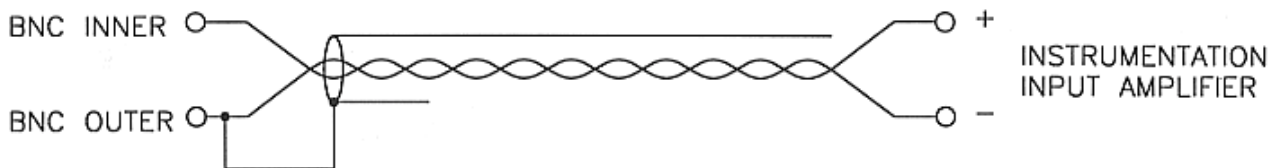

Figure 9-7. Twin Core, Twisted Pair, Screened Cable

9.5.4 Analogue Output Operation

The F250 analogue output provides a DC output voltage in the range of ±10 Volts d.c. F.S. that is directly proportional to the displayed reading and selected full scale reading (1,10,100 or 1000). The analogue output is updated on completion of every balance cycle.

Specification

Resolution 16 bit

Analogue Output range $\pm 10V$ DC F.S.

Scaling (front panel selectable) ± 1 , ± 10 , ± 100 , ± 1000 degrees

Linearity $\pm 0.0015\%$ FS typical ($\pm 0.3mV$)

Linearity $\pm 0.003\%$ FS max ($\pm 0.6mV$)

Monotonicity 14 bit

Resolution Per Scaled Range

Scale	Analogue Output	F250
1000 degrees	0.3mV d.c.	30mK
100 degrees	0.3mV d.c.	3mK
10 degrees	1mV d.c.	1mK
1 degree	10mV d.c.	1mK

Temperature Coefficient

Gain drift	$\pm 10ppm/^{\circ}C$ typical $\pm 25ppm/^{\circ}C$ max
Zero drift	$\pm 5ppm$ FS/ $^{\circ}C$ typical $\pm 12ppm$ FS/ $^{\circ}C$ max

10. Error Codes

Error codes can be generated by the F250 for a variety of reasons as follows.

Code	Meaning / Cause
E1	Balance error / No PRT, PRT open circuit / Ratio over range.
E2	Temperature over range / PRT at temperature outside limits of conversion table.
E3	No "A" ROM calibration/ No ROM calibration on selected Input or Channel
E4	IEEE or RS232 error / Unrecognized instruction sent
E5	IEEE or RS232 error / Illegal argument sent
E6	RAM failure
E7	Data validation error in CAL ROM "A" or "B" - PRT calibration invalid
E8	Unable to track temperature change / temperature change too large
E9	Conversion table too big (more than 395 points)/ Resistance range too great
E10	Unable to create resistance/temperature conversion table.
E11	Unable to create resistance/temperature conversion table.

Error codes E10 and E11 are likely to occur only very rarely, will only occur when entering a Callendar van Dusen temperature/resistance calibration when the data entered causes a singular matrix to be created during coefficient generation. This may be the result of entering identical pairs of data (or data which appears identical following rounding). It may be overcome by rearranging the input data.

11. Options and Accessories

11.1 Communications/Output Options

Communications/Output options can generally be retro-fitted to an existing F250.

11.2 Accessories

Order Suffix	Description
INT-RS	RS232C Communications
INT-IEEE	IEEE 488 Communications
INT-AN	Analogue Output
SB250-8	8 Channel Switchbox
SB250-16	16 Channel Switchbox

Part Number	Description
SOFT250	LabWindows PC software for F250
FA-DT	DIN plug to 5-pin screw terminal plug converter
FA-TD	5-pin screw terminal to DIN plug converter
FA-CC250	Hard carry case
FA-SC250	Soft carry case

11.3 High ∞ PRTs

	Type T100-650-1 D	Type T100-450-3 D	Type T100-450-4 D
R₀	100 Ω	100 Ω	100 Ω
∞	0.00392	0.003916	0.00390
Range	-189°C to +650°C	-100°C to +450°C	-100°C to +450°C
Sheath	Fused Silica	Stainless Steel	Stainless Steel
Sheath size	450mm x 7mm	450mm x 6.35mm	450mm x 6.35mm
Cable Length	2 meters	2 meters	2 meters

	Type T25-650-1 D
R_0	25.5 Ω
α	> 0.003926
Range	-189°C to +650°C
Sheath	Fused Silica
Sheath size	450mm x 7.0mm
Cable Length	2 meters

11.4 Low α PRTs

	Type T100-600-1 D	Type T100-250-1 D	Type T100-450-1 D	Type T100-200-1 D
R_0	100 Ω	100 Ω	100 Ω	100 Ω
α	<0.00390, typically 0.00385	<0.00390, typically 0.00385	<0.00390, typically 0.00385	<0.00390, typically 0.00385
Range	-50°C to +600°C	-50°C to +250°C	-70°C to +450°C	-50°C to +200°C
Sheath	Fused Silica	Stainless Steel	Stainless Steel	Stainless Steel
Sheath size	460mm x 6mm	350mm x 6mm	350mm x 6mm	30mm x 3mm
Cable Length	2 meters	2 meters	2 meters	3 meters

	Type T100-450-2 D	Type T10-962-1 D	Type T10-962-2 D	Type T10-962-3D	Type T10-962-4D
R_0	100 Ω	10.0 Ω	10.0 Ω	10.0 Ω	10.0 Ω
α	0.00385	0.00397	0.00397	0.00397	0.00397
Range	-100°C to +450°C	0°C to +962°C	0°C to +962°C	0°C to +962°C	0°C to +962°C
Sheath	Stainless Steel	Ceramic	Ceramic	Ceramic	Ceramic
Sheath size	450mm x 6.35mm	305mmx6.35mm	406mm x 6.35mm	508mm x 6.35mm	610mm x 6.35mm
Cable Length	2 metres	2.44 metres	2.44 metres	2.44 metres	2.44 metres

12. Specifications

12.1 Accuracy

System accuracy is the combined accuracy of the F250 plus the calibration uncertainty of the PRT . The instrument and system accuracy's with a variety of PRTs are shown below.

F250 Only:- $\pm 4 \text{ m}\Omega$, equivalent to

$\pm 10\text{mK}$ with PT100 PRT
$\pm 40\text{mK}$ with PT25 PRT
$\pm 100\text{mK}$ with PT10 PRT

F250 + T100-250-1D PRT (-50°C to +250°C)

-50°C	0°C	+100°C	+250°C
$\pm 25\text{mK}$	$\pm 25\text{mK}$	$\pm 25\text{mK}$	$\pm 25\text{mK}$

F250 + T100-450 1D PRT (-70°C to +450°C)

-70°C	-40°C	0°C
$\pm 45\text{mK}$	$\pm 25\text{mK}$	$\pm 25\text{mK}$
+100°C	+250°C	+450°C
$\pm 25\text{mK}$	$\pm 25\text{mK}$	$\pm 100\text{mK}$

F250 + T100-650-1D PRT (-200°C to 650°C)

-189°C	0°C	+100°C
$\pm 20\text{mK}$	$\pm 20\text{mK}$	$\pm 20\text{mK}$
+420°C	+550°C	
$\pm 20\text{mK}$	$\pm 35\text{mK}$	

F250 + uncalibrated 100 Ohm DIN PRT (see Section 7 for Internationally recognized PRT categories).

Typical figures only - 1/3rd DIN

0°C	+100°C	+250°C
$\pm 110\text{mK}$	$\pm 280\text{mK}$	$\pm 530\text{mK}$

12.2 Resolution

User selectable via front panel or via interface (if installed).

Low resolution: 0.01°C, 0.01°F, 0.01K, 0.01Ω (on display) or 0.001Ω (via interface).
Display update rate is approximately every 0.5 seconds

High resolution: measurements <1000 = 0.001°C, 0.001°F, 0.001K, 0.001Ω (on display) or 0.0001Ω (via interface). Display update rate is approximately every 2.5 seconds.

measurements ≥ 1000 = 0.01°C, 0.01°F, 0.01K, 0.01Ω display
or 0.001Ω (via interface)

12.3 Stability

Temperature Coefficient: $\pm 0.0005^{\circ}\text{C}/^{\circ}\text{C}$ ($0.5\text{mK}/^{\circ}\text{C}$) - Based on Pt100 PRT

Term Stability: Typically better than $\pm 5\text{mK}/\text{year}$ ($\pm 0.005^{\circ}\text{C}/\text{year}$) - Based on Pt100 PRT

12.4 General Features

Measurement:	4-wire, auto-balance AC resistance ratio bridge.
Carrier Frequency:	375Hz
Display:	6 digit, filtered vacuum fluorescent display, indicating in $^{\circ}\text{C}$, $^{\circ}\text{F}$, K and Ω (Ohms). Update: 0.5/2.5 seconds in low/high resolution respectively.
PRT current:	1mA, constant current source.
PRT cables:	4 core + screen, 2 meters standard. Alternative cable lengths to special order. (See Section 7 for more PRT information.)
PRT Input Connectors:	Front Panel - 5 pin DIN professional sockets. Rear Panel - 5 pin screw terminal sockets (Front and rear connections are connected in parallel)
Digital Interface (Option):	RS232C serial and/or IEEE488 parallel interface available as options (see sections 9.2 - 9.4).
Analogue Output (Option):	$\pm 10\text{V}$ DC FS output is available as an option, resolution 1mK or 10 mK depending on front panel resolution setting. Linearity $\pm 0.05\%$ full scale. (See section 9.5)

12.5 Measurement Range

Dependent primarily on the PRT used - typically from -200°C to $+962^{\circ}\text{C}$, Automatic Systems Laboratories can advise on suitable PRTs. See Section 7 on suitable sensors.

12.6 Environment

Operating Temperature:	15°C to 25°C for full accuracy, 0°C to 50°C maximum.
Humidity:	Specified to 90% RH at 40°C non-condensing.
Power Requirements:	240 VAC $\pm 8\%$; 220 VAC $\pm 8\%$, 120 VAC $\pm 8\%$ or 100 VAC $\pm 8\%$. Supply Voltage range is user selectable on rear panel.
Frequency Range:	47-63Hz
Power consumption:	30VA max
Dimensions:	Metal case with adjustable rest/handle, 240mm deep (front to back) x 260mm wide x 80mm high (9.45" deep x 10.24" wide x 3.15" high)
Weight:	2.6kg (5.72lbs)

13. Cleaning and Maintenance

13.1 Cleaning

Make sure the F250 is turned off and unplug the mains supply cable.

Clean the outside of the instrument with a soft, clean cloth dampened with mild detergent. Do not allow water to enter the instrument.



WARNING Never use alcohol or thinners as these will damage the instrument.

Never use a hard or abrasive brush.

13.2 Preventive Maintenance



WARNING Regular inspection of the mains supply cable is required to ensure that the insulation is not damaged.

13.3 General safety Warning



WARNING If the F250 is used in a manner not specified by ASL, then the protection provided by the instrument may be impaired.

14. Service and Warranty

F250 equipment and accessories, (unless stated otherwise), are covered by a 24 month warranty for parts and labor, but not including costs incurred in returning it to the factory for repair, from the date of dispatch from Automatic Systems Laboratories.

14.1 Technical Support

For all technical support, repair, warranty and service inquiries please contact:

ASL Inc.,
Druck Incorporated
4 Dunham Drive
Fairfield
CT 06812
USA

Telephone: 978 658 0000
Fax: 978 658 5444
E-Mail: aslinc@aslinc.com
Web page: www.aslinc.com

14.2 Returned Instruments

All returned goods should be sent carriage paid insured and packed well, to the above address.

14.3 Documentation

The shipment should include:

- i) Your goods return note, a delivery note or an export invoice clearly stating **GOODS RETURNED FOR REPAIR**.
- ii) Your Company / Establishment order or contract reference number.
- iii) The name of your purchasing and technical contact.
- iv) A brief fault report.

14.4 Repair Quotations

We shall be pleased to advise estimated repair costs upon receipt and initial inspection of returned goods.

NOTES

NOTES