

C1900 Series Circular Chart Recorders

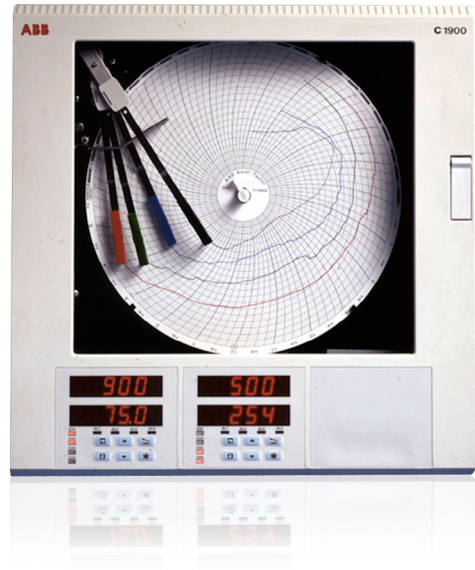

The Company

We are an established world force in the design and manufacture of measurement products for industrial process control, flow measurement, gas and liquid analysis and environmental applications.

As a part of ABB, a world leader in process automation technology, we offer customers application expertise, service and support worldwide.

We are committed to teamwork, high quality manufacturing, advanced technology and unrivalled service and support.

The quality, accuracy and performance of the Company's products result from over 100 years experience, combined with a continuous program of innovative design and development to incorporate the latest technology.

EN ISO 9001:2000



Cert. No. Q 05907

EN 29001 (ISO 9001)



Lenno, Italy – Cert. No. 9/90A

Stonehouse, U.K.



Electrical Safety

This equipment complies with the requirements of CEI/IEC 61010-1:2001-2 'Safety Requirements for Electrical Equipment for Measurement, Control and Laboratory Use'. If the equipment is used in a manner NOT specified by the Company, the protection provided by the equipment may be impaired.

Symbols

One or more of the following symbols may appear on the equipment labelling:

	Warning – Refer to the manual for instructions
	Caution – Risk of electric shock
	Protective earth (ground) terminal
	Earth (ground) terminal

	Direct current supply only
	Alternating current supply only
	Both direct and alternating current supply
	The equipment is protected through double insulation

Information in this manual is intended only to assist our customers in the efficient operation of our equipment. Use of this manual for any other purpose is specifically prohibited and its contents are not to be reproduced in full or part without prior approval of the Technical Publications Department.

Health and Safety

To ensure that our products are safe and without risk to health, the following points must be noted:

1. The relevant sections of these instructions must be read carefully before proceeding.
2. Warning labels on containers and packages must be observed.
3. Installation, operation, maintenance and servicing must only be carried out by suitably trained personnel and in accordance with the information given.
4. Normal safety precautions must be taken to avoid the possibility of an accident occurring when operating in conditions of high pressure and/or temperature.
5. Chemicals must be stored away from heat, protected from temperature extremes and powders kept dry. Normal safe handling procedures must be used.
6. When disposing of chemicals ensure that no two chemicals are mixed.

Safety advice concerning the use of the equipment described in this manual or any relevant hazard data sheets (where applicable) may be obtained from the Company address on the back cover, together with servicing and spares information.

CONTENTS

Section	Page
1 INTRODUCTION	1
2 SETTING UP	2
2.1 Instrument Power-up	2
2.1.1 Power-up Error Codes	3
2.2 Fitting the Chart	4
2.3 Fitting the Pen Capsule(s)	4
3 DISPLAYS & CONTROLS	5
3.1 Displays and LED Indicators	5
3.2 Use of Controls	6
4 OPERATION	7
4.1 Input Error Messages	8
4.2 Operating Page Displays	9
4.3 Alarm Acknowledge Page	10
4.3.1 Alarm Indications	10
4.3.2 Acknowledging Alarms	10
4.3.3 Using the Alarm Acknowledge Page	10
4.4 Totals Page Displays	11
4.5 Access to Configuration Levels	12
5 SIMPLE FAULT FINDING	13
6 SPARES LIST	14

1 INTRODUCTION

The documentation for the C1900 series of circular chart recorders is shown in Fig. 1.1. The **Standard Manuals**, including the data sheet, are supplied with all instruments. The **Supplementary Manuals** supplied depend on the specification of the instrument.

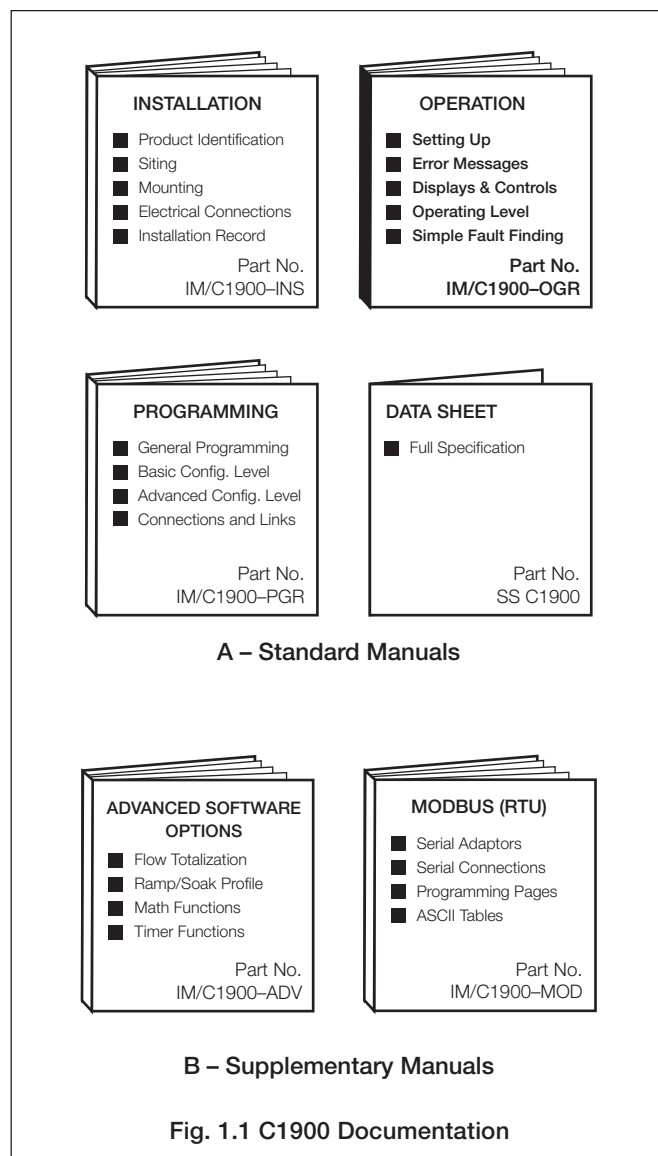

2 SETTING UP

2.1 Instrument Power-up – Fig. 2.1 and 2.2

Caution. Ensure that all connections, especially to the earth stud, are made correctly.

- Check that the input sensors are installed correctly.
- Check that the pen(s) are installed correctly – see Fig. 2.1.
- Switch on the supply to the instrument, any power-operated control circuits and the input signals. Wait for the pens to settle.

Note. On power-up, the pens are moved to an off-chart position for automatic referencing. Pen chatter may occur on those pens nearest the reference position. **This is a normal function of the instrument.**

- The start-up sequence shown in Fig. 2.2 is displayed on faceplate 1 when the supply is first switched on.

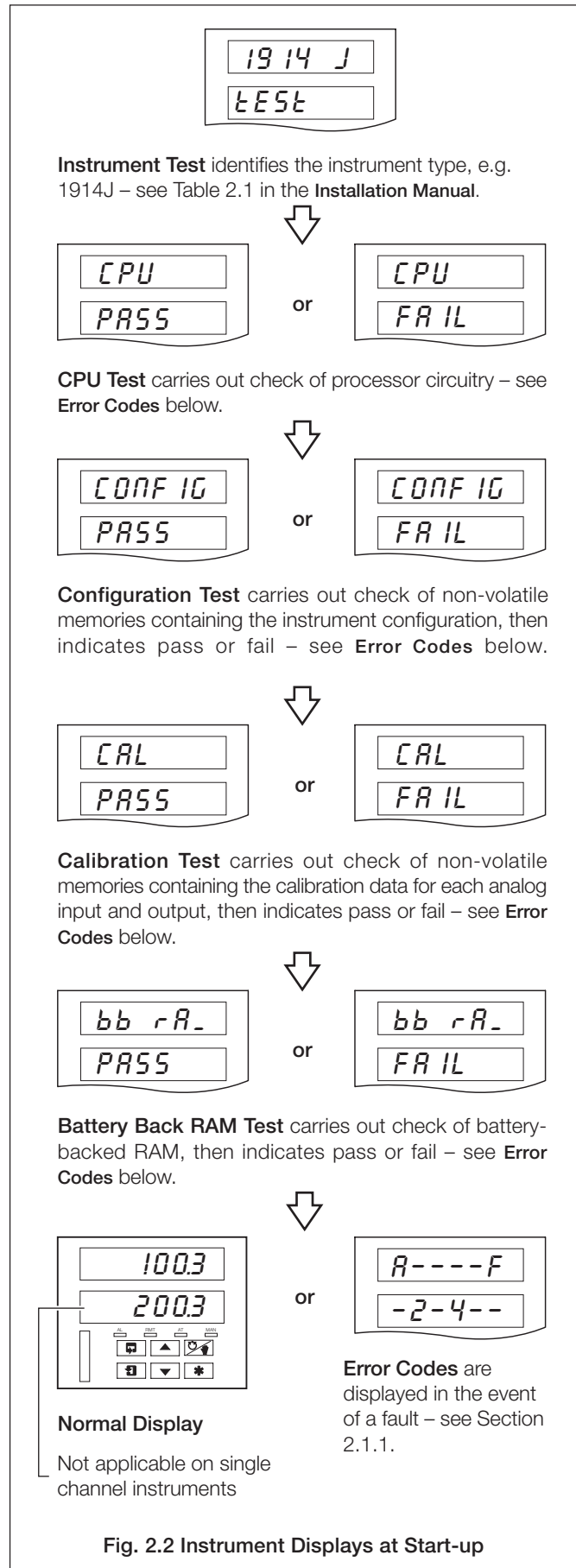
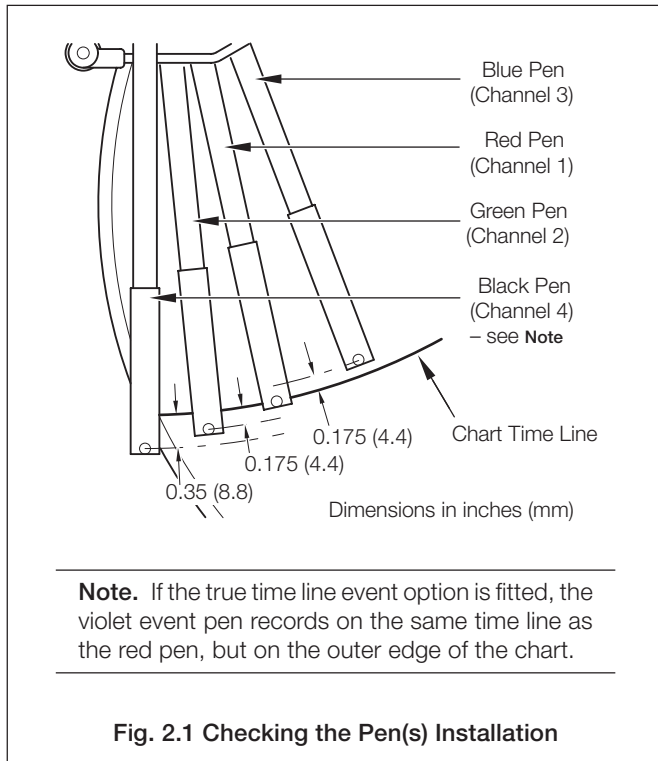

2.1.1 Power-up Error Codes

If any of the power-up tests fail (see Fig. 2.2), error codes are displayed to identify the fault. Refer to Fig. 2.3 for error code interpretations.

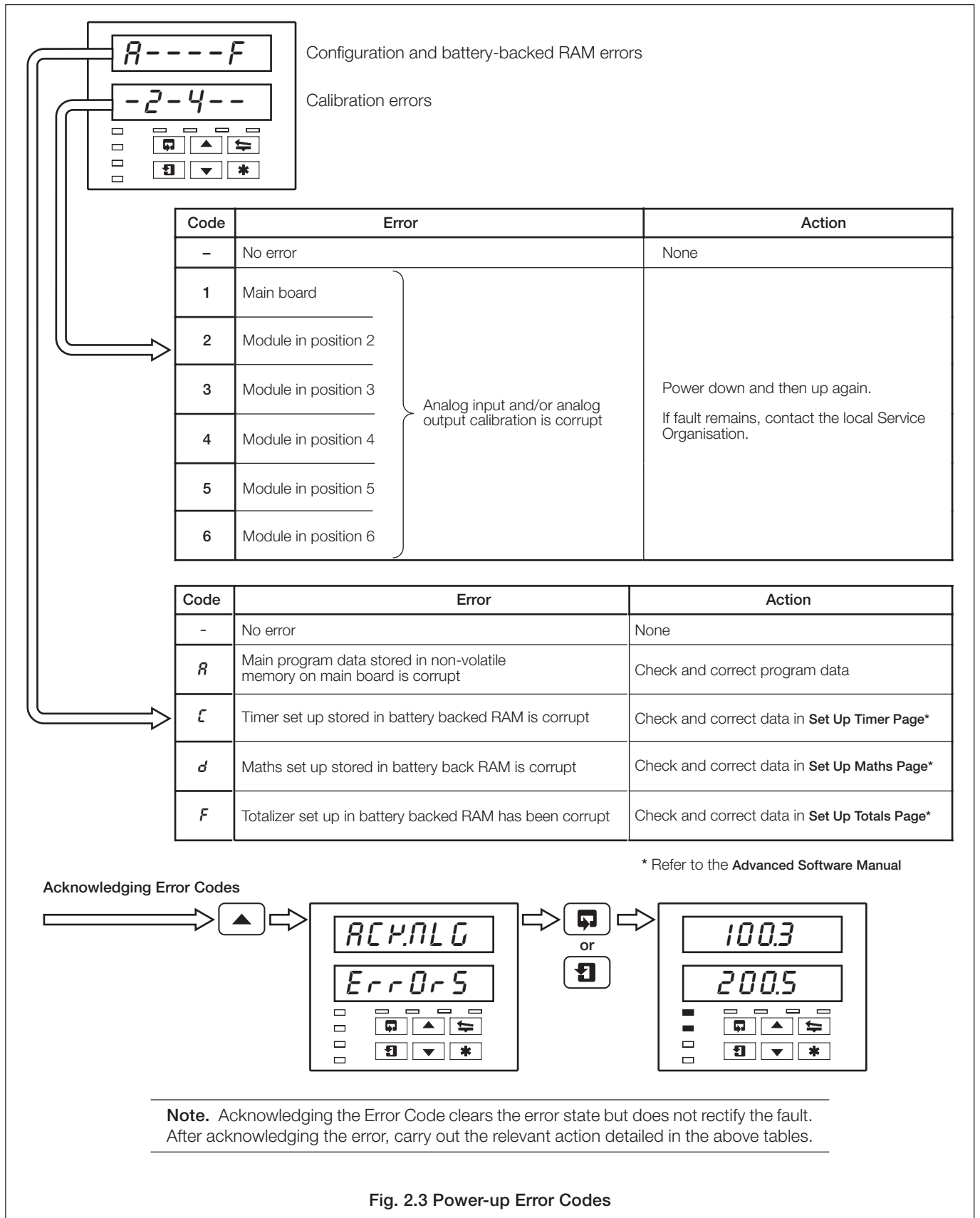
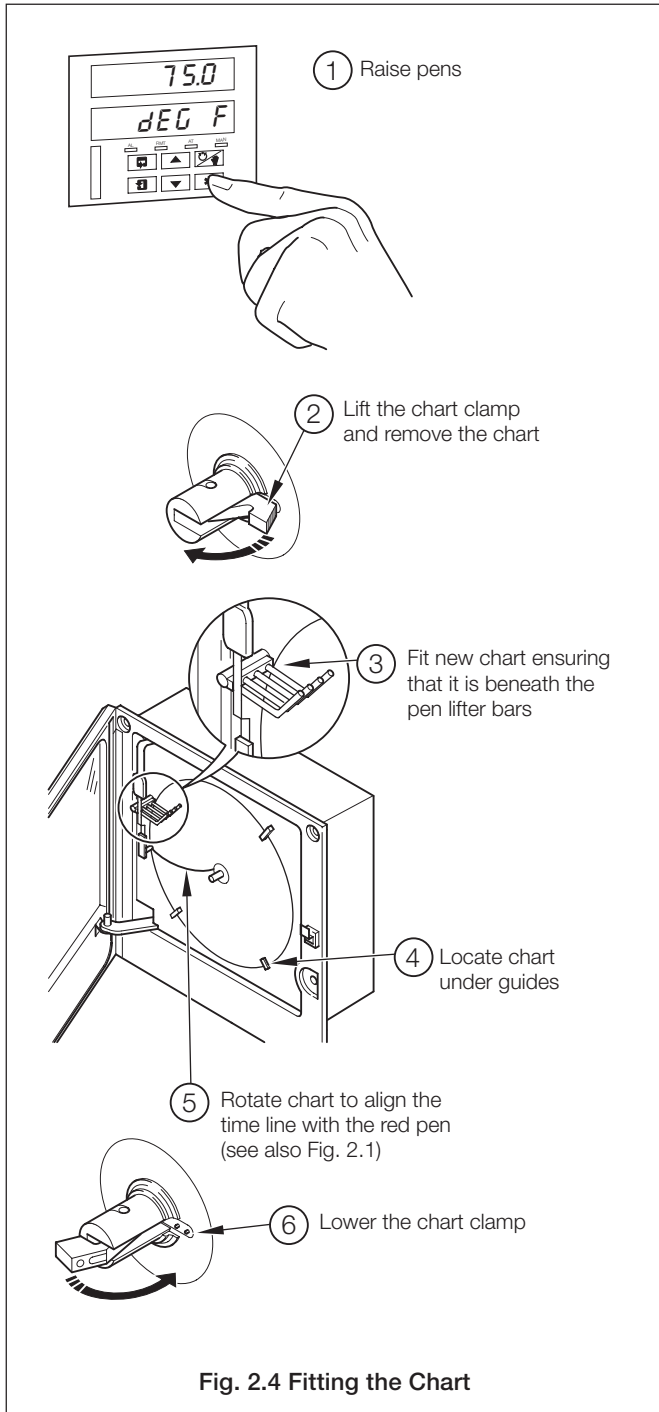
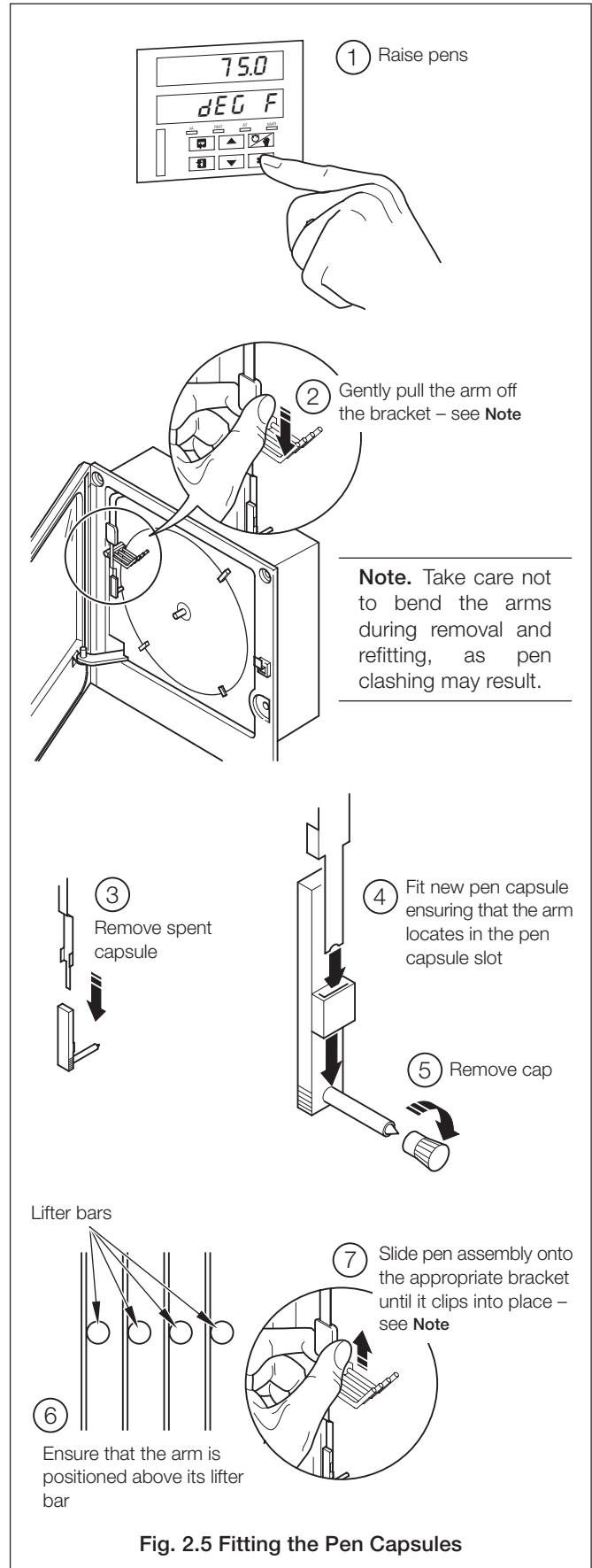

Fig. 2.3 Power-up Error Codes

2.2 Fitting the Chart – Fig. 2.4



2.3 Fitting the Pen Capsule(s) – Fig. 2.5



3 DISPLAYS & CONTROLS

The displays, LED indicators and operation/programming controls are located on the faceplate on the front panel of the instrument – see Fig 3.1.

3.1 Displays and LED Indicators – Fig. 3.1

The displays comprise 2 rows of 6 characters.

At the top of each programming page (the page header) both displays are used to describe the particular page selected.

When parameters within the selected page are viewed the upper display shows the parameter and the lower display shows the value or setting for that parameter.

Alarm and Channel states are indicated by separate LEDs on the faceplate of the front panel of the instrument – see Sections 4.1, 4.2 and 4.3.

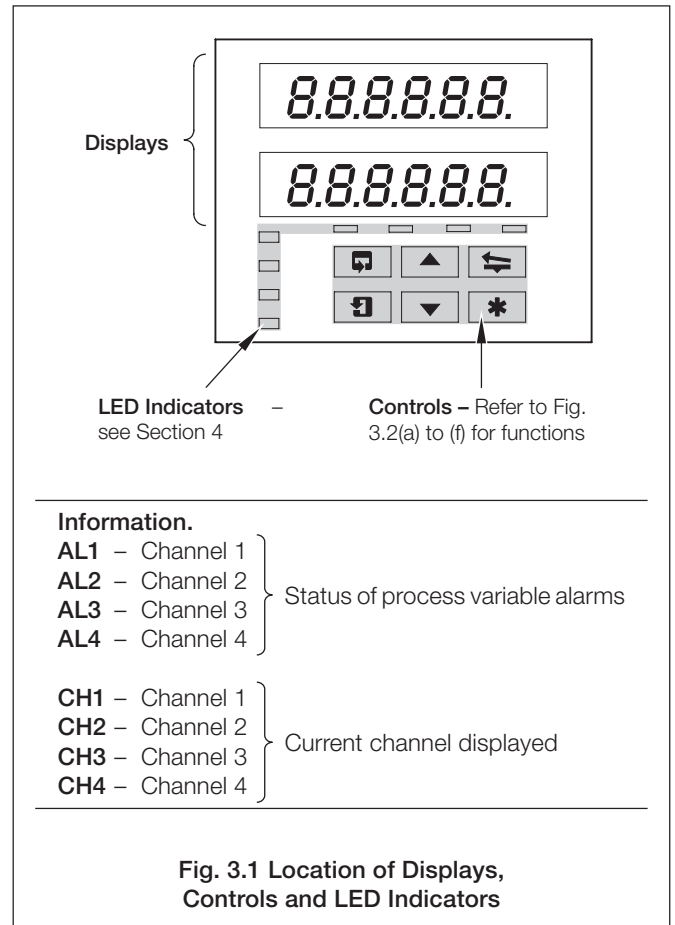

A	<i>A</i>	L	<i>L</i>
B	<i>b</i>	M	<i>-</i>
C	<i>C</i> or <i>c</i>	N	<i>n</i> or <i>n</i>
D	<i>d</i>	O	<i>0</i> or <i>o</i>
E	<i>E</i>	P	<i>P</i>
F	<i>F</i>	Q	<i>Q</i>
G	<i>G</i>	R	<i>r</i>
H	<i>H</i> or <i>h</i>	S	<i>S</i>
I	<i>I</i>	T	<i>t</i>
J	<i>J</i>	U	<i>U</i>
K	<i>K</i>	V	<i>V</i>
		Y	<i>Y</i>

Table 3.1 Character Set

3.2 Use of Controls – Fig. 3.2(a) to (f)

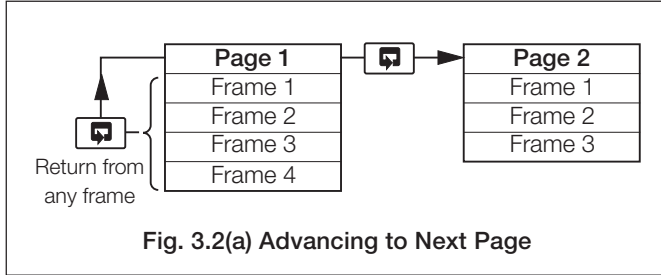

Fig. 3.2(a) Advancing to Next Page

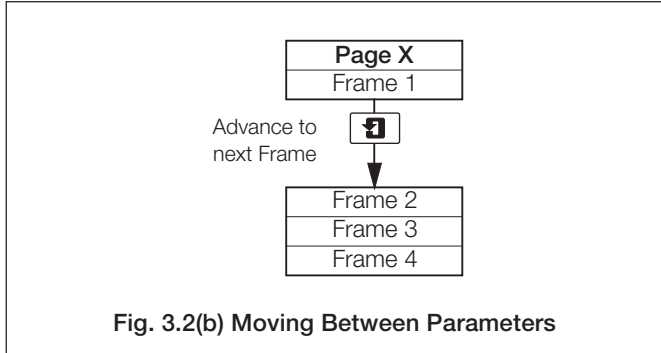
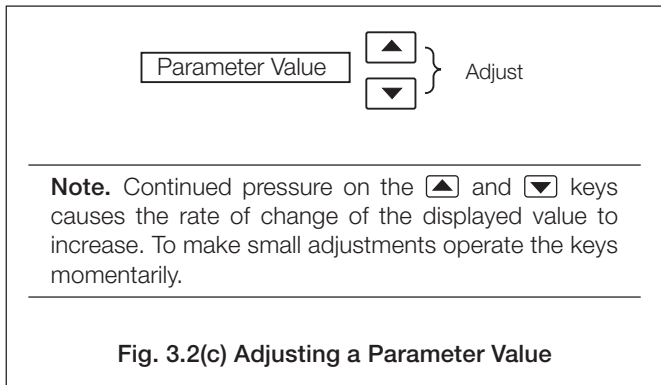
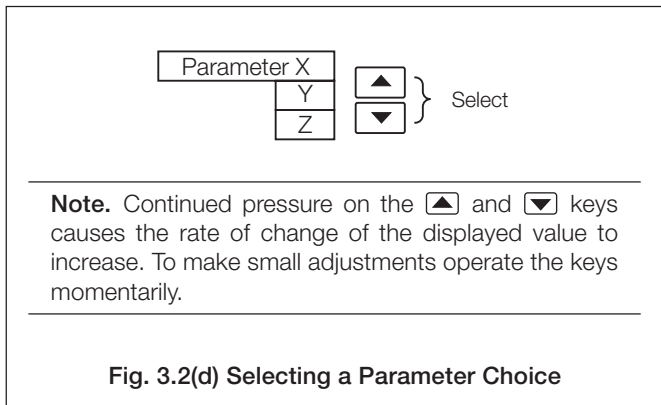

Fig. 3.2(b) Moving Between Parameters



Note. Continued pressure on the ▲ and ▼ keys causes the rate of change of the displayed value to increase. To make small adjustments operate the keys momentarily.

Fig. 3.2(c) Adjusting a Parameter Value



Note. Continued pressure on the ▲ and ▼ keys causes the rate of change of the displayed value to increase. To make small adjustments operate the keys momentarily.

Fig. 3.2(d) Selecting a Parameter Choice

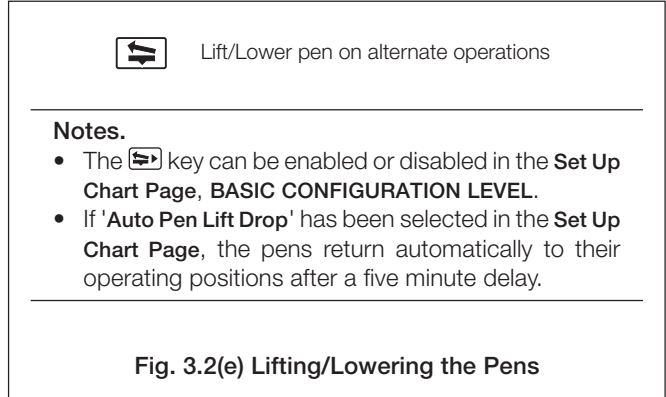
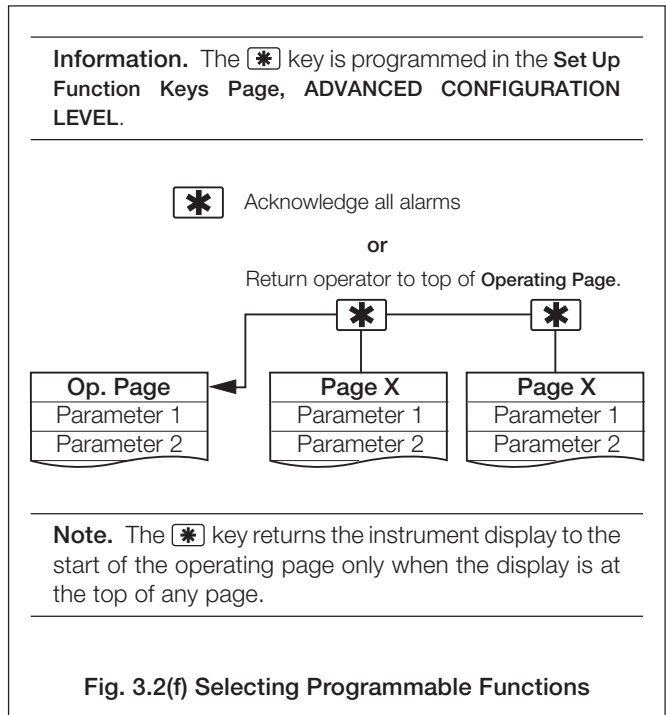

Fig. 3.2(e) Lifting/Lowering the Pens



Note. The key returns the instrument display to the start of the operating page only when the display is at the top of any page.

Fig. 3.2(f) Selecting Programmable Functions

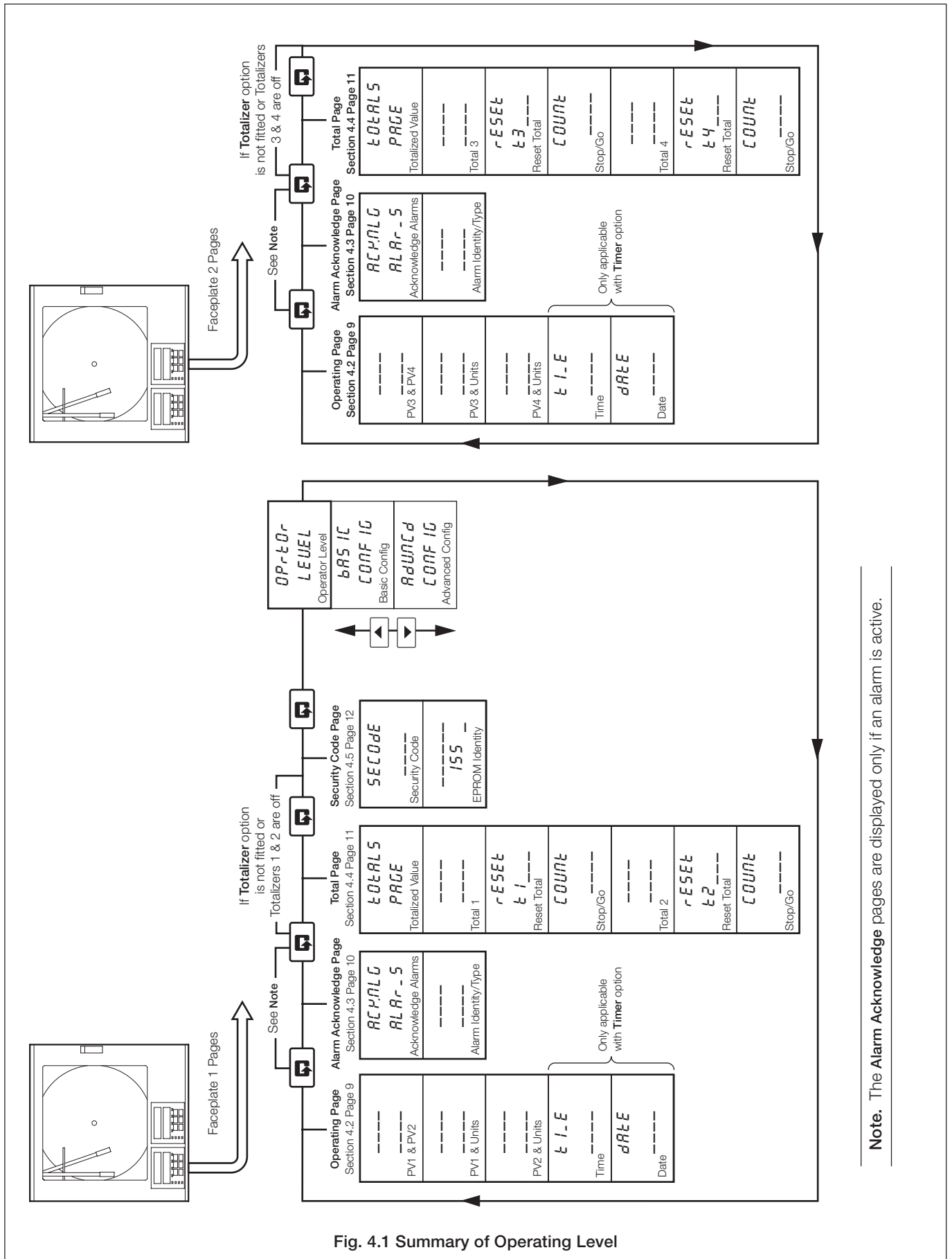
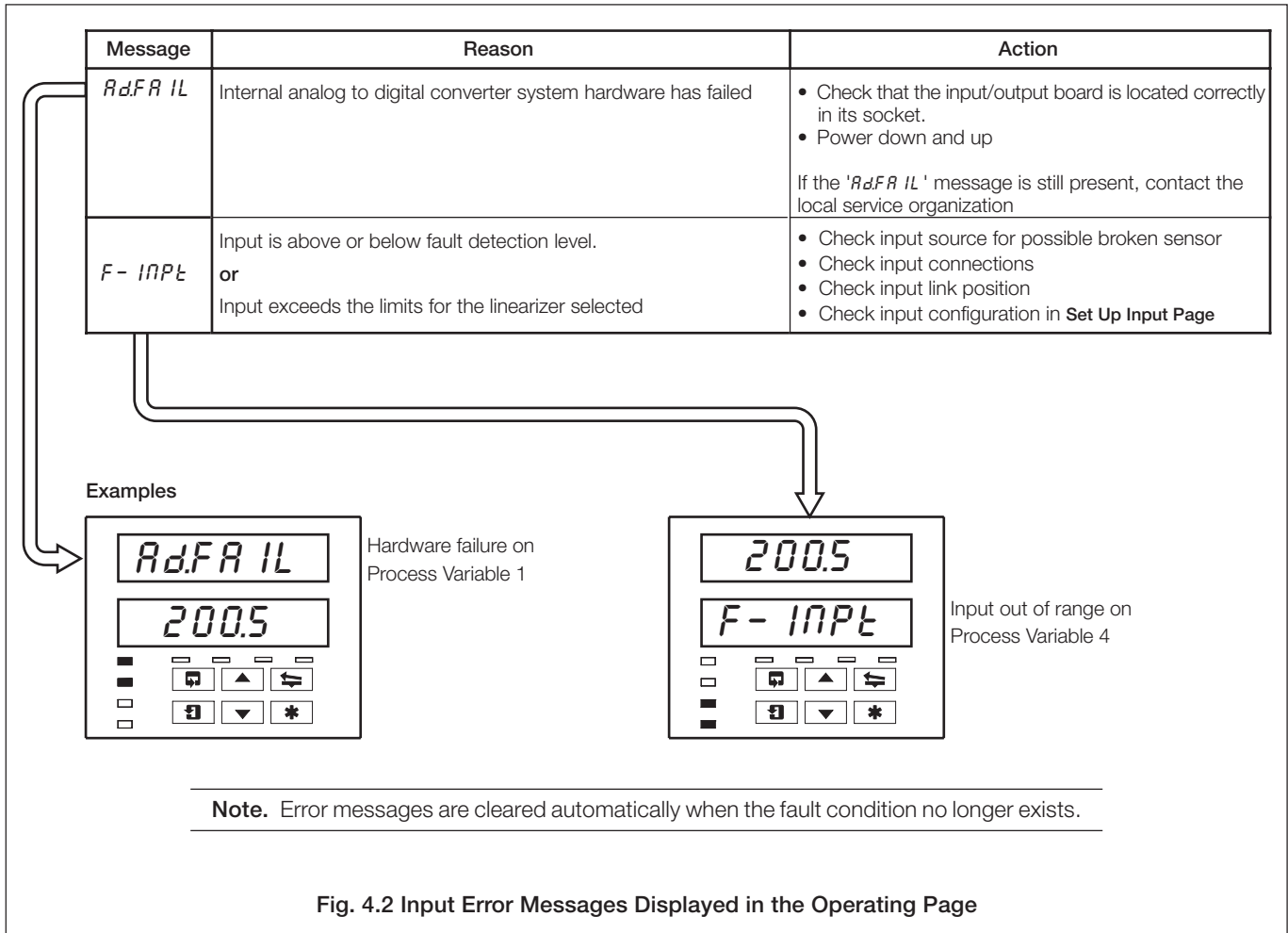

Fig. 4.1 Summary of Operating Level

Note. The Alarm Acknowledge pages are displayed only if an alarm is active.

The instrument has dedicated **Operating Pages** in the **OPERATOR LEVEL** – see Sections. 4.1 to 4.4. These pages are used for general monitoring of the process measurements and are not affected by the security system which inhibits access to the **PROGRAMMING LEVELS** only – see Section 4.5 on page 12.

4.1 Input Error Messages – Fig. 4.2



4.2 Operating Page Displays

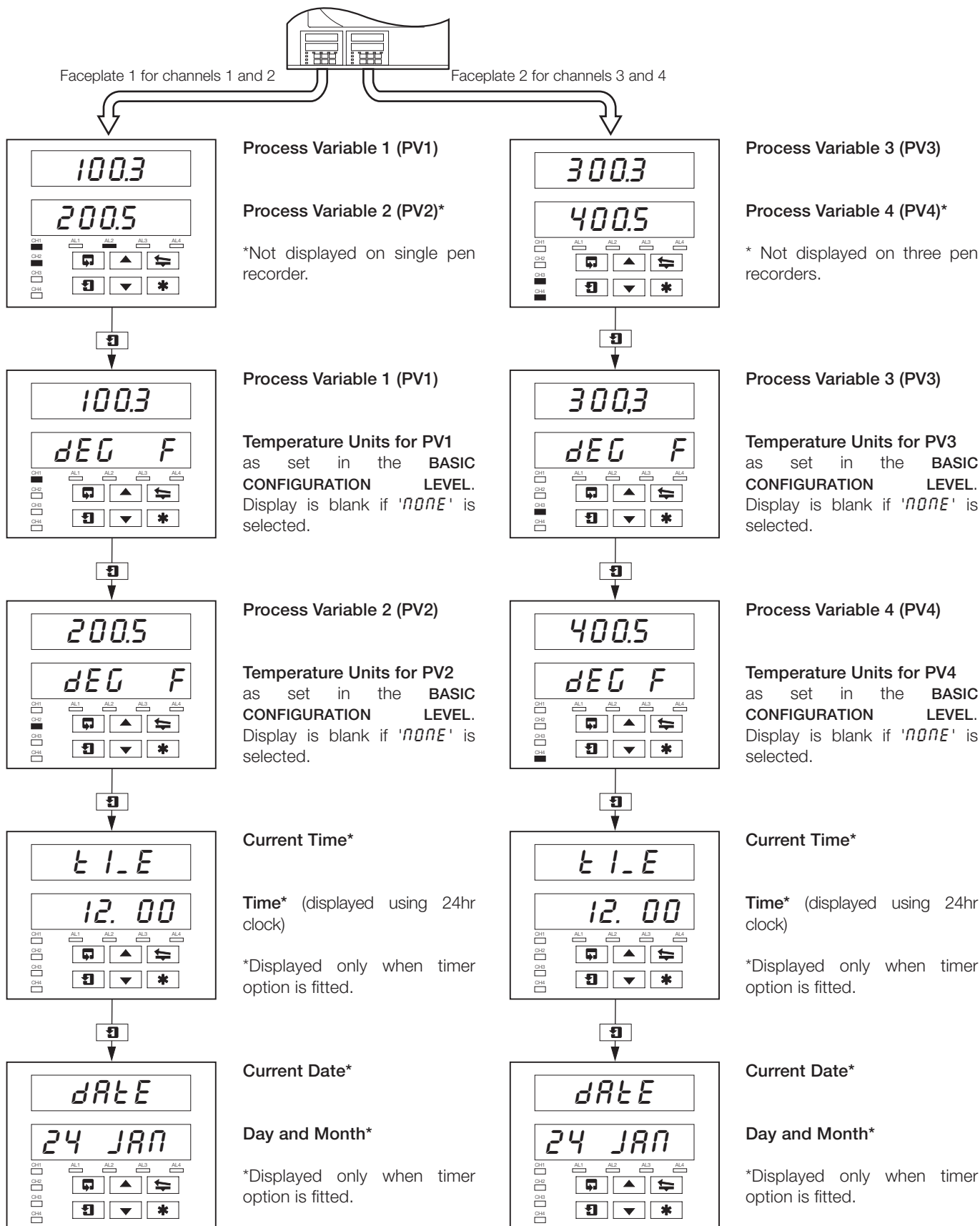

4.3 Alarm Acknowledge Page

4.3.1 Alarm Indications – Fig. 4.3

The definitions for alarm states (on, off or flashing) are detailed in Fig. 4.3.

4.3.2 Acknowledging Alarms

Note. Channel 1 and 2 alarms can be acknowledged only from faceplate 1. Channel 3 and 4 alarms (if applicable) can be acknowledged only from faceplate 2.

Unacknowledged alarms can be acknowledged from the faceplate controls on the front panel in two ways:

In the **OPERATING LEVEL** – by pressing the **[*]** key at any frame (providing the key is programmed for this function – see Section 4.1 in the **Programming Manual**).

In the **Alarm Acknowledge Page** – by pressing the **[▲]** key – see Section 4.3.3 following.

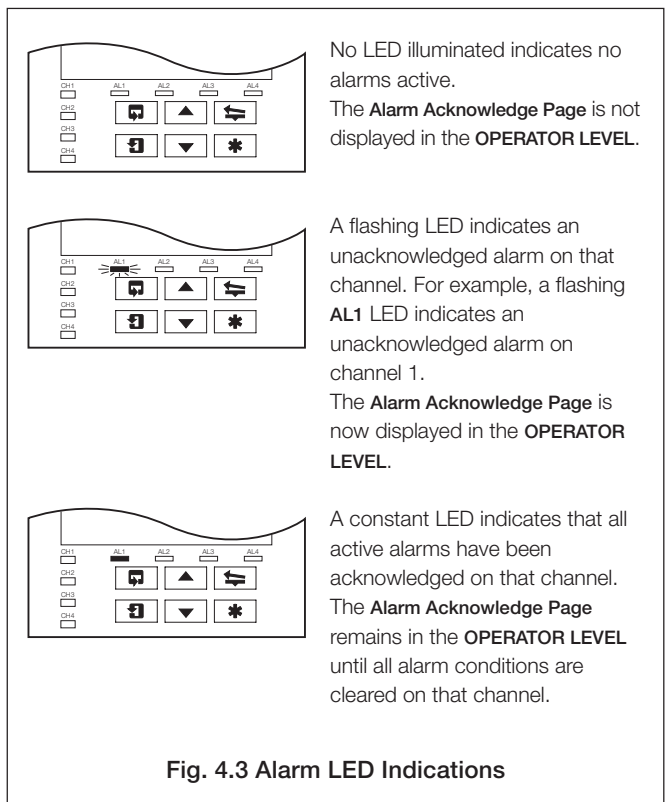

4.3.3 Using the Alarm Acknowledge Page

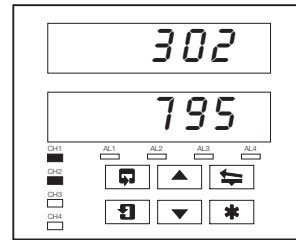

No Alarm Active
No LED indicators illuminated.

Alarm Activated

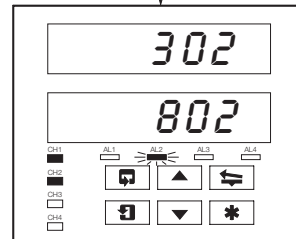

Alarm Active
AL2 LED indicator flashing, indicating active alarm on channel 2.

Use **[☐]** key to go to top of Alarm Acknowledge Page.

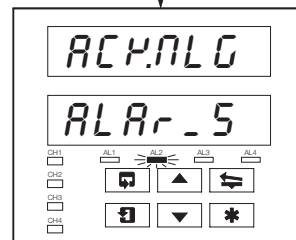

Alarm Acknowledge Page
Use **[☐]** key to advance to next frame

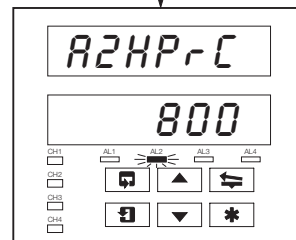

Alarm Identity
Upper display: shows the alarm identity and type.

Lower Display: shows the trip level of the alarm identified in the upper display.

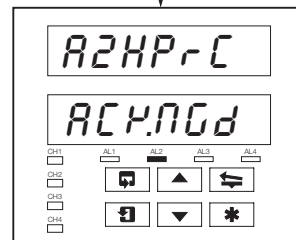

Acknowledge Alarm
Use **[▲]** key to acknowledge the alarm (see). When the alarm is acknowledged, 'ACK' is displayed and a constant LED indicates the acknowledged alarm.

If there are more active alarms on channel 2 the LED continues to flash until all alarms for that channel have been acknowledged.

Note. The **[*]** key or a digital input can also be used to acknowledge alarm, if programmed.

4.4 Totals Page Displays

This page is omitted from both faceplates if the **Totalizer Option** is not fitted. The page is also omitted from faceplate 1 if both Totals 1 and 2 are set to *OFF* and from faceplate 2 if both Totals 3 and 4 are set to *OFF* – refer to the **Set Up Totals Page** in the **Advanced Software Options Manual**.

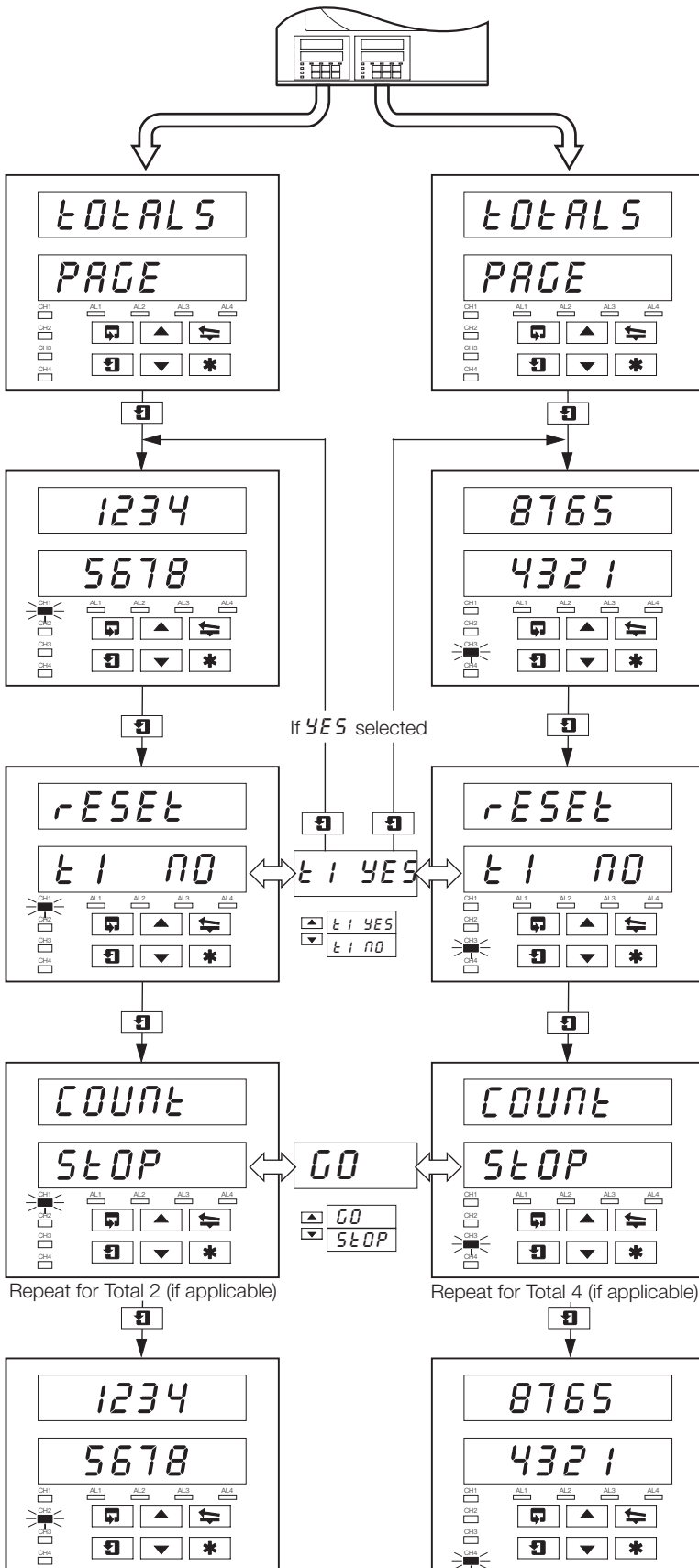

Front Panel (Batch) Flow Total 1 (3)

The batch flow total is calculated from process variable 1 (3). The flow total can be reset if **Reset Enable** in **Set Up Totals Page** is set to *'ENbL -Y'*.

The flashing channel LED indicates the flow total displayed.

For example, a flashing channel 1 LED indicates **Flow Total 1** parameters displayed.

Counter Reset

The Front (Batch) Flow Total can be reset to the **Preset Value** in **Set Up Totals Page** if required.

Select *'t 1 YES'* to reset the counter (*'t 1'* indicates **Flow Total 1**).

Note. If the Counter Reset is disabled in **Set Up Totals Page**, the counter reset frame is omitted.

Counter Stop/Go

Select *'GO'* to start the counter or *'STOP'* to stop it.

Note. If the Counter Stop/Go is disabled in **Set Up Totals Page**, the frame can be viewed but not altered. If a digital signal is assigned to the **Totalizer Stop/Go**, an active digital signal sets the counter to *GO* and the Counter cannot be stopped from the front panel.

Front Panel (Batch) Flow Total 2 (4)

Repeat the above procedure for **Flow Total 2** (4).

Note. The number of totalizers is dependent on the number of pens fitted to the instrument e.g. a 3 pen instrument has 3 totalizers.

4.5 Access to Configuration Levels

A security system is used to prevent tampering with the programmed parameters by utilizing a password giving access to all programming pages – refer to the **Programming Manual**.

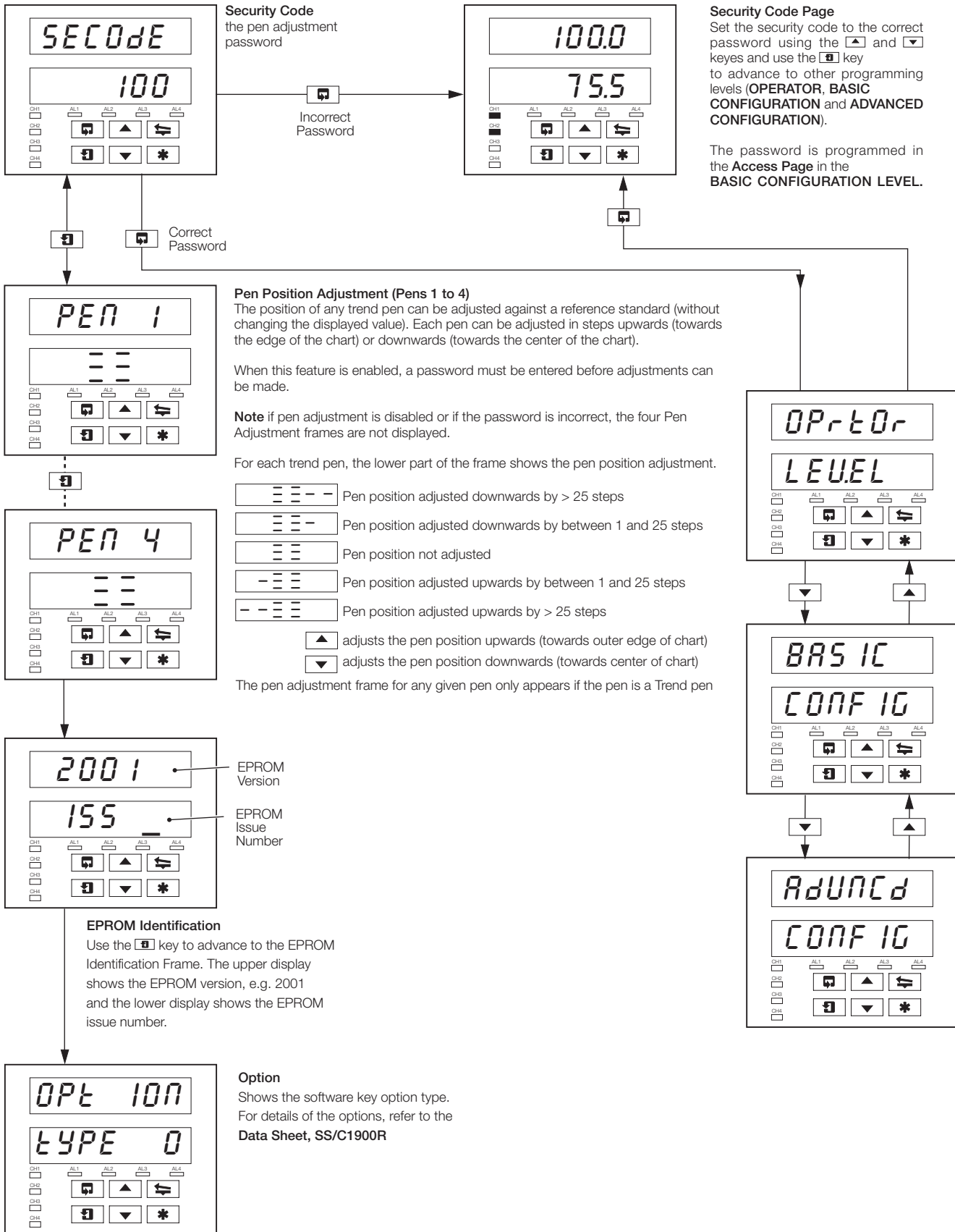

5 SIMPLE FAULT FINDING

Symptom	Possible Cause	Action
Does not power up	<ul style="list-style-type: none"> a) Internal fuse (if fitted) is blown b) Internal power switch (if fitted) is OFF c) Power supply connections are incorrect 	<ul style="list-style-type: none"> a) Check wiring, rectify fault and replace fuse b) Turn power switch ON c) Check connections
Chart does not appear to move	<ul style="list-style-type: none"> a) Very slow chart speed selected b) Chart stop function enabled 	<ul style="list-style-type: none"> a) Select required chart speed in Set Up Chart Page b) De-activate source being used to stop chart – see Set Up Chart Page
Pens in recording position but do not drop onto paper	Chart stop function enabled	De-activate source used to stop chart – see Set Up Chart Page
Red pen does not move beyond 94% position on chart	When real time event pen is fitted the red pen cannot go beyond 94% to prevent pens clashing	Use chart range which prevents the need to go beyond 94% of maximum on chart
Pen lift switch on front panel does not work	Pen lift switch is disabled	Enable pen-lift switch in Set Up Chart Page
Pens do not remain lifted when pen lift key is used	Auto pen drop feature is enabled	Disable auto pen drop in Set Up Chart Page if this is not required
Analog inputs are slow to respond	A large filter time has is set	Set digital filter value to give required response in Set Up Inputs
Time or date incorrect	Not set for correct local time	Set correct time and date in Set Up Clock Page – refer to Advanced Software Manual
Totalizers cannot be set to STOP or GO	Operator STOP/GO selection is not enabled in the OPERATOR LEVEL	Enable counter STOP/GO in the Set Up Totals Page
Totalizer cannot be set to STOP	Digital signal assigned to the total STOP/GO function is active	De-activate digital signal assigned to total STOP/GO function
External relays connected to relays in instrument fail to de-energize	Arc suppression capacitors are provided across the relay contacts and capacitor leakage current may be sufficient to prevent an external relay from de-energizing	Remove the arc suppression components – IC4 and IC5 on mainboard IC6 and IC7 on standard I/O and analog relay IC3 to IC10 on 4 relay module

6 SPARES LIST

Item	Part No.
Pen Capsules (pack of 3)	
Black	C1900/0119
Blue	C1900/0120
Red	C1900/0121
Green	C1900/0122
Violet*	C1900/0123

Pen Arm Assemblies

ER/C Type Chart (J or R in Code Number) – Standard Pen	C1900/0076
ER/C Type Chart (J or R in Code Number) – Event Pen	C1900/0078
PX105 and PXR105 Type Chart (K or S in Code Number) – Standard Pen	C1900/0075
PX105 and PXR105 Type Chart (K or S in Code Number) – Event Pen	C1900/0077

Fuses

24V	B11071 (4A)
115V	B11070 (1A)
230V	B11069 (500mA)

*True time line event option only.

NOTES

Products and customer support

Automation Systems

For the following industries:

- Chemical & Pharmaceutical
- Food & Beverage
- Manufacturing
- Metals and Minerals
- Oil, Gas & Petrochemical
- Pulp and Paper

Drives and Motors

- AC and DC Drives, AC and DC Machines, AC Motors to 1kV
- Drive Systems
- Force Measurement
- Servo Drives

Controllers & Recorders

- Single and Multi-loop Controllers
- Circular Chart and Strip Chart Recorders
- Paperless Recorders
- Process Indicators

Flexible Automation

- Industrial Robots and Robot Systems

Flow Measurement

- Electromagnetic Flowmeters
- Mass Flowmeters
- Turbine Flowmeters
- Wedge Flow Elements

Marine Systems & Turbochargers

- Electrical Systems
- Marine Equipment
- Offshore Retrofit and Refurbishment

Process Analytics

- Process Gas Analysis
- Systems Integration

Transmitters

- Pressure
- Temperature
- Level
- Interface Modules

Valves, Actuators and Positioners

- Control Valves
- Actuators
- Positioners

Water, Gas & Industrial Analytics Instrumentation

- pH, Conductivity and Dissolved Oxygen Transmitters and Sensors
- Ammonia, Nitrate, Phosphate, Silica, Sodium, Chloride, Fluoride, Dissolved Oxygen and Hydrazine Analyzers
- Zirconia Oxygen Analyzers, Katharometers, Hydrogen Purity and Purge-gas Monitors, Thermal Conductivity

Customer support

We provide a comprehensive after sales service via a Worldwide Service Organization. Contact one of the following offices for details on your nearest Service and Repair Centre.

UK

ABB Limited
Tel: +44 (0)1453 826661
Fax: +44 (0)1453 829671

USA

ABB Inc.
Tel: +1 215 674 6000
Fax: +1 215 674 7183

Client Warranty

Prior to installation, the equipment referred to in this manual must be stored in a clean, dry environment, in accordance with the Company's published specification. Periodic checks must be made on the equipment's condition. In the event of a failure under warranty, the following documentation must be provided as substantiation:

- A listing evidencing process operation and alarm logs at time of failure.
- Copies of all storage, installation, operating and maintenance records relating to the alleged faulty unit.

Contact us

To find your local ABB contact visit:

www.abb.com/contacts

For more product information visit:

www.abb.com

Note

We reserve the right to make technical changes or modify the contents of this document without prior notice. With regard to purchase orders, the agreed particulars shall prevail. ABB does not accept any responsibility whatsoever for potential errors or possible lack of information in this document.

We reserve all rights in this document and in the subject matter and illustrations contained therein. Any reproduction, disclosure to third parties or utilization of its contents in whole or in parts - is forbidden without prior written consent of ABB.

Copyright© 2010 ABB

All rights reserved

IM/C1900-0GR Rev. J 08.2010