

9376 MTL Trunk Surge Module

Introduction

The 9376-SP Trunk Surge module is designed to protect the 9370-FB range of Fieldbus Barrier System from voltage and current surges that could occur on the trunk wiring, and must be used only with this equipment.

See the 9376-SP technical datasheet for full product details.

It is a 4-pin module that plugs into the upper end face of the Trunk Terminator Assembly (TTA) and is provided with pin connectors that will prevent an ignition spark when the module is installed or removed.

The 9376-SP module may be installed or removed without isolating the trunk power.

READ SAFETY INFORMATION OVERLEAF

Installing a module

Remove the module from any packaging provided. Do not use, or attempt to repair, a module that has any of the pins on its underside bent or damaged, because this might affect its safety and invalidate the certification.

Orientate the module so that the smaller front clip is facing the user, then:

- lower the module so that the safety retaining clip (5) on the TTA housing fits into the loop (6) on the module,
- locate the terminal pins into their contact sockets on the TTA housing, and push the module home until front and rear retaining clips are engaged.

Removing a module

Removal is a two-step process that first breaks the electrical connection, followed by the physical removal of the module from the TTA.

- Press the clip at the rear of the module (1) and lift the rear of the module (2) until the clip disengages.
- Press the front clip (3) and withdraw the module from its socket (4) until it is stopped by the safety retaining clip (5).
- Press against the safety clip enough to release it and pull the module straight out from the TTA body without rotating it.

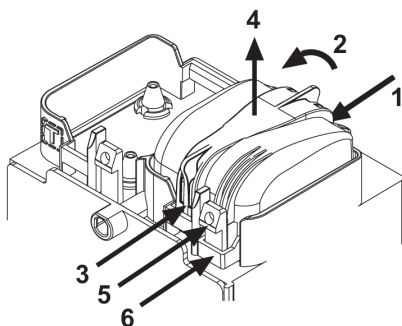
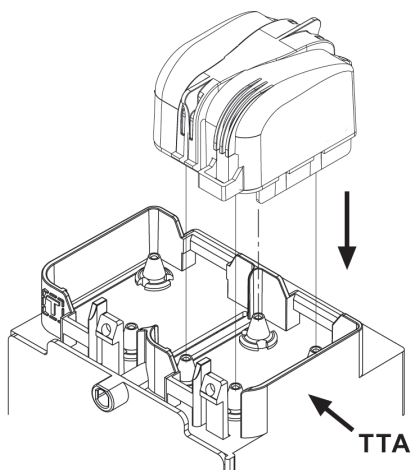

MTL trunk surge module

January 2017

ATEX and IECEx Safety Instructions for 9376-SP Trunk Surge Module

The following information is in accordance with the Essential Health and Safety Requirements (Annex II) of the EU Directive 2014/34/EU [the ATEX Directive - safety of apparatus] and is provided for those locations where such requirements are applicable.

General

- a) This module must only be installed, operated and maintained by competent personnel. Such personnel shall have undergone training, which included instruction on the various types of protection and installation practices, the relevant rules and regulations, and on the general principles of area classification. Appropriate refresher training shall be given on a regular basis. [See clause 4.2 of EN 60079-17].
- b) This module has been designed to provide protection against all the relevant additional hazards referred to in Annex II of the directive, such as those in clause 1.2.7.
- c) This module has been designed to meet the requirements of EN 60079-0, EN 60079-1, EN 60079-7, EN 60079-18.

Installation

- d) The installation must comply with the appropriate European, national and local regulations, which may include reference to the IEC code of practice IEC 60079-14. In addition, particular industries or end users may have specific requirements relating to the safety of their installations and these requirements should also be met. For the majority of installations the Directive 1999/92/EC [the ATEX Directive - safety of installations] is also applicable.
- e) This module can be mounted in a Safe area or a Zone 2 or Zone 1 hazardous area. When mounted in a Zone 2 or Zone 1 location the module must be provided with an enclosure, which offers an additional degree of protection appropriate to the area classification.
- f) Unless already protected by design, this module must be protected by a suitable enclosure against:
 - i) mechanical and thermal stresses in excess of those noted in the certification documentation and the product specification.
 - ii) aggressive substances, excessive dust, moisture and other contaminants.

Read also the Schedule of Limitations (below) for any additional or more specific information.

Schedule of Limitations

- 1) The 9376-SP Trunk Surge Protector must be housed in an appropriately certified Ex e enclosure.
- 2) The 9376-SP Trunk Surge Protector must plug into equipment that uses the socket part of the connector covered by certificate TUV09ATEX555354U.
- 3) Due to the presence of transient protection components between the fieldbus and earth connections, the 9376-SP Trunk Surge Protector will not withstand a 500V a.c. dielectric strength test. This must be taken into account during installation.
- 4) The ambient temperature must not exceed +75°C.
- 5) The 9376-SP Trunk Surge Protector shall only be powered from supplies conforming to IEC 61158.
- 6) The 9376-SP Trunk Surge Protector shall only be connected into equipment that causes the secondary latching connector to limit movement before the live-demateable connector plug and socket metal parts separate by over 1.9mm.

Inspection and maintenance

Inspection and maintenance should be carried out in accordance with European, national and local regulations which may refer to the IEC standard IEC 60079-17. In addition specific industries or end users may have specific requirements which should also be met.

Repair

This module cannot be repaired by the user and must be replaced with an equivalent certified product.

Marking

Each module is marked in compliance with the above Directive and CE marked with the Notified Body Identification Number.

This information applies to modules manufactured during or after the year 2010.



Powering Business Worldwide

Eaton Electric Limited,
Great Marlings, Butterfield, Luton
Beds, LU2 8DL, UK
Tel: +44 (0)1582 723633 Fax: +44 (0)1582 422283
E-mail: mtlenquiry@eaton.com
www.mtl-inst.com

© 2017 Eaton
All Rights Reserved
Publication No. INS9376 Rev 2 170117
January 2017

EUROPE (EMEA):
+44 (0)1582 723633
mtlenquiry@eaton.com

THE AMERICAS:
+1 800 835 7075
mtl-us-info@eaton.com

ASIA-PACIFIC:
+65 6 645 9888
sales.mtising@eaton.com

The given data is only intended as a product description and should not be regarded as a legal warranty of properties or guarantee. In the interest of further technical developments, we reserve the right to make design changes.