

Rosemount™ 3308 Series Wireless Guided Wave Radar, 3308A

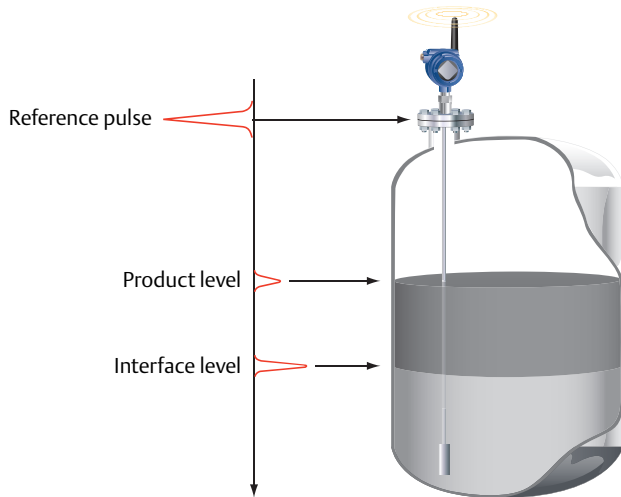

- World's first true wireless Guided Wave Radar based on field proven, market leading technologies
- Accurate, direct level and interface measurements virtually unaffected by process conditions
- Fast and simple commissioning with self-organizing wireless network, intuitive user interface and cut-to-fit probes
- Minimized maintenance with no wires, no moving parts, no re-calibration, long battery life and advanced diagnostics for better process insight

Introduction



Guided wave radar

The Rosemount 3308 Series measurement is based on the Time Domain Reflectometry (TDR) principle. Low power nano-second-pulses are guided along a probe submerged in the process media. When a pulse reaches the surface of the material it is measuring, part of the energy is reflected back to the transmitter, and the time difference between the generated and reflected pulse is converted into a distance from which the total level or interface level is calculated (see left).

The reflectivity of the product, its dielectric constant, is a key parameter for measurement performance. A high dielectric constant of the media gives better reflection and a longer measuring range.

With innovative technologies inherited from other market leading Rosemount guided wave radars, Rosemount 3308 Series delivers reliable measurements without compromising a long battery life.

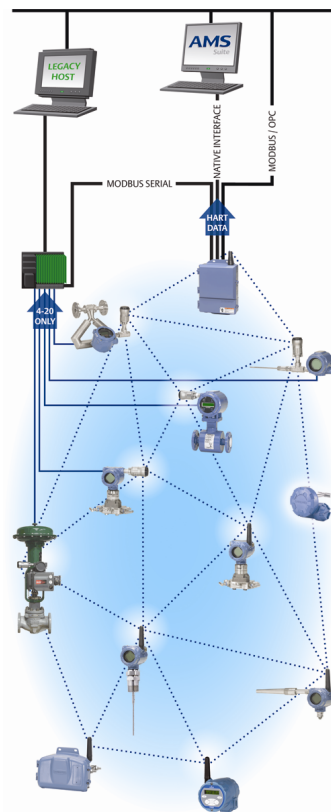

Emerson™ Wireless

Emerson Wireless is a self-organizing network solution. Wireless field instruments send data to a Gateway, directly or routed through any of the wireless devices in the network. Multiple communication paths are managed and analyzed in parallel to assure optimal communication and sustained network reliability even if obstructions are introduced.

Gateways interface with existing host systems using industry standard protocols, and native integration into DeltaV™ and Ovation™ is transparent and seamless.

Interference from other radios, Wi-Fi®, and EMC sources is avoided through Time Synchronized Channel Hopping and Direct Sequence Spread Spectrum (DSSS). Also, a layered security implementing industry standard Encryption, Authentication, Verification, Anti-Jamming, and Key Management ensures that data transmissions are secure and received only by the Gateway.

The Rosemount 3308 Series is a member of the Emerson Wireless portfolio, whose wireless network experience totals billions of operating hours, hundreds of thousands field devices, and tens of thousands of networks around the world.

Contents

Ordering Information	4	Product Certifications	29
Specifications	14	Dimensional Drawings	32

Application examples

The Rosemount 3308 Series Transmitter is suited for aggregate (total) level measurements on a wide range of liquids, semi-liquids, and liquid/liquid interfaces.

The quick and easy installation of true wireless transmitters makes the Rosemount 3308 Series an ideal solution to automate measurements in remote locations or where existing wiring is limited. Moreover, the reliable and accurate nature of guided wave radar technology offers a versatile solution that is virtually unaffected by process conditions such as temperature, pressure, vapor gas mixtures, density, turbulence, bubbling/boiling, varying dielectric media, pH, and viscosity.

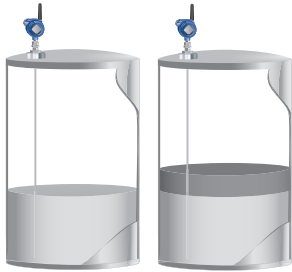

Storage and buffer tanks

The Rosemount 3308 Series Transmitter is ideal for storage or buffer tanks for almost any liquid, such as oil, gas condensate, water, or chemicals.

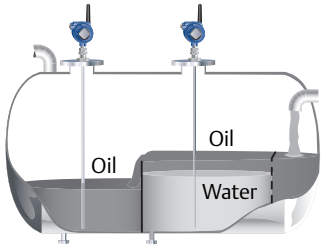

Low pressure separators

The Rosemount 3308 Series Transmitter can measure both level and interface level, such as for separator applications.

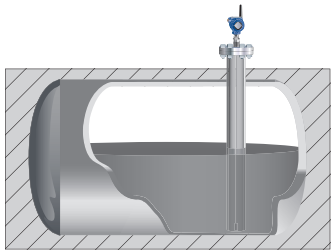

Waste tanks and sump pits

The Rosemount 3308 Series Transmitter is also a good choice for waste tanks and underground tanks, such as sump pits.

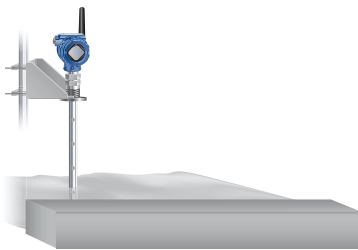

Open applications—ponds, basins, sumps

The Rosemount 3308 Series Transmitter can be installed in open air to measure liquids not contained in a tank.



Chamber applications

The Rosemount 3308 Series Transmitter is a good choice for both chamber and pipe installations.

Ordering Information



Rosemount 3308 Series Guided Wave Radar Level Transmitters are versatile and easy-to-use with field proven, market leading technologies. Characteristics include:

- Intrinsically Safe
- Long battery life
- IEC 62591 (*WirelessHART*[®]) Communication
- Compatible with AMS Device Manager and AMS Wireless Configurator packages for easy commissioning and troubleshooting

Additional Information

Specifications: [page 14](#)

Interface Measurement: [page 21](#)

Mechanical Considerations: [page 26](#)

Chamber/Pipe Installations: [page 27](#)

Certifications: [page 29](#)

Dimensional Drawings: [page 32](#)

Specification and selection of product materials, options, or components must be made by the purchaser of the equipment. See [page 23](#) for more information on Material Selection.

Table 1. Rosemount 3308 Series Level and/or Interface Measurements in Liquids Ordering Information

The starred offerings (★) represent the most common options and should be selected for best delivery. The non-starred offerings are subject to additional delivery lead time.

Model	Product description		
3308A	Guided Wave Radar Level Transmitter		★
Profile		Reference accuracy	
U ⁽¹⁾⁽²⁾	High Performance	±0.12 in. (±3 mm)	★
S	Standard	±0.25 in. (±6 mm)	★
Signal output (see page 19 for details)			
X	Wireless		★
Measurement type (see page 21)			
2	Level and Interface Transmitter		★
1	Level or Interface Transmitter (Interface available for fully submerged probe)		
Housing			
D1	Wireless Dual Compartment Housing, Aluminum (with plugged ½-14 NPT conduits)		★
E1	Wireless Dual Compartment Housing, Stainless steel (with plugged ½-14 NPT conduits)		★
Hazardous locations certifications (see page 29-31)			
I1	ATEX Intrinsic Safety		★
I2	INMETRO Intrinsic Safety		★
I3	NEPSI Intrinsic Safety		★

Table 1. Rosemount 3308 Series Level and/or Interface Measurements in Liquids Ordering Information

The starred offerings (★) represent the most common options and should be selected for best delivery. The non-starred offerings are subject to additional delivery lead time.

I4	TIIS Intrinsic Safety		★
I5	FM Intrinsically Safe		★
I6	Canadian Intrinsically Safe		★
I7	IECEX Intrinsic Safety		★
IM	Technical Regulations Customs Union (EAC) Intrinsic Safety		★
KD	ATEX and Canadian Intrinsic Safety		
KE	FM and Canadian Intrinsically Safe		
KF	ATEX and FM Intrinsic Safety		
NA	No Hazardous Locations Certifications		
Operating temperature and pressure (see page 20)			
S	- 15 psig (-1bar) to 580 psig (40 bar) @ 302 °F (150 °C)		★
Material of construction; process connection/probe			Probe type
1	316L SST (EN 1.4404)	All	★
2	Alloy C-276 (UNS N10276). With plate design if flanged version.	3A, 3B, 4A, 4B, and 5A	
3	Alloy 400 (UNS N04400). With plate design if flanged version.	3A, 3B, 4A, 4B, and 5A	
7	PTFE covered probe and flange. With plate design.	4A and 5A	
8	PTFE covered probe	4A and 5A	
H	Alloy C-276 (UNS N10276) process connection, flange, and probe	3A, 3B, 4A, 4B, and 5A	
D	Duplex 2205 (UNS S31803) process connection, flange, and probe	4B and 5A	
Sealing O-ring material (see page 20)			
V	Viton® Fluoroelastomer		★
E	Ethylene Propylene (EPDM)		★
K	Kalrez® 6375 Perfluoroelastomer		★
B	Nitrile Butadiene (NBR)		★
Process connection size (see Table 2 and Table 3 on page 10 for availability)			Process connection type
5	1½-in.	Thread/Tri Clamp	★
2	2-in./DN50/50A	NPT Thread/Flange/Tri Clamp	★
3	3-in./DN80/80A	Flange/Tri Clamp	★
4	4-in./DN100/100A	Flange/Tri Clamp	★
P	Proprietary Flanges	Proprietary Flange	★
1	1-in.	Thread	
6	6-in./DN150/150A	Flange	
8	8-in./DN200/200A	Flange	

Table 1. Rosemount 3308 Series Level and/or Interface Measurements in Liquids Ordering Information

The starred offerings (★) represent the most common options and should be selected for best delivery. The non-starred offerings are subject to additional delivery lead time.

Process connection rating (see Table 2 and Table 3 on page 10 for availability)				
NN	For use with non-flange process connection type		★	
ASME rating				
AA	ASME B16.5 Class 150 Flange		★	
AB	ASME B16.5 Class 300 Flange		★	
EN rating				
DA	EN1092-1 PN16 Flange		★	
DB	EN1092-1 PN40 Flange		★	
JIS rating				
JA	JIS B2220 10K Flange		★	
JB	JIS B2220 20K Flange		★	
Proprietary				
PF	Proprietary Flange		★	
Process connection type (see Table 2 and Table 3 on page 10 for availability)				
Thread				
N	NPT thread		★	
G	BSPP (G) thread		★	
Flange faces				
F	Flat Face (FF) Flange, available for EN flanges		★	
R	Raised Face (RF) Flange, available for ASME and JIS flanges		★	
Proprietary flanges (see page 39 for dimensions)				
M	Masoneilan™-Proprietary, 316 SST Torque Tube Flange, 316L		★	
P	Fisher™-Proprietary, 316 SST, (for 249B and 259B cages) Torque Tube Flange, 316L		★	
Q	Fisher-Proprietary, 316 SST, (for 249C cages) Torque Tube Flange, 316L		★	
Tri Clamp				
C	Tri Clamp			
Probe type	Process connection type	Probe lengths		
3B	Coaxial, perforated. For level and interface measurement.	Flange/1-, 1½-, 2-in. Thread	Min.:1 ft. 4 in. (0.4 m) Max.: 19 ft. 8 in. (6 m)	★
4A	Rigid Single Lead (d=0.3"/8 mm)	Flange/1-, 1½-, 2-in. Thread/Tri Clamp	Min.:1 ft. 4 in. (0.4 m) ⁽³⁾ Max.: 9 ft. 10 in. (3 m)	★
4B	Rigid Single Lead (d=0.5"/13 mm)	Flange/1½-, 2-in. Thread/Tri Clamp	Min.:1 ft. 4 in. (0.4 m) Max.: 19 ft. 8 in. (6 m)	★
5A	Flexible Single Lead (d=0.16"/4 mm). Refer to page 8 to specify weight or chuck.	Flange/1-, 1½-, 2-in. Thread/Tri Clamp	Min.:3 ft. 4 in. (1 m) ⁽³⁾ Max.: 55 ft. 9 in. (17 m)	★

Table 1. Rosemount 3308 Series Level and/or Interface Measurements in Liquids Ordering Information

The starred offerings (★) represent the most common options and should be selected for best delivery. The non-starred offerings are subject to additional delivery lead time.

2A	Flexible Twin Lead with weight	Flange/1½-, 2-in. Thread	Min.: 3 ft. 4 in. (1 m) Max.: 55 ft. 9 in. (17 m)	
3A ⁽⁴⁾	Coaxial (for level measurement)	Flange/1-, 1½-, 2-in. Thread	Min.: 1 ft. 4 in. (0.4 m) Max.: 19 ft. 8 in. (6 m)	
4S	Segmented Rigid Single Lead (d=0.5"/13 mm)	Flange/1½-, 2-in. Thread	Min.: 1 ft. 4 in. (0.4 m) Max.: 32 ft. 9 in. (10 m)	
Probe length units (see page 23 for total probe length)				
E	English (feet, inches)			★
M	Metric (meters, centimeters)			★
Probe length (feet/meters)				
XXX	0-55 feet or 0-17 meters			★
Probe length (inches/centimeters)				
XX	0-11 inches or 0-99 Centimeters			★
Update rate, operating frequency and protocol				
WA3	User Configurable Update Rate, 2.4 GHz, IEC 62591 (<i>WirelessHART</i>)			★
Omnidirectional wireless antenna and SmartPower™ solutions (see page 19 for functional specification)				
WK1	External Antenna, Adapter for Intrinsically Safe Black Power Module (Power Module Sold Separately)			★
WN1	High Gain, Remote Antenna (see page 38 for dimensions), Adapter for Intrinsically Safe Black Power Module (Power Module Sold Separately)			★
Note: Black Power Module must be shipped separately; order Model 701PBKKF (part number 00753-9220-0001).				

Options (include with selected model number)

Display				
M5	LCD Display (see page 19)			★
Hydrostatic testing				
P1	Hydrostatic Testing, including certificate			★
Factory configuration				
C1	Factory Configuration per Configuration Data Sheet			★
Special quality assurance				
Q4	Calibration Data Certificate			★
Material traceability certification				
Q8 ⁽⁵⁾	Material Traceability Certification per EN 10204 3.1			★

Table 1. Rosemount 3308 Series Level and/or Interface Measurements in Liquids Ordering Information

The starred offerings (★) represent the most common options and should be selected for best delivery. The non-starred offerings are subject to additional delivery lead time.

Welding procedure qualification/specification		
Q66	Welding Procedure Qualification Record Documentation	
Q67	Welder Performance Qualification Record	
Q68	Welding Procedure Specification	
Special certifications		
QG	GOST Certification	
Materials certification		
Q15 ⁽⁶⁾	NACE® material recommendation per NACE MR0175/ISO 15156	★
Installation options		
LS	Long Stud for Flexible Single Lead Probes, 25 cm (10 in.) (for use in tall nozzles)	★
BR	Mounting Bracket for 1½-in. NPT Process Connection (see page 37)	
Weight and anchoring options for flexible single probes (see page 32 for dimensions)		
W1	Small Weight (for narrow tank openings less than 2 in. (50 mm)) (Required for PTFE covered probes)	★
W3	Heavy weight (for most applications)	★
W4	Chuck (to tie probe end to tank bottom)	★
W2	Short weight (when measuring close to the probe end)	
Weight assembly options for flexible single probes		
WU	Weight or chuck not mounted on the probe	★
Extended product warranty		
WR3	3-year limited warranty	★
WR5	5-year limited warranty	★
Plantweb™ diagnostic functionality		
DA1	HART® Diagnostics (see page 19)	★
Centering disc (see page 28 for dimensions and size recommendation)⁽⁷⁾		
S2 ⁽⁸⁾	2-in. Centering disc	★
S3 ⁽⁸⁾	3-in. Centering disc	★
S4 ⁽⁸⁾	4-in. Centering disc	★
P2	2-in. Centering disc PTFE	★
P3	3-in. Centering disc PTFE	★
P4	4-in. Centering disc PTFE	★
S6 ⁽⁸⁾	6-in. Centering disc	
S8 ⁽⁸⁾	8-in. Centering disc	

Table 1. Rosemount 3308 Series Level and/or Interface Measurements in Liquids Ordering Information

The starred offerings (★) represent the most common options and should be selected for best delivery. The non-starred offerings are subject to additional delivery lead time.

P6	6-in. Centering disc PTFE	
P8	8-in. Centering disc PTFE	
Assemble/consolidate to chamber (see page 27)		
XC	Consolidate to Chamber	★
Engineered solutions (see page 26)		
Pxxxx	Engineered Solutions beyond standard model codes. (Consult factory for details)	

1. The Rosemount 3308A with profile code U has two performance modes: Standard and High Performance (default). The performance mode may be reconfigured in field.
2. Available with hazardous locations certifications I1, I5, I6, and I7.
3. Minimum probe length is 4 ft. 11 in. (1.5 m) for PTFE covered probes (Material of Construction codes 7 and 8).
4. Requires model 3308Axx1.
5. Certificate includes all metallic pressure retaining wetted parts.
6. Available for Probe Type 3A, 3B, 4A, 4B, 4S, and PTFE-coated 5A.
7. Available for SST, Alloy C-276, Alloy 400, and Duplex 2205 probes, type 2A, 4A, 4B, 4S, and 5A. Not available with PTFE covered probes (Material of Construction codes 7 and 8).
8. Centering disc in same material as probe material of construction.

Table 2. Availability of Process Connections - Material of Construction Codes 1, 2, 3, 7, and 8 (Type vs. Size and Rating)

Process connection size	Process connection rating							
	Thread/Tri Clamp	ASME B16.5 flanges		EN1092-1 flanges		JIS B2220 flanges		Proprietary flanges ⁽¹⁾
		Class 150	Class 300	PN16	PN40	10K	20K	
1-in.	G ⁽²⁾ , N ⁽²⁾	N/A	N/A	N/A	N/A	N/A	N/A	N/A
1½-in.	C ⁽²⁾ , N ⁽³⁾ , G ⁽³⁾	N/A	N/A	N/A	N/A	N/A	N/A	N/A
2-in./DN50/50A	C ⁽²⁾ , N ⁽²⁾	R	R	F	F	R	R	N/A
3-in./DN80/80A	C ⁽²⁾	R	R	F	F	R	R	N/A
4-in./DN100/100A	C ⁽²⁾	R	R	F	F	R	R	N/A
6-in./DN150/150A	N/A	R	R	F	F	R	R	N/A
8-in./DN200/200A	N/A	R	R	F	F	R	R	N/A
Proprietary flanges	N/A	N/A	N/A	N/A	N/A	N/A	N/A	M, P, Q

- Only available with material of construction codes 1, 7, and 8.
- Only available with material of construction codes 1 and 8.
- Only available with material of construction codes 1, 2, 3, and 8.
C = Tri Clamp (process connection type code C)
F = Flat Face (process connection type code F)
G = BSPP (G) thread (process connection type code G)
M = Masoneilan (process connection type code M)
N = NPT thread (process connection type code N)
P = Fisher 249B/259B (process connection type code P)
Q = Fisher 249C (process connection type code Q)
R = Raised Face (process connection type code R)

Table 3. Availability of Process Connections - Material of Construction Codes H and D (Type vs. Size and Rating)

Process connection size	Process connection rating							
	Thread/Tri Clamp	ASME B16.5 flanges		EN1092-1 flanges		JIS B2220 flanges		Proprietary flanges
		Class 150	Class 300	PN16	PN40	10K	20K	
1-in.	N/A	N/A	N/A	N/A	N/A	N/A	N/A	N/A
1½-in.	G, N	N/A	N/A	N/A	N/A	N/A	N/A	N/A
2-in./DN50/50A	N/A	R	R	N/A	N/A	N/A	N/A	N/A
3-in./DN80/80A	N/A	R	R	N/A	N/A	N/A	N/A	N/A
4-in./DN100/100A	N/A	R	R	N/A	N/A	N/A	N/A	N/A
6-in./DN150/150A	N/A	R ⁽¹⁾	N/A	N/A	N/A	N/A	N/A	N/A
8-in./DN200/200A	N/A	N/A	N/A	N/A	N/A	N/A	N/A	N/A
Proprietary flanges	N/A	N/A	N/A	N/A	N/A	N/A	N/A	N/A

- Only available with material of construction code H.
G = BSPP (G) thread (process connection type code G)
N = NPT thread (process connection type code N)
R = Raised Face (process connection type code R)

Table 4. Accessories Ordering Information

The starred offerings (★) represent the most common options and should be selected for best delivery. The non-starred offerings are subject to additional delivery lead time.

Centering discs for rigid single lead probe (d=0.3"/8 mm)⁽¹⁾⁽²⁾		Outer diameter	
03300-1655-0001	Kit, 2-in. Centering Disc, SST	1.8 in. (45 mm)	★
03300-1655-0006	Kit, 2-in. Centering Disc, PTFE	1.8 in. (45 mm)	★
03300-1655-0002	Kit, 3-in. Centering Disc, SST	2.7 in. (68 mm)	★
03300-1655-0007	Kit, 3-in. Centering Disc, PTFE	2.7 in. (68 mm)	★
03300-1655-0003	Kit, 4-in. Centering Disc, SST	3.6 in. (92 mm)	★
03300-1655-0008	Kit, 4-in. Centering Disc, PTFE	3.6 in. (92 mm)	★
03300-1655-0004	Kit, 6-in. Centering Disc, SST	5.55 in. (141 mm)	
03300-1655-0009	Kit, 6-in. Centering Disc, PTFE	5.55 in. (141 mm)	
03300-1655-0005	Kit, 8-in. Centering Disc, SST	7.40 in. (188 mm)	
03300-1655-0010	Kit, 8-in. Centering Disc, PTFE	7.40 in. (188 mm)	
Centering discs for rigid single lead probe (d=0.5"/13 mm)⁽¹⁾⁽²⁾		Outer diameter	
03300-1655-0301	Kit, 2-in. Centering Disc, SST	1.8 in. (45 mm)	★
03300-1655-0306	Kit, 2-in. Centering Disc, PTFE	1.8 in. (45 mm)	★
03300-1655-0302	Kit, 3-in. Centering Disc, SST	2.7 in. (68 mm)	★
03300-1655-0307	Kit, 3-in. Centering Disc, PTFE	2.7 in. (68 mm)	★
03300-1655-0303	Kit, 4-in. Centering Disc, SST	3.6 in. (92 mm)	★
03300-1655-0308	Kit, 4-in. Centering Disc, PTFE	3.6 in. (92 mm)	★
03300-1655-0304	Kit, 6-in. Centering Disc, SST	5.55 in. (141 mm)	
03300-1655-0309	Kit, 6-in. Centering Disc, PTFE	5.55 in. (141 mm)	
03300-1655-0305	Kit, 8-in. Centering Disc, SST	7.40 in. (188 mm)	
03300-1655-0310	Kit, 8-in. Centering Disc, PTFE	7.40 in. (188 mm)	
Centering discs for flexible single/twin lead probes⁽¹⁾⁽²⁾		Outer diameter	
03300-1655-1001	Kit, 2-in. Centering disc, SST	1.8 in. (45 mm)	★
03300-1655-1006	Kit, 2-in. Centering disc, PTFE	1.8 in. (45 mm)	★
03300-1655-1002	Kit, 3-in. Centering disc, SST	2.7 in. (68 mm)	★
03300-1655-1007	Kit, 3-in. Centering disc, PTFE	2.7 in. (68 mm)	★
03300-1655-1003	Kit, 4-in. Centering disc, SST	3.6 in. (92 mm)	★
03300-1655-1008	Kit, 4-in. Centering disc, PTFE	3.6 in. (92 mm)	★
03300-1655-1004	Kit, 6-in. Centering disc, SST	5.55 in. (141 mm)	
03300-1655-1009	Kit, 6-in. Centering disc, PTFE	5.55 in. (141 mm)	
03300-1655-1005	Kit, 8-in. Centering disc, SST,	7.40 in. (188 mm)	
03300-1655-1010	Kit, 8-in. Centering disc, PTFE	7.40 in. (188 mm)	

Table 4. Accessories Ordering Information

The starred offerings (★) represent the most common options and should be selected for best delivery. The non-starred offerings are subject to additional delivery lead time.

Centering discs for mounting between segments (probe type 4S only)		Outer diameter	
03300-1656-1002	2-in. Centering Disc (1 pc), PTFE, Segmented Rigid Single Lead	1.8 in. (45 mm)	
03300-1656-1003	3-in. Centering Disc (1 pc), PTFE, Segmented Rigid Single Lead	2.7 in. (68 mm)	
03300-1656-1004	4-in. Centering Disc (1 pc), PTFE, Segmented Rigid Single Lead	3.6 in. (92 mm)	
03300-1656-1006	6-in. Centering Disc (1 pc), PTFE, Segmented Rigid Single Lead	5.55 in. (141 mm)	
03300-1656-1008	8-in. Centering Disc (1 pc), PTFE, Segmented Rigid Single Lead	7.40 in. (188 mm)	
03300-1656-3002	2-in. Centering Disc (3 pcs), PTFE, Segmented Rigid Single Lead	1.8 in. (45 mm)	
03300-1656-3003	3-in. Centering Disc (3 pcs), PTFE, Segmented Rigid Single Lead	2.7 in. (68 mm)	
03300-1656-3004	4-in. Centering Disc (3 pcs), PTFE, Segmented Rigid Single Lead	3.6 in. (92 mm)	
03300-1656-3006	6-in. Centering Disc (3 pcs), PTFE, Segmented Rigid Single Lead	5.55 in. (141 mm)	
03300-1656-3008	8-in. Centering Disc (3 pcs), PTFE, Segmented Rigid Single Lead	7.40 in. (188 mm)	
03300-1656-5002	2-in. Centering Disc (5 pcs), PTFE, Segmented Rigid Single Lead	1.8 in. (45 mm)	
03300-1656-5003	3-in. Centering Disc (5 pcs), PTFE, Segmented Rigid Single Lead	2.7 in. (68 mm)	
03300-1656-5004	4-in. Centering Disc (5 pcs), PTFE, Segmented Rigid Single Lead	3.6 in. (92 mm)	
03300-1656-5006	6-in. Centering Disc (5 pcs), PTFE, Segmented Rigid Single Lead	5.55 in. (141 mm)	
03300-1656-5008	8-in. Centering Disc (5 pcs), PTFE, Segmented Rigid Single Lead	7.40 in. (188 mm)	
Segmented rigid single lead probe spare part kit			
03300-0050-0001	15.2-in./385 mm Segment for Top connection (1 pc)		
03300-0050-0002	31.5-in./800 mm Segment (1 pc)		
03300-0050-0003	31.5-in./800 mm Segment (3 pcs)		
03300-0050-0004	31.5-in./800 mm Segment (5 pcs)		
03300-0050-0005	31.5-in./800 mm Segment (12 pcs)		
Vented flanges⁽³⁾			
03300-1812-0092	Fisher 249B/259B ⁽⁴⁾		
03300-1812-0093	Fisher 249C		
03300-1812-0091	Masoneilan		
Flushing connection rings			
DP0002-2111-S6	2-in. ANSI, ¼-in. NPT connection		
DP0002-3111-S6	3-in. ANSI, ¼-in. NPT connection		
DP0002-4111-S6	4-in. ANSI, ¼-in. NPT connection		
DP0002-5111-S6	DN50, ¼-in. NPT. connection		
DP0002-8111-S6	DN80, ¼-in. NPT. connection		

Table 4. Accessories Ordering Information

The starred offerings (★) represent the most common options and should be selected for best delivery. The non-starred offerings are subject to additional delivery lead time.

Other		
03300-7004-0001	MACTek® VIATOR® HART Modem and cables (RS232 connection)	★
03300-7004-0002	MACTek VIATOR HART Modem and cables (USB connection)	★

1. If a centering disc is required for a flanged probe, the centering disc can be ordered with options Sx or Px on [page 8](#) in the model code. If a centering disc is required for a threaded connection or as a spare part, it should be ordered using the item numbers listed in this table. Refer to [Table 20](#) for centering disc size recommendation for different pipe schedules.
2. To order a centering disc in a different material, consult the factory.
3. 1½-in. NPT threaded connection is required.
4. For pressure and temperature rating, see “[Fisher and Masoneilan](#)” on [page 20](#).

Specifications

Performance specifications

General

Reference conditions

- Probe: Flexible single lead
- Vessel: 4-in. pipe
- Measurement target: Water
- Temperature: 68 to 77 °F (20 to 25 °C)
- Relative humidity: 30-80%

Reference accuracy⁽¹⁾

- High performance (profile code U):
±0.12 in. (±3 mm), when distance < 33 ft. (10 m)
±0.03% of measured distance, when distance > 33 ft. (10 m)
- Standard (profile code S):

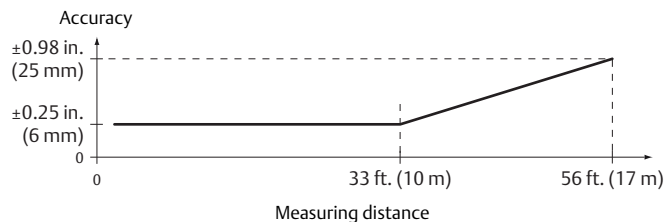

Ambient temperature effect

- High performance (profile code U): ±0.08 in. (±2 mm)/10 K
- Standard (profile code S): < 0.1% of measured distance per 10 K

Electromagnetic interference effect⁽²⁾

- External antenna (WK1 option): < ±0.25 in. (±6 mm)
- Remote (WN1 option): < ±0.2 in. (±5 mm)

Power module battery life⁽³⁾

- High performance: 5 years at one minute update rate
- Standard: 9 years at one minute update rate

Environment

Vibration resistance

No effect when tested per the requirements of IEC60770-1 (1999): High Vibration Level - field or pipeline (10-60 Hz 0.21 mm displacement peak amplitude / 60-2000 Hz 3g).

Electromagnetic compatibility

- Meets EN 61326-1:2013, EN 61326-2-3:2013, and NE21:2012 if installed in metallic vessels or still pipes.
- For optimal single lead probe performance in non-metallic tanks, the probe must be mounted with a metal flange, or screwed in to a metal sheet (d > 14 in./350 mm) if a threaded version is used. See [page 26](#) for more information.

Pressure Equipment Directive (PED)

Complies with 2014/68/EU article 4.3

Radio approvals

- Radio Equipment Directive (RED) 2014/53/EU
- Part 15 of the FCC Rules
- Industry Canada RSS 211

Interface measurement range

The maximum allowable upper product thickness/measuring range is primarily determined by the dielectric constants of the two liquids.

Typical applications include interfaces between oil/oil-like and water/water-like liquids, with a low (<3) dielectric constant for the upper product and a high (>20) dielectric constant for the lower product. For such applications, the maximum measuring range is limited by the length of the coaxial and rigid single lead probes.

For flexible probes, the maximum measuring range is reduced by the maximum upper product thickness, according to the diagram below. However, characteristics may vary between the different applications.

1. Refer to the IEC 60770-1 standard for a definition of radar specific performance parameters and if applicable corresponding test procedure.
2. Deviation through electromagnetic interference according to EN 61326.
3. Reference conditions are 70 °F (21 °C), and routing data for three additional network devices.

Figure 1. Maximum upper product thickness for flexible probes

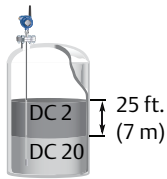
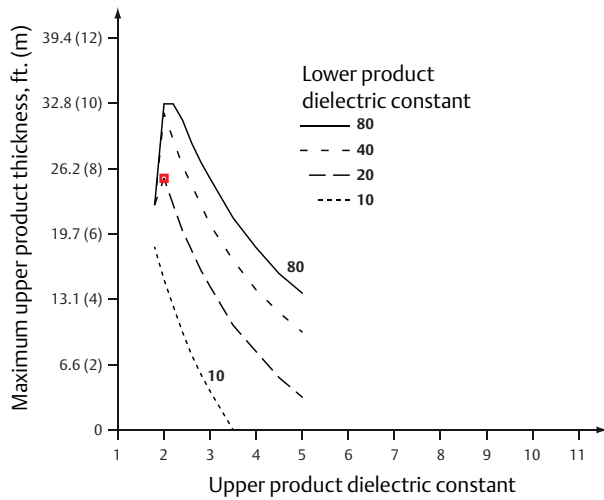

Example: With an upper product dielectric constant of 2, and a lower product dielectric constant of 20, the maximum upper product thickness is 25 ft. (7 m).

Table 5. Measuring Range and Minimum Dielectric Constant

Probe type	Maximum measuring range	Minimum dielectric constant ⁽¹⁾⁽²⁾
Flexible single lead	55.8 ft. (17 m)	2.0, when distance < 32.8 ft. (10 m) 10, when distance > 32.8 ft. (10 m)
Rigid single lead probe (0.3-in./8 mm)	9.8 ft. (3 m)	2.0
Rigid single lead probe (0.5-in./13 mm)	19.7 ft. (6 m)	2.0
Segmented rigid single lead	32.8 ft. (10 m)	2.0
Flexible twin lead	55.8 ft. (17 m)	2.0, when distance < 32.8 ft. (10 m) 10, when distance > 32.8 ft. (10 m)
Coaxial	19.7 ft. (6 m)	2.0

- Minimum Dielectric Constant may be lower than 2.0 if one or more of the following conditions apply:
 - Probe is installed in stilling well or chamber.
 - Maximum measuring range is not utilized.
 - Noise Threshold is manually adjusted to a lower level.
- For temperatures above 140 °F (60 °C) manual adjustment of noise threshold may be required for products with low dielectric constant at or close to maximum measuring range.

Table 6. Maximum Recommended Viscosity and Contamination/Build-up

Probe type	Maximum viscosity	Contamination/build-up
Single lead	8000 cP ⁽¹⁾⁽²⁾	Build-up allowed
Twin lead	1500 cP	Thin build-up allowed, but no bridging
Coaxial	500 cP	Not recommended

- Consult your local Emerson representative in the case of agitation/turbulence and high viscous products.
- For viscous or sticky applications, it is not recommended to use centering discs mounted along the probe.

Accuracy over measuring range

The measuring range depends on probe type, dielectric constant of the product and installation environment, and is limited by the Blind Zones at the very top and bottom of the probe. In the Blind Zones, the accuracy exceeds ± 1.18 in. (30 mm), and measurements may not be possible. Measurements close to the Blind Zones will have reduced accuracy.

The following conditions will impact the Blind Zones:

- If the single lead probes or twin probes are installed in a nozzle, the nozzle height shall be added to the specified Upper Blind Zone.
- The measuring range for the PTFE covered flexible single lead probe includes the weight when measuring on a high dielectric media.

Figure 2, Figure 3, Figure 4, and Figure 5 illustrate the accuracy over measuring range at reference condition using the Trim Near Zone function, with alternating probe types and varying dielectric constant of the product.

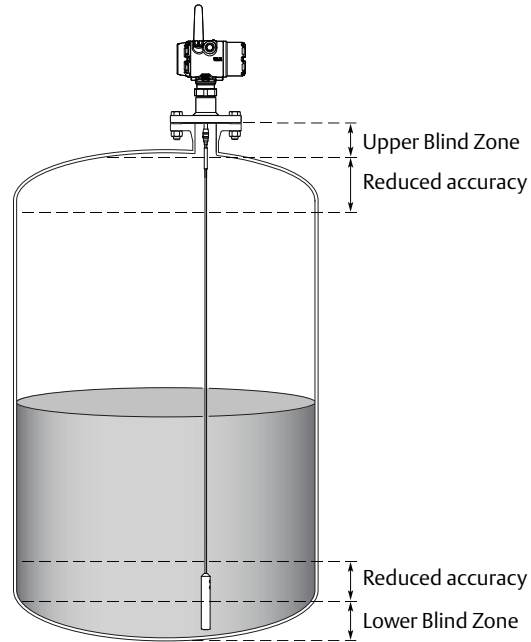

Note

Measurements may not be possible in the Blind Zones, and measurements close to the Blind Zones will have reduced accuracy. Therefore, the alarm points should be configured outside these zones.

Figure 2. Accuracy over Measuring Range for Flexible Single Lead Probe

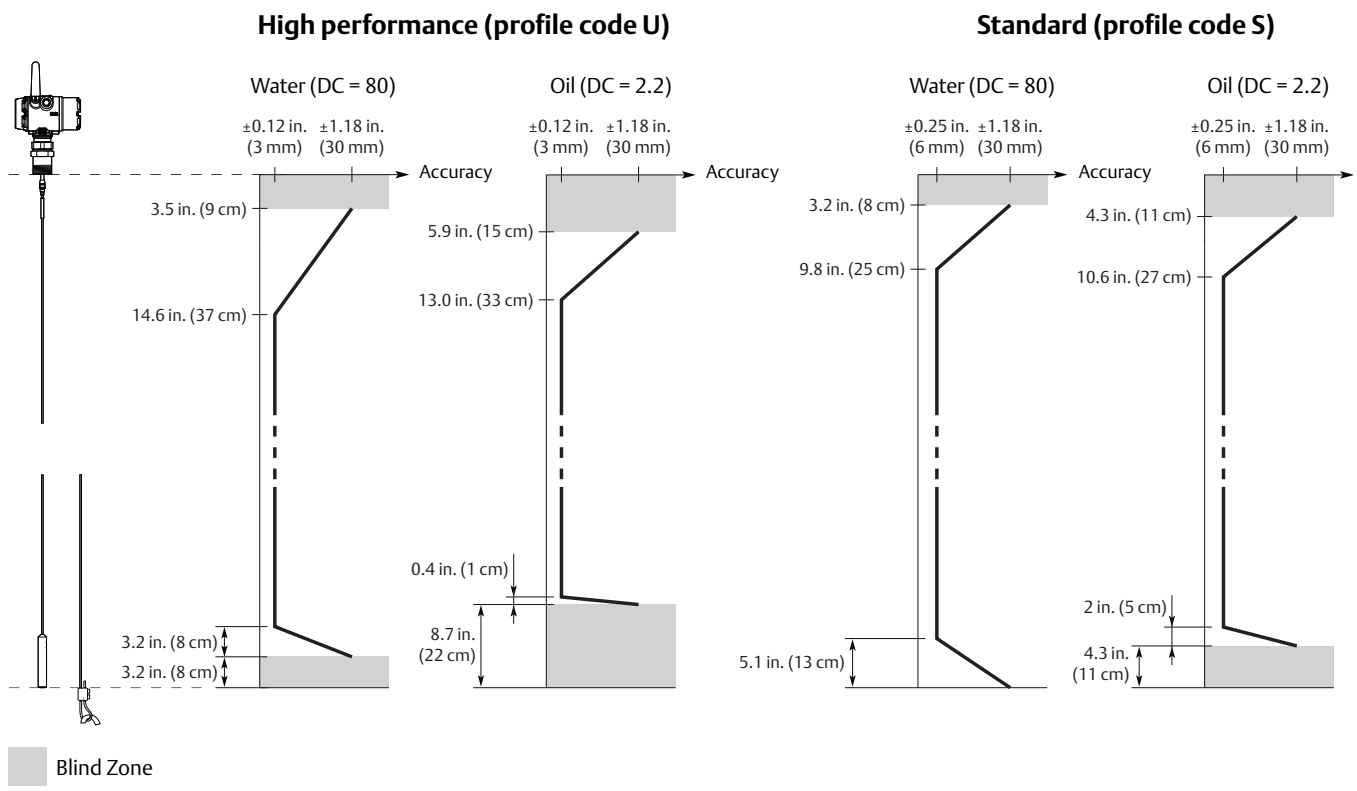

Figure 3. Accuracy over Measuring Range for Rigid Single Lead/Segmented Rigid Single Probes

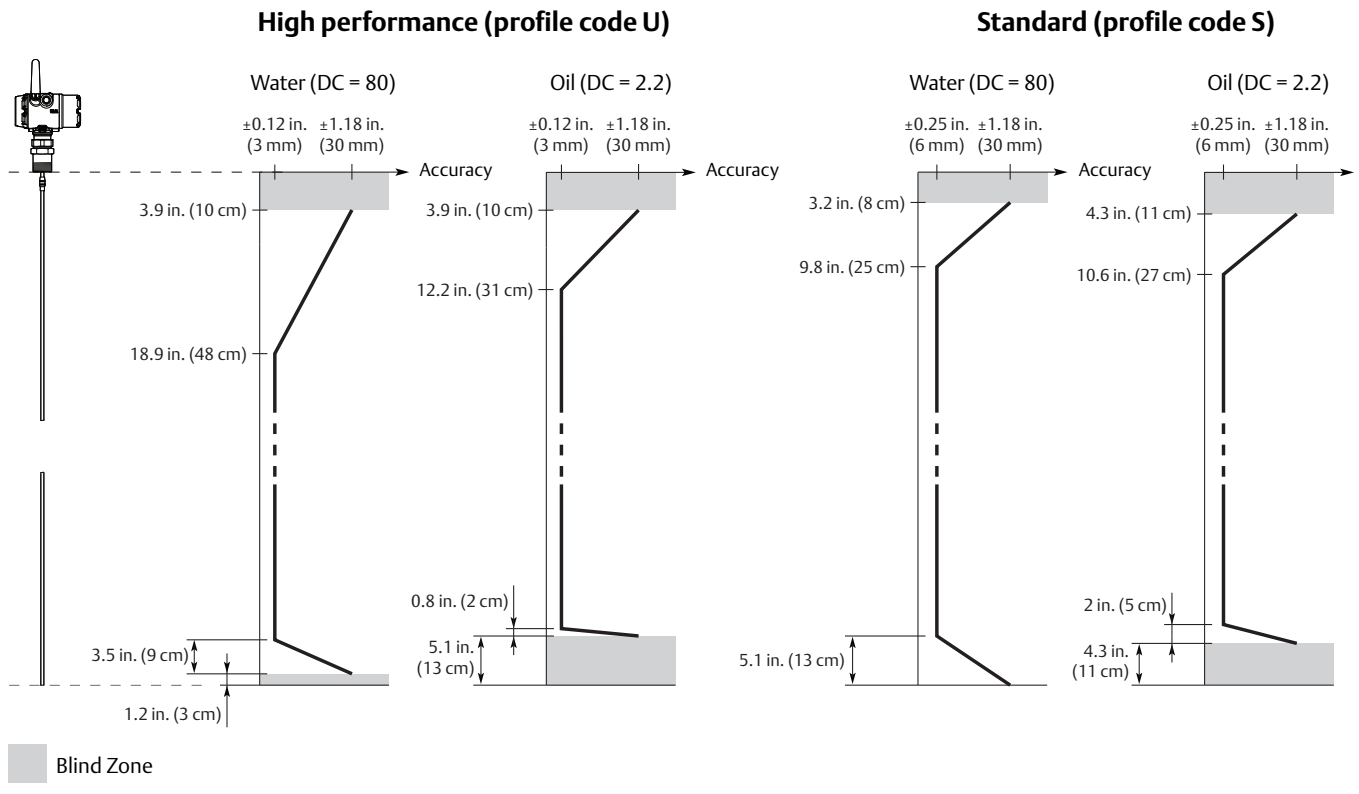

Figure 4. Accuracy over Measuring Range for Flexible Twin Lead Probe

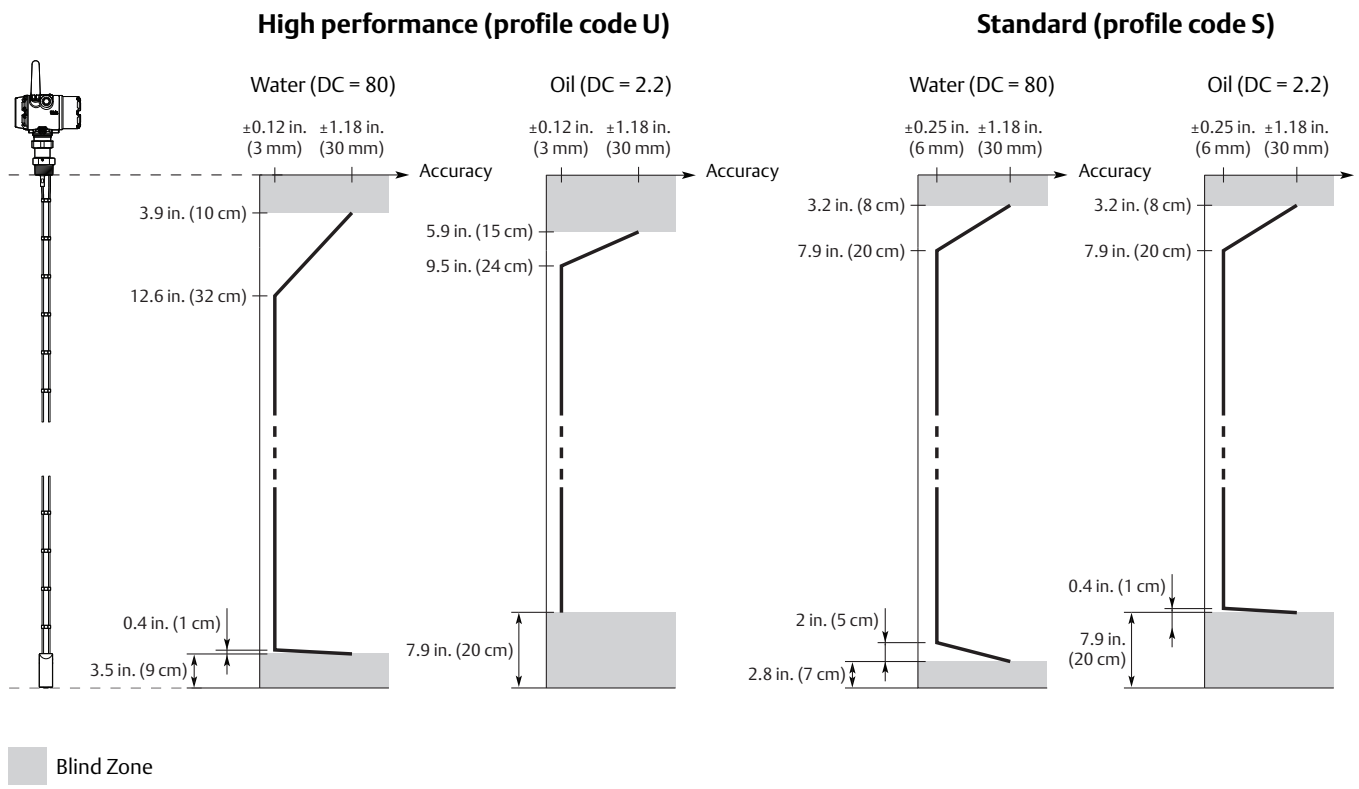
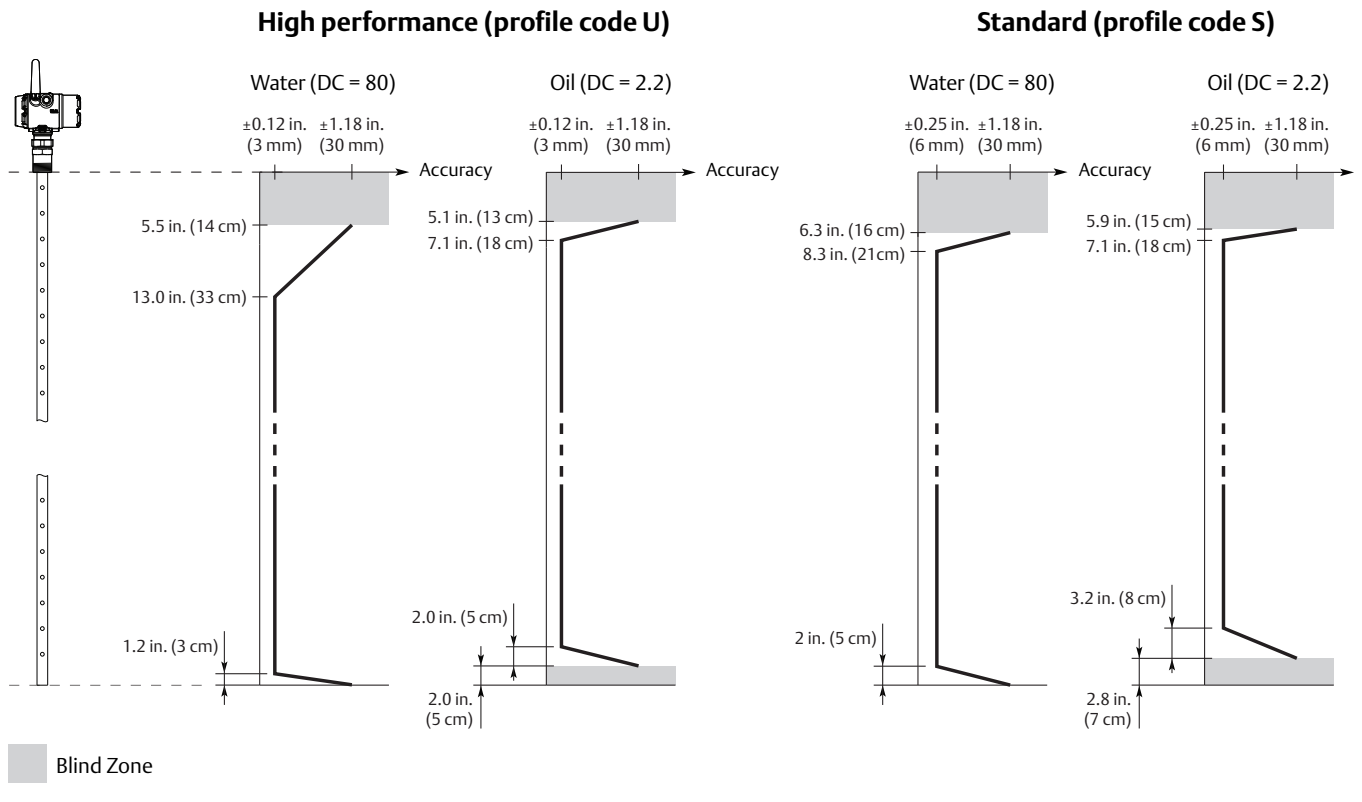

Figure 5. Accuracy over Measuring Range for Coaxial Probe



Functional specifications

General

Field of applications

Liquids and semi-liquids level or liquid/liquid interfaces

- 3308Axx1... for level or submerged probe interface measurement
- 3308Axx2... for level and interface measurement

Measurement principle

Time Domain Reflectometry (TDR)

(See “Introduction” on page 2 for a description of how it works)

Microwave output power

Nominal 10 μ W, Max <20 mW

Humidity limits

0 to 100% relative humidity

Wireless

Output

IEC 62591 (*WirelessHART*) 2.4 GHz

Transmit rate

User selectable, 4 seconds to 60 minutes

Frequency rate

2400 - 2483.5 MHz

Radio frequency output from antenna

- External antenna (WK1 option): < 10 mW (+10dBm) EIRP
- Remote (WN1 option): < 40mW (16dBm) EIRP

Modulation type

QPSK/iIEEE 802.15.4 IEC 62591 (*WirelessHART*)

Number of channels

15

Channel spacing

5 MHz

Emission designation

G1D

Display and configuration

LCD display

- Toggles between selected output variables
- Shows diagnostic information (alerts)
- Display updates at each wireless update

Figure 6. LCD Display

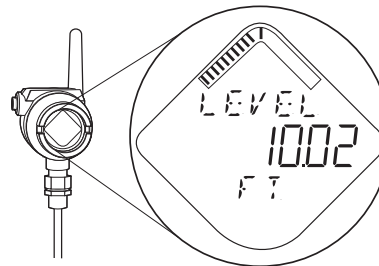

Output units

- Level, Interface, and Distance: ft, inch, m, cm, or mm
- Volume: ft³, inch³, US gals, Imp gals, barrels, yd³, m³, or liters
- Temperature: °F, °C

Table 7. Output Variables

Variable	LCD display	PV, SV, TV, QV
Level	✓	✓
Distance	✓	✓
Surface Signal Strength	N/A	✓
Total Volume	✓	✓
Interface Level ⁽¹⁾	✓	✓
Interface Distance ⁽¹⁾	✓	✓
Interface Signal Strength ⁽¹⁾	N/A	✓ ⁽²⁾
Upper Product Thickness ⁽³⁾	✓	✓
Electronics Temperature	✓	✓ ⁽²⁾
Signal Quality	✓	✓ ⁽²⁾
Supply Voltage	✓	✓ ⁽²⁾
% of Range	✓	✓ ⁽²⁾

1. For 3308Axx1, Interface measurement is only available for fully submerged probe.
2. Not available as primary variable.
3. Only available with 3308Axx2.

HART diagnostics

Signal Quality Metrics - Diagnostics package that monitors the relations between surface, noise and threshold. The function can be used to detect abnormal conditions in the process such as probe contamination or sudden loss of signal strength. Signal Quality is available as Output Variable and it comes with user configurable alerts through AMS Wireless Configurator or Field Communicator.

Temperature limits

Verify that the operating atmosphere of the transmitter is consistent with the appropriate hazardous locations certifications, see [“Product Certifications” on page 29.](#)

Table 8. Ambient Temperature Limits

Description	Operating limit	Storage limit
With LCD display	-40 to 175 °F (-40 to 80 °C) ⁽¹⁾	-40 to 185 °F (-40 to 85 °C)
Without LCD display	-40 to 185 °F (-40 to 85 °C)	-40 to 185 °F (-40 to 85 °C)

1. LCD display may not be readable and device display updates will be slower at temperatures below -4 °F (-20 °C).

Process temperature and pressure rating

Figure 7 gives the maximum process temperature (measured at the lower part of the flange or threaded connection) and pressure rating.

Final rating depends on flange, material of construction, and O-ring selection.

Figure 7. Max. Rating, Standard Tank Connections

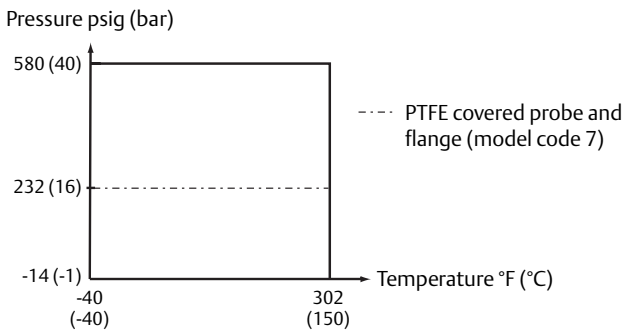

Table 9. Temperature Ranges for Standard Tank Seals With Different O-ring Materials

O-ring material	Temperature °F (°C) in air	
	Min.	Max.
Viton Fluoroelastomer	5 (-15)	302 (150)
Ethylene Propylene (EPDM)	-40 (-40)	266 (130)
Kalrez 6375 Perfluoroelastomer	14 (-10)	302 (150)
Nitrile Butadiene (NBR)	-31 (-35)	230 (110)

Note

Always check the chemical compatibility of the O-ring material with your application. If the O-ring material is not compatible with its chemical environment, the O-ring may eventually malfunction.

Flange rating

ASME

316L SST flanges according to ASME B16.5 Table 2-2.3:

- Max. 302 °F/580 psig (150 °C/40 bar)

Alloy C-276 (UNS N10276) flanges according to ASME B16.5 Table 2-3.8:

- Max. 302 °F/580 psig (150 °C/40 bar)

Duplex 2205 (UNS S31803) flanges according to ASME B16.5 Table 2-2.8:

- Max. 302 °F/580 psig (150 °C/40 bar)

EN

EN 1.4404 according to EN 1092-1 material group 13E0:

- Max. 302 °F/580 psig (150 °C/40 bar)

Alloy C-276 (UNS N10276) flanges according to EN 1092-1 material group 12E0:

- Max. 302 °F/580 psig (150 °C/40 bar)

Duplex 2205 (EN 1.4462) flanges according to EN 1092-1 material group 16E0:

- Max. 580 psig (40 Bar), -22 °F (-30 °C) up to max 302 °F (150 °C)⁽¹⁾

JIS

316L SST Flanges according to JIS B2220 material group 2.3:

- Max. 302 °F/580 psig (150 °C/40 bar)

Fisher and Masoneilan

316L SST Flanges according to ASME B16.5 Table 2-2.3:

- Max. 302 °F/580 psig (150 °C/40 bar)

1. Minimum temperature limit due to EN13445-2.

Table 10. Tri Clamp Rating

Size	Maximum pressure (bar) ⁽¹⁾
1½-in. (37.5 mm)	16
2-in. (50 mm)	16
3-in. (75 mm)	10
4-in. (100 mm)	10

1. The final rating depends on the clamp and gasket.

Plate design

Certain models of flanged alloy and PTFE covered probes have a tank connection design with a protective flange plate of the same material as the probe and with a backing flange in 316L/EN 1.4404. The protective flange plate prevents the backing flange from being exposed to the tank atmosphere.

Flange rating according to SST backing flange ASME B16.5 Table 2-2.3, EN 1092-1 material group 13E0, and JIS B2220 material group 2.3.

PTFE protective plate:

- Max. 302 °F/232 psig (150 °C/16 Bar)

Alloy C-276 and Alloy 400 protective plate:

- Max. 302 °F/580 psig (150 °C/40 Bar)

Interface measurements

The Rosemount 3308 Series is well suited for interface measurements, including applications where the probe is fully submerged in the liquid.

- The dielectric constant of the upper product must have a lower dielectric constant than the lower product to have a distinct reflection.
- The difference between the dielectric constants for the two products must be larger than 10.
- Maximum dielectric constant for the upper product is 10 for the coaxial probe, and 5 for the single lead and flexible twin lead probes.
- Minimum detectable upper product thickness is 4 in. (10 cm) when the upper product is oil (DC=2.2) and the lower product is water (DC=80).

For guidelines on emulsion, consult your local Emerson representative.

For additional information, see the Guided Wave Radar Interface Measurement [Technical Note](#).

Figure 8. Interface Measurements

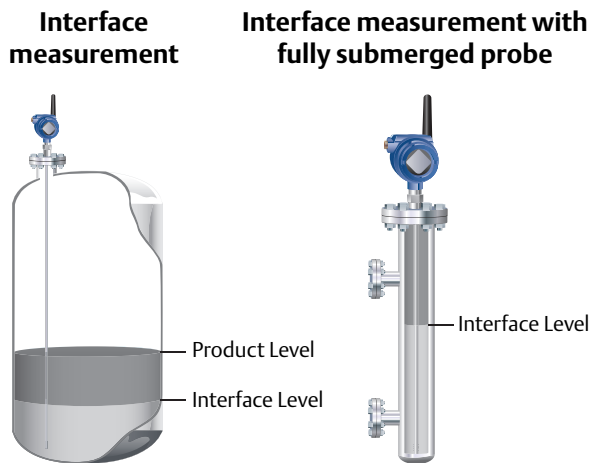

If interface is to be measured, follow these criteria:

- The dielectric constant of the upper product should be known and should not vary. The AMS Wireless Configurator and Field Communicator have a built-in Dielectric Constant Guide to assist the user in determining the dielectric constant of the upper product.

Conditions used for flange strength calculations

Table 11. 316L SST or Process Connection With Plate Design

Standard	Bolting material	Gasket	Flange material	Hub material
ASME	Stainless steel SA193 B8M Class 2	Soft (1a) with min. thickness 1.6 mm	Stainless steel A182 Gr. F316L and EN 10222-5-1.4404	Stainless steel SA479M 316L and EN 10272-1.4404
EN, JIS	EN 1515-1/-2 group 13E0, A4-70	Soft (EN 1514-1) with min. thickness 1.6 mm		

Table 12. Alloy C-276

Standard	Bolting material	Gasket	Flange material	Hub material
ASME	UNS N10276	Soft (1a) with min. thickness 1.6 mm	SB462 Gr. N10276 (solution annealed condition) or SB575 Gr. N10276 (solution annealed condition)	SB574 Gr. N10276
EN, JIS		Soft (EN 1514-1) with min. thickness 1.6 mm		

Table 13. Duplex 2205

Standard	Bolting material	Gasket	Flange material	Hub material
ASME	A193 B7 or A320 L7	Soft (1a) with min. thickness 1.6 mm	Duplex stainless steel SA/A182 F51 and EN10222-5-1.4462 or SA/A240 Gr. S31803 and EN10028-7-1.4462	Stainless steel SA479M S31803 and EN, JIS Bumax 88 EN 10272-1.4462
EN, JIS	Bumax® 88	Soft (EN 1514-1) with min. thickness 1.6 mm		

Physical specifications

Material selection

Emerson provides a variety of Rosemount products with various product options and configurations including materials of construction that can be expected to perform well in a wide range of applications. The Rosemount product information presented is intended as a guide for the purchaser to make an appropriate selection for the application. It is the purchaser's sole responsibility to make a careful analysis of all process parameters (such as all chemical components, temperature, pressure, flow rate, abrasives, contaminants, etc.), when specifying product, materials, options and components for the particular application. Emerson is not in a position to evaluate or guarantee the compatibility of the process fluid or other process parameters with the product, options, configuration or materials of construction selected.

Tank connection

The tank connection consists of a tank seal, a flange, Tri Clamp, or NPT or BSPP (G) threads. See "Dimensional Drawings" on page 32.

Certain models of flanged alloy and PTFE covered probes have a tank connection design with a protective plate of the same material as the probe (see Figure 9). This is to prevent the 316L/EN 1.4404 SST flange from being exposed to the tank atmosphere.

Figure 9. Probe and Protective Plate

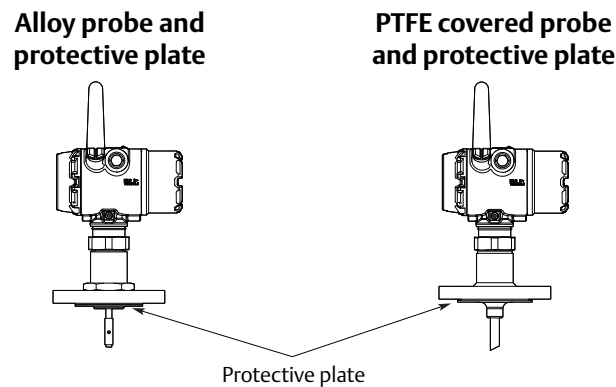

Housing and enclosure

Ingress protection

IP66/67 and NEMA® 4X

Flange dimensions

Follows ASME B16.5, JIS B2220, and EN 1092-1 standards for blind flanges. For Proprietary Fisher and Masoneilan flanges, see "Proprietary Flanges" on page 39.

Probes

Probe versions

Flexible single lead, rigid single lead, segmented rigid single lead, flexible twin lead, and coaxial.

Total probe length

This is defined from the Upper Reference Point to the end of the probe (weight included, if applicable).

Figure 10. Total Probe Length

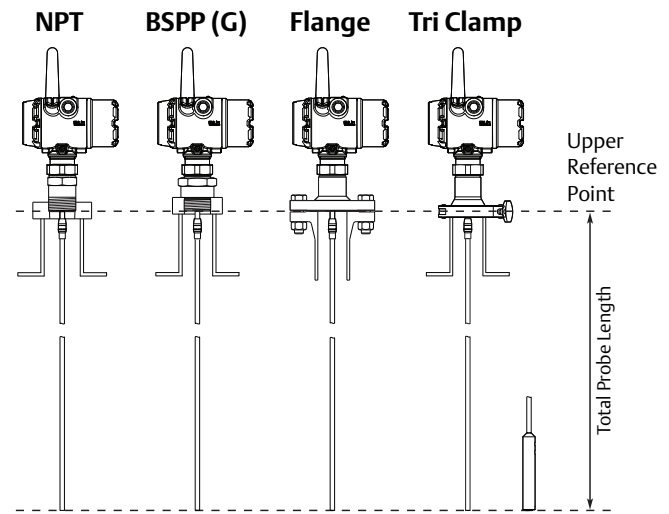

Select the probe length according to the required measuring range (the probe must be hung and fully extended through the entire distance where level readings are desired).

Cut-to-fit probes

All probes can be cut in field except for the PTFE covered probe. However, there are some restrictions for the coaxial probe: Probes over 4.1 ft. (1.25 m) can be cut up to 2 ft. (0.6 m). Shorter probes can be cut to the minimum length of 1.3 ft. (0.4 m).

Table 14. Minimum and Maximum Probe Length

Probe type	Probe length
Flexible single lead	3.3 to 55.8 ft. (1 to 17 m)
Rigid single lead (0.3-in./8 mm)	1.3 to 9.8 ft. (0.4 to 3 m)
Rigid single lead (0.5-in./13 mm)	1.3 to 19.7 ft. (0.4 to 6 m)
Segmented rigid single lead	1.3 to 32.8 ft. (0.4 to 10 m)
Flexible twin lead	3.3 to 55.8 ft. (1 to 17 m)
Coaxial	1.3 to 19.7 ft. (0.4 to 6 m)

Probe angle

0 to 90 degrees from vertical axis

Tensile strength

- Flexible single lead SST: 2698 lb (12 kN)
- Flexible single lead Alloy C-276: 1798 lb (8 kN)
- Flexible single lead Alloy 400: 1124 lb (5 kN)
- Flexible single lead Duplex 2205: 1349 lb (6 kN)
- Flexible twin lead: 2023 lb (9 kN)

Collapse load

- Flexible single lead SST: 3597 lb (16 kN)
- Flexible single lead Alloy C-276: 2023 lb (9 kN)
- Flexible single lead Alloy 400: 1349 lb (6 kN)
- Flexible single lead Duplex 2205: 1574 lb (7 kN)

Sideway capacity

- Rigid single lead/segmented rigid single lead:
4.4 ft. lbf, 0.44 lb at 9.8 ft. (6 Nm, 0.2 kg at 3 m)
- Coaxial: 73.7 ft. lbf, 3.7 lb at 19.7 ft. (100 Nm, 1.67 kg at 6 m)

Material exposed to tank atmosphere

Material of construction code	Material
1	316 SST ⁽¹⁾ , 316L SST (EN 1.4404), PTFE, PFA, and O-ring materials
2	Alloy C-276 (UNS N10276), PTFE, PFA, and O-ring materials
3	Alloy 400 (UNS N04400), PTFE, PFA, and O-ring materials
7	PTFE (1 mm PTFE cover)
8	PTFE, 316L SST (EN 1.4404), and O-ring materials
H	Alloy C-276 (UNS N10276), PTFE, PFA, and O-ring materials
D	Duplex 2205 (UNS S31803/EN 1.4462), Duplex 2507 (UNSS32750/EN 1.4410), PTFE, PFA, and O-ring materials

1. For flexible single/twin lead probes only.

Weight

Table 15. Flange and Probes

Item	Weight
Flange	Depends on flange size
Flexible single lead probe	0.05 lb/ft. (0.07 kg/m)
Rigid single lead probe (0.3-in./8 mm)	0.27 lb/ft. (0.4 kg/m)
Rigid single lead probe (0.5-in./13 mm)	0.71 lb/ft. (1.06 kg/m)
Segmented rigid single lead probe	0.71 lb/ft. (1.06 kg/m)
Flexible twin lead probe	0.09 lb/ft. (0.14 kg/m)
Coaxial probe	0.67 lb/ft. (1 kg/m)

Table 16. End Weight

Item	Weight
Small weight (code W1)	SST probe: 0.88 lb (0.40 kg)
	PTFE covered probe: 2.20 lb (1 kg)
Short weight (code W2)	0.88 lb (0.40 kg)
Heavy weight (code W3)	2.43 lb (1.10 kg)
Flexible twin lead probe	1.3 lb (0.60 kg)

End weight and anchoring options

There are in total four weight and anchoring options for flexible single lead probes. See [Figure 15 on page 32](#) for dimensions.

Small weight (code W1)

A small weight is recommended for narrow tank openings less than 1.5 in. (38 mm). Required weight option for PTFE covered probes.

Short weight (code W2)

A short weight is available for the single flexible stainless steel probe. It is recommended for maximized measuring ranges with measurements close to the probe end.

Heavy weight (code W3)

A heavy weight is the recommended choice for most applications.

Chuck (code W4)

To tie probe end to tank bottom.

Table 17. Minimum Clearance

Description	Flexible single lead	Rigid single lead/ segmented rigid single lead	Flexible twin lead	Coaxial
Recommended nozzle diameter	4 in. (100 mm) or more	4 in. (100 mm) or more	4 in. (100 mm) or more	> probe diameter
Min. nozzle diameter ⁽¹⁾	1.5 in. (38 mm)	1.5 in. (38 mm) for probe type 4A 2 in. (50 mm) for probe type 4B and 4S	2 in. (50 mm)	> probe diameter
Maximum nozzle height	4 in. (100 mm) + nozzle diameter ⁽²⁾	4 in. (100 mm) + nozzle diameter	4 in. (100 mm) + nozzle diameter	N/A
Min. clearance to tank wall or obstruction	4 in. (100 mm) if smooth metallic wall. 16 in. (400 mm) if disturbing objects or rugged metallic.	4 in. (100 mm) if smooth metallic wall. 16 in. (400 mm) if disturbing objects or rugged metallic.	4 in. (100 mm) if smooth metallic wall. 16 in. (400 mm) if disturbing objects or rugged metallic.	0 in. (0 mm)
Min. pipe/bypass diameter	Consult your local Emerson representative.	2 in. (50 mm)	Consult your local Emerson representative.	1.5 in. (38 mm)

1. The Trim Near Zone (TNZ) function may be necessary or an Upper Null Zone (UNZ) setup may be required to mask the nozzle.
2. For nozzles taller than 4 in. (100 mm), the Long Stud version is recommended (option code LS) to prevent the flexible portion from touching the edge of the nozzle.

Figure 11. Mounting in Nozzles and Free Space Requirement

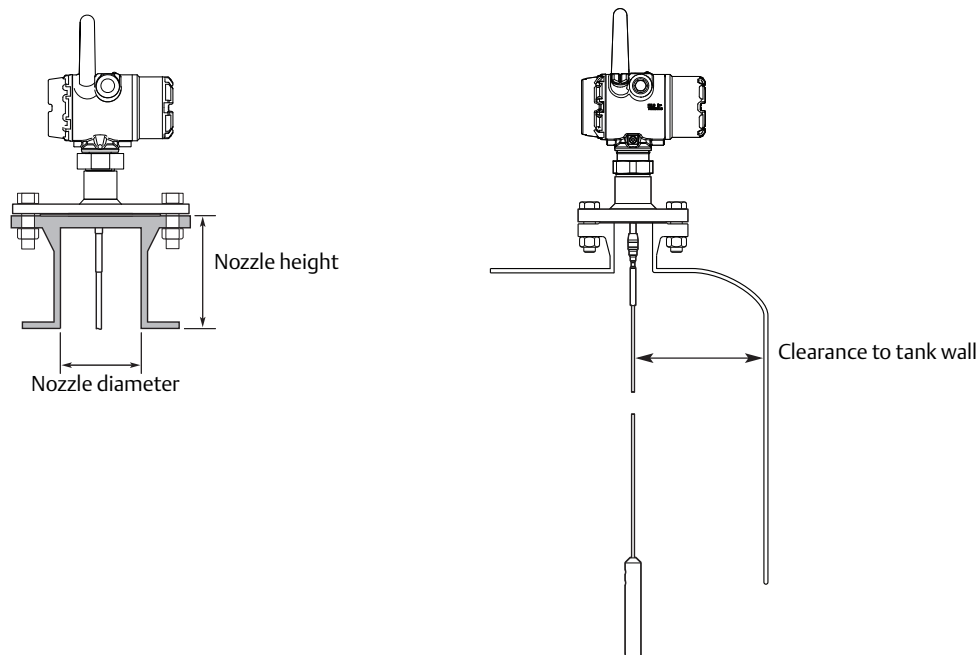

Installation in non-metallic tanks and open-air applications

- Avoid major sources of electrical disturbance in proximity of the installation, e.g. electrical motors, stirrers, servo mechanisms.

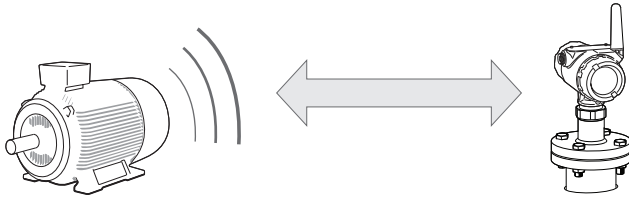

- For clean liquids, use a coaxial probe to reduce effect of potential electrical disturbances.

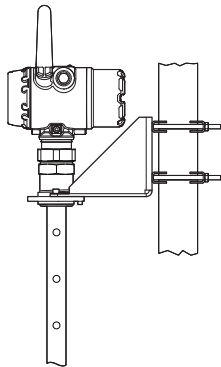

- For optimal single lead probe performance in non-metallic tanks, the probe must be mounted with a metal flange, or screwed in to a metal sheet ($d > 14$ in./350 mm) if a threaded version is used.

Metal flange

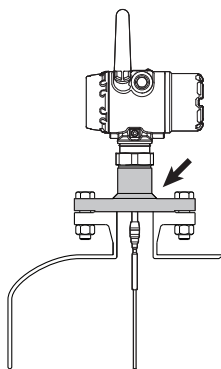

**Metal sheet
($d > 14$ in./350 mm)**

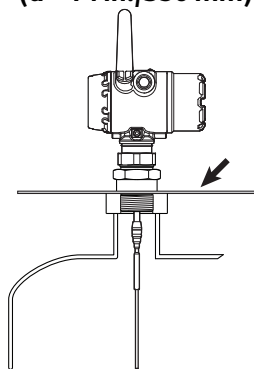

Other mechanical considerations

To get best possible performance, the following must be considered before installing the transmitter:

- Inlets should be kept at a distance in order to avoid product filling on the probe.
- Avoid physical contact between probes and agitators, as well as applications with strong fluid movement unless the probe is anchored.
- Probe tie-down is recommended if the probe can move to within 1 ft. (30 cm) of any object during operations.
- In order to stabilize the probe for side forces, it is possible to fix or guide the probe to the tank bottom

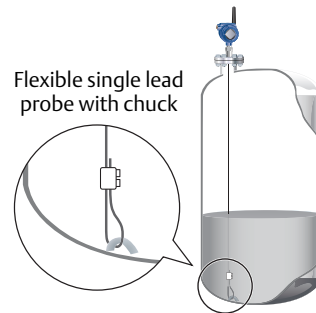

- Make sure the nozzle does not extend into the tank.

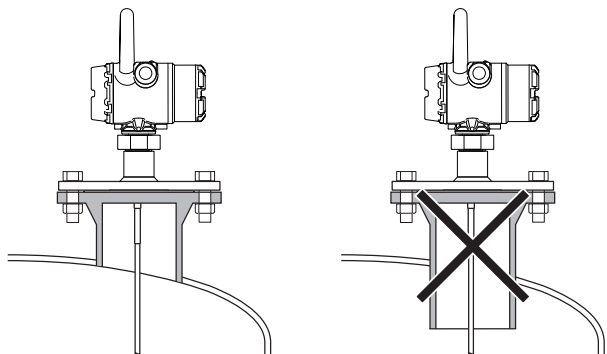

See the Rosemount 3308 Series Wireless Guided Wave Radar, 3308A [Reference Manual](#) for more mechanical installation information.

Engineered solutions

When standard model codes are not sufficient to fulfill requirements, please consult the factory to explore possible Engineered Solutions. This is typically, but not exclusively, related to the choice of wetted materials or the design of a process connection. These Engineered Solutions are part of the expanded offerings and may be subject to additional delivery lead time. For ordering, factory will supply a special P-labeled numeric option code that should be added at the end of the standard model string.

Chamber/pipe installations

General chamber considerations

A chamber or pipe installation is the preferred option due to the increase in stability and performance of the transmitter. When selecting a smaller diameter chamber or pipe (such as 2-in.) a flexible probe is not suitable due to the chance of it coming into contact with the walls, and relatively large side inlets may interfere with the signal.

When gas lift and/or turbulence may occur (e.g. boiling hydrocarbons), a 3- or 4-in. chamber/pipe diameter is recommended for maximum measurement reliability. This is especially true in high pressure and high temperature installations.

Rosemount 9901 Chamber

Rosemount 9901 allows external mounting of process level instrumentation. It supports a variety of process connections, and optional drain and vent connections. The Rosemount 9901 chamber is designed to the ASME B31.3 standard, and is Pressure Equipment Directive (PED) compliant. Use option code XC to order together with the Rosemount 3308 Series Transmitters.

Figure 12. Rosemount 9901 Chamber

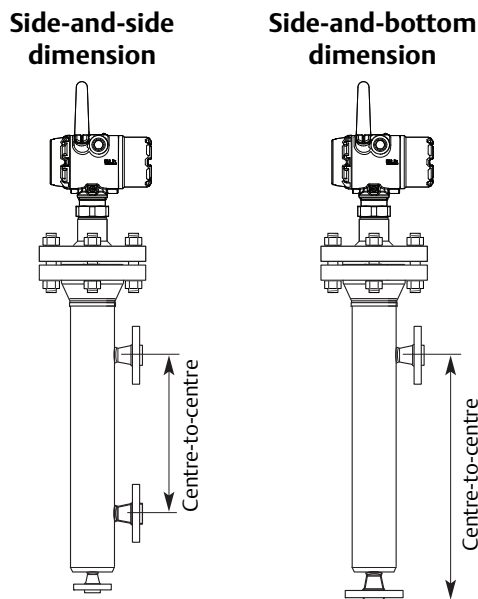

The probe length to use for a Rosemount 9901 chamber can be calculated with this formula:

Side-and-side dimension:

Probe length = Centre-to-centre dimension + 19 in. (48 cm)

Side-and-bottom dimension:

Probe length = Centre-to-centre dimension + 4 in. (10 cm)

Use a centering disc the same diameter as the chamber if the probe length >3.3 ft. (1 m). See Table 20 on page 28 for which disc to use.

For additional information, see the Rosemount 9901 Chamber for Process Level Instrumentation [Product Data Sheet](#).

Existing chamber

A Rosemount 3308 Series Transmitter is the perfect replacement in an existing displacer chamber. Proprietary flanges are offered, enabling use of existing chambers to make installation easy.

Figure 13. Existing Displacer Chamber

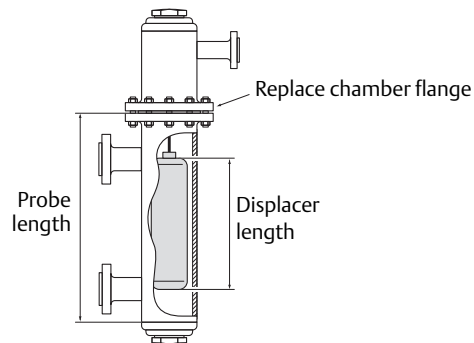

Considerations when changing to Rosemount 3308 Series:

- The Rosemount 3308 Series flange choice and probe length must be correctly matched to the chamber. Both standard ANSI and EN (DIN), as well as proprietary chamber flanges, are available. See “Proprietary Flanges” on page 39 to identify the proprietary flanges.
- See Table 20 on page 28 for guidelines on which disc size to use.
- See Table 18 for guidelines on the required probe length.

Table 18. Required Probe Length in Chambers

Chamber manufacturer	Probe length ⁽¹⁾
Major torque-tube manufacture (249B, 249C, 249K, 249N, 259B)	Displacer + 9 in. (229 mm)
Masoneilan (Torque tube operated), proprietary flange	Displacer + 8 in. (203 mm)
Other - torque tube ⁽²⁾	Displacer + 8 in. (203 mm)
Magnetrol® (spring operated) ⁽³⁾	Displacer + between 7.8 in. (195 mm) to 15 in. (383 mm)
Others - spring operated ⁽²⁾	Displacer + 19.7 in. (500 mm)

1. If flushing ring is used, add the ring height to the probe length.
2. For other manufacturers, there are small variations. This is an approximate value, actual length should be verified.
3. Lengths vary depending on model, SG and rating, and should be verified.

For additional information, see the Replacing Displacers with Guided Wave Radar [Technical Note](#).

Probe type in chamber considerations

When installing a Rosemount 3308 in a chamber, the single lead probe is recommended. The probe length determines if a single rigid or single flexible probe should be used:

- Less than 19.7 ft. (6.0 m):
Rigid single probe is recommended. Use a centering disc for probe > 3.3 ft. (1 m). When mounting space is limited, use a flexible single probe with a weight and centering disc.
- More than 19.7 ft. (6.0 m):
Use flexible single probe with a weight and centering disc.

PTFE covered probes are not recommended for chamber/pipe installations.

Centering discs

To prevent the probe from contacting the chamber or pipe wall, centering discs are available for rigid single, flexible single, and flexible twin lead probes. The disc is attached to the end of the probe. Discs are made of stainless steel, Alloy C-276, Duplex 2205, or PTFE.

Figure 14. Actual Disc Diameter (D)

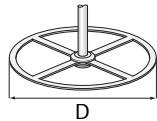

For the segmented rigid single lead probe, up to five PTFE centering discs can be mounted along the probe, but keep a minimum distance of two segments between the discs. Additionally, a disc in SST or PTFE (part number 03300-1655-xxxx) can be attached to the end of the probe.

When mounting a centering disc, it is important that it fits correctly in the chamber/pipe. See [Table 19](#) for Dimension D. [Table 20](#) shows which centering disc diameter to choose for a particular pipe.

Table 19. Centering Disc Dimensions

Disc size	Actual disc diameter (D)
2-in.	1.8 in. (45 mm)
3-in.	2.7 in. (68 mm)
4-in.	3.6 in. (92 mm)
6-in.	5.55 in. (141 mm)
8-in.	7.40 in. (188 mm)

Table 20. Centering Disc Size Recommendation for Different Pipe Schedules

Pipe size	Pipe schedule			
	5s, 5 and 10s,10	40s, 40 and 80s, 80	120	160
2-in.	2-in.	2-in.	N/A ⁽¹⁾	N/A ⁽²⁾
3-in.	3-in.	3-in.	N/A ⁽¹⁾	2-in.
4-in.	4-in.	4-in.	4-in.	3-in.
5-in.	4-in.	4-in.	4-in.	4-in.
6-in.	6-in.	6-in.	4-in.	4-in.
7-in.	N/A ⁽¹⁾	6-in.	N/A ⁽¹⁾	N/A ⁽¹⁾
8-in.	8-in.	8-in.	6-in.	6-in.

1. Schedule is not available for pipe size.
2. No centering disc is available.

Product Certifications

European Union directive information

The EU Declaration of Conformity for all applicable European directives for this product can be found on Emerson.com/Rosemount. A hard copy may be obtained by contacting your local sales representative.

Telecommunication compliance

All wireless devices require certification to ensure that they adhere to regulations regarding the use of the RF spectrum. Nearly every country requires this type of product certification. Emerson is working with governmental agencies around the world to supply fully compliant products and remove the risk of violating country directives or laws governing wireless device usage.

FCC and IC

This device complies with Part 15 of the FCC Rules. Operation is subject to the following conditions: This device may not cause harmful interference that may cause undesired operation. This device must be installed to ensure a minimum antenna separation distance of 20 cm from all persons.

This radio transmitter has been approved by Industry Canada to operate with the antenna types listed below with the maximum permissible gain indicated. Antenna types not included in this list, having a gain greater than the maximum gain indicated for that type, are strictly prohibited for use with this device.

Antenna model option	Antenna type	Max gain (dBi)
WK1	Integral Omni-directional	2
WN1	Remote Omni-directional	8

This device complies with Industry Canada license-exempt RSS standard(s). Operation is subject to the following two conditions: (1) This device may not cause interference, and (2) this device must accept any interference, including any interference that may cause undesired operation of the device.

Caution

Changes or modifications to the equipment not expressly approved by Emerson could void the user's authority to operate the equipment.

Ordinary location certification for FM approvals

As standard, the transmitter has been examined and tested to determine that the design meets basic electrical, mechanical, and fire protection requirements by FM Approvals, a nationally recognized testing laboratory (NRTL) as accredited by the Federal Occupational Safety and Health Administration (OSHA).

Hazardous locations certificates

U.S.A.

- I5** U.S.A Intrinsicly Safe
 Certificate: FM17US0014X
 Standards: FM Class 3600 – 2011, FM Class 3610 – 2015, FM Class 3810 – 2005, NEMA 250 – 2003, ANSI/ISA 60079-0:2013, ANSI/UL 60079-11:2014, ANSI/ISA 60529:2004, ANSI/ISA 61010-1:2004
 Markings: IS CL I, DIV 1, GP A, B, C, D;
 IS CL I Zone 0, AEx ia IIC T4 Ga;
 T4 Ta = -55 to +70 °C
 Type 4X; IP66; IP67
 WHEN INSTALLED PER ROSEMOUNT DRAWING 03308-1010

Special Conditions of Certification:

1. The Model 3308 transmitter housing contains aluminum; protect the enclosure to avoid a potential risk of ignition due to impact or friction.
2. The surface resistivity of the polymeric antenna is greater than 1GΩ. To avoid electrostatic charge buildup, it must not be rubbed or cleaned with solvents or a dry cloth.
3. For use only with the Emerson Process Management Model 701PBKKF SmartPower Option or the Computational Systems, Inc Model MHM-89004 battery module.
4. Only the Emerson Process Management 375 or 475 Field Communicator is approved for use with this transmitter.
5. The maximum permitted operating temperature of the Rosemount 3308A transmitter is 70 °C. To avoid the effects of process temperature and other thermal effects care shall be taken to ensure that the "Electronics Temperature" does not exceed 70 °C.

Canada

- I6** Canada Intrinsicly Safe
 Certificate: FM17CA0007X
 Standards: CSA Std. C22.2 No. 61010-1:2004, CSA Std. 22.2 No. 94-M91, CAN/CSA-C22.2 NO. 60079-0:15, CAN/CSA-C22.2 NO. 60079-11:14, C22.2 No. 60529:2016

Markings: INTRINSICALLY SAFE Ex ia
 CLASS I, GP A, B, C, D;
 CLASS I, Zone 0, Ex ia IIC T4 Ga;
 TEMP CODE T4 (-55 °C ≤ Ta ≤ +70 °C)
 Type 4X; IP66; IP67
 WHEN INSTALLED PER ROSEMOUNT DRAWING
 03308-1010

Special Conditions of Certification:

1. The Model 3308 transmitter housing contains aluminum; protect the enclosure to avoid a potential risk of ignition due to impact or friction.
2. The surface resistivity of the polymeric antenna is greater than 1GΩ. To avoid electrostatic charge buildup, it must not be rubbed or cleaned with solvents or a dry cloth.
3. For use with the Emerson Process Management 701PBKKF SmartPower Option or the Computational Systems, Inc Model MHM-89004 battery module only.
4. Only the Emerson Process Management 375 or 475 Field Communicator is approved for use with this transmitter.
5. The maximum permitted operating temperature of the Rosemount 3308A transmitter is 70 °C. To avoid the effects of process temperature and other thermal effects care shall be taken to ensure that the “Electronics Temperature” does not exceed 70 °C.

Europe

I1 ATEX Intrinsic Safe

Certificate: FM 12ATEX0072X

Standards: EN 60079-0:2012+A11:2013, EN 60079-11:2012; EN 60529:1991+A2:2013

Markings:  Category II 1 G, Ex ia IIC T4 Ga
 (-55 °C ≤ Ta ≤ +70 °C);

 1180
 2460

Special Conditions of Certification:

1. The Model 3308 transmitter housing contains aluminum; protect the enclosure to avoid a potential risk of ignition due to impact or friction.
2. The surface resistivity of the polymeric antenna is greater than 1GΩ. To avoid electrostatic charge buildup, it must not be rubbed or cleaned with solvents or a dry cloth.
3. For use only with the ATEX certified (Baseefa11ATEX0042X) Emerson Process Management Model 701PBKKF SmartPower Option or the ATEX certified (SIRA 15ATEX2332X) Computational Systems, Inc Model MHM-89004 battery Module.
4. Only an ATEX certified (BVS03ATEXE347, BVS09ATEXE023) Emerson Process Management 375 or 475 Field Communicator is approved for use with this transmitter.

5. The maximum permitted operating temperature of the Rosemount 3308A transmitter is 70 °C. To avoid the effects of process temperature and other thermal effects care shall be taken to ensure that the “Electronics Temperature” does not exceed 70 °C.

International

I7 IECEx Intrinsic Safety

Certificate: IECEx FMG 12.0029X

Standards: IEC 60079-0: 2011, IEC 60079-11: 2011

Markings: Ex ia IIC T4 Ga (-55 °C ≤ Ta ≤ +70 °C)

Special Conditions of Certification:

1. The Model 3308 transmitter housing contains aluminum; protect the enclosure to avoid a potential risk of ignition due to impact or friction.
2. The surface resistivity of the polymeric antenna is greater than 1GΩ. To avoid electrostatic charge buildup, it must not be rubbed or cleaned with solvents or a dry cloth.
3. For use with only the an IECEx certified (IECEx FMG 12.0029X) Emerson Process Management Model 701PBKKF SmartPower Option or the IECEx certified (IECEx CSA 15.0045X) Computational Systems, Inc Model MHM-89004 battery pack.
4. Only the Emerson Process Management 375 or 475 Field Communicator is approved for use with this transmitter.
5. The maximum permitted operating temperature of the Rosemount 3308A transmitter is 70 °C. To avoid the effects of process temperature and other thermal effects care shall be taken to ensure that the “Electronics Temperature” does not exceed 70 °C.

Brazil

I2 INMETRO Intrinsic Safety

Certificate: UL-BR 13.0463X

Standards: ABNT NBR IEC 60079-0:2008 + Errata 1:2011,
 ABNT NBR IEC 60079-11:2009,
 ABNT NBR IEC 60079-26:2008

Markings: Ex ia IIC T4 Ga (-55 °C ≤ T_{amb} ≤ +70 °C)

Special Conditions of Certification:

1. The Model 3308 transmitter housing contains aluminium; protect the enclosure to avoid a potential risk of ignition due to impact or friction.
2. The surface resistivity of the polymeric antenna is greater than 1 GΩ. To avoid electrostatic charge buildup, it must not be rubbed or cleaned with solvents or a dry cloth.
3. For use with the Emerson Process Management 701PB SmartPower Option only.
4. Only the Emerson Process Management 375 or 475 Field Communicator is approved for use with this transmitter.

5. The maximum permitted operating temperature of the Rosemount 3308A transmitter is 70 °C. To avoid the effects of process temperature and other thermal effects care shall be taken to ensure that the “Electronics Temperature” does not exceed 70 °C.

China

I3 NEPSI Intrinsic Safety

Certificate: GYJ13.1443X

Standards: GB 3836.1-2010, GB 3836.4-2010,
GB 3836.20-2010

Markings: Ex ia IIC T4 Ga (-55°C~+70°C)

Special Conditions of Certification:

See certificate for details.

Japan

I4 TIIS Intrinsic Safety

Certificate: TC20746

Markings: Ex ia IIC T4 -20°~+60°C

Special Conditions of Certification:

See certificate for details.

EAC – Belarus, Kazakhstan, Russia

IM Technical Regulation Customs Union (EAC) Intrinsic Safety

Certificate: RU C-US.Gb05.B.00530

Markings: 0Ex ia IIC T4 Ga X (-55°C ≤ Ta ≤ +70°C)

Special Conditions of Certification:

See certificate for details.

Taiwan

注意！

依據 低功率電波輻射性電機管理辦法
第十二條

經型式認證合格之低功率射頻電機，非經許可，公司、商號或使用者均不得擅自變更頻率、加大功率或變更原設計之特性及功能。

第十四條

低功率射頻電機之使用不得影響飛航安全及干擾合法通信；經發現有干擾現象時，應立即停用，並改善至無干擾時方得繼續使用。

前項合法通信，指依電信法規定作業之無線電通信。

低功率射頻電機須忍受合法通信或工業、科學及醫療用電波輻射性電機設備之干擾。

Combinations

- KD** ATEX and Canadian Intrinsic Safety
KE FM and Canadian Intrinsically Safe
KF ATEX and FM Intrinsic Safety

Other certifications

U1 Overfill protection

Certificate: Z-65.16-536

TÜV-tested and approved by DIBt for overfill protection according to the German WHG regulations

Dimensional Drawings

Figure 15. Flexible Single Lead Probe

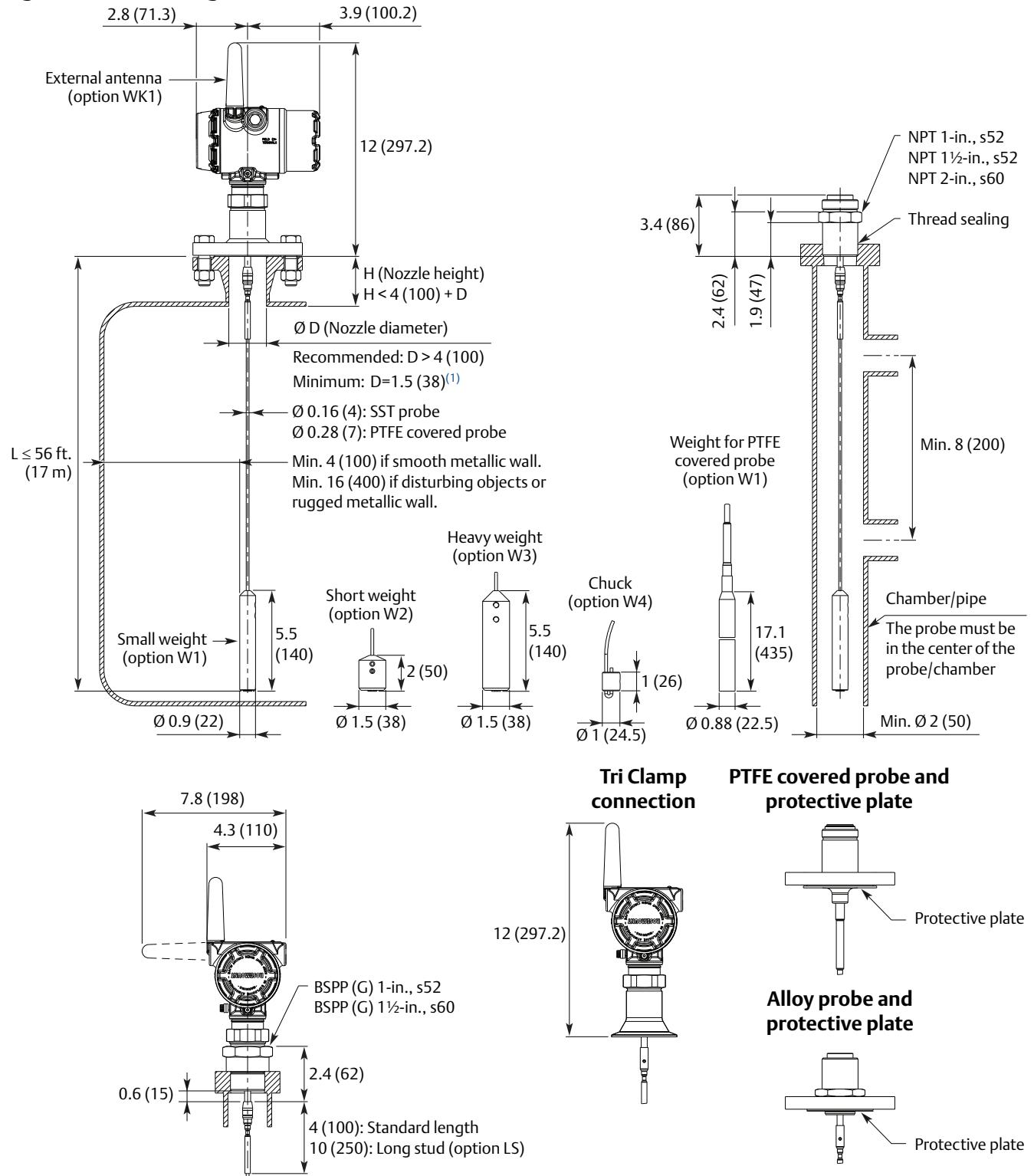

1. The Trim Near Zone (TNZ) function may be necessary or an Upper Null Zone (UNZ) setup may be required to mask the nozzle. Dimensions are in inches (millimeters).

Figure 16. Rigid Single Lead Probe

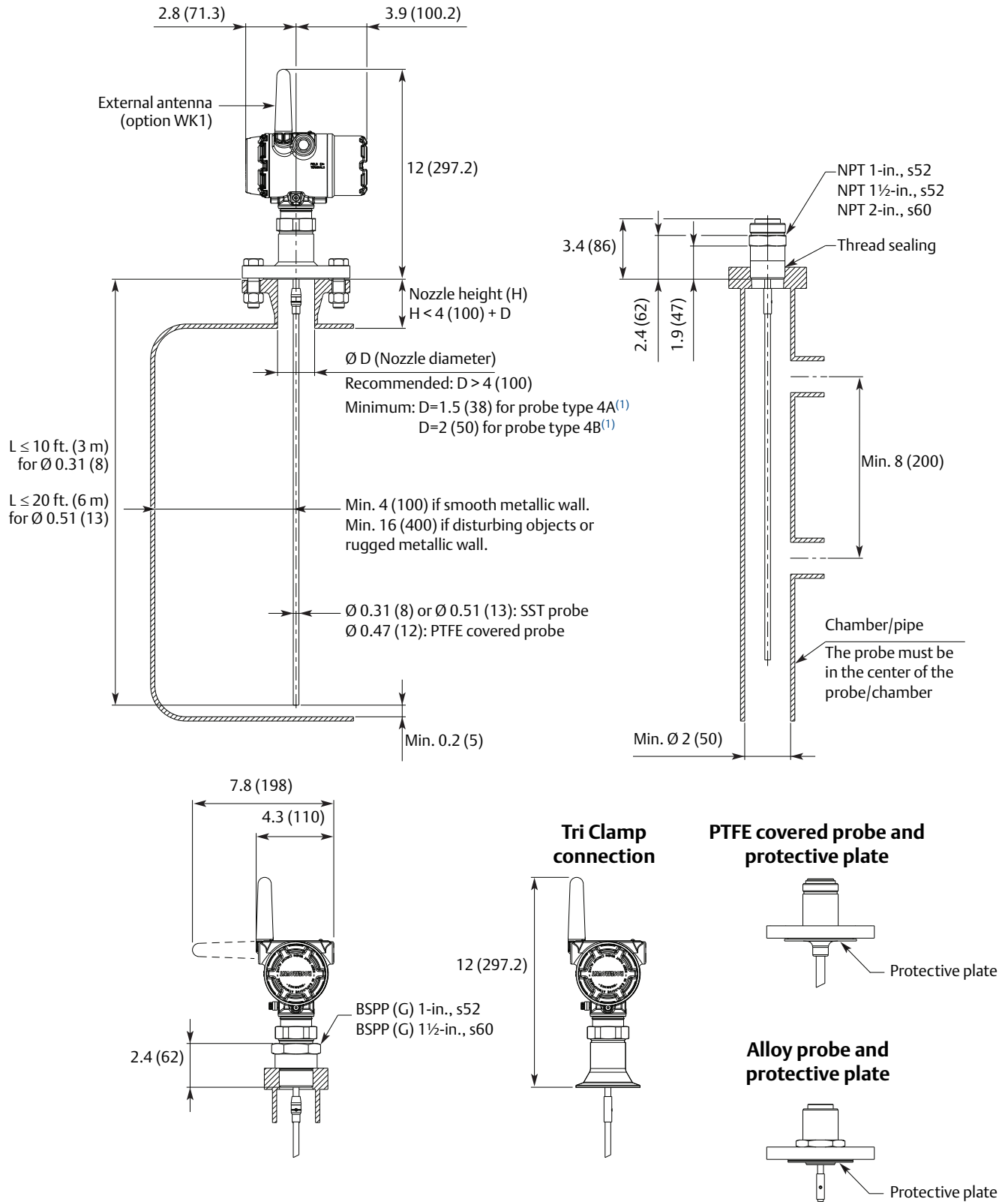

1. The Trim Near Zone (TNZ) function may be necessary or an Upper Null Zone (UNZ) setup may be required to mask the nozzle. Dimensions are in inches (millimeters).

Figure 17. Segmented Rigid Single Lead Probe

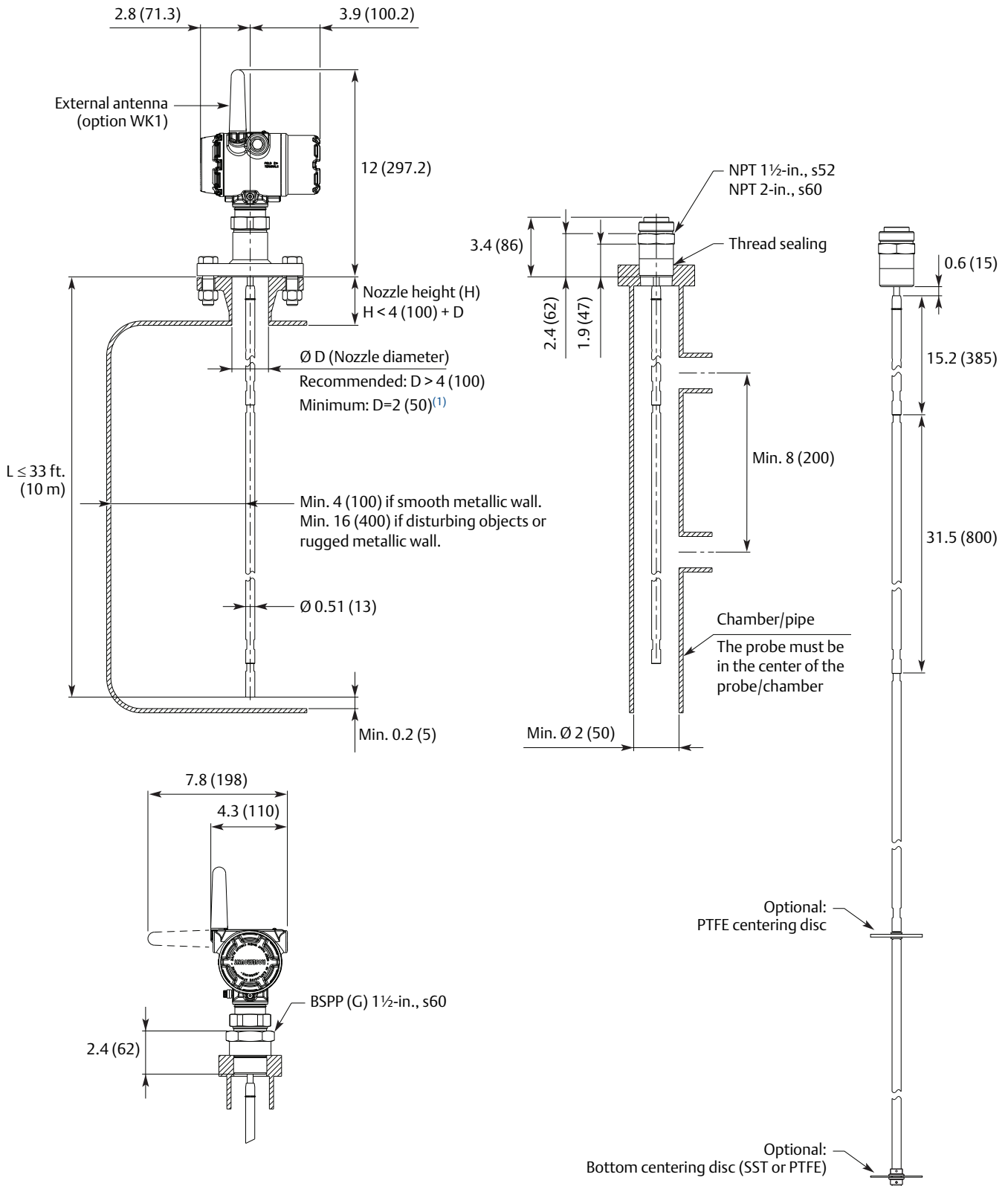

1. The Trim Near Zone (TNZ) function may be necessary or an Upper Null Zone (UNZ) setup may be required to mask the nozzle.

Dimensions are in inches (millimeters).

Figure 18. Coaxial Probe

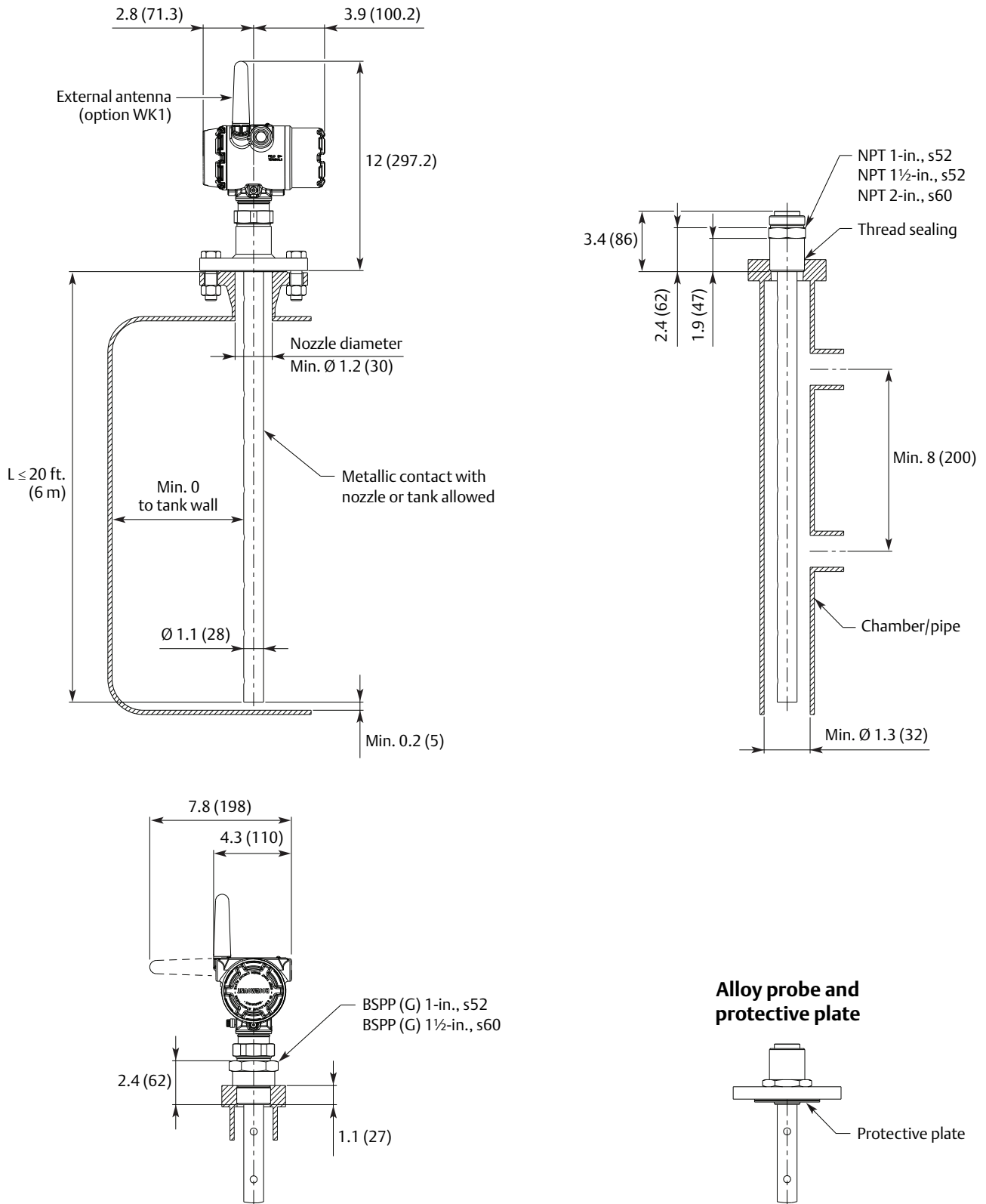

Dimensions are in inches (millimeters).

Figure 19. Flexible Twin Lead Probe

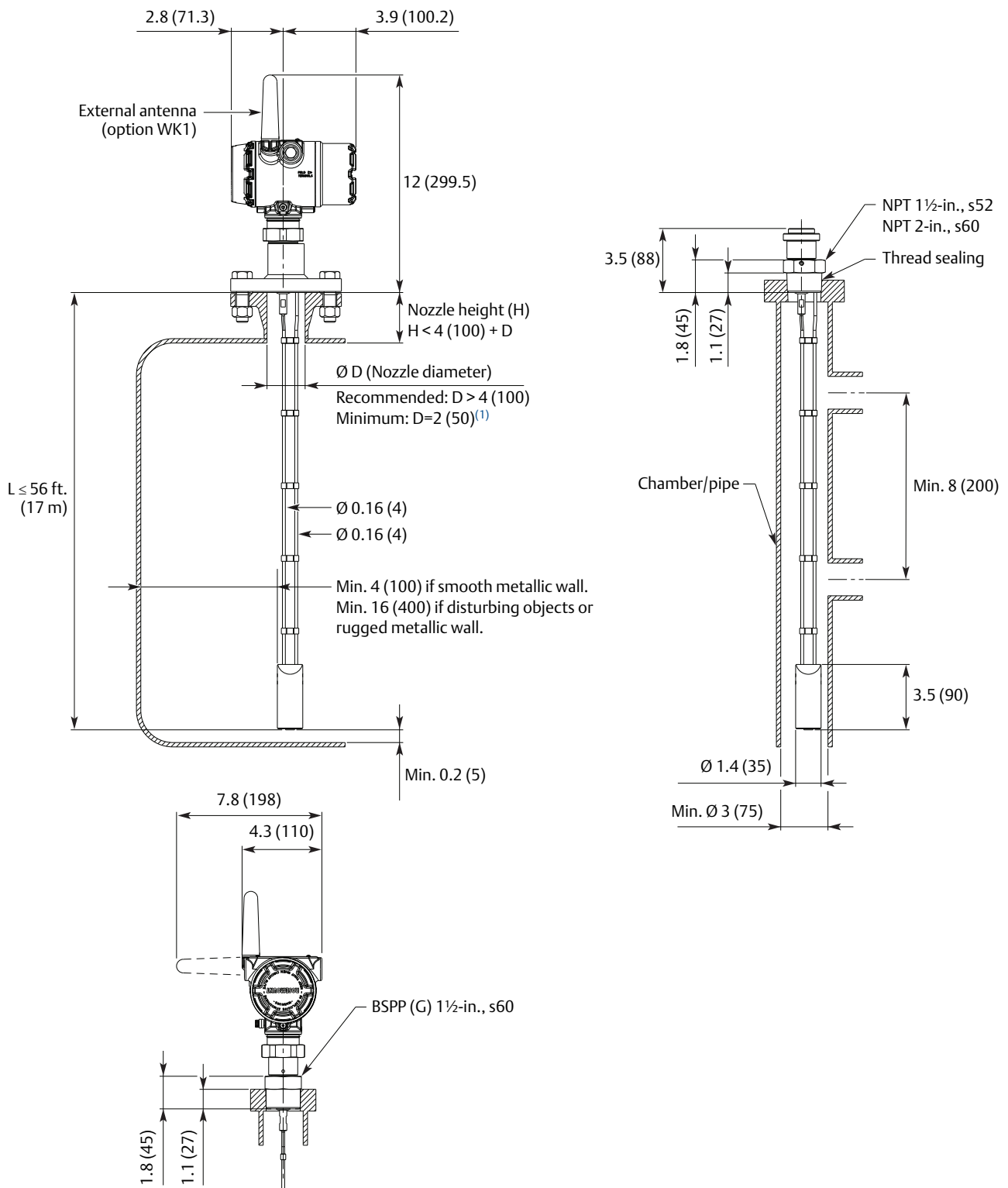

1. The Trim Near Zone (TNZ) function may be necessary or an Upper Null Zone (UNZ) setup may be required to mask the nozzle.

Dimensions are in inches (millimeters).

Figure 20. Mounting Bracket (Option Code BR)

Pipe mounting
(vertical pipe)

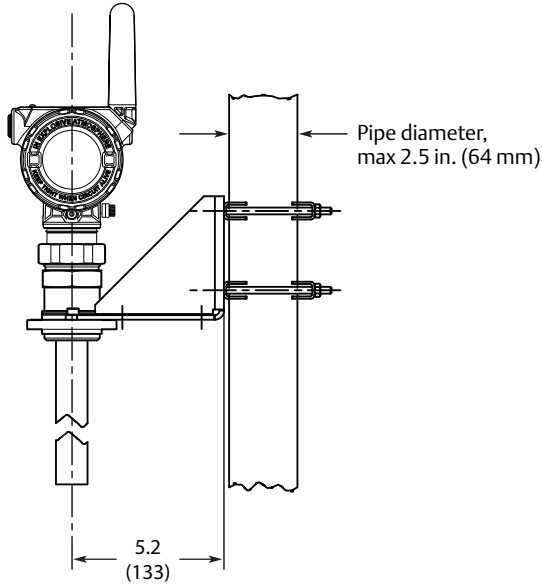

Pipe mounting
(horizontal pipe)

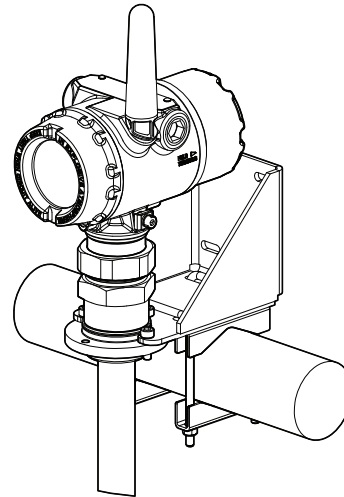

Wall mounting

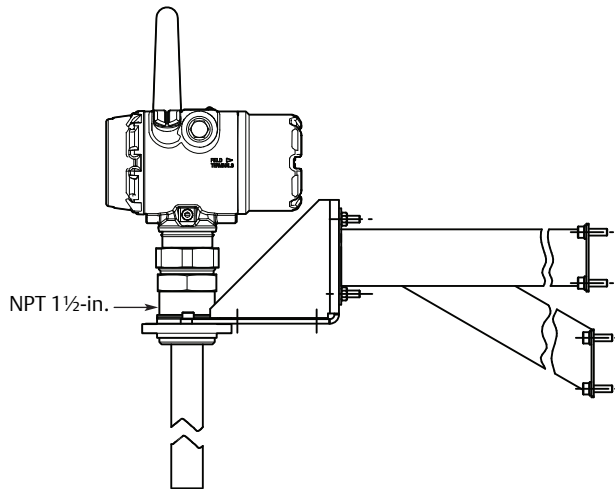

Hole pattern for wall mounting

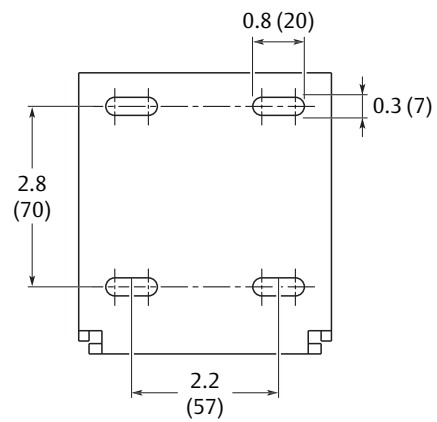

Dimensions are in inches (millimeters).

Figure 21. High Gain, Remote Antenna (Option Code WN1)

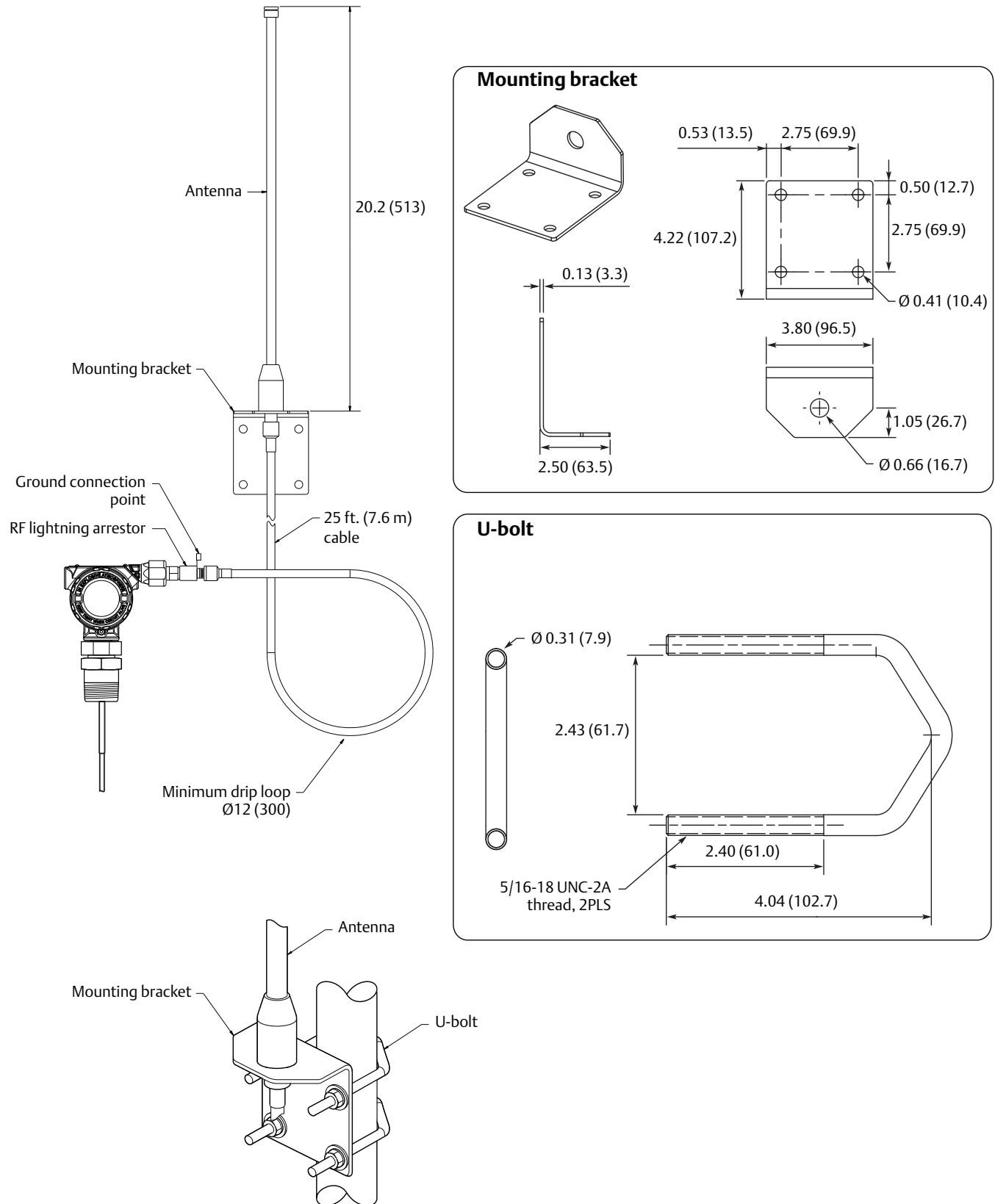

Dimensions are in inches (millimeters).

Figure 22. Proprietary Flanges

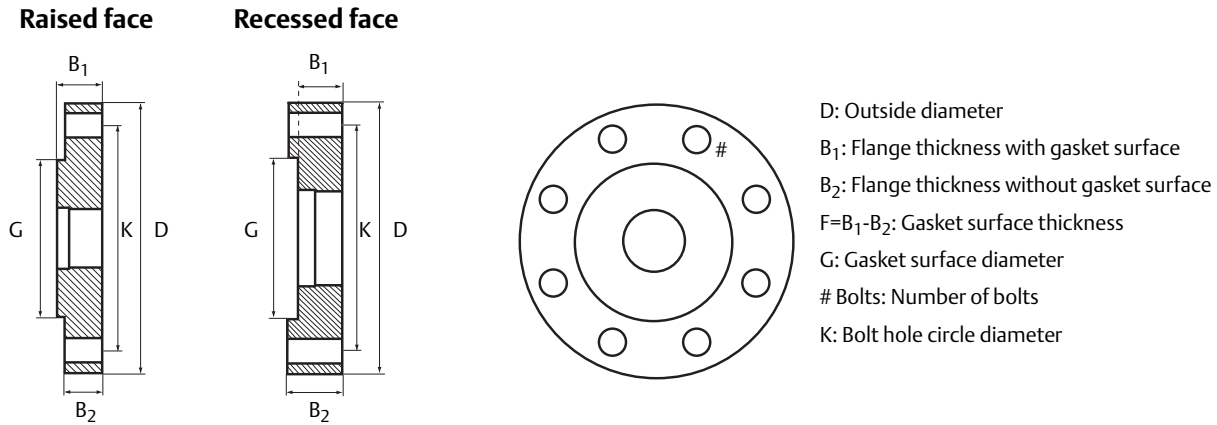

Dimensions are in inches (millimeters).

Note

Dimensions may be used to aid in the identification of installed flanges. It is not intended for manufacturing use.

Table 21. Dimensions of Proprietary Flanges

Special flanges ⁽¹⁾	D	B ₁	B ₂	F	G	# Bolts	K
Fisher 249B/259B ⁽²⁾	9.00 (228.6)	1.50 (38.2)	1.25 (31.8)	0.25 (6.4)	5.23 (132.8)	8	7.25 (184.2)
Fisher 249C ⁽³⁾	5.69 (144.5)	0.94 (23.8)	1.13 (28.6)	-0.19 (-4.8)	3.37 (85.7)	8	4.75 (120.65)
Masoneilan ⁽²⁾	7.51 (191.0)	1.54 (39.0)	1.30 (33.0)	0.24 (6.0)	4.02 (102.0)	8	5.87 (149.0)

1. These flanges are also available in a vented version.
2. Flange with raised face.
3. Flange with recessed face.

Complementary point level monitoring

An ideal complement to the Rosemount 3308, the Rosemount 2160 Wireless Level Detector provides reliable high/low level alarms and overfill protection, wirelessly communicating output and advanced instrument health.

With an update rate of up to one second, the Rosemount 2160 may be used in both monitoring and control applications.

See the Rosemount 2160 [Product Data Sheet](#).





Global Headquarters

Emerson Automation Solutions

6021 Innovation Blvd.

Shakopee, MN 55379, USA



 +1 800 999 9307 or +1 952 906 8888 +1 952 949 7001 RFQ.RMD-RCC@Emerson.com

North America Regional Office

Emerson Automation Solutions

8200 Market Blvd.

Chanhassen, MN 55317, USA



 +1 800 999 9307 or +1 952 906 8888 +1 952 949 7001 RMT-NA.RCCRFQ@Emerson.com

Latin America Regional Office

Emerson Automation Solutions

1300 Concord Terrace, Suite 400

Sunrise, FL 33323, USA

 +1 954 846 5030 +1 954 846 5121 RFQ.RMD-RCC@Emerson.com



Europe Regional Office

Emerson Automation Solutions Europe GmbH

Neuhofstrasse 19a P.O. Box 1046

CH 6340 Baar

Switzerland



 +41 (0) 41 768 6111 +41 (0) 41 768 6300 RFQ.RMD-RCC@Emerson.com

Asia Pacific Regional Office

Emerson Automation Solutions Asia Pacific Pte Ltd

1 Pandan Crescent

Singapore 128461

 +65 6777 8211 +65 6777 0947 Enquiries@AP.Emerson.com



Middle East and Africa Regional Office

Emerson Automation Solutions

Emerson FZE P.O. Box 17033

Jebel Ali Free Zone - South 2

Dubai, United Arab Emirates

 +971 4 8118100 +971 4 8865465 RFQ.RMTMEA@Emerson.com[Linkedin.com/company/Emerson-Automation-Solutions](https://www.linkedin.com/company/Emerson-Automation-Solutions)[Twitter.com/Rosemount_News](https://twitter.com/Rosemount_News)[Facebook.com/Rosemount](https://www.facebook.com/Rosemount)[Youtube.com/user/RosemountMeasurement](https://www.youtube.com/user/RosemountMeasurement)[Google.com/+RosemountMeasurement](https://www.google.com/+RosemountMeasurement)

Standard Terms and Conditions of Sale can be found on the [Terms and Conditions of Sale page](#).

The Emerson logo is a trademark and service mark of Emerson Electric Co.

DeltaV, Fisher, Ovation, Plantweb, Rosemount, Rosemount logotype, and SmartPower are trademarks of Emerson.

Bumax is a registered trademark of the Bufab Group.

HART and WirelessHART are registered trademarks of the FieldComm Group.

Kalrez and Viton are registered trademarks of DuPont.

MACTek and VIATOR are registered trademarks of MACTek Corporation.

Magnetrol is a registered trademark of Magnetrol International, Incorporated.

Masoneilan is a trademark of the General Electric Company.

NACE is a registered trademark of NACE International.

NEMA is a registered trademark and service mark of the National Electrical Manufacturers Association.

Wi-Fi is a registered trademark of Wi-Fi Alliance.

All other marks are the property of their respective owners.

© 2018 Emerson. All rights reserved.