

# 330505 Low Frequency Velocity Sensor

## Datasheet

Bently Nevada Machinery Condition Monitoring

---



### Description

The Bently Nevada 330505 Low Frequency Velocity Sensor is specifically designed for hydroelectric turbines where slow rotating speeds require detecting a low signal to noise ratio. It detects vibration of the stator core, stator frame, and bearing housing supports. It is designed to provide early warning of pending machinery problems and to help you diagnose problems before they become serious.

The sensor measures absolute vibration within the 0.5Hz to 1.0kHz range. Its two-wire design uses moving-coil technology and embedded signal conditioning circuitry to provide a voltage output directly proportional to the vibration velocity.

Stator core and stator frame vibration can cause fretting and damage to the winding insulation. To detect these problems before serious damage occurs, mount a 330505 sensor on the outer diameter of the stator core and frame.

Bearing housing vibration can distort levels of vibration measured by shaft-observing proximity probes. To detect premature failure of machine components and prevent significant machine problems, place 330505 sensors in locations that measure both shaft-relative and bearing-absolute vibration signals. You can mount 330505 sensors to the bearing housing either as a stand-alone measurement or in the same orientation as existing proximity sensors.

The 330505 Transducer connects to the 3500/46M Hydro Monitor, meeting the requirements of International Organization for Standardization (ISO) Standard 10816-5 for mechanical vibration on non-rotating parts in hydraulic power and pumping plants.

Due to the nature of high amplitude, low frequency velocity events, the 330505 Low Frequency Velocity Sensor is not recommended for automated machinery protection. Due to capacitance constraints, this sensor is not approved for hazardous areas.



## Specifications

Parameters are specified from +20 to +30°C (+68 to +86°F) and 80Hz unless otherwise indicated.

 Operation outside the specified limits may result in false readings or loss of machine monitoring.

## Electrical

Sensitivity	20 mV/mm/s (508mV/in/s) ±10%
Frequency Response	0.5—1000 Hz (30—60,000 cpm) ±3.0 dB; 1—200 Hz (60—12,000 cpm) ±0.9 dB
Velocity Range	102 mm/s (4 in/s) peak
Amplitude Range	<a href="#">See "330505 Vibration Nomograph " on page 6</a>
Amplitude Linearity	±3%—102 mm/s (4 in/s) peak
Output Bias Voltage	-12 ±1 VDC
Maximum Cable Length	305 metres (1000 feet) with no degradation of signal, when used with 3500/46M

## Environmental Limits

Operating and storage temperature range	Maximum mounted surface temperature -40°C to +100°C (-40°F to +212°F)
Shock Survivability	981 m/s <sup>2</sup> (100g) peak
Relative Humidity	To 100% non-submerged; case is hermetically sealed.

## Physical

Weight (typical)	< 375grams (13.2oz)
Mounting	<a href="#">See "330505 System Dimensional Drawing" on page 7</a>

Case material	300 series stainless steel.
Connector	2-pin Mil-C-5015 receptacle, hermetically sealed, 300 series stainless steel.
Mounting Torque	46 kg cm (40 in-lb) max.
Polarity	Pin A becomes positive with respect to Pin B when the applied velocity is from the base to the top of the transducer.

## Compliance and Certifications

### FCC

This device complies with part 15 of the FCC Rules. Operation is subject to the following two conditions:

- This device may not cause harmful interference.
- This device must accept any interference received, including interference that may cause undesired operation.

### EMC

EMC Directive 2014/30/EU

### RoHS

RoHS Directive 2011/65/EU

## Ordering Information



For the detailed listing of country and product specific approvals, refer to the **Approvals Quick Reference Guide**, Document 108M1756, at [Bentley.com](http://Bentley.com).

### 330505-AA-BB-CC

#### A: Transducer Mounting Angle

0 1	0° ± 10°
0 2	90° ± 5°
0 3	180° ± 10°

#### B: Internal Mounting Thread

0 2	3/8-24 UNF-2B
-----	---------------

#### C: Mounting Adapter Option

0 0	No Adapter
0 1	1/2 - 20 UNF
0 2	M8 x 1
0 3	1/4 - 28 UNF
0 4	1/4 - 20 UNC
0 5	1/4 - 18 NPT
0 6	5/8 - 18 UNF
0 7	3/8 - 16 UNC

## Accessories

For more information, please refer to the 330505 Low Frequency Velocity Sensor User Guide (document 169873).

Part number	Description
89409-01	Individual 1/2 - 20 UNF mounting adapter.
89410-01	Individual M8 x 1 mounting adapter
89411-01	Individual 1/4 - 28 UNF mounting adapter
89412-01	Individual 1/4 - 20 UNC mounting adapter
89413-01	Individual 1/4 - 18 NPT mounting adapter
04300015	Individual 5/8 - 18 UNF mounting

	adapter.
161191	Individual 1/2 - 13 UNC mounting adapter

## Interconnection Cables

The following standard cable lengths are available. You can order custom cable lengths in increments of one foot at additional cost. Some cables have a minimum and maximum length. For details, see each part description below.

### Standard Cable Lengths

Feet	Meters (approximate)
6 ft	1.8 m
8 ft	2.4 m
10 ft	3.0 m
12 ft	3.6 m
15 ft	4.5 m
17 ft	5.0 m
20 ft	6.0 m
25 ft	7.6 m
30 ft	9.0 m
33 ft	10.0 m
50 ft	15.2 m
99 ft	30.0 m

## Cable Part Numbers

Part number	Description
† NOTE: Use 'AA' in the part numbers below to specify the length (in feet) of the cable you want to order.	
02173034	Splash-Proof Interconnect Cable  Recommended for high electromagnetic noise environment and European Conformance (CE).  Shielded 0.382 mm <sup>2</sup> (22 AWG) cable with a splash proof boot

330505 Low Frequency Velocity Sensor  
 Datasheet

Part number	Description
	over a female connector at the transducer end and flush cut at the monitor end. Temperature range -55 to 125°C (-67 to 257°F). See <a href="#">See "Graphs and Figures" on page 6.</a>
CB2W100-AAA+	<p>Splash-Proof Interconnect Cable</p> <p>Shielded 0.382 mm2 (22 AWG) cable with splash proof over molded boot, blunt cut at the monitor end. Temperature range -50 to 200°C (-58 to 392°F). See <a href="#">See "Graphs and Figures" on page 6.</a></p> <p>Standard lengths:</p> <p>01515 ft (4.5 m)</p> <p>03232 ft (9.8 m)</p> <p>06464 ft (19.5 m)</p> <p>112112 ft (34.1 m)</p> <p>125125 ft (38.1 m)</p> <p>150150 ft (45.7 m)</p> <p>200200 ft (61.09 m)</p>
9571-AA+	<p>Standard Interconnect Cable</p> <p>Shielded 0.382 mm2 (22 AWG) cable with a moisture resistant female connector at the transducer end and ring lugs at the monitor end. Temperature range -29 to 121°C (-20 to 250°F). See <a href="#">See "Graphs and Figures" on page 6.</a></p> <p>Minimum length 2 ft (0.60 m); maximum length 99 ft (30 m).</p>
84661-AA+	Standard Armored Interconnect Cable

Part number	Description
	<p>Stainless steel armor over shielded 0.382 mm2 (22 AWG) cable with a moisture resistant female connector at the transducer end and ring lugs at the monitor end. Temperature range -29 to 121°C (-20 to 250°F). See <a href="#">See "Graphs and Figures" on page 6.</a></p> <p>Minimum length 3 ft (0.91 m); maximum length 96 ft (29 m).</p>
89477-AA+	<p>Right Angle Interconnect Cable</p> <p>Shielded 0.963 mm2 (18 AWG) cable with a moisture resistant right angle female connector at the transducer end and ring lugs at the monitor end. Temperature range -29 to 121°C (-20 to 250°F). See <a href="#">See "Graphs and Figures" on page 6.</a></p> <p>Minimum length 2 ft (0.6 m); maximum length 99 ft (30 m).</p>
122129-AA+	<p>Short Run Interconnect Cable</p> <p>Shielded 0.963 mm2 (18 AWG) cable with a moisture resistant female connector at the transducer end and ring lugs at the monitor end. Temperature range -29 to 121°C (-20 to 250°F). See <a href="#">See "Graphs and Figures" on page 6.</a></p> <p>Minimum length 6 in (152 mm); maximum length 24 in (610mm).</p>
02173006	<p>0.963 mm2 (18 AWG) Bulk Cable</p> <p>Shielded twisted pair. Same cable</p>

330505 Low Frequency Velocity Sensor  
Datasheet

---

Part number	Description
	as used on 89477-AA and 122129-AA. Specify number of feet.
02173007	0.382 mm <sup>2</sup> (22 AWG) Bulk Cable  Shielded twisted pair. Same cable as used on 9571-AA and 84661-AA. Specify the number of feet. The maximum length that should be used with the transducer is 305 m (1000 ft)
00502025	Spare Connector  Same connector as used on 9571-AA and 84661-AA
101212-01	Right Angle Connector  Right angle connector kit. Same connector as used on 89477-AA.

## Graphs and Figures

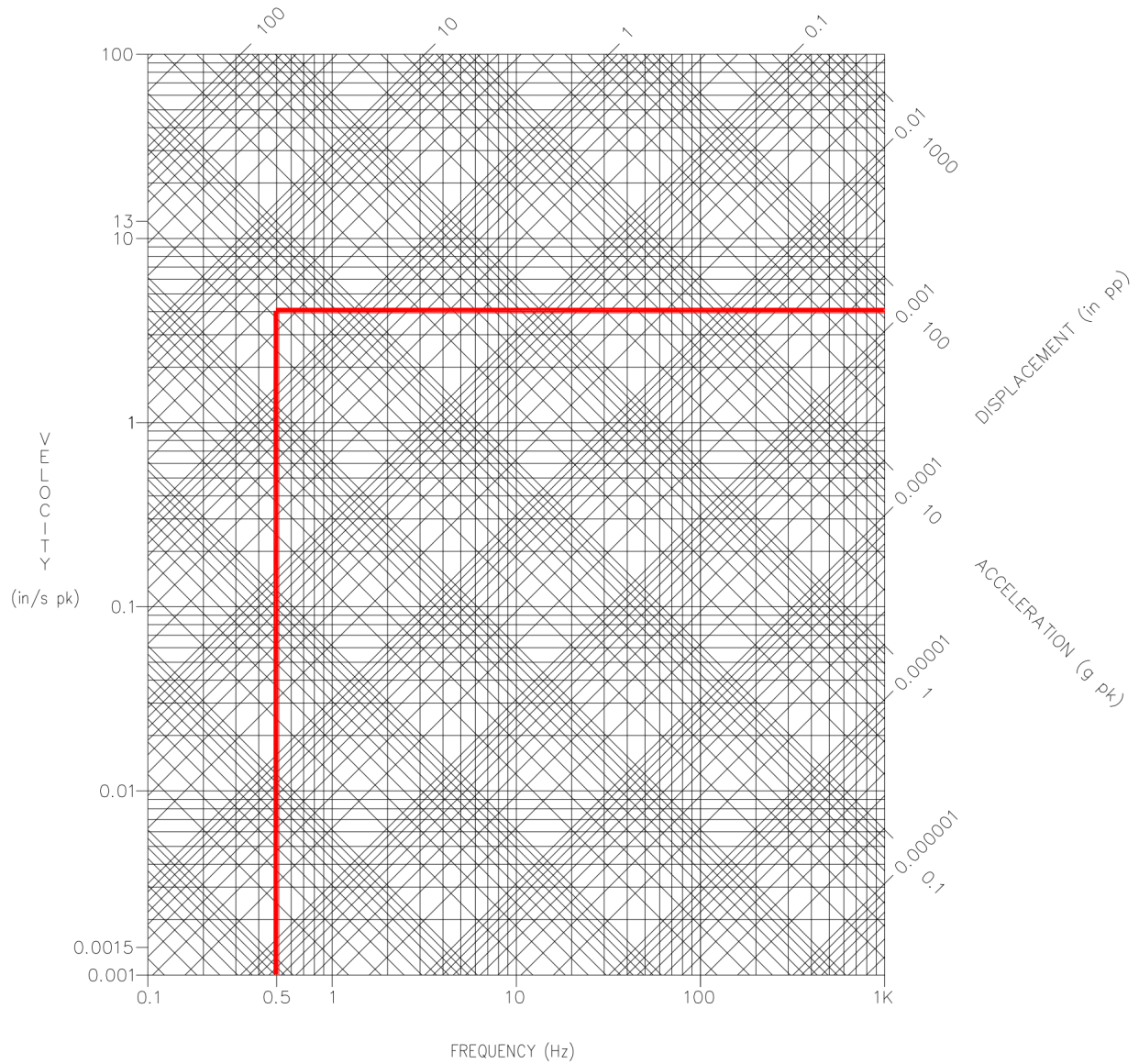

**Figure 1: 330505 Vibration Nomograph**

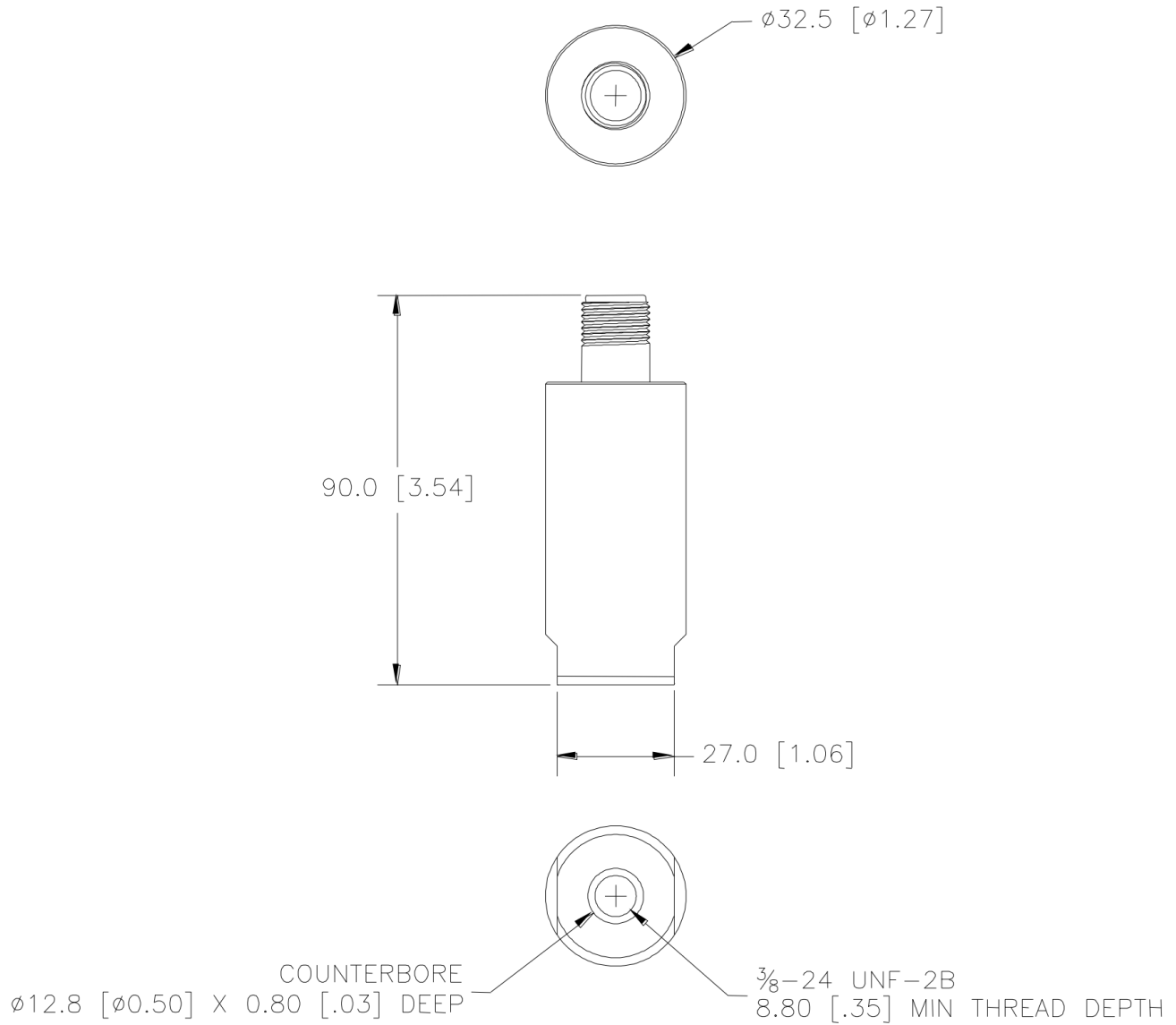

**Figure 2: 330505 System Dimensional Drawing**

(Dimensions are in millimeters [inches].)

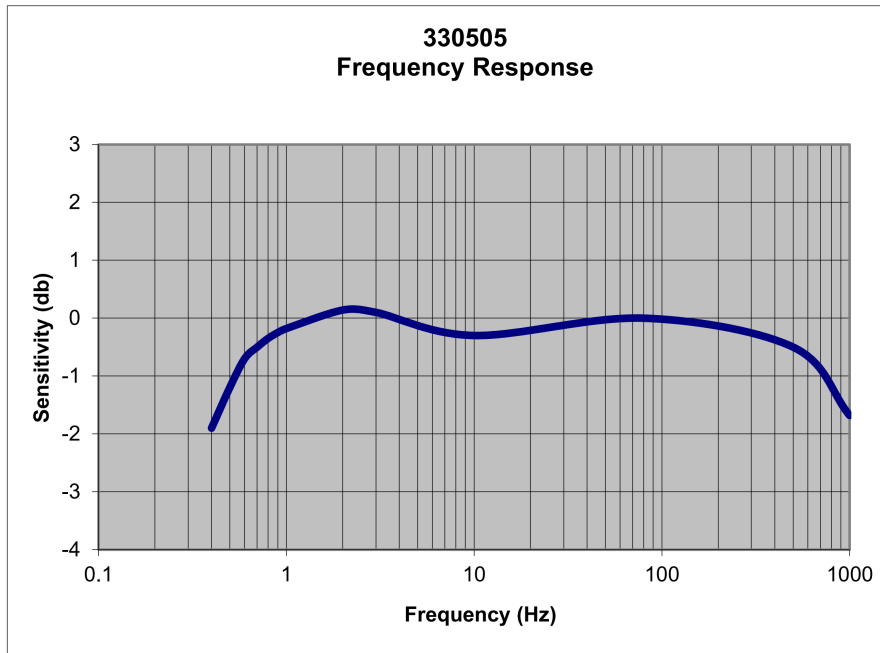

Figure 3: Typical Velocity Amplitude

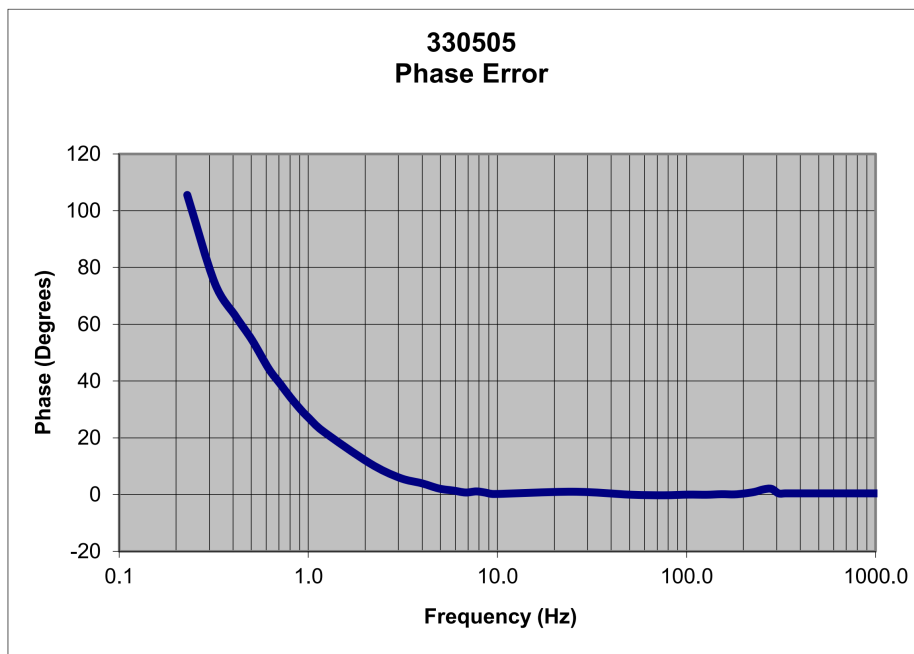
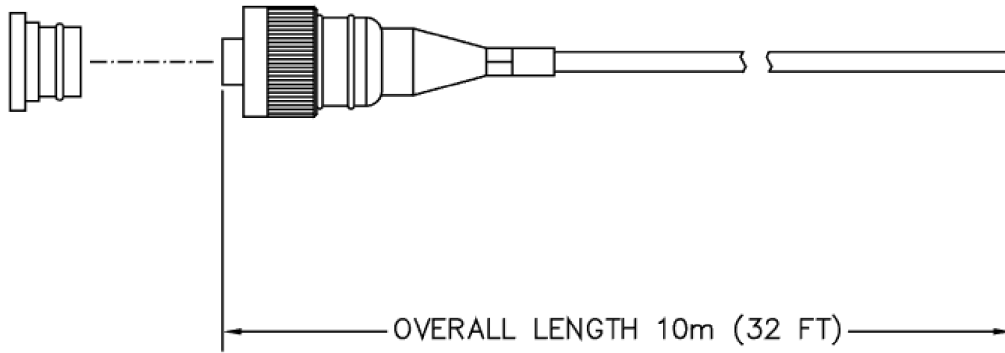
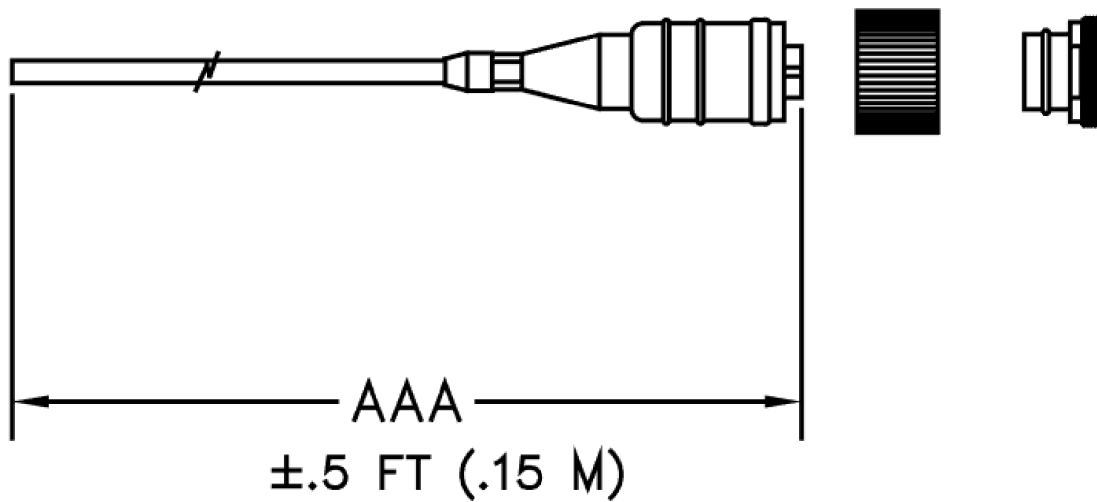

Figure 4: Typical Velocity Phase Error



**Figure 5: Splash-Prof Interconnect Cable**

(For available cable lengths and part numbers, [See "Interconnection Cables" on page 3](#))



**Figure 6: Splash-Proof Interconnect Cable**

(For available cable lengths and part numbers, [See "Interconnection Cables" on page 3](#))

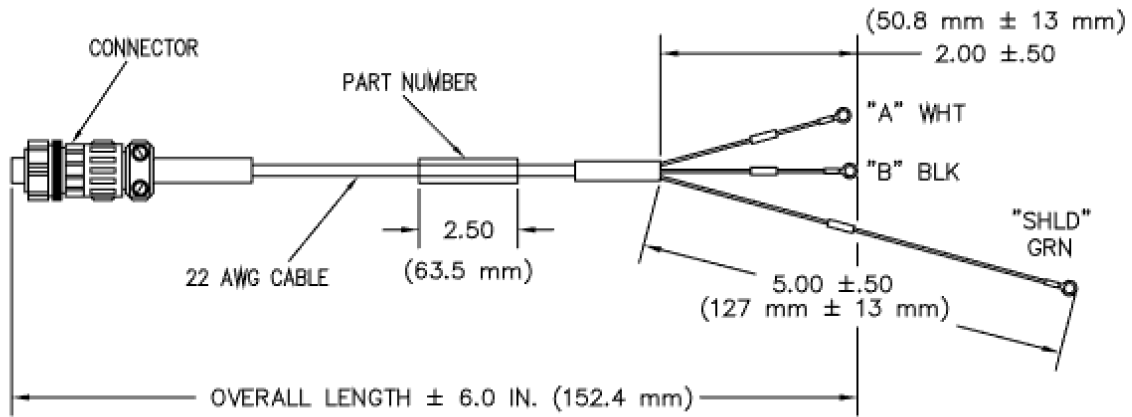

**Figure 7: Standard Interconnect Cable**

(For available cable lengths and part numbers, [See "Interconnection Cables" on page 3](#))

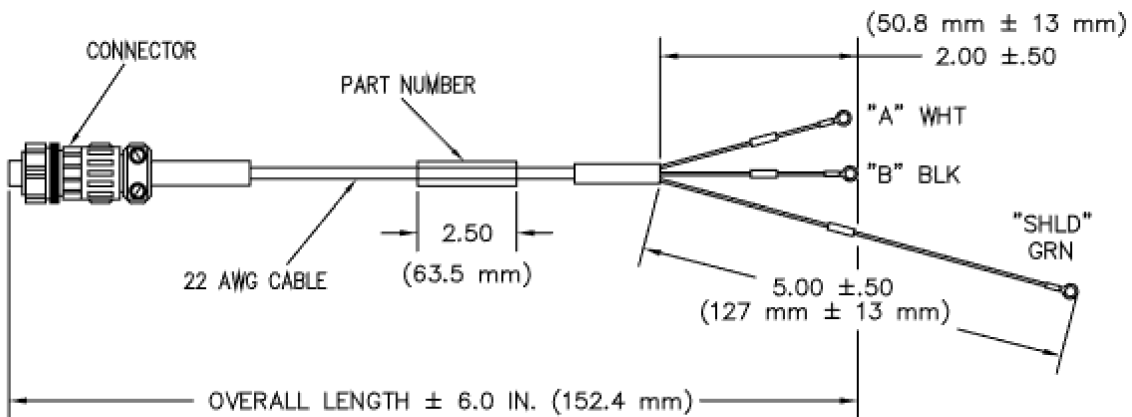

**Figure 8: Standard Armored Interconnect Cable**

(For available cable lengths and part numbers, [See "Interconnection Cables" on page 3](#))

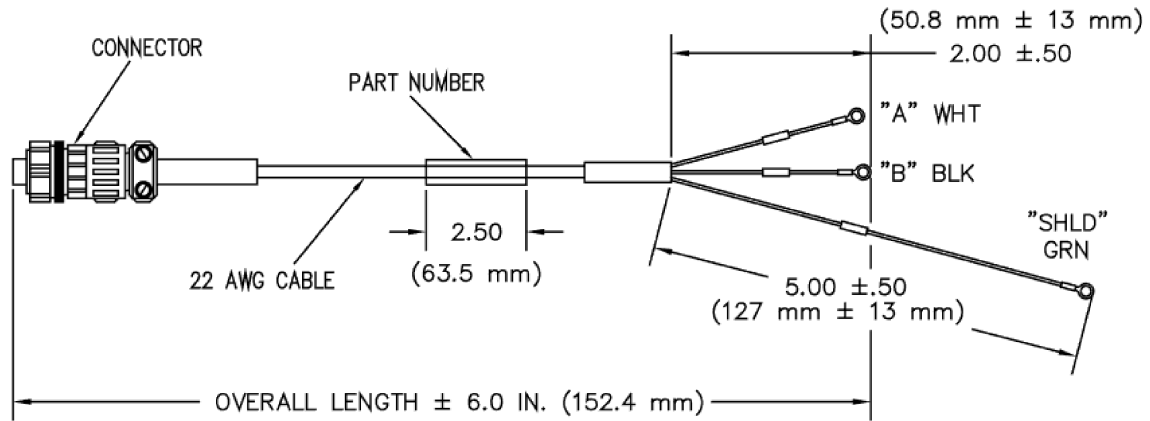

**Figure 9: Standard Armored Interconnect Cable**

(For available cable lengths and part numbers, [See "Interconnection Cables" on page 3](#))

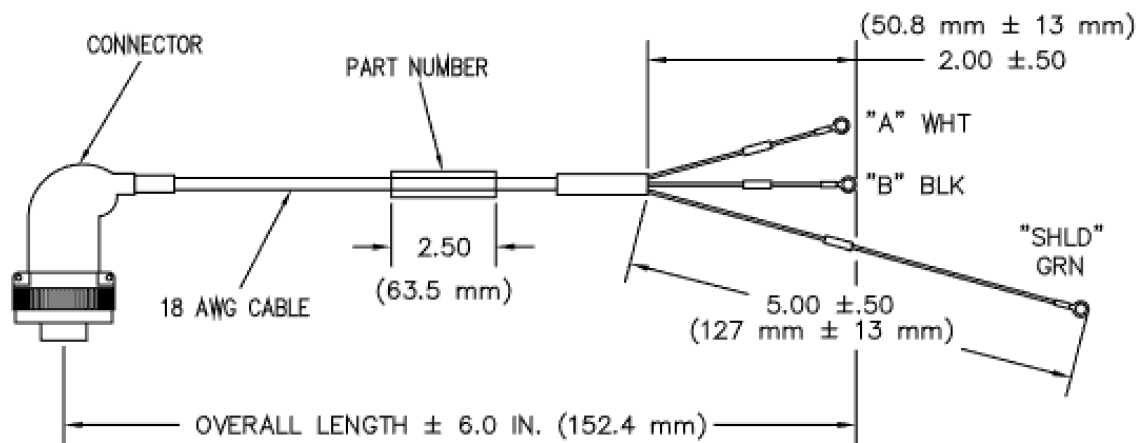

**Figure 10: Standard Right-Angle Interconnect Cable**

(For available cable lengths and part numbers, [See "Interconnection Cables" on page 3](#))

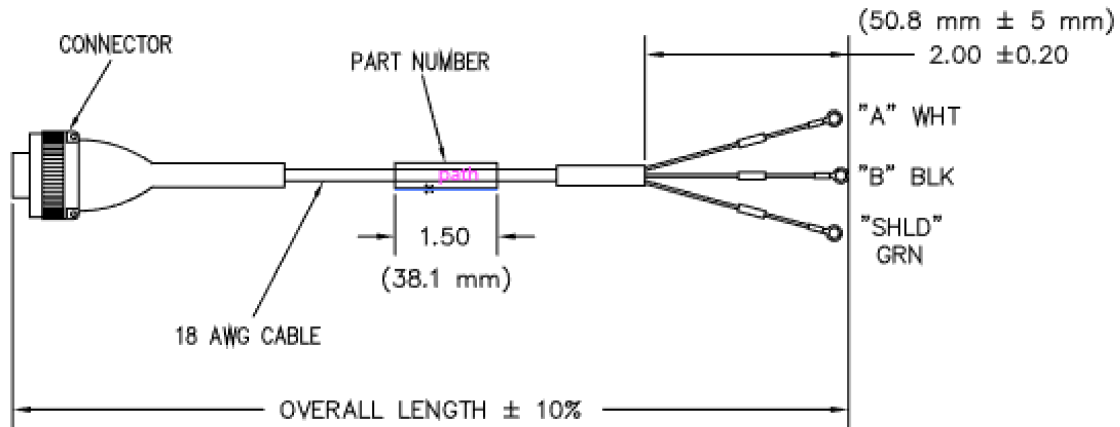

**Figure 11: Short Run Interconnect Cable**

(For available cable lengths and part numbers, [See "Interconnection Cables" on page 3](#))

Copyright 2019 Baker Hughes, a GE company, LLC ("BHGE") All rights reserved.

Bently Nevada and Orbit Logo are registered trademarks of BHGE in the United States and other countries. All product and company names are trademarks of their respective holders. Use of the trademarks does not imply any affiliation with or endorsement by the respective holders.

This product may be covered by one or more patents, see [Bently.com/legal](http://Bently.com/legal) for current status.

The information contained in this document is subject to change without prior notice.

1631 Bently Parkway South, Minden, Nevada USA 89423

Phone: 1.775.782.3611 [Bently.com](http://Bently.com)

