

TX100/200-SERIES



INSERTION TURBINE INSTRUCTIONS

TX100/200-SERIES INSERTION TURBINE INSTRUCTIONS



TX101/201



TX115/215

TABLE OF CONTENTS

General Information

Features, Specifications Page 1

Installation

Piping, Immersion, Positioning the Meter Page 2

Straight Pipe Recommendations Page 3

Full Pipe Recommendations Page 4

Fitting Installation, Meter Installation Page 5

Proper Depth Setting, Dimension C, Pipe Wall Thickness Page 6

Set-Up

Connection, Calibration, K-Factors Page 7

Operation

Flow Range, Flow Rates Page 8

Parts List

Parts Exploded View Page 9

Troubleshooting & Repair

Troubleshooting, Repair, Rotor Replacement Back

TABLES AND DIAGRAMS

Features Page 1

Specifications Page 1

Positioning the Meter Page 2

Piping Page 2

Straight Pipe Recommendations Page 3

Full Pipe Recommendations Page 4

Meter Installation Page 5

Depth Setting Page 6

Dimension "C" Page 6

Pipe Wall Thickness Page 6

Connection Diagram Page 7

K-Factor Table Page 7

Parts Exploded View Page 9

Parts List Page 9

Rotor Replacement Back

GENERAL INFORMATION

The TX100/200-Series are adjustable depth insertion turbines that come in brass or 316 stainless models to fit 3" to 48" pipe. Installation fittings are standard 1-1/2" (101/201) or 2" (115/215) FNPT. Fittings such as saddles and weldlets may be purchased either locally or from Seametrics.

Ruby bearings and a non-drag pickoff give these adjustable insertion turbine flow sensors a wide flow range and long life. A sensor detects the passage of miniature magnets in the rotor blades. The resulting square-wave signal can be sent for hundreds of feet without a transmitter, over unshielded cable. This signal can be connected directly to many PLC's and other controls without any additional electronics.

FEATURES

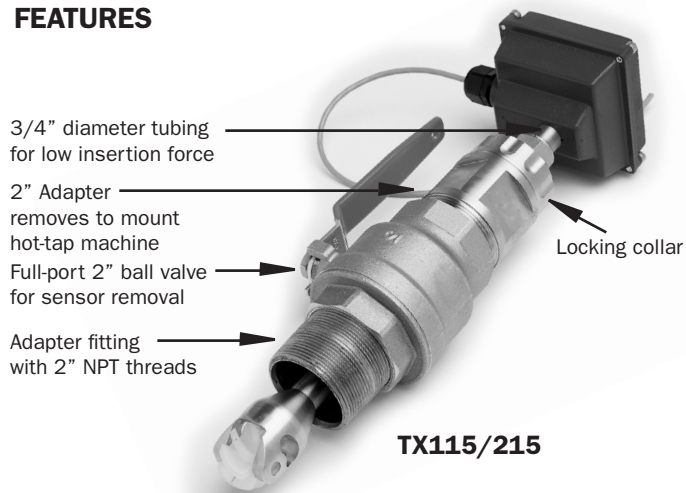

If desired, a modular system of electronics can be installed directly on the flow sensor or mounted remotely. The FT415 (battery powered) or FT420 (loop powered) provides digital rate and total display, as well as programmable pulse; the FT420 also provides a 4-20 mA analog output. The AO55 is a blind analog (4-20 mA) transmitter. Programmable pulse for pump pacing is available with the PD10.

The "hot-tap" models (TX115/215) can be installed or serviced without shutting down the line by means of a 2" full-port isolation valve that comes with a nipple for installation on the pipe fitting. In most circumstances, no special tool is required.

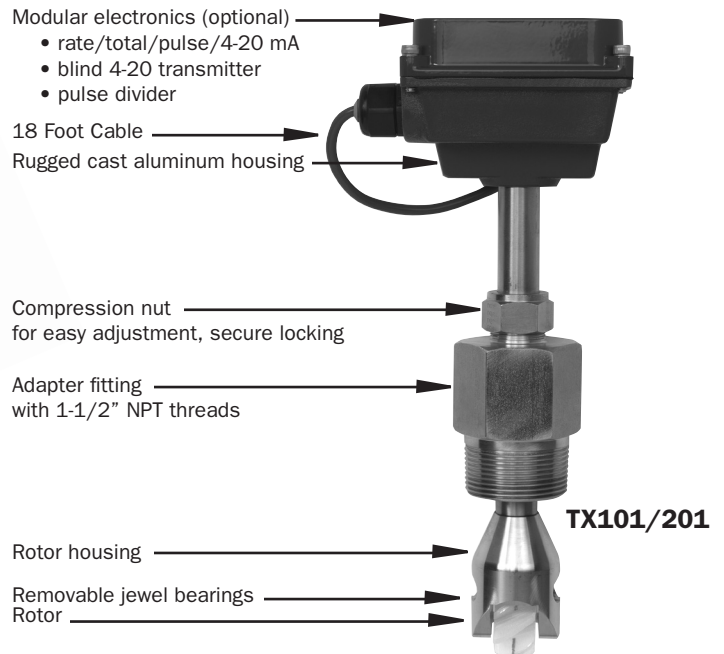

SPECIFICATIONS*

Power Source		Standard	Micropowered (-04 Option)
Supply Voltage/Current		6-40 Vdc/< 2 mA	3.5-16 Vdc/60 µA @ 3.5 Vdc
Sensor	Type	Magneto-resistive	Magneto-resistive
	Output	Current Sinking Pulse	Current Sinking Pulse
	Sinking Current	100 mA max	2 mA max
	External Pull-up Resistor	3-40 Vdc	≤ Supply Voltage
Pipe Size		TX101/115	TX201/215
		3" - 10" (50 - 250mm)	10" - 48" (250 - 1200mm)
Materials	Housing	Cast aluminum	
	Sensor Body	Brass or 316 SS	
	Rotor	Polypro standard (PVDF optional)	
	Shaft/Bearings	Nickel-bound tungsten carbide/Ruby	
	Isolation Valve	TX101/201	TX115/215
		None	Bronze (316SS optional)
Fitting Size		1-1/2" NPT	2" NPT
Flow Range		0.2 - 30 feet/sec (0.006 - 9 meter/sec)	
Accuracy		+/-1.5% of full scale	
Maximum Temperature		200° F (93° C)	
Maximum Pressure		200 psi (14 bar)	
Insertion Force		0.44 x pressure in pipe	
Cable		#22 AWG 3-con, 18' (6m); 2,000' (650m) maximum cable run	
Regulatory		CE Mark (Standard Power Only)	

*Specifications subject to change. Please consult our website for the most current data (www.seametrics.com).

INSTALLATION

An insertion flow sensor measures the velocity of flow at one point in the pipe; flow rate and total can be inferred from this one point. Accuracy is decreased by any factor which makes the flow at the measured point unrepresentative of the entire flow stream. This includes distorted flow patterns caused by upstream fittings too close to the sensor. The worst offenders are fittings that increase the flow on one side of the pipe, such as partially-opened gate or butterfly valves. Fluid moving in a pipe does not flow at the same velocity. Toward the center of the pipe, fluid moves faster than at the wall, and the relationship between the two changes as overall flow rate increases. This change in the “velocity profile” can result in non-linearity, which means that the K-factor (see page 7) that is correct for one flow rate may be incorrect for another. Recommended depth settings (see page 6) have been carefully chosen to minimize this source of error, and should be followed carefully, especially in the smaller pipe sizes.

Piping. For best results, the TX sensor should be installed with at least ten diameters of straight pipe upstream and five downstream. Certain extreme situations such as partially-opened valves are particularly difficult and may require more straight diameters upstream. See Straight Pipe and Full Pipe recommendations on following pages.

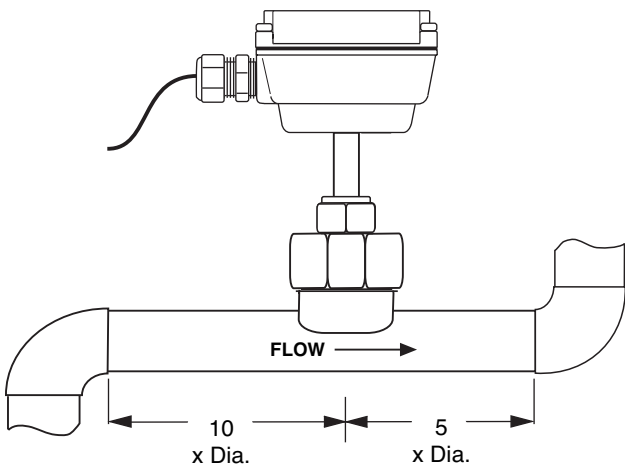

Immersion. The TX100/200-Series standard sensors are not designed for continuous underwater operation. If your meter may experience occasional temporary immersion, as in a flooded vault, a unit modified for immersion should be specified (Option -40).

Positioning the Meter. Horizontal is the preferred installation orientation, since it improves low-flow performance slightly and avoids problems with trapped air. Bottom, top, and vertical pipe installations are all acceptable if required by the piping layout.

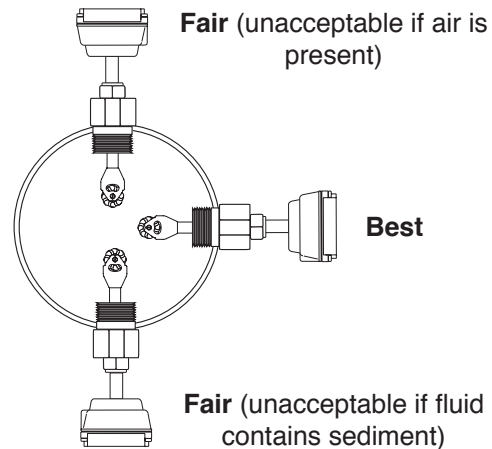



CAUTION: These water meters are not recommended for installation downstream of the boiler feedwater pump where installation fault may expose the meter to boiler pressure and temperature. Maximum recommended temperature is 200°F.

INSTALLATION

STRAIGHT PIPE RECOMMENDATIONS

(X = diameter)

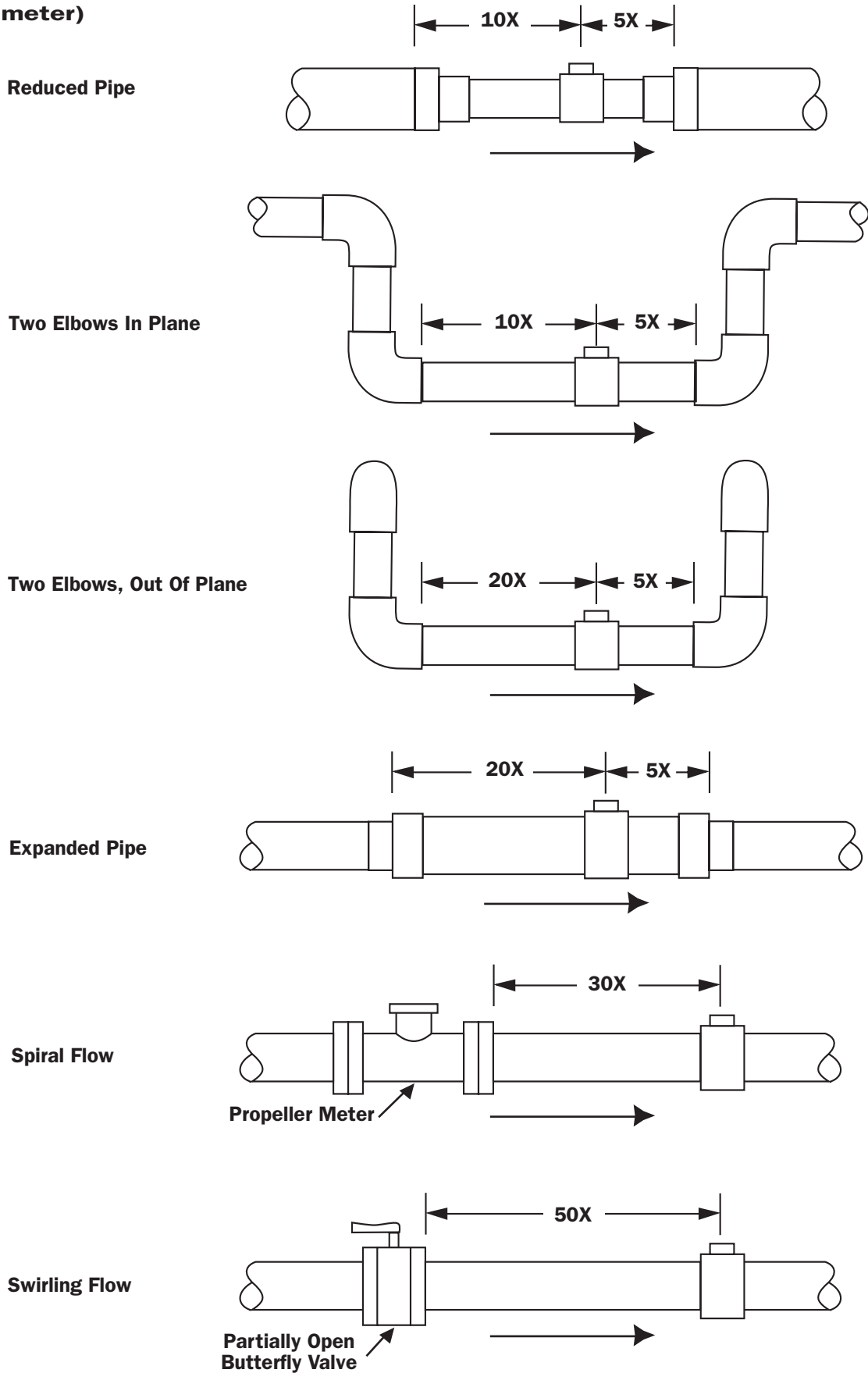

INSTALLATION

FULL PIPE RECOMMENDATIONS

Possible Problem

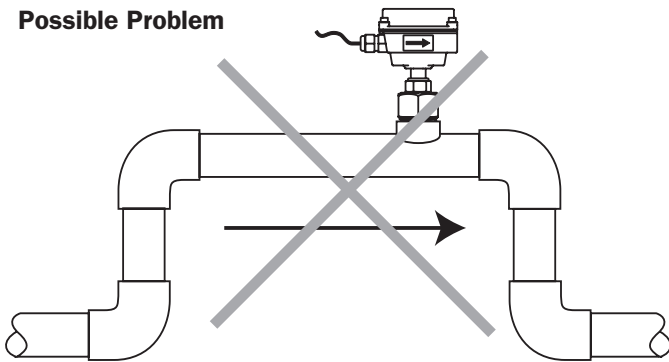

Allows air pockets to form at sensor

Better Installation

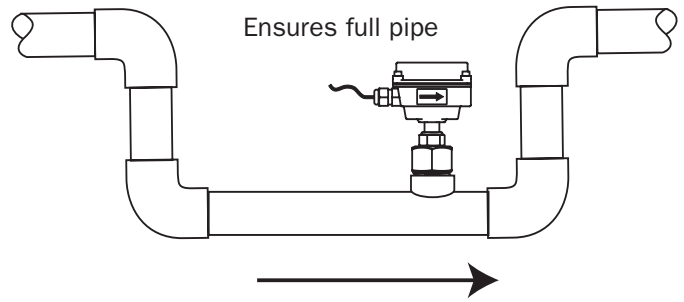

Possible Problem

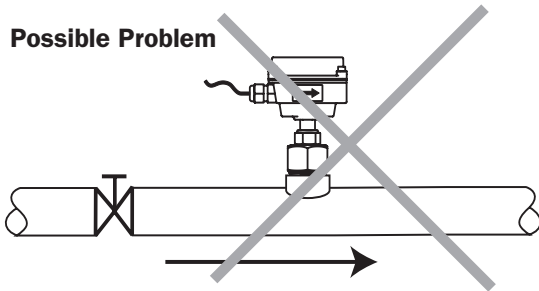

Post-valve cavitation can create air pocket

Better Installation

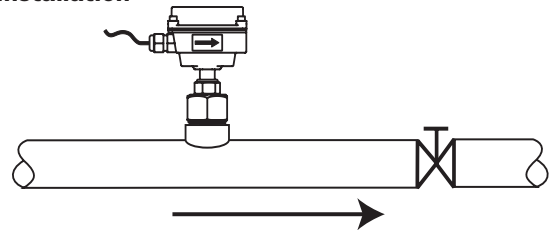

Keeps pipe full at sensor

Possible Problem

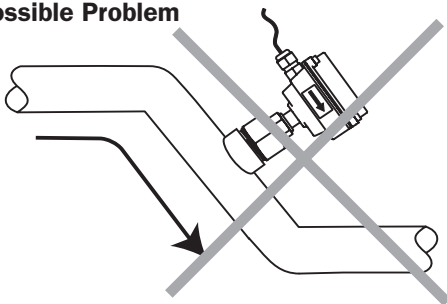

Air can be trapped

Better Installation

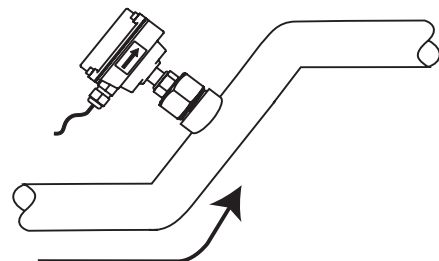

Allows air to bleed off

INSTALLATION

TX101/201 INSTALLATION

Fitting Installation. TX101/201 sensors come with a 1-1/2" male NPT pipe thread adapter fitting. Any fitting that provides the matching NPT female thread may be used. Installation procedure compensates for fitting height differences. Cut a minimum 1-3/4" hole in the pipe. If possible, measure the wall thickness and write it down for use in depth setting. Then install the threaded fitting (saddle, weldolet, etc.) on the pipe.

Meter Installation. Loosen the compression nut so that the adapter slides freely. Pull the meter fully upward and finger-tighten the compression nut. Using a thread sealant, install the adapter in the pipe fitting. Do not overtighten. Now loosen the compression nut, lower the meter to the appropriate depth setting (see diagram and instructions that follow). Be sure flow is in the direction of the arrow on the housing. Tighten compression nut fully.

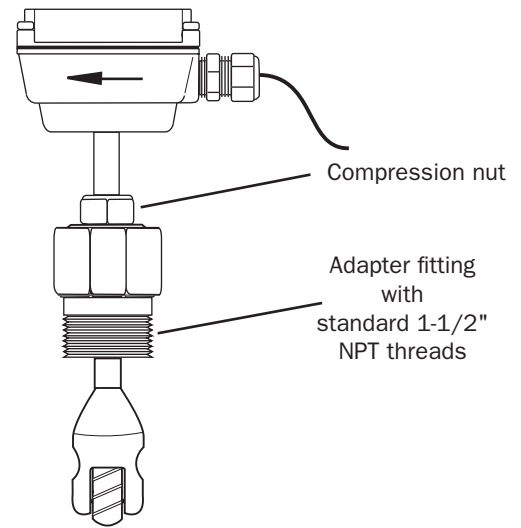

TX115/215 INSTALLATION

'Hot tap' TX meters are designed to be installed and serviced without depressurizing the pipe.

Fitting Installation. The TX115/215 sensors have a 2" NPT thread for compatibility with the 2" isolation valve. Any fitting that provides matching NPT female thread may be used. The installation procedure compensates for differences in fitting height.

If initial installation is performed on an unpressurized pipe, cut a minimum 1-3/4" hole in the pipe. If possible, measure the wall thickness and write it down for use in depth setting. Then install the threaded fitting (saddle, weldolet, etc.) on the pipe.

If it is necessary to do the initial installation under pressure, any standard hot tap drilling machine with 2" NPT adapter, such as a Transmate or a Mueller, can be used. Ordinarily, it is not necessary to use an installation tool, since the small-diameter tube can be controlled by hand at all but the highest pressures.

Meter Installation. Remove the sensor unit from the valve assembly. Using a thread sealant, install the valve assembly on the pipe fitting. If the initial installation is a pressure ("hot") tap, remove the 1-1/2" x 2" adapter bushing at the back of the valve. Thread the tapping machine on, open the valve, and tap using a minimum of 1-3/4" or maximum 1-7/8" cutter. After retracting the machine and closing the valve, reinstall the flow sensor. When the sensor is secure, open the valve and adjust depth setting (see diagram and instructions that follow). Be sure flow is in the direction of the arrow on the housing. Tighten locking collar and compression nut fully.

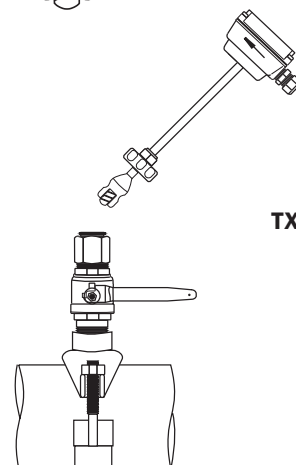
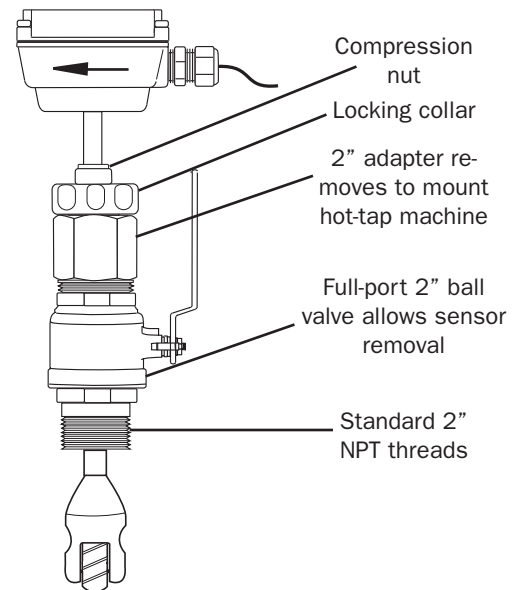

INSTALLATION

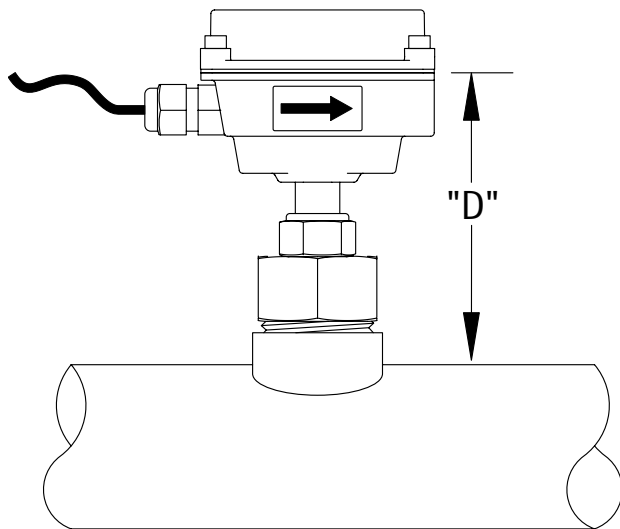

Proper Depth Setting. It is important for accuracy that the sensor be inserted to the correct depth into the pipe.

1. In Table 1, find Dimension C for your sensor model and pipe size. Subtract wall thickness of your pipe (Table 2) to calculate Dimension D.
2. Measuring from the outside of the pipe to the joint in the housing, as shown, adjust the sensor to Dimension D and hand-tighten compression nut.
3. Align the conduit housing with the centerline of the pipe, as shown below. Be sure the arrow on the housing points in the direction of flow.

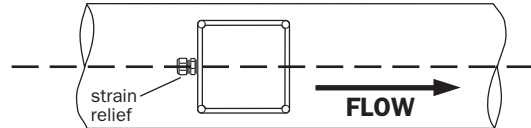

4. Check Dimension D one more time.
5. Tighten the compression nut fully.

TABLE 1: DIMENSION "C"

	NOMINAL PIPE SIZE												
	3"	4"	6"	8"	10"	12"	14"	16"	18"	20"	24"	30"	36"
TX101	9.16	9.08	8.99	8.82	8.48	8.14	7.80	7.46	6.78	-	-	-	-
TX201	14.16	14.08	13.99	13.82	13.48	13.14	12.80	12.46	11.78	10.42	9.40	9.38	-
TX115	16.00	15.80	15.70	15.50	15.10	14.80	14.50	13.80	-	-	-	-	-
TX215	19.95	19.85	19.65	19.45	19.15	18.85	18.45	17.75	16.45	15.45	14.35	-	-

TABLE 2: PIPE WALL THICKNESS

	NOMINAL PIPE SIZE												
	3"	4"	6"	8"	10"	12"	14"	16"	18"	20"	24"	30"	36"
PVC/Steel Sch. 40	0.216	0.237	0.280	0.322	0.365	0.406	0.438	0.500	0.562	0.593	0.687		
PVC/Steel Sch. 80	0.300	0.337	0.432	0.500	0.593	0.687	0.750	0.843	0.937	1.031	1.218		
Stainless Steel (10S)	0.120	0.120	0.134	0.148	0.165	0.180	0.188	0.188	0.188	0.218	0.250	0.312	0.312
Stainless Steel (40S)	0.216	0.237	0.280	0.322	0.365	0.375	0.375	0.375	0.375	0.375	0.375	0.375	0.375
Copper Tubing (Type L)	0.090	0.110	0.140	0.200	0.250	0.280							
Copper Tubing (Type K)	0.109	0.134	0.192	0.271	0.338	0.405							
Brass Pipe	0.219	0.250	0.250	0.312	0.365	0.375							
Duct. Iron (Class 52)	0.280	0.290	0.310	0.330	0.350	0.370	0.390	0.400	0.410	0.420	0.440	0.470	0.530

SET-UP

Connection. Sensors are supplied with 18 ft. of cable. For sensors with no additional electronics, see diagram for color coding. For sensors with on-board electronics, see the manual accompanying the electronics module.

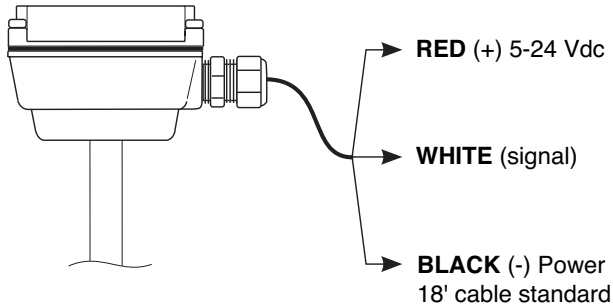

Calibration (“K-Factor”). In order to properly process pulses from the flow sensor, a number must be entered into the control to which the sensor is connected. This number, called the K-factor, is the number of pulses the sensor puts out per unit of fluid passing through the pipe. It is normally provided for Seametrics sensors in pulses per gallon (see Table 3, below). These numbers are based on extensive testing, which has shown close agreement between different TX sensors in the same installation. Most K-factor error can be attributed to installation variables, such as depth setting and fitting configuration.

It is possible to field calibrate a sensor by catching the fluid in a measured container and comparing with the number of pulses recorded. (To record individual pulses, set the K-factor on the control to 1.00.) This is especially desirable if the installation has less than the recommended length of straight pipe upstream of the sensor. For detailed instructions on field calibration, please refer to the technical bulletin on our website (www.seametrics.com/pdf/LT-13276-A.pdf).

TABLE 3: TX100/200 K-factors (in Pulses/Gallon) for various pipe sizes

	Nominal pipe size												
	3"	4"	5"	6"	8"	10"	12"	16"	24"	30"	36"	38"	42"
PVC/Steel Sch. 40	17.41	10.11	6.43	4.45	2.13	1.35	0.951	0.602	0.258	0.158	0.110	0.098	0.080
PVC/Steel Sch. 80	19.49	11.19	7.07	4.08	2.33	1.48	1.05	0.660	—	—	—	—	—
Stainless Steel (10S)	15.42	9.03	5.84	4.06	1.95	1.25	0.880	—	—	—	—	—	—
Stainless Steel (40S)	17.41	10.11	6.43	4.45	2.13	1.35	0.951	—	—	—	—	—	—
Stainless Steel (80S)	19.49	11.19	7.07	4.08	2.33	1.48	—	—	—	—	—	—	—
Copper Tubing (Type K)	19.39	10.91	7.10	4.11	2.36	—	—	—	—	—	—	—	—
Copper Tubing (Type L)	18.89	10.75	6.90	3.97	—	—	—	—	—	—	—	—	—
Copper Pipe	17.48	10.24	6.39	3.61	2.12	—	—	—	—	—	—	—	—
Duct. Iron (Class 52)	15.61	9.20	—	3.43	1.92	1.25	0.87	0.49	—	—	—	—	—

OPERATION

Flow Range. These sensors are designed to operate at flow velocities of 0.2 to 30 feet per second (see Table 4, below). If erratic readings are encountered at low flows, check the chart to see if flow is below minimum for the pipe size. The standard shaft and bearings should have a long life at continuous high flow.

TABLE 4: Flow Rates converted from Feet/Sec to Gallons/Minute at various velocities: Schedule 40 pipe

Feet / Sec ▼	Nominal pipe size											
	3"	4"	5"	6"	8"	10"	12"	16"	24"	36"	38"	48"
(0.2)	4.6	7.9	12.5	18	31.2	49.1	70	125	259	600	670	1090
(0.5)	11.5	19.8	31.2	45	78	123	174	275	627	1460	1770	2820
(1.0)	23	39.7	62.4	90	156	246	349	551	1250	2910	3530	5640
(2.0)	46.1	79.4	125	180	312	492	698	1100	2510	5830	7070	11280
(5.0)	115	198	312	450	780	1230	1740	2750	6270	14570	17670	28200
(10.0)	230	397	624	900	1560	2460	3490	5510	12530	29140	35350	56400
(20.0)	461	794	1250	1800	3120	4920	6980	11020	25060	58270	70700	112800
(30.0)	691	1190	1870	2700	4680	7370	10470	16520	37600	87410	106050	170000

PARTS LIST

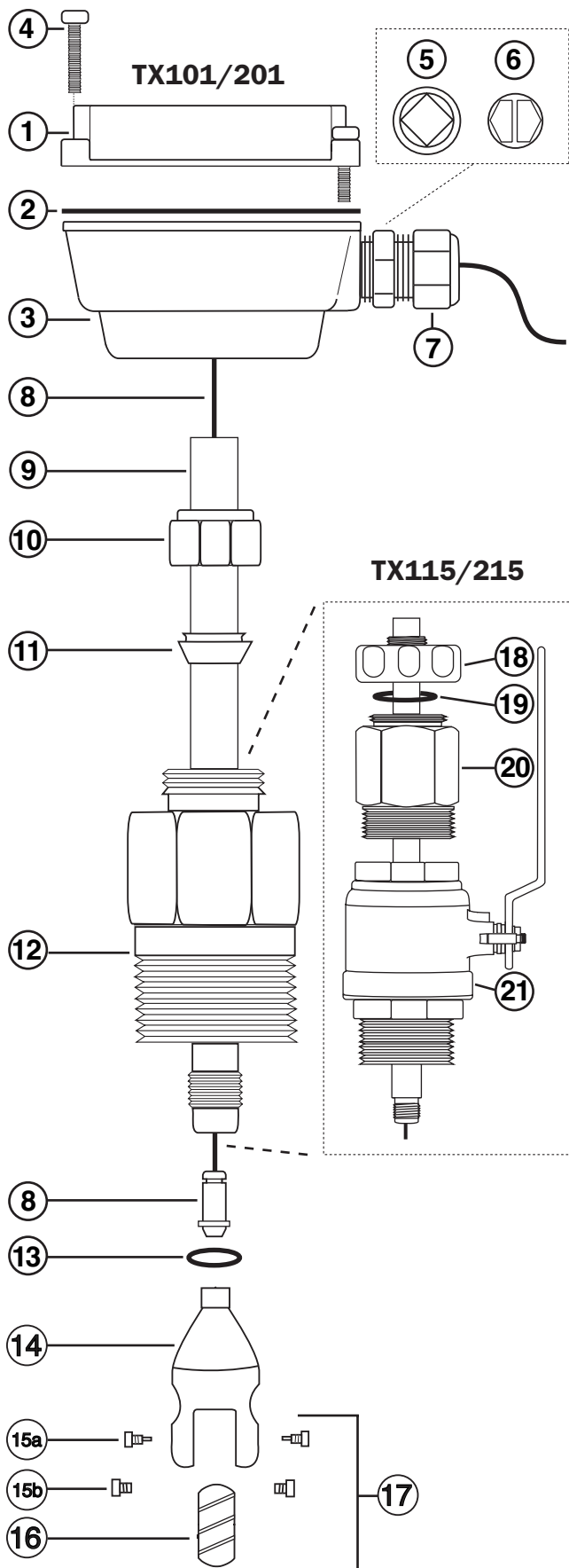

TX 101/201 Parts		
1	Upper housing assembly	30475
2	Housing Gasket	26211
3	Lower housing	Not Field Replaceable
4	Housing screw assembly	26229 (4 required)
5	Plug, steel	26073
6	Plug, plastic	26079
7	Strain relief	07655
8	Sensor w/cable	26310 (Standard - FT420) 29953 (Micropower - FT415)
9	Tube	Not Field Replaceable
10	Compression nut	14199 (Brass) 15064 (S/S)
11	Compression Ferrule	26065
12	Adapter fitting	30998 (Brass) 30999 (S/S)
13	Rotor housing O-ring	16454
14	Rotor housing	25977 (Brass) 25978 (S/S)
15a	Jewel bearing assembly (for carbide shaft) or	25901 (2 req'd)
15b	Shaft holder (for ceramic shaft)	16710 (2 req'd)
16	Turbine Rotor assembly	25946 (Polypro/Carbide) 25947 (Kynar/Ceramic)
17	Rotor repair kit (consists of #15 & #16)	25930 (Polypro/Carbide) 25945 (Kynar/Ceramic)

TX 115/215 Parts (hot tap)		
All part numbers are the same except those below		
18	Locking Collar	14190 (Brass) 15070 (S/S)
19	Adapter fitting O-ring	26029
20	Adapter, hot tap	26130 (Brass) 26131 (S/S)
21	Valve assembly (includes Adapter, #20)	14225 (Brass) 15225 (S/S)

Troubleshooting



CAUTION! Never attempt to remove a flow sensor when there is pressure in the pipe. Loosen the compression nut slowly to release any trapped pressure. If fluid sprays out when removing the sensor, stop turning and depressurize the pipe. Failure to do so could result in the sensor being thrown from the pipe, resulting in damage or serious injury.

The flow sensor has only one moving part, the rotor. If this is turning properly and there is no signal, the Hall-effect sensor is not operating properly. To check the signal, apply 12 Vdc regulated* power to the red (+) and black (-) leads. Set a multimeter to voltage reading. Put the positive multimeter lead on the red wire and the negative lead on the white wire. Slowly turn the rotor. Voltage reading should swing between +12 Volts and 0 Volts as the rotor turns. If it does not, the Hall effect sensor is not working properly. Checking for continuity is not a useful test of these sensors.

*NOTE: An unregulated power supply can exceed max voltage of micro powered sensor (gray cable) and damage sensor.

Repair

All Seametrics flow sensors are repairable, and can be returned to the factory or distributor for repair.

Please first obtain a Return Material Authorization (RMA) number.

Rotor Replacement.* Rotors are easily field-replaced. Shaft and rotor are a single unit, and are not replaced separately. If replacement is due only to normal shaft wear, bearing replacement is probably not necessary. If the rotor has been damaged by impact, the bearings should also be replaced. Rotor and bearings can be ordered as a kit (see parts listing). Follow these steps:

1. Unscrew the threaded bearing housings to expose the shaft ends. If bearings are being replaced, back them completely out.
2. Remove the rotor. Put the new rotor in its place.
3. Thread in one bearing housing part way, then the other. Take care to start the end of the shaft into the bearing hole before tightening further.
4. Screw in bearing housings until they bottom.
Note: Do not use excessive force.
5. Check for free spin. Blowing lightly on the rotor should result in it spinning rapidly and coasting to a smooth stop.

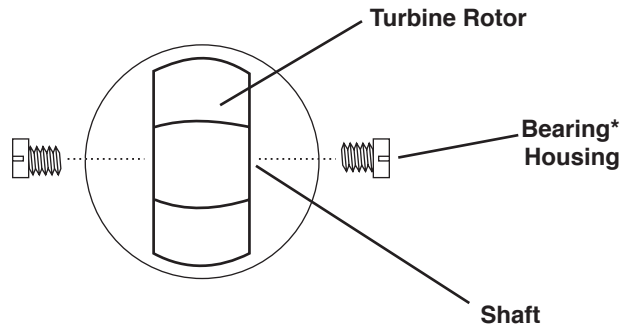

*NOTE: Described here is the rotor/shaft/bearing configuration for the carbide shaft model. On ceramic shaft models the shafts are in the screws and the bearings are in the rotor. Follow the same basic procedure above.

