

AST4500 & AST4510 *Submersible* Stainless Steel Media Isolated Pressure Sensor



BENEFITS

- ◆ High Strength Stainless Steel Construction
- ◆ No Internal O-rings
- ◆ Wide Operating Temperature Range
- ◆ Ranges up to 100 PSI
- ◆ Low Static and Thermal Errors
- ◆ Unparalleled Price and Performance
- ◆ Rugged Design Survives Harsh Environments
- ◆ Compatible with Wide Range of Liquids
- ◆ EMI/RFI Protection

APPLICATIONS

- ◆ Ground Water Level Depth Measurement
- ◆ Earthen & Concrete Dams
- ◆ Liquid Level Tanks
- ◆ Gasoline & Diesel Fuel Tanks
- ◆ Irrigation
- ◆ Waste Water Canals



TTI Instruments

www.ttiglobal.com • 1-800-235-8367

8 Leroy Road, PO Box 1073 Williston, VT 05495

Phone: (802) 863-0085 Fax: (802) 863-1193

Email: sales@ttiglobal.com

Performance @ 25°C (77°F)

Accuracy*	< ± 0.25% BFSL
Stability (1 year)	±0.25%FS, typ
Over range Protection	2X Rated Pressure
Burst Pressure	5X or 1,250 psi (whichever is less)
Pressure Cycles	>50 Million

*Accuracy includes: Non-linearity, Hysteresis and Non-repeatability

Environmental Data

Temperature

Operating	-40 to 85°C (-40 to 185°F)
Storage	-40 to 100°C (-40 to 212°F)

Thermal Limits

Compensated Range	0 to 55°C (30 to 130°F)
TC Zero	<±1.5% of FS
TC Span	<±1.5% of FS

Other

Shock	100G, 11 msec, 1/2 sine
Vibration	10G peak, 20 to 2000 Hz.
EMI/RFI Protection:	Yes
Rating:	IP-68

Electrical Data

Output	4-20mA	1-5VDC
Excitation	10-28VDC	10-28VDC
Output Impedance	>10k Ohms	<100 Ohms, Nominal
Current Consumption:	20mA, typ.	<10mA
Bandwidth	(-3dB): DC to 250 Hz	(-3dB): DC to 1kHz
Output Noise:	-	<2mV RMS
Zero Offset:	<±1% of FS	<±1% of FS
Span Tolerance:	<±2% of FS	<±2% of FS
Output Load:	0 Ohms @10V 800 Ohms @28V	10k Ohms, Min.
Reverse Polarity Protection	Yes	Yes

Physical Description

Wetted Material	Stainless Steel (Sensor), Hytrel (cable) (for other materials, consult factory)
Electrical Connection	6 feet vented cable (for other lengths, consult factory)
Case (housing)	304 stainless steel (for other materials, consult factory)

Warranty

Workmanship - AST, Inc. pressure transmitters have a limited one-year warranty to the original purchaser. AST, Inc. will replace or repair, free of charge, any defective transmitter. This warranty does not apply to any units that have been modified; misused, neglected or installed where the application exceeds published ratings. AST4510 not recommended for use with hydrogen.

Installation/Applications - The purchaser is responsible for media compatibility, functional adequacy, and correct installation of the transmitter.

AST's sensors are made with pride in New Jersey, USA. If in the area please feel free to stop by for a visit!

Ordering information

AST4500 **L** **00005** **P** **4** **C** **1** **000**

Series Type

Configuration Interface
L = Cone

Pressure Range
Insert pressure range from chart

Pressure Unit
B = Bar
H = Inches H₂O
K = kg/cm²
P = PSI

Outputs
1 = 0.5-4.5V ratiometric
3 = 1-5V
4 = 4-20mA

Electrical
C = 6Ft Cable (1.8m)
D = 10Ft Cable (3m)
X = Optional Length (see options)

Wetted Material
1 = 316L
Hytre

Options Cable Lengths*:
140 = 15Ft (4.6m) 130 = 40Ft (12.2m)
075 = 20Ft (6.1m) 065 = 50Ft (15.2m)
074 = 25Ft (7.6m) 003 = 100Ft (30.5m)
004 = 35Ft (10.7m) 050 = 150Ft (45.7m)

*Other cable options available, please consult factory.

Pressure Ranges*

AST4500

Gage PSIG	Pressure Range Code
0-100	00100
0-50	00050
0-30	00030
0-20	00020

AST4510

Gage PSIG	Pressure Range Code
0-15	00015
0-10	00010
0-7.5	00208**
0-5	00005

**7.5 PSI Sensor must be ordered in inches of H₂O.
*Typical Ranges. All ranges between 0-15 PSI and 0-100 PSI are available. Please consult factory.

Dimensional Data

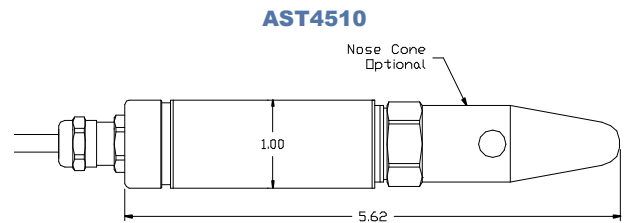
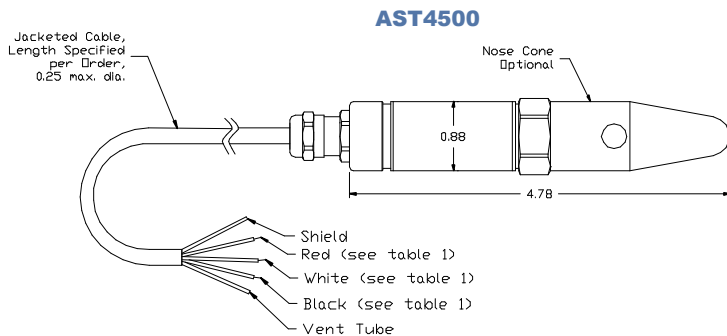

Barrier Installation

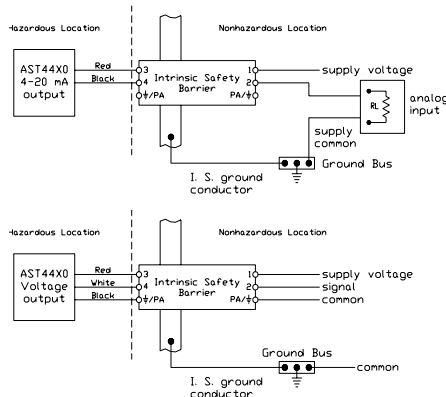

The transducers listed below are designed for installation in a Class I, Division 1, Groups C and D, Division 1 hazardous location when connected to Associated Apparatus as described in note 1.

Entity Parameters
V_{max} = 28Vdc
I_{max} = 175mA
C_i = 0.44uF
L_i = 0

I_{max} is the total current available from the Associated Apparatus under any condition.

- Notes:
- Associated Apparatus shall provide intrinsically safe connections which meet the following parameters:
V_{oc} or V_t V_{max} C_a C_i + C_{leads}
I_{sc} or I_t I_{max} L_a L_i + L_{leads}
 - Control Room apparatus shall not generate in excess of 250V (U_{max}).
 - Installation should be in accordance with Article 504 in the National Electrical Code, ANSI/NFPA 70.