

GENERAL

The second generation Badger Electronic Preset meter is designed for handheld dispensing and batch dispensing of various fluids. The meter consists of a measuring element, LCD display, and a batch processor functionality. The meter is a rugged design for the most demanding environments.

The Badger Model EPM-2 meter has two modes of operation. It can be used as a handheld dispensing valve with a readout that allows the user to see the amount of fluid being dispensed. It can also be used to select a batch quantity to be dispensed. In preset batch mode the meter will dispense the desired amount of fluid and then shut off. The meter has a hard coat anodized body, LCP gears, and Viton seals, making it ideal for dispensing of a variety of fluids. The meter is easily calibrated in the field for fluids of different viscosity.

In the handheld dispensing mode the user pulls up on the handle to open the valve and as a fluid flows through the meter the quantity is displayed. To stop the flow the user simply releases the handle to close the valve. When the meter is used in batch mode the user selects the batch quantity to be dispensed from the buttons on the meter. The handle is then pulled into the full open position. The handle will then latch in the full open position until the batch quantity is dispensed. When the batch quantity is reached the handle will de-latch and flow will stop. The reset button can then be pushed to reset the batch display and start a new batch. There is a stop button on the meter to close the valve at any time during a batch dispense.

The meter features a resettable totalizer for individual batch, a second resettable totalizer for multiple dispense operations, and a lifetime non-resettable totalizer.

OPERATION

The unit is programmed to dispense in quarts, liters, pints, and gallons. You can program any batch size in a matter of seconds. A five digit liquid crystal display, accurate to the second decimal point, shows the exact amount of fluid dispensed.

Badger's EPM meter uses four replaceable AA batteries and is calibrated at the factory. The meter can also be recalibrated easily in the field for a fluid of different viscosity.

Electronic accuracy will help you save time and money. The preset feature will allow users to perform other service tasks while fluid is dispensed.



Electronic Preset Meter 2

FEATURES

- Oval gear driven meter
- Durable
- Lightweight
- Large, easy-to-read LCD display
- Ease of operation
- Totalization in liters and gallons
- Dispensing measurement in liters, quarts, pints, gallons
- Max. totalizer number: 99,999 Gallons or Liters
- Max. dispense volume: 99,999 Units
- Max. preset volume: 999 Units
- Calibration factor for different fluids
- Changeable units of measure
- Six programmable presets
- Total and resettable total
- Minimum 20,000 cycles on battery life
- History (previous 5 batches)
- Low battery indicator
- Low battery safety lock out feature
- Ability to save settings if power interrupted
- Uses standard AA batteries
- Viewable flow rate - readings in liters or gallons per minute
- In-line swivel standard with all meters
- Automatic shut-off at preset amount
- Emergency electrical shut-off
- Precision control valve operation



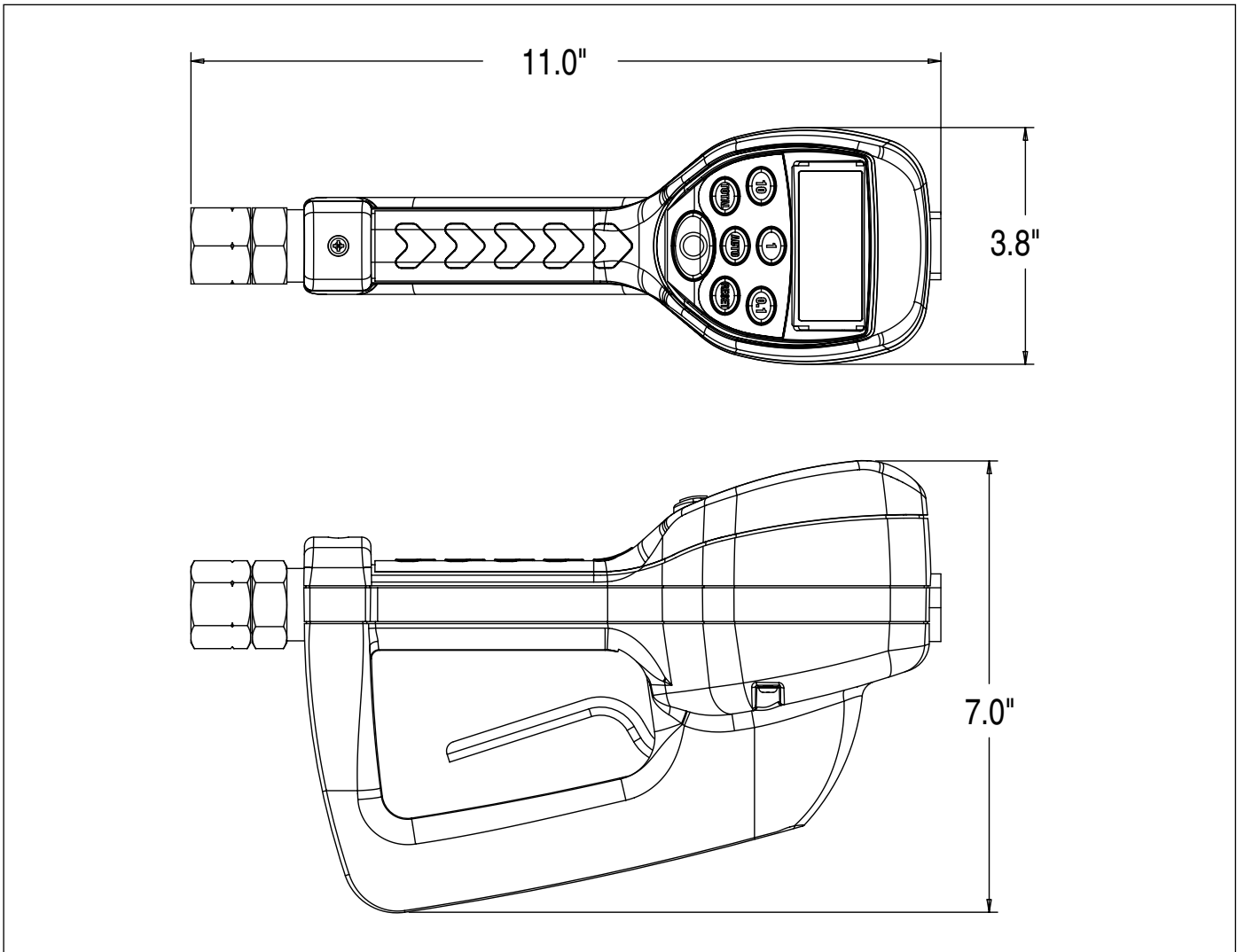

SPECIFICATIONS

	English	Metric
Maximum Flow *	10 gpm	38 lpm
Minimum Flow *	0.25 gpm	1 lpm
Operating Pressure (Maximum)	600 psi	42 bar
Operating Pressure (Minimum)	5 psi	.35 bar
Operating Temperature (Maximum)	120° F	50° C
Operating Temperature (Minimum)	20° F	- 5° C
Accuracy - General	+/- 0.5%	+/- 0.5%
5-Digit LCD Display	Quarts, Pints, Gallons	Liters
Inlet and Outlet Connections	½" NPT	½" BSPP

* Min.-Max. flow range will vary with fluid viscosity.

Badger® is a registered trademark of Badger Meter, Inc.



Please see our website at
www.badgermeter.com
 for specific contacts.

Due to continuous research, product improvements and enhancements, Badger Meter reserves the right to change product or system specifications without notice, except to the extent an outstanding contractual obligation exists.



BadgerMeter, Inc.

P.O. Box 245036, Milwaukee, WI 53224-9536
 Telephone: (414) 355-0400 / (800) 456-5023
 Fax: (414) 355-7499 / (866) 613-9305
www.badgermeter.com