

EZ-ZONE[®] RME (Expansion) Module

User's Guide

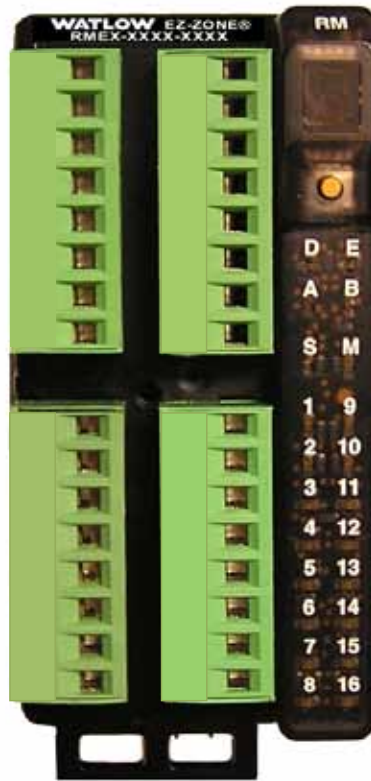

Expansion Module



1241 Bundy Boulevard., Winona, Minnesota USA 55987
Phone: +1 (507) 454-5300, Fax: +1 (507) 452-4507 <http://www.watlow.com>



ISO 9001



Registered Company
Winona, Minnesota USA

0600-0073-0000 Rev. C



June 2011

Made in the U.S.A.

Safety Information

We use note, caution and warning symbols throughout this book to draw your attention to important operational and safety information.









A “NOTE” marks a short message to alert you to an important detail.



A “CAUTION” safety alert appears with information that is important for protecting your equipment and performance. Be especially careful to read and follow all cautions that apply to your application.

A “WARNING” safety alert appears with information that is important for protecting you, others and equipment from damage. Pay very close attention to all warnings that apply to your application.

The safety alert symbol,  (an exclamation point in a triangle) precedes a general CAUTION or WARNING statement.

The electrical hazard symbol,  (a lightning bolt in a triangle) precedes an electric shock hazard CAUTION or WARNING safety statement. Further explanations follow:

Symbol	Explanation
	CAUTION – Warning or Hazard that needs further explanation than label on unit can provide. Consult User's Guide for further information.
	ESD Sensitive product, use proper grounding and handling techniques when installing or servicing product.
	Unit protected by double/reinforced insulation for shock hazard prevention.
	Do not throw in trash, use proper recycling techniques or consult manufacturer for proper disposal.
	Enclosure made of Poly carbonate material. Use proper recycling techniques or consult manufacturer for proper disposal.
	Unit can be powered with either alternating current (ac) voltage or direct current (dc) voltage.
	Unit is a Listed device per Underwriters Laboratories®. It has been evaluated to United States and Canadian requirements for Process Control Equipment. UL 61010 and CSA C22.2 No. 61010. File E185611 QUYY, QUYY7. See: www.ul.com
	Unit is a Listed device per Underwriters Laboratories®. It has been evaluated to United States and Canadian requirements for Hazardous Locations Class 1 Division II Groups A, B, C and D. ANSI/ISA 12.12.01-2007. File E184390 QUZW, QUZW7. See: www.ul.com

	Unit is compliant with European Union directives. See Declaration of Conformity for further details on Directives and Standards used for Compliance.
	Unit has been reviewed and approved by Factory Mutual as a Temperature Limit Device per FM Class 3545 standard. See: www.fmglobal.com
	Unit has been reviewed and approved by CSA International for use as Temperature Indicating-Regulating Equipment per CSA C22.2 No. 24. See: www.csa-international.org

Warranty

The EZ-ZONE® RME (Expansion) module is manufactured by ISO 9001-registered processes and is backed by a three-year warranty to the first purchaser for use, providing that the units have not been misapplied. Since Watlow has no control over their use, and sometimes misuse, we cannot guarantee against failure. Watlows' obligations hereunder, at Watlows' option, are limited to replacement, repair or refund of purchase price, and parts which upon examination prove to be defective within the warranty period specified. This warranty does not apply to damage resulting from transportation, alteration, misuse or abuse. The purchaser must use Watlow parts to maintain all listed ratings.

Technical Assistance

If you encounter a problem with your Watlow RME module, review your configuration information to verify that your selections are consistent with your application: inputs, outputs, alarms, limits, etc. If the problem persists, you can get technical assistance from your local Watlow representative (see back cover), by e-mailing your questions to wintechsupport@watlow.com or by dialing +1 (507) 494-5656 between 7 a.m. and 5 p.m., Central Standard Time (CST). Ask for an Applications Engineer. Please have the following information available when calling:

- Complete model number
- All configuration information
- User's Guide
- Factory Page

Return Material Authorization

1. Call Watlow Customer Service, (507) 454-5300, for a Return Material Authorization number before returning any item for repair. If you do not know why the product failed, contact an Application Engineer or Product Manager. All Return Material Authorization's require:
 - Ship-to address
 - Bill-to address
 - Contact name
 - Phone number
 - Method of return shipment
 - Your P.O. number
 - Detailed description of the problem
 - Any special instructions
 - Name and phone number of person returning the product.
2. Prior approval and a Return Material Authorization number from the Customer Service Department is required when

returning any product for credit, repair or evaluation. Make sure the RMA number is on the outside of the carton and on all paperwork returned. Ship on a Freight Prepaid basis.

3. After we receive your return, we will examine it and try to verify the reason for returning it.
4. In cases of manufacturing defect, we will enter a repair order, replacement order or issue credit for material returned. In cases of customer misuse, we will provide repair costs and request a purchase order to proceed with the repair work.
5. To return products that are not defective, goods must be in new condition, in the original boxes and they must be returned within 120 days of receipt. A 20 percent restocking charge is applied for all returned RM modules and accessories.
6. If the unit cannot be repaired, you will receive a letter of explanation and be given the option to have the unit returned to you at your expense or to have us scrap the unit.
7. Watlow reserves the right to charge for no trouble found (NTF) returns.

This EZ-ZONE RME User's Guide is copyrighted by Watlow Winona, Inc., © June 2011 with all rights reserved.

EZ-ZONE RM is covered by U.S. Patent No. 6,005,577 and Patents Pending



Table of Contents

- Chapter 1: Overview 3**
 - A Conceptual View of the RM System 5
- Chapter 2: Install and Wire 10**
 - Wiring 15
 - Conventions Used in the Menu Pages 28
- Chapter 3: Operations Pages 29**
 - Digital Input / Output Menu 30
 - Action Menu 30
 - Alarm Menu 30
 - Linearization Menu 31
 - Compare Menu 32
 - Timer Menu 32
 - Counter Menu 33
 - Logic Menu 33
 - Math Menu 34
 - Special Output Function Menu 35
- Chapter 4: Setup Pages 38**
 - Digital Input / Output Menu 40
 - Action Menu 41
 - Output Menu 43
 - Alarm Menu 46
 - Linearization Menu 48
 - Compare Menu 51
 - Timer Menu 52
 - Counter Menu 55
 - Logic Menu 57
 - Math Menu 66
 - Special Output Function Menu 70
 - Variable Menu 74
 - Global Menu 74
- Chapter 5: Factory Pages 75**
 - Custom Setup Menu 76
 - Security Setting Menu 76
 - Security Setting Menu 78

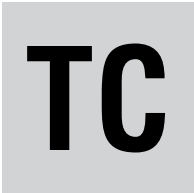

Table of Contents (cont.)

- Diagnostics Menu 78
- Chapter 6: Features 79**
 - Saving and Restoring User Settings 80
 - Inputs 80
 - Outputs 80
 - Alarms 81
 - Using Password Security 84
 - Software Configuration 86
 - Function Block Descriptions 89
- Chapter 7: Appendix 110**
 - RME Specifications 110
 - Index 113
 - How to Reach Us 116

1

Chapter 1: Overview

The EZ-ZONE® Rail Mount Expansion module (RME) takes the pain out of adding I/O points to your RM system architecture.

It just got a whole lot easier to solve the thermal requirements of your system. The RME module is provided in a space-saving, rail-mount package and is highly scalable where you only pay for what you need. For those applications that require the ability to configure/monitor the control over a network, other communications protocols are also available (e.g., EtherNet/IP, DeviceNet, Modbus TCP and Profibus DP) when used in conjunction with an RM Access (RMA) module or when using a Remote User Interface/ Gateway (RUI/GTW). Using your browser with an open connection to the internet, click on the link below and browse Watlow's web site to find other complimentary RM products and associated documentation.

<http://www.watlow.com/index.cfm>

Standard Features and Benefits

- Provides two mounting options (DIN rail, chassis mount)
- Reduces wiring time and termination complexity compared to connecting discrete products
- Reduces panel space and installation cost

Integrated power controller output

- Provides an optional dual Solid-State Relay (SSR) outputs, which can drive up to 10 amps into resistive loads. Terminals for the ring lug connection is optional
- Reduces component count and cost of ownership
- Saves panel space and simplifies wiring

Communication Capabilities

- Supports network connectivity to a PC or *PLC
 - Provides a wide range of *protocol choices including Modbus® RTU, EtherNet/IP™, Modbus® TCP, DeviceNet™ and Profibus DP
- * When used with the optional RMA or Remote User Interface/Gateway

Additional control integration options

- Provides a sequencer function
- Includes programmable timer functions
- Includes programmable counter functions
- Allows for simple math and logic programming options

Integrated Thermal Loop Diagnostics

- Users can easily tell that the entire thermal sys-

tem is functioning properly

- Provides complete system diagnostics that are far superior to simple discrete level diagnostics
- Helps prevent load loss or allow for maintenance to be scheduled when more convenient.
- Provides notification of system problems to help reduce maintenance and service costs

Off-the-Shelf Designed System Solution

- Improves system reliability with a factory integrated solution that minimizes inter-module connections and potential problems at screw termination points.
- Reduces installation cost
- Eliminates compatibility headaches often encountered with using many different components and brands

RME Handles High Ambient Temperatures

- Operates in an unprecedented temperature range of -18 to 65°C (0 to 149°F) for cabinets and panel enclosures with elevated temperature levels

Optional Access Module Available

- Serves as a configuration station
- Provides communication capabilities between the other modules and the PC or PLC
- Stores corresponding module parameter settings for easy auto-configuration of other additional modules or replacement modules
- Serves as a configuration station, which programs initial module setup or automatic programming of modules if swapping out after initial installation
- Provides a USB port for uploading and downloading configuration or data log files directly to a PC
- Saves time and increases reliability of parameter setting
- Logs process data

Memory for Saving and Restoring User-Defined Parameter Default Settings

- Allows customers to save and restore their own defined defaults for machine parameter settings
- Reduces service calls and downtime due to inadvertent end user parameter adjustments

RM Modules Allow for Greater Design Flexibility

- Saves money because you do not pay for any more than you need and don't settle for any less functionality than you need

Synergistic Module Control (SMC)

- Allows outputs selected for control (heat/cool), alarms or events to be located in any physical module, regardless of which module is connected to the input sensor

Split-Rail Control (SRC)

- Allows modules to be mounted together or mounted remotely from one another
- Shares control operation via Synergistic Module Control (SMC) capability
- Allows individual modules to be mounted closer to the physical input and output devices to which they are wired
- Improves system reliability and lowers wiring costs

Agency Certifications: UL® listed, CE, RoHS, W.E.E.E. SEMI F47-0200, Class 1 Div. 2 Rating on Selected Models

- Assures prompt product acceptance
- Reduces panel builder's documentation and agency costs

Removable Connectors

- Assures reliable wiring and reduces service calls
- Simplifies installation
- Provides a terminal option for accepting ring lug connection

Three-Year Warranty

- Demonstrates Watlow's reliability and product support

A Conceptual View of the RM System

The flexibility of the RM system software and hardware allows for a large range of configurations. Focusing on the RME module, acquiring a better understanding of its overall functionality and capabilities while at the same time planning out how this module can be used will deliver maximum effectiveness in your application.

The RM system at a high level can have a total of 17 modules installed, one of which can be an Access module and the others (16 maximum) can be any combination of available RM modules. Each installed RM module must have a unique Standard Bus address ranging from 1-9, A-F, H (10 -16). The Access module will be delivered with a default Standard Bus address of 17 (J). If not using the default zone address the user will need to define each zone address via the button on the face of each module.

The RME can be considered an accessory RM module in that by itself it has no PID control loops. However, used in conjunction with an RM Controller (RMC) or RM High Density (RMH) module the RME provides increased I/O capabilities. Outputs of the RME can be used to drive output loads of various kinds. For instance, an RME module could be placed in a remote location (up to 200 feet away) from a PID controller such as an RMC or RMH to drive a heater.

Some of the user selectable ordering options are listed below:

1. Class 2 or SELV (Safety Extra Low Voltage) equivalent Power Supplies:
 - 90-264 Vac to 24Vdc @ 31 watts
 - 90-264 Vac to 24Vdc @ 60 watts
 - 90-264 Vac to 24Vdc @ 91 watts
2. RM Expansion Module can provide:
 - 1 to 24 Digital Inputs/Outputs (I/O)
 - 4 to 12 Form A Mechanical Relays
 - 2 to 4 Form A 10A Solid-State Relays
 - 4 inputs for external Current Transformers (CT)

When using this module, either as a stand-alone module or used in conjunction with any other RM module it is useful to remember that each process needs to be thought out carefully and the controller's inputs, functions and outputs configured properly.

Note:

Zones can communicate with one another over the backplane (local and split rail). Once the system is configured and running changing zone addresses without careful deliberation may cause disruption in operation.

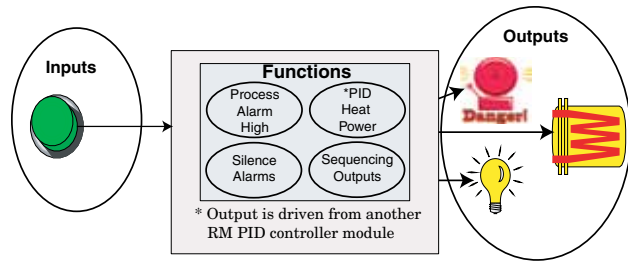

What is an Instance?

The RM system can have many I/O points, in some cases, as described above, I/O can be placed in remote locations. For example, an RME module can have 24 digital I/O where each would be numbered from 1 to 24 and each would be considered a unique instance. They are named Digital I/O 1, 2, 3, etc... These instance numbers are then used when you link inputs, functions and outputs within a module or when linked to other modules. For example, when configuring an RME output for heat the control loop instance (1, 2, 3 or 4) and zone (1 to 16) to drive the output must be defined.

Functions

Functions, in simple terms, use input signals (real-world or internal), to calculate a value and deliver an output. A function may be as simple as configuring the function of the digital output, e.g., alarm, heat, etc..., or defining a set point for an alarm state to turn on or off.

To set up a function, one of the first things that must be considered is the function source and instance. For example, if the control is equipped with Digital Inputs (source) and it was decided to use DI 9 (instance) it can then be associated with an Action to reset an individual alarm or all alarms. The steps below, walk through this configuration:

Setup Page (Digital I/O Menu)

1. Navigate to the Setup Page and then to the Digital I/O menu.
2. Select the desired instance and set the direction to input voltage or input dry contact.

Setup Page (Action Menu)

3. Navigate to the Setup Page and then the Action menu.
4. Set the Action Function to Alarm
5. Select which alarm instance will be reset (0 equals all)
6. Select the Source Function to Digital I/O
7. Select the Source Instance (step 2 above)
8. Select the Source Zone (0 equals the module being configured).
9. Select the Active Level to execute the desired function.

When the selected digital input is active the alarm or all alarms that are latched without a currently existing alarm condition will be reset. If a specific alarm instance (1 - 8) is selected (step 5 above), it will be

that instance alone that will be reset.

Note:

Alarms will reset automatically when the condition that caused the alarm goes back to a non-alarm state if the alarm latching prompt is set to non-latching (Setup Page, Alarm Menu).

Keep in mind that a function is a user-programmed internal process that does not execute any action outside of the controller. To have any affect outside of the controller, an output must be configured to respond to a function.

Some functions have a hardware input for which the source/s are preset and cannot be changed. As an example, CT 1 source function comes not surprisingly, from the CT attached to it. Most functions can accept more than one input and it would not be uncommon to see the output of one function (internal) serve as an input to another, as would be the case with a compare function. The source parameters for the first input to a function are called Source Function A, Source Instance A and Source Zone A and the second input, Source Function B, Source Instance B and Source Zone B and so on.

Inputs

The inputs provide the information that any given programmed function can act upon. This information may come from an operator pushing a button, or as part of a more complex function it may represent one of ten inputs used for the Linearization function.

Each digital input reads whether a device is active or inactive. An RME module can be equipped with up to 24 digital inputs, where the RM system can have many more. Each digital I/O point must be configured to function as an input or an output with the direction parameter in the digital I/O Menu (Setup Page).

Another concept that needs to be understood is the difference between an input tied to a real-world device such as a CT and one that is tied to an internal function.

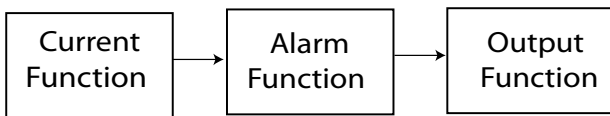

In the example above one can see the Current function on the left which is connected to a real-world input device (CT) where on the far right the internal output of the Alarm function is tied to the input of the Output function where a real-world output device is then driven such as a siren or a flashing light.

With a slight modification of the graphic above the example below now ties the real-world analog inputs from an RMC module directly to its PID control. The RME module is using the same analog input to drive an alarm function. For the sake of this example the following is true:

- Within the RME two unique high process alarms are configured for analog inputs 1 and 2 of the

RMC module

- The logic block (within the RME module) is configured as an OR function
- The RME output function is tied to the internal output of the logical OR function

When either process alarm is true (analog input value is greater than the alarm high set point, the real-world output connected to the RME will be driven on.

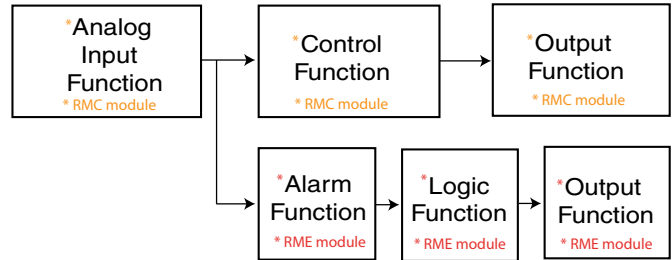

Outputs

Outputs can perform various functions or actions in response to information provided by a function, such as a digital output to turn a light on or off, unlocking a door; or turning on a buzzer.

Assign a function to an output in the Output Menu or Digital Output Menu of the Setup Page. Then select which instance of that function will drive the selected output. For example, you might assign an output to respond to an internal output of a compare function.

You can assign more than one output to respond to a single instance of a function, e.g., alarm 2 could be used to trigger a light connected to output 1 and a siren connected to digital output 5.

Actions

Based on a given input (Digital I/O, Logic function, etc..) the Action function can cause other functions to occur. To name a few, silencing alarms, turn control loops off and placing alarms in non-alarm state.

A Conceptual View of RM Hardware Configurations

Due to the scalability and flexibility in the system components a user has several options available in the way that the hardware can be connected. Listed below are a few examples.

RM System Connected to a Remote User Interface (RUI) and a PC

In this configuration the RUI and PC are connected to the RM system via Watlow's Standard Bus where both will be able to talk directly to any interconnected system module.

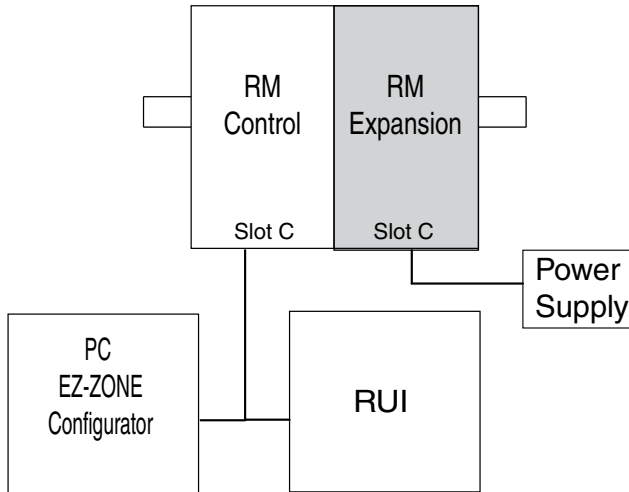

The PC running EZ-ZONE Configurator software and the RUI can be used to configure and then monitor both modules.

RM System Connected to a Programmable Logic Controller (PLC) on a DIN Rail

In this configuration the PLC can be connected to the RM system via the Access module using one or more available protocols:

1. EtherNet/IP and or Modbus TCP
2. DeviceNet
3. Modbus RTU
4. Profibus DP

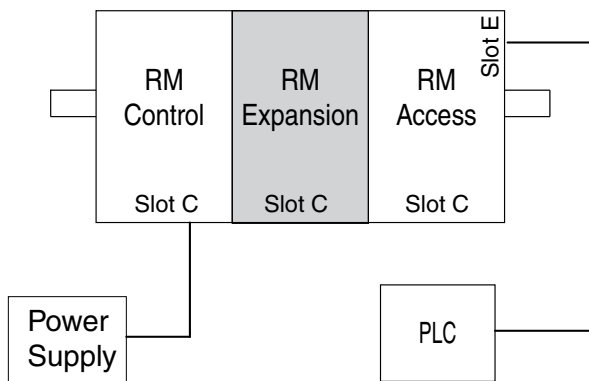

RM System Connected to an Operator Interface Terminal (OIT) through an RUI/Gateway

In this configuration the HMI can be running any of a number of protocols communicating to the RM system through Watlow's RUI/Gateway. Available protocols for the RUI/Gateway follow:

1. EtherNet/IP and or Modbus TCP
2. DeviceNet
3. Modbus RTU
4. Profibus DP

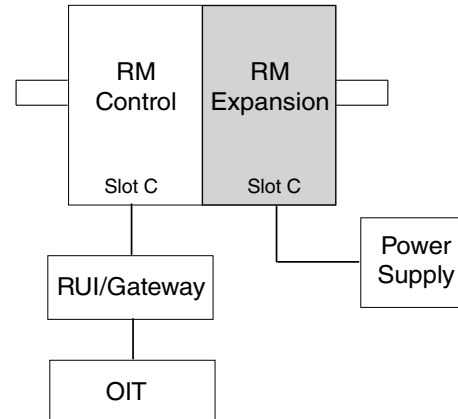

RM System Connected to a Split Rail with OIT

In this configuration both the Inter-module Bus (backplane communications) and Standard Bus are connected between rails to allow for remote capabilities. It is recommended that the split rail connection not exceed 200 feet. In this configuration the OIT can communicate with all modules (maximum 16 modules any combination with one Access module).

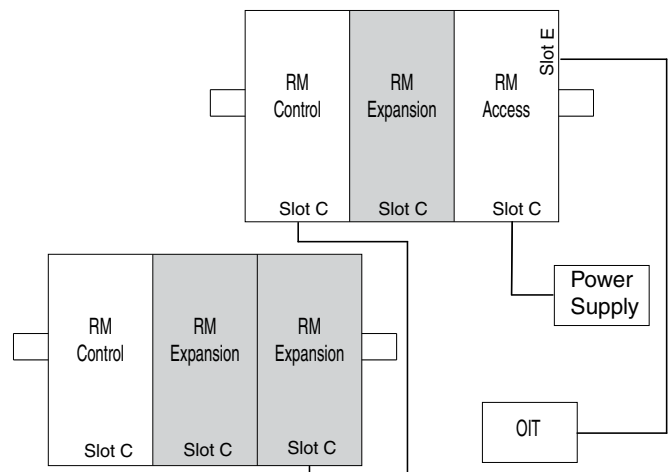

Module Orientation

The picture below represents one of six possible RM modules. All six will have four slots on the face (slot A, B, D, and E) and one on the bottom (slot C) not shown. All of these slots are not always used on all modules. On the face of the module there is a button (white circle) under the Zone address (5) that when pushed and held has the following functions:

1. For any module, push and hold for ~ 2 seconds. The address will intensify indicating that it can now be changed. Release and repeatedly press to change to the desired unique address. Valid addresses over Standard Bus range from 1 -16 (1 - 9, A is 10, B is 11, C is 12, D is 13, E is 14, F is 15, and h is 16). The Access module is shipped at address J or 17

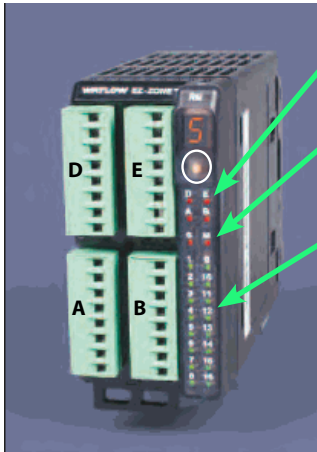

Module Status (Slot A, B, D, or E)

Protocol (Standard Bus - red)

Module outputs 1 through 16, all may or may not be used depending on module type

EZ-ZONE RM-Expansion Module - System Diagram with up to 24 Inputs/Outputs

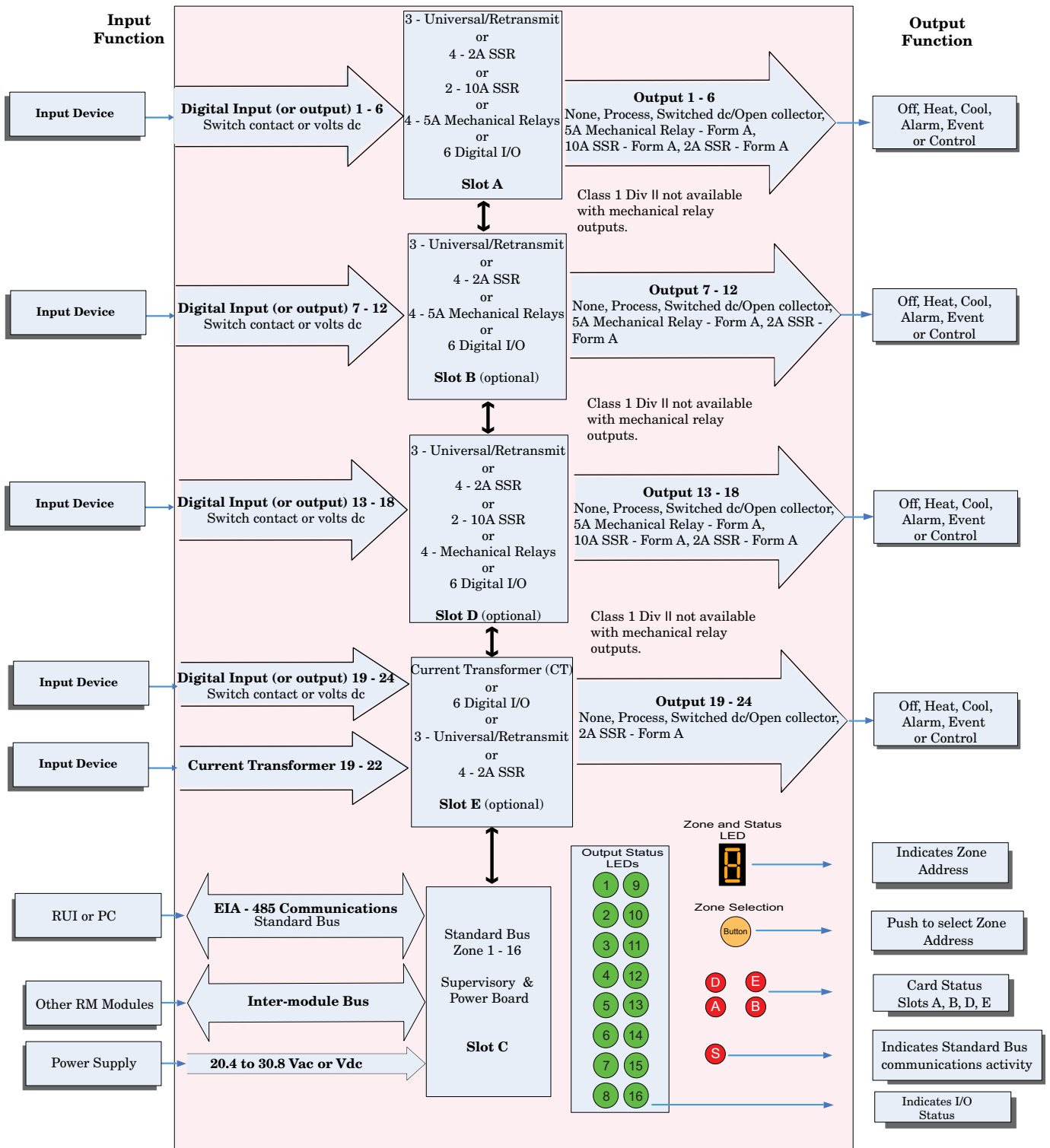

2

Chapter 2: Install and Wire

Dimensions

As can be seen below the dimensions of the RME modules will change slightly based on the type of connector used.

Module Removal Clearance

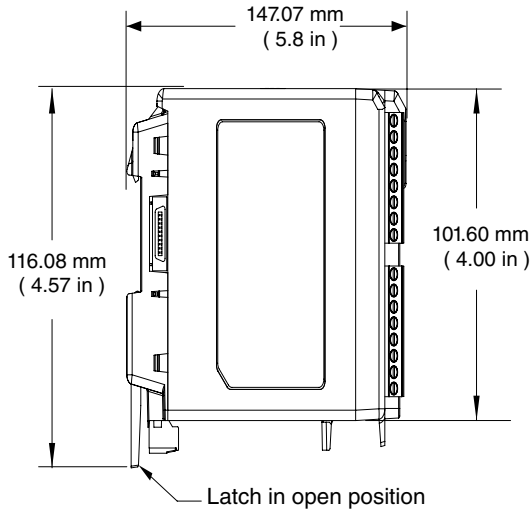

Standard Connectors

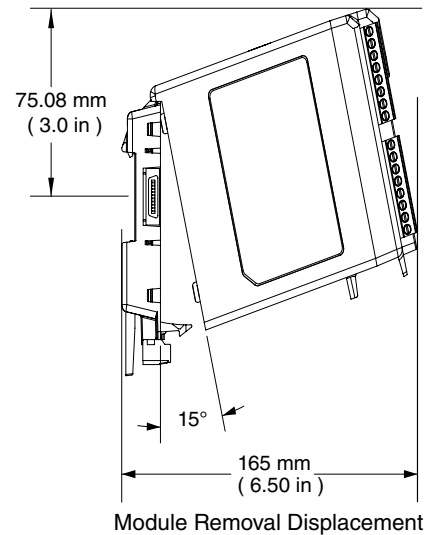
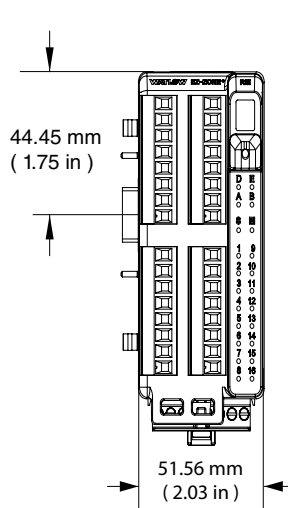

Module Removal Clearance

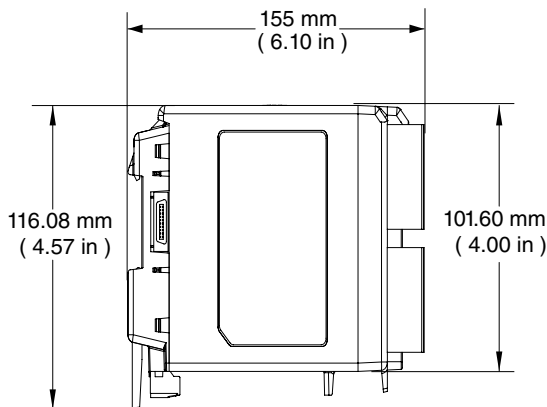

Straight Connectors

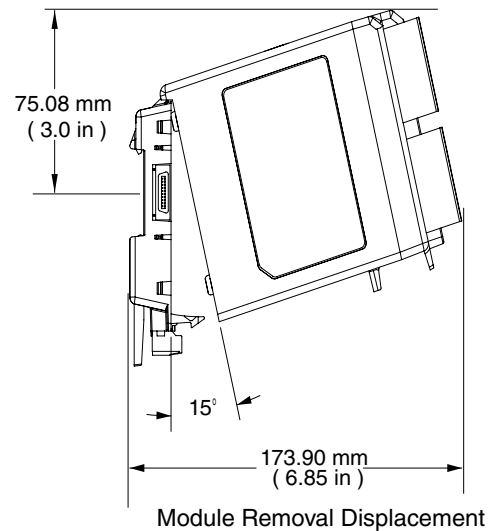
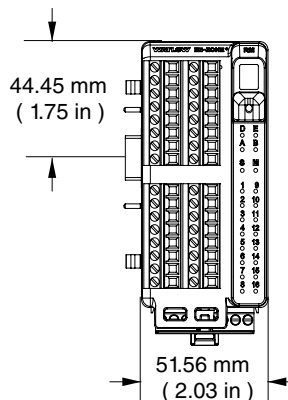

Dimensions

Module Removal Clearance

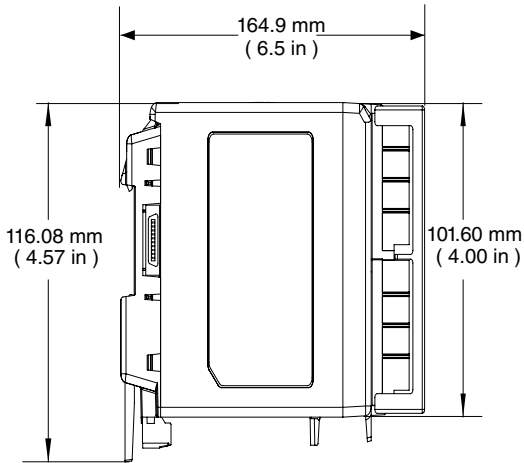

Ring Terminal Connectors

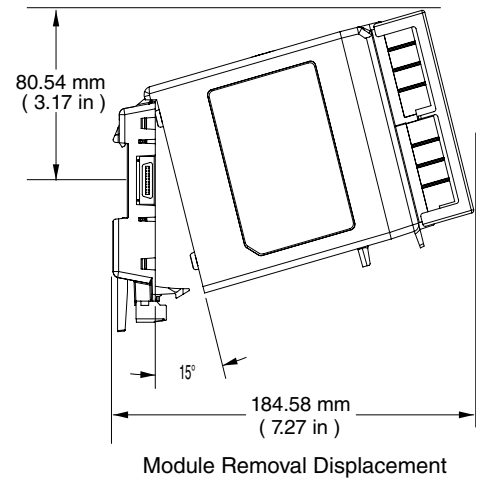
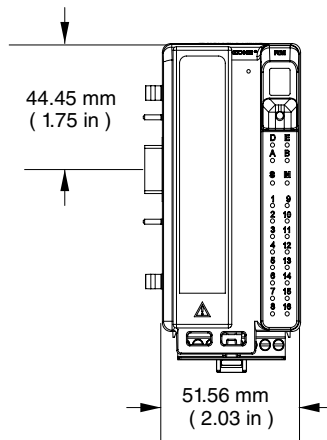

Chassis Mount Front View (Module Removed) - Screw Connection Pattern

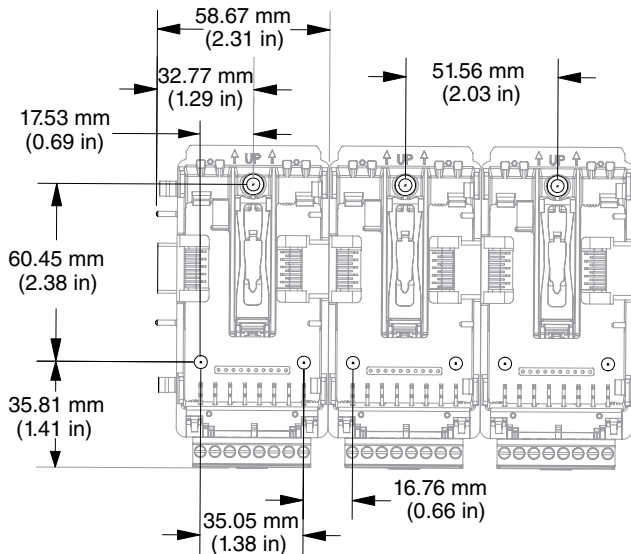

The view above is representative of the modular backplane without the module.

Recommended chassis mount hardware:

1. #8 screw, 3/4" long
2. Torque to 10 -15 in-lb
3. No washers of any kind

Power Supplies

DSP30

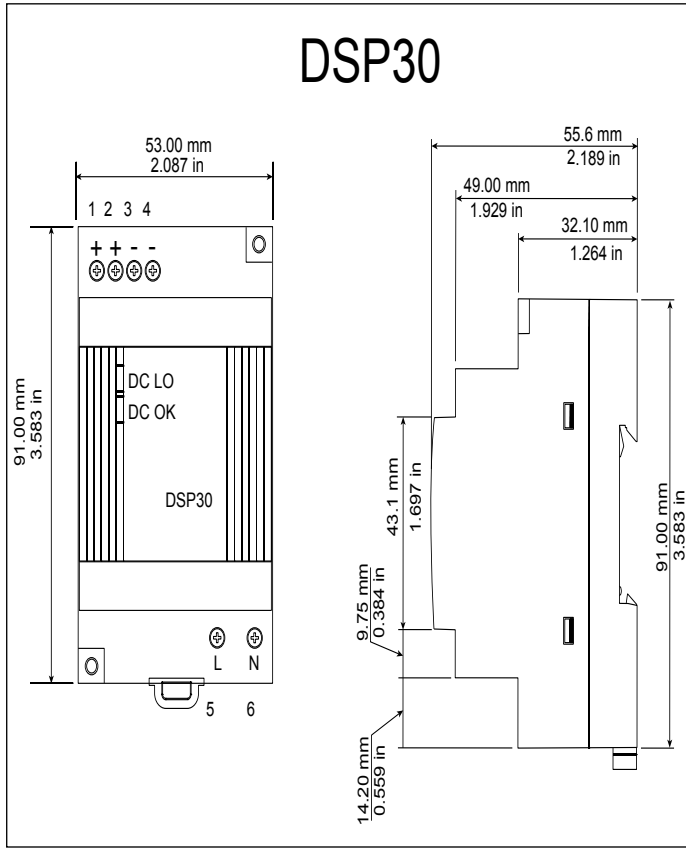

DSP60

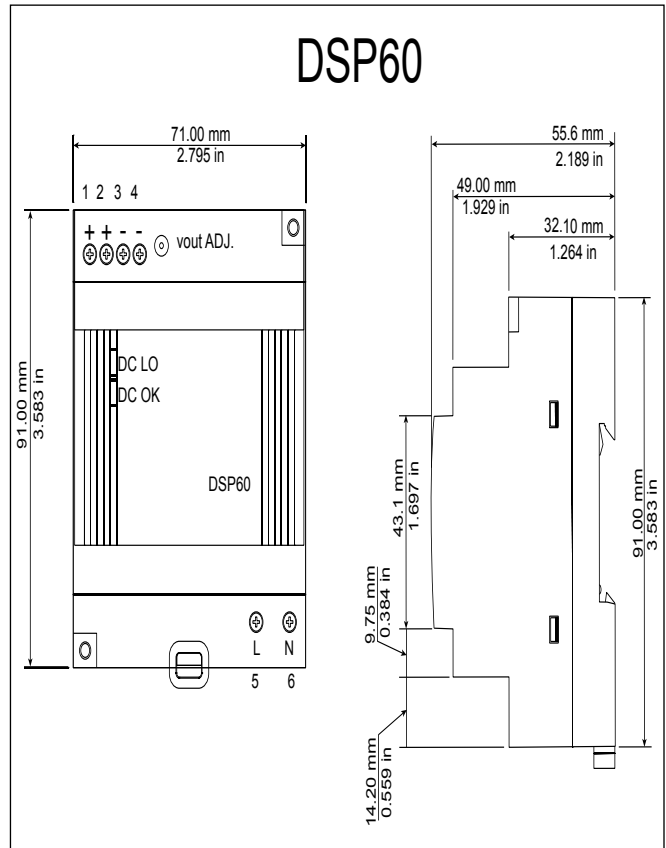

DSP100

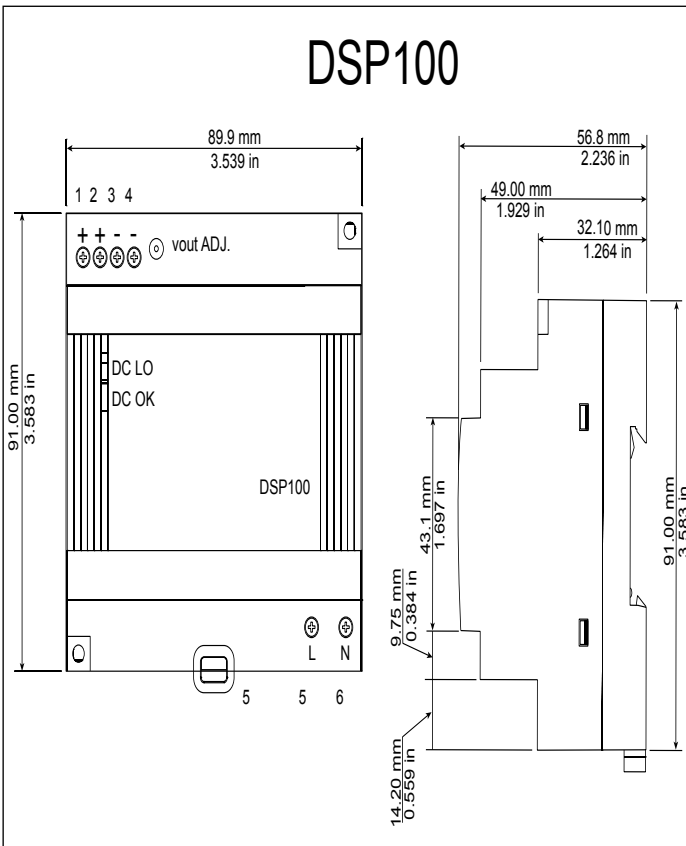

Power Supply Specifications

		DSP 30	DSP60	DSP100
AC Input Voltage Range	VAC	90 - 264VAC, Class II double insulated (No ground connection required)		
Input Frequency	Hz	47 - 63Hz		
DC Input Voltage range	VDC	120 - 370VDC		
Inrush Current (115 / 230VAC)	A	25 / 50A	30 / 60A	30 / 60A
Output Voltage Accuracy	%	±1% of Nominal		
Over voltage Protection	V	120 - 145%		
LED Indicators	----	Green LED = On, Red LED = DC Output Low		
Operating Temperature	----	-25 to +71°C (Derate linearly 2.5%/°C from 55 to 71°C)		
Storage Temperature	----	-25 to +85°C		
Operating Humidity	----	20 - 95% RH (non condensing)		
Vibration (Operating)	----	IEC 60068-2-6 (Mounting by rail: Random wave, 10-500 Hz, 2G, ea. along X, Y, Z axes 10 min/cycle, 60 min)		
Safety Agency Certifications	----	UL1310 Class 2(1), UL508 Listed, UL60950-1, EN60950-1, CE		

For a comprehensive listing of these specifications point your browser to : <http://us.tdk-lambda.com/lp/products/dsp-series.htm>

RME Installation and Removal on a DIN Rail

Modular Backplane Connector

The picture on the right shows the Modular Backplane Connector, both front and rear view. The rear view is bringing in to focus a metal clip. If the DIN rail is grounded the Modular Backplane Connector and the module connected to it will be also (recommended).

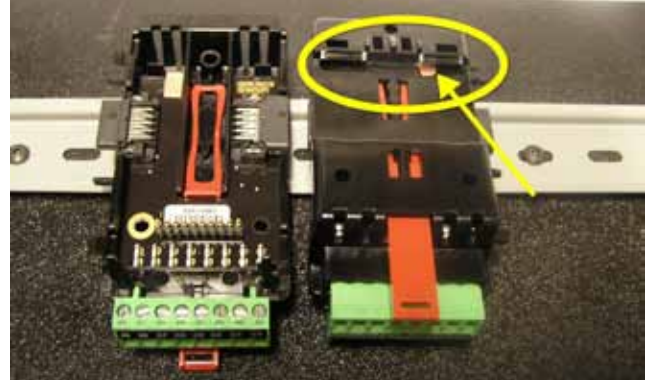

Installing the Modular Backplane Connector

Step 1

Hook backplane assembly to upper edge of DIN rail, (see rear view above, backplane hook detail that mates with upper rail edge is circled)

Step 2

Next, rotate back plane assembly downward to engage the lower edge of the rail. (Note: Din Rail clipping distance ranges from 1.366 -1.389 inches. The back plane assembly will not latch onto the rail successfully if the rail is out of dimension).

Step 3

For final positioning and locking, the red tab is to be pushed upward to further engage the bottom edge of the rail with an over center snap action latch. (The red locking tab protrudes from the bottom side of the back plane assembly).



Installing Multiple Modular Backplane Connectors

Multiple modules are easily aligned and latched together. Each module includes matched mating geometry that facilitates accurate and consistent interconnections. The recommended method of multi-module attachment is to first attach individual modules to the rail separately and second to laterally slide the modules together until they touch. (Refer to steps 1&2 above). When the multi-module system is attached and laterally positioned to the desired placement the locking tab should be engaged to secure the control system to the rail, (Refer to step 3 above).

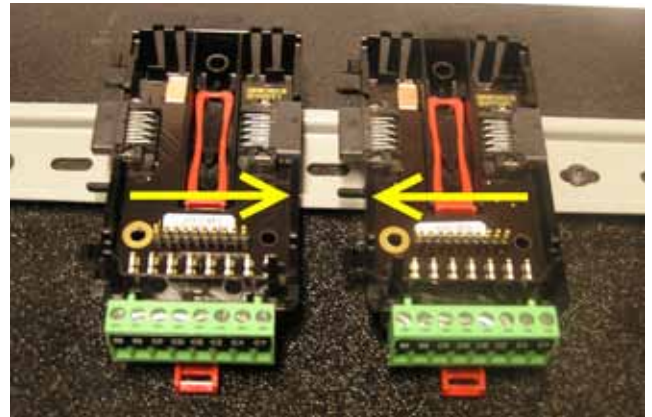

Module Installation

In the picture to the right notice that the arrow is pointing at the top lip of the module (on side). When installing the module simply slide this lip over the top of the Modular Backplane Connector and then push down on the rear of the module where it will seat on the two posts just above the green connector.



Module Removal

To remove a module from the Modular Backplane Connector find the red tab protruding from the bottom of the module and pull back on it as shown to the right. While pulling back on the red tab the two mounting posts will release the module where the module can then be lifted up and out of the Modular Backplane Connector.

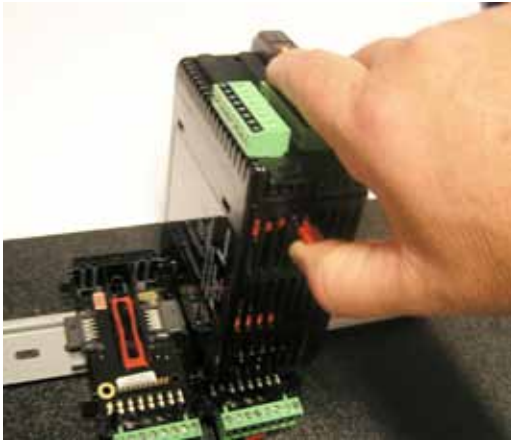

Removal of the Modular Backplane Connector

A module can be removed from the Modular Backplane Connector by inserting a screw driver into the red locking tab just behind the green connector and applying downward pressure on the tab by lifting the screwdriver upwards. When released, the tab will move downward and the connector can then be lifted up off of the DIN rail.

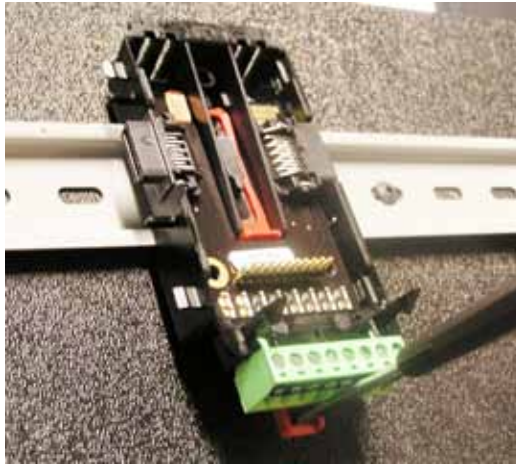

Wiring

Expansion Module (RME x - x x x x - x x x x)					
Slot A	Slot B	Slot D	Slot E	Terminal Function	Configuration
Inputs				Digital Inputs	
1 - 6	7 - 12	13 - 18	19 - 24		
B1 D1 D2 D3 D4 D5 D6 Z1	B7 D7 D8 D9 D10 D11 D12 Z7	B13 D13 D14 D15 D16 D17 D18 Z13	B19 D19 D20 D21 D22 D23 D24 Z19	Common dc+ input dc+ input dc+ input dc+ input dc+ input dc+ input Internal Supply	6 Digital Inputs Part # Digits 5, 6, 7, 8 Slot A: RME _ - [C] _ _ _ _ - _ _ _ _ Slot B: RME _ - _ [C] _ _ - _ _ _ _ Slot D: RME _ - _ _ [C] _ - _ _ _ _ Slot E: RME _ - _ _ _ [C] - _ _ _ _
				Current Transformer Inputs	
---	---	---	19 - 22		
---	---	---	T19 S19 T20 S20 T21 S21 T22 S22	mA ac mA ac mA ac mA ac mA ac mA ac mA ac mA ac	Quad Current Transformers Part # Digit 8 Slot E: RME _ - _ _ _ [T] - _ _ _ _
Outputs				Digital Outputs	
1 - 6	7 - 12	13 - 18	19 - 24		
B1 D1 D2 D3 D4 D5 D6 Z1	B7 D7 D8 D9 D10 D11 D12 Z7	B13 D13 D14 D15 D16 D17 D18 Z13	B19 D19 D20 D21 D22 D23 D24 Z19	common open collector/ switched dc open collector/ switched dc open collector/ switched dc open collector/ switched dc open collector/ switched dc open collector/ switched dc internal supply	Digital Inputs Part # Digits 5, 6, 7, 8 Slot A: RME _ - [C] _ _ _ - _ _ _ _ Slot B: RME _ - _ [C] _ _ - _ _ _ _ Slot D: RME _ - _ _ [C] _ - _ _ _ _ Slot E: RME _ - _ _ _ [C] - _ _ _ _
				4, 2A Solid-State Relay (SSR) Outputs	
1 - 4	7 - 10	13 - 16	19 - 22		
L1 K1 L2 ---	L7 K7 L8 ---	L13 K13 L14 ---	L19 K19 L20 ---	normally open common normally open <i>not used</i>	2A SSR Outputs Part # Digits 5, 6, 7, 8 Slot A: RME _ - [L] _ _ _ - _ _ _ _ Slot B: RME _ - _ [L] _ _ - _ _ _ _ Slot D: RME _ - _ _ [L] _ - _ _ _ _ Slot E: RME _ - _ _ _ [L] - _ _ _ _
L3 K3 L4	L9 K9 L10	L15 K15 L16	L21 K21 L22	normally open common normally open	
				Tri-State Process/Retransmit Outputs	
1 - 3	7 - 9	13 - 15	19 - 21		
F1 H1 ---	F7 H7 ---	F13 H13 ---	F19 H19 ---	voltage or current - voltage + or current + <i>not used</i>	Tri-Process Outputs Part # Digits 5, 6, 7, 8 Slot A: RME _ - [F] _ _ _ - _ _ _ _ Slot B: RME _ - _ [F] _ _ - _ _ _ _ Slot D: RME _ - _ _ [F] _ - _ _ _ _ Slot E: RME _ - _ _ _ [F] - _ _ _ _
F2 H2 ---	F8 H8 ---	F14 H14 ---	F20 H20 ---	voltage or current - voltage + or current + <i>not used</i>	
F3 H3	F9 H9	F15 H15	F21 H21	voltage or current - voltage + or current +	

Expansion Module (RME x - x x x x - x x x x)					
Slot A	Slot B	Slot D	Slot E	Terminal Function	Configuration
Outputs (cont.)				2, 10A Form A SSR Outputs	
1 - 2	---	13 - 14	---		
L1	---	L13	---	normally open	10A SSR Outputs Part # Digits 5, 7 Slot A: RME _ - [K] _ _ _ - _ _ _ _ Slot B: Not available Slot D: RME _ - _ _ [K] _ - _ _ _ _ Slot E: Not available
L1	---	L13	---	normally open	
K1	---	K13	---	common	
K1	---	K13	---	common	
L2	---	L14	---	normally open	
L2	---	L14	---	normally open	
K2	---	K14	---	common	
K2	---	K14	---	common	
				4, 5A Form A Mechanical Relay Outputs	
1 - 4	7 - 10	13 - 16	---		
L1	L7	L13	---	normally open	5A SSR Outputs Part # Digits 5, 6, 7 Slot A: RME _ - [J] _ _ _ - _ _ _ _ Slot B: RME _ - _ [J] _ - _ _ _ _ Slot D: RME _ - _ _ [J] _ - _ _ _ _ Slot E: Not available
K1	K7	K13	---	common	
L2	L8	L14	---	normally open	
K2	K8	K14	---	common	
L3	L9	L15	---	normally open	
K3	K9	K15	---	common	
L4	L10	L16	---	normally open	
K4	K10	K16	---	common	

Power and Communications		
Slot C	Terminal Function	Configuration
98	Power input: ac or dc+	All
99	Power input: ac or dc-	
CF	Standard Bus EIA-485 common	Standard Bus
CD	Standard Bus EIA-485 T-/R-	
CE	Standard Bus EIA-485 T+/R+	
CZ	Inter-module Bus	Inter-module Bus
CX	Inter-module Bus	
CY	Inter-module Bus	

All Modules - Front View -
Standard Connector

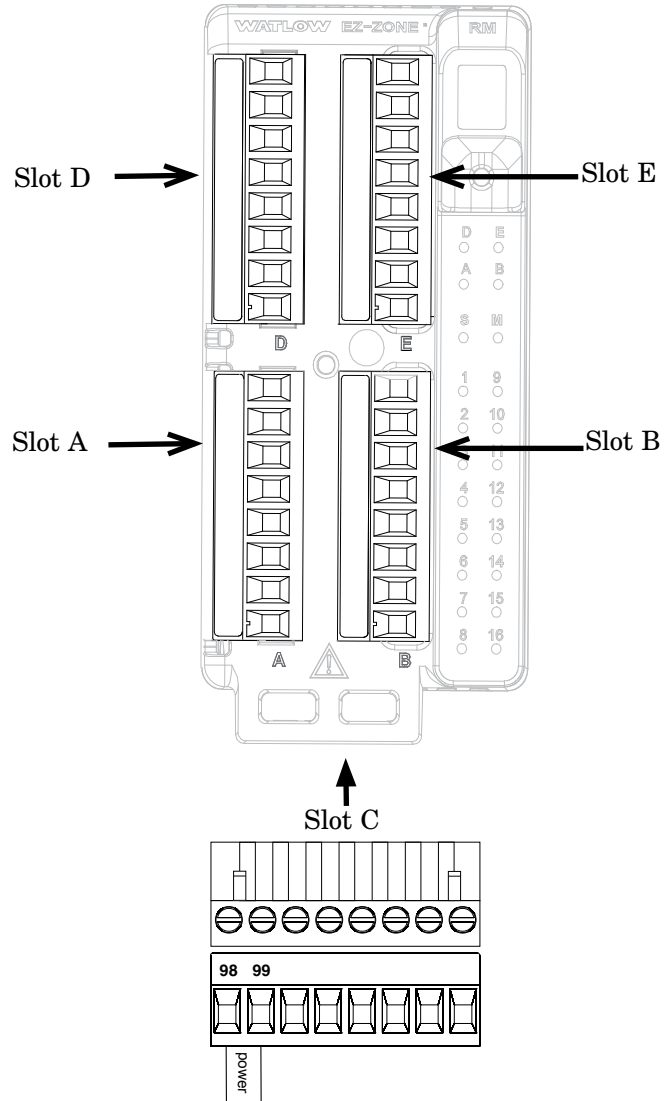

RME System Isolation Blocks

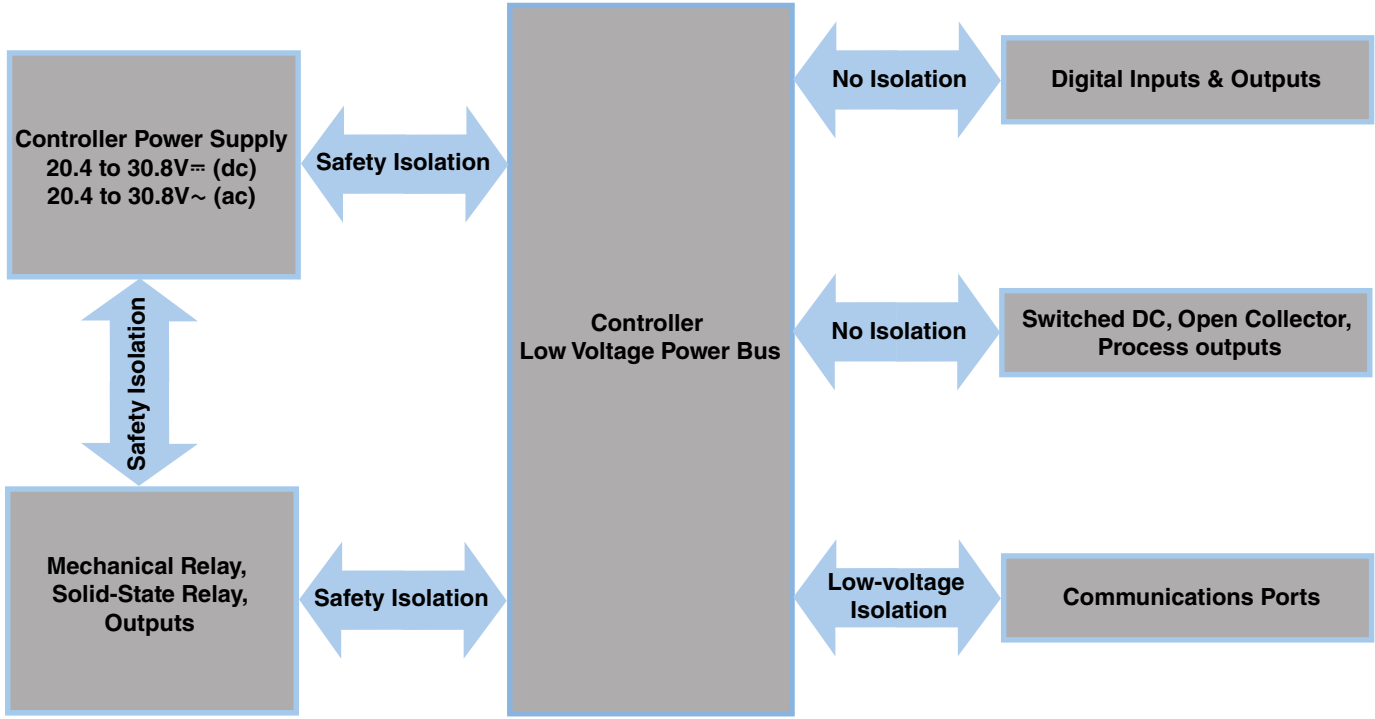

Low-voltage Isolation: 42V peak
Safety Isolation: 1,528V_{AC} (ac)

Warning:



Use National Electric (NEC) or other country-specific standard wiring and safety practices when wiring and connecting this controller to a power source and to electrical sensors or peripheral devices. Failure to do so may result in damage to equipment and property, and/or injury or loss of life.

Note:

Maximum wire size termination and torque rating:

- 0.0507 to 3.30 mm² (30 to 12 AWG) single-wire termination or two 1.31 mm² (16 AWG)
- 0.8 Nm (7.0 in-lb.) torque

Note:

Adjacent terminals may be labeled differently, depending on the model number.

Note:

To prevent damage to the controller, do not connect wires to unused terminals.

Note:

Maintain electrical isolation between digital input-outputs, switched dc/open collector outputs and process outputs to prevent ground loops.

Note:

If the last two digits of the part number are "12", this equipment is suitable for use in CLASS I, DIVISION 2, Groups A, B, C and D or Non-Hazardous locations only. Temperature Code T4

Warning:



Explosion Hazard – Substitution of component may impair suitability for CLASS I, DIVISION 2.

Warning:



Explosion Hazard - Do not disconnect while the circuit is live or unless the area is known to be free of ignitable concentrations of flammable substances.

Warning:



Explosion Hazard - Dry contact closure Digital Inputs shall not be used in Class I Division 2 Hazardous Locations unless switch used is approved for this application.

Expansion Module Wiring (RMExxxx-xxxx)

Low Power

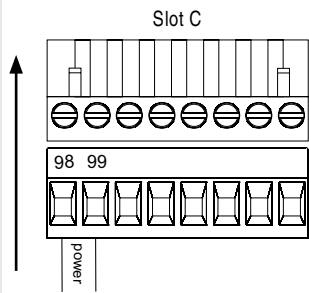

RME - All Model Numbers

- 20.4 to 30.8 V ~ (ac) / = (dc) 14VA
- 47 to 63 Hz
- Expansion module power consumption, 7 Watts maximum
- 31 Watts maximum power available for P/S part #:0847-0299-0000
- 60 Watts maximum power available for P/S part #:0847-0300-0000
- 91 Watts maximum power available for P/S part #:0847-0301-0000
- Class 2 or SELV power source required to meet UL compliance standards

Communications

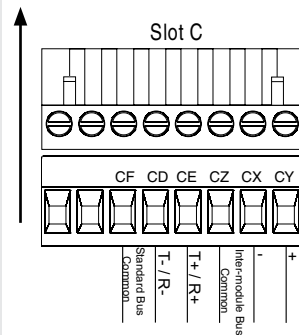

- CF, CD, CE - Standard Bus EIA485 Communications
- CZ, CX, CY - Inter-module Bus EIA485 Communications
- Do not route network wires with power wires. Connect network wires in daisy-chain fashion when connecting multiple devices in a network

Quad Current Transformer Inputs 19, 20, 21 and 22

RME Part # Digit 8 is T

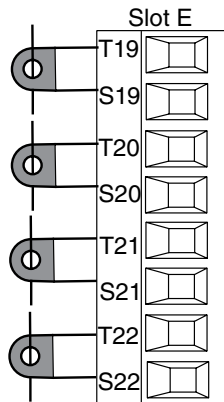

- Input range is 0 to 50 mA (ac).
- Current transformer part number: 16-0246
- 100 Ω input impedance
- Response time: 1 second maximum
- Accuracy +/-1 mA typical

Warning:



Use National Electric (NEC) or other country-specific standard wiring and safety practices when wiring and connecting this controller to a power source and to electrical sensors or peripheral devices. Failure to do so may result in damage to equipment and property, and/or injury or loss of life.

Note:

- Maximum wire size termination and torque rating:
 - 0.0507 to 3.30 mm² (30 to 12 AWG) single-wire termination or two 1.31 mm² (16 AWG)
 - 0.8 Nm (7.0 in.-lb.) torque

Note:

Adjacent terminals may be labeled differently, depending on the model number.

Note:

To prevent damage to the controller, do not connect wires to unused terminals.

Note:

Maintain electrical isolation between digital input-outputs, switched dc/open collector outputs and process outputs to prevent ground loops.

Note:

If the last two digits of the part number are "12", this Equipment is suitable for use in CLASS I, DIVISION 2, Groups A, B, C and D or Non-Hazardous locations only. Temperature Code T4

Warning:



Explosion Hazard – Substitution of component may impair suitability for CLASS I, DIVISION 2.

Warning:



Explosion Hazard - Do not disconnect while the circuit is live or unless the area is known to be free of ignitable concentrations of flammable substances.

Quencharc Note:

Switching pilot duty inductive loads (relay coils, solenoids, etc.) with the mechanical relay, Solid-State relay or open collector output options requires use of an R.C. suppressor.

Digital Inputs 1 to 24

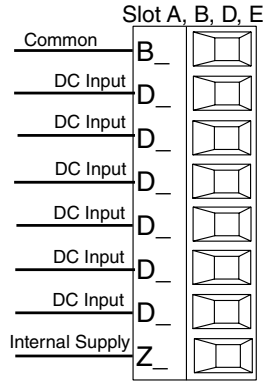

RME Part # Digit 5, 6, 7, 8 is C

Digital Input Event Conditions

- Dry Contact
 - Input inactive when > 100KΩ
 - Input active when < 50Ω
- Voltage
 - Input inactive when < 2V
 - Input active when > 3V
- Six user configurable Digital Inputs per slot

Voltage Input

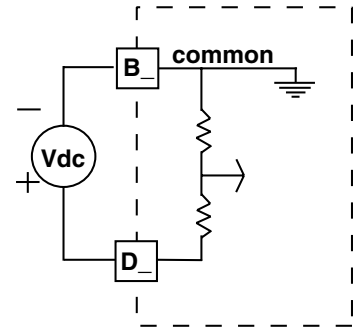

Dry Contact

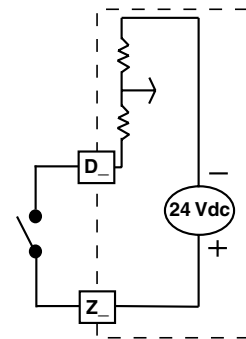

Digital Outputs 1 to 24

RME Part # Digit 5, 6, 7, 8 is C

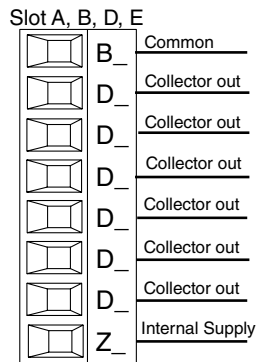

- Maximum switched voltage is 32V_{dc}
- Internal supply provides a constant power output of 750mW
- Maximum output sink current per output is 1.5A (external class 2 or *SELV supply required)
- Total sink current for all outputs not to exceed 8A
- Do not connect outputs in parallel
- *Safety Extra Low Voltage

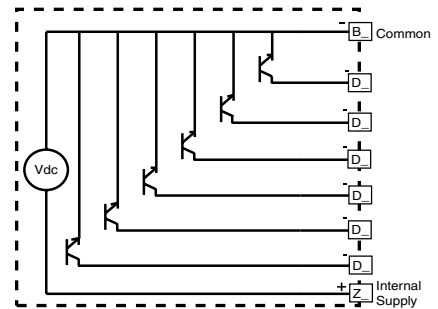

- Six user configurable Digital Outputs per slot

Warning:



Use National Electric (NEC) or other country-specific standard wiring and safety practices when wiring and connecting this controller to a power source and to electrical sensors or peripheral devices. Failure to do so may result in damage to equipment and property, and/or injury or loss of life.

Note:

Maximum wire size termination and torque rating:

- 0.0507 to 3.30 mm² (30 to 12 AWG) single-wire termination or two 1.31 mm² (16 AWG)
- 0.8 Nm (7.0 in.-lb.) torque

Note:

Adjacent terminals may be labeled differently, depending on the model number.

Note:

To prevent damage to the controller, do not connect wires to unused terminals.

Note:

Maintain electrical isolation between digital input-outputs, switched dc/open collector outputs and process outputs to prevent ground loops.

Note:

If the last two digits of the part number are "12", this equipment is suitable for use in CLASS I, DIVISION 2, Groups A, B, C and D or Non-Hazardous locations only. Temperature Code T4

Warning:



Explosion Hazard – Substitution of component may impair suitability for CLASS I, DIVISION 2.

Warning:



Explosion Hazard - Do not disconnect while the circuit is live or unless the area is known to be free of ignitable concentrations of flammable substances.

Quencharc Note:

Switching pilot duty inductive loads (relay coils, solenoids, etc.) with the mechanical relay, Solid-State relay or open collector output options requires use of an R.C. suppressor.

Digital Output (1 to 24) Wiring Example - Switched DC to DIN-A-MITE®

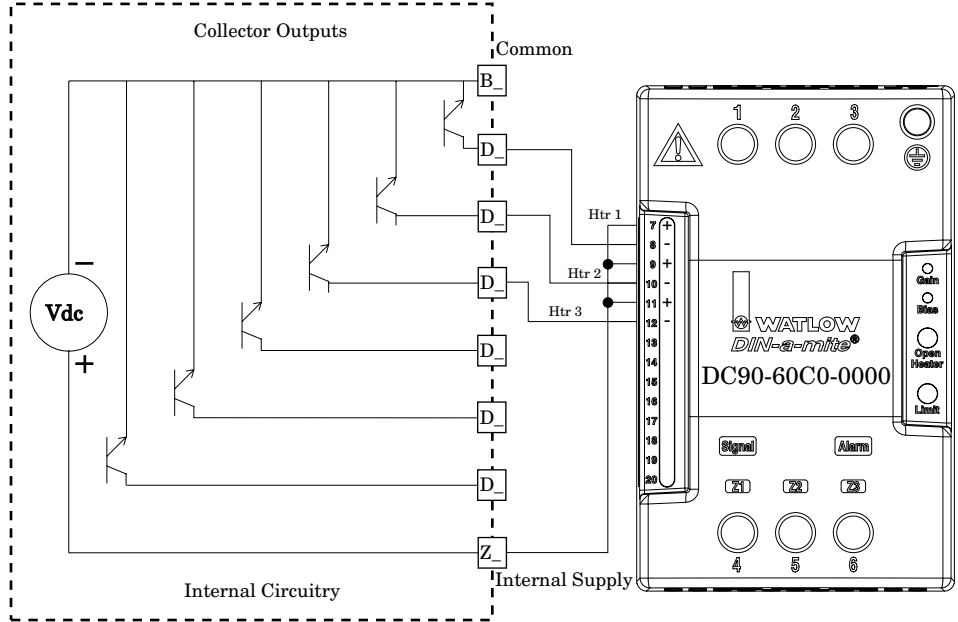

Digital Output (1 to 24) Wiring Example - Open Collector

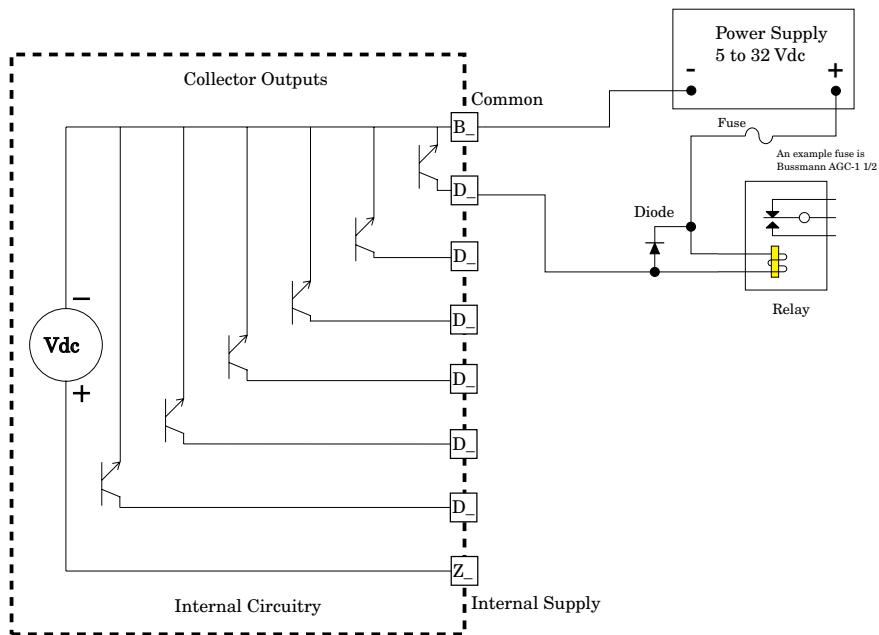

Quad Mechanical Relays, Form A Outputs 1-4, 7-10, 13-16

RME Part # Digit 5, 6, or 7 is J

Slot A, B, D

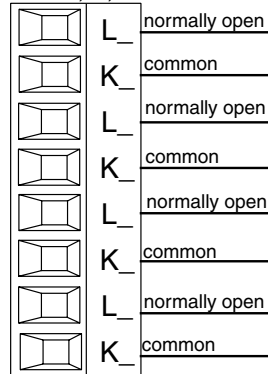

- 5 A at 240V (ac) or 30V (dc) maximum resistive load
- 20 mA at 24V minimum load
- 125VA pilot duty at 120/240V (ac), 25 VA at 24V (ac)
- 100,000 cycles at rated load
- output does not supply power
- For use with ac or dc
- Not available in slot E
- See Quencharc note.

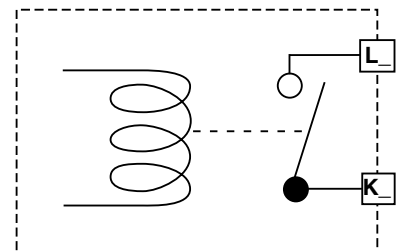

Warning: 

Use National Electric (NEC) or other country-specific standard wiring and safety practices when wiring and connecting this controller to a power source and to electrical sensors or peripheral devices. Failure to do so may result in damage to equipment and property, and/or injury or loss of life.

Note:

Maximum wire size termination and torque rating:

- 0.0507 to 3.30 mm² (30 to 12 AWG) single-wire termination or two 1.31 mm² (16 AWG)
- 0.8 Nm (7.0 in.-lb.) torque

Note:

Adjacent terminals may be labeled differently, depending on the model number.

Note:

To prevent damage to the controller, do not connect wires to unused terminals.

Note:

Maintain electrical isolation between digital input-outputs, switched dc/open collector outputs and process outputs to prevent ground loops.

Note:

If the last two digits of the part number are "12", this Equipment is suitable for use in CLASS I, DIVISION 2, Groups A, B, C and D or Non-Hazardous locations only. Temperature Code T4

Warning: 

Explosion Hazard – Substitution of component may impair suitability for CLASS I, DIVISION 2.

Warning: 

Explosion Hazard - Do not disconnect while the circuit is live or unless the area is known to be free of ignitable concentrations of flammable substances.

Quencharc Wiring Example



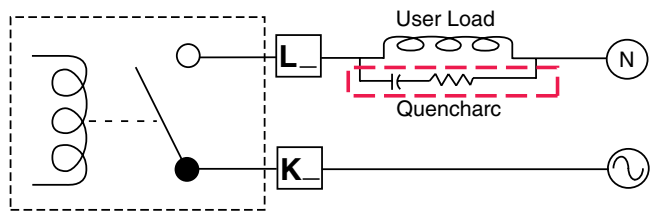





In this example the Quencharc circuit (Watlow part# 0804-0147-0000) is used to protect the RME internal circuitry from the counter electromagnetic force from the inductive user load when de-energized. It is recommended that this or an equivalent Quencharc be used when connecting inductive loads to the RME outputs.









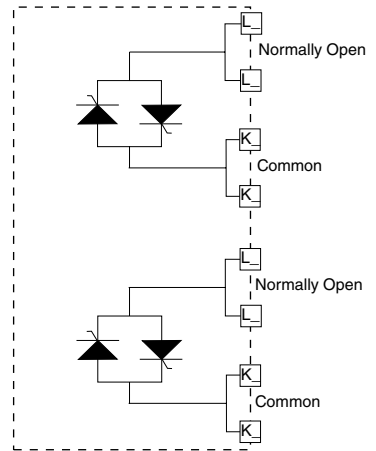

Dual 10A SSR Outputs 1-4

RME Part # Digit 5 or 7 is K

- Maximum resistive load 10 A per output @ 240V (ac)
- Maximum 20 A per slot @ 50 °C
- Maximum 12 A per slot @ 65 °C

Slot A	
	L1 normally open
	L1 normally open
	K1 common
	K1 common
	L2 normally open
	L2 normally open
	K2 common
	K2 common



Slot D	
	L3 normally open
	L3 normally open
	K3 common
	K3 common
	L4 normally open
	L4 normally open
	K4 common
	K4 common

Total Output Amps Per Slot

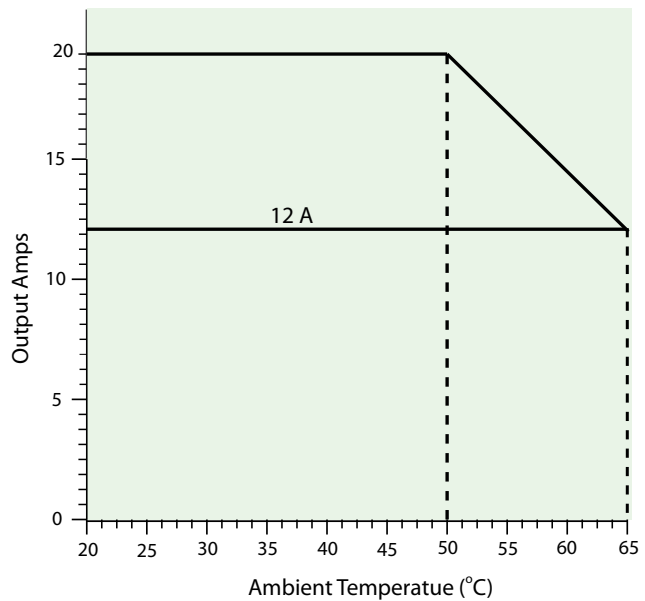

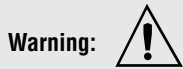

Warning:

Use National Electric (NEC) or other country-specific standard wiring and safety practices when wiring and connecting this controller to a power source and to electrical sensors or peripheral devices. Failure to do so may result in damage to equipment and property, and/or injury or loss of life.

Note:

Maximum wire size termination and torque rating:

- 0.0507 to 3.30 mm² (30 to 12 AWG) single-wire termination or two 1.31 mm² (16 AWG)
- 0.8 Nm (7.0 in-lb.) torque

Note:

Adjacent terminals may be labeled differently, depending on the model number.

Note:

To prevent damage to the controller, do not connect wires to unused terminals.

Note:

Maintain electrical isolation between digital input-outputs, switched dc/open collector outputs and process outputs to prevent ground loops.

Note:

If the last two digits of the part number are "12", this equipment is suitable for use in CLASS I, DIVISION 2, Groups A, B, C and D or Non-Hazardous locations only. Temperature Code T4



Warning:

Explosion Hazard – Substitution of component may impair suitability for CLASS I, DIVISION 2.



Warning:

Explosion Hazard - Do not disconnect while the circuit is live or unless the area is known to be free of ignitable concentrations of flammable substances.

Quad 2A SSR Outputs 1-4, 7-10, 13-16, 19 - 22

RME Part # Digit 5, 6, 7, 8 is L

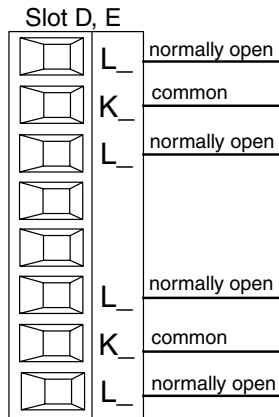

- 2 A at 20 to 264V~ (ac) maximum resistive load
- 50 VA 120/240V~ (ac) pilot duty
- Optical isolation, without contact suppression
- maximum off state leakage of 105 microamperes
- Output does not supply power.
- Do not use on dc loads.
- N.O., COM, N.O wiring (shared common) between each set of outputs.
- 100,000 cycle endurance tested resistive and pilot duty.
- See Quencharc note.

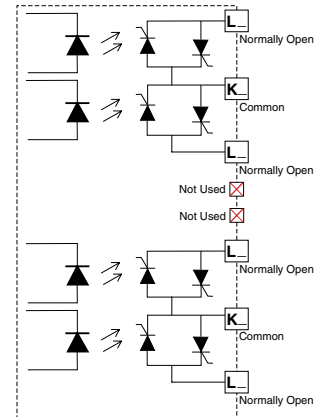

Quad 2 Amp SSR Derating Curve
All Outputs 100% Duty Cycle

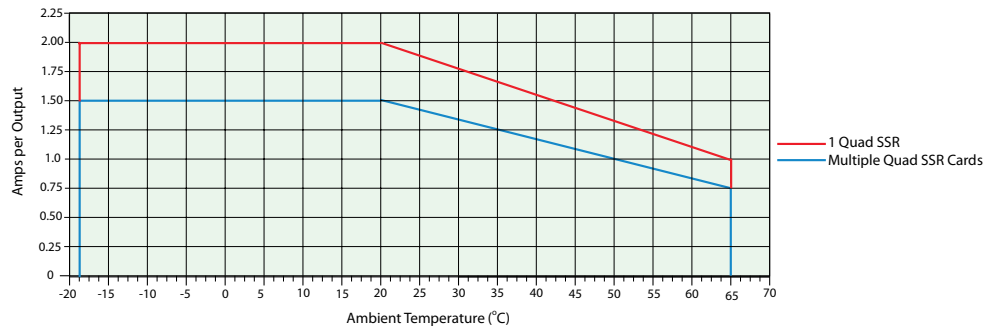

Note:

Each of the four SSR outputs has internal circuitry that will protect it from over heating. Outputs may be disabled (shut off) automatically if internal temperatures exceed those listed in the graph above. After the output temperature drops approximately 10 °C the outputs will once again be enabled for operation.

Tri-Process/Retransmit Outputs 1-3, 7-9, 13-15, 19-21

RME Part # Digit 5, 6, 7, 8 is F

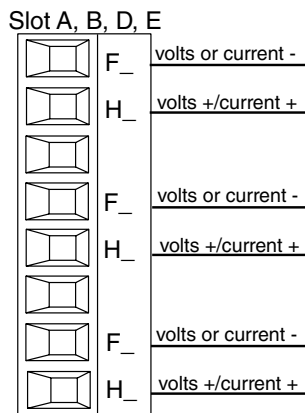

- 0 to 20 mA into 400Ω maximum load
- 0 to 10V= (dc) into 4 kΩ minimum load
- Outputs are scalable
- Output supplies power
- Each output can be independently set for voltage or current.
- Output may be used as retransmit or control.

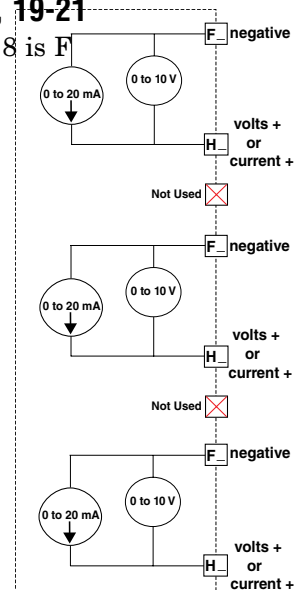

Warning: 

Use National Electric (NEC) or other country-specific standard wiring and safety practices when wiring and connecting this controller to a power source and to electrical sensors or peripheral devices. Failure to do so may result in damage to equipment and property, and/or injury or loss of life.

Note:

Maximum wire size termination and torque rating:

- 0.0507 to 3.30 mm² (30 to 12 AWG) single-wire termination or two 1.31 mm² (16 AWG)
- 0.8 Nm (7.0 in.-lb.) torque

Note:

Adjacent terminals may be labeled differently, depending on the model number.

Note:

To prevent damage to the controller, do not connect wires to unused terminals.

Note:

Maintain electrical isolation between digital input-outputs, switched dc/open collector outputs and process outputs to prevent ground loops.

Note:

If the last two digits of the part number are "12", this Equipment is suitable for use in CLASS I, DIVISION 2, Groups A, B, C and D or Non-Hazardous locations only. Temperature Code T4

Warning: 

Explosion Hazard – Substitution of component may impair suitability for CLASS I, DIVISION 2.

Warning: 

Explosion Hazard - Do not disconnect while the circuit is live or unless the area is known to be free of ignitable concentrations of flammable substances.

Standard Bus EIA-485 Communications

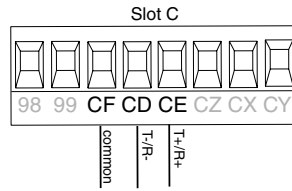

- Wire T-/R- to the A terminal of the EIA-485 port.
- Wire T+/R+ to the B terminal of the EIA-485 port.
- Wire common to the common terminal of the EIA-485 port.
- Do not route network wires with power wires. Connect network wires in daisy-chain fashion when connecting multiple devices in a network.
- A 120 Ω termination resistor may be required across T+/R+ and T-/R-, placed on the last controller on the network.
- Do not connect more than 16 EZ-ZONE RM controllers on a network.
- maximum network length: 1,200 meters (4,000 feet)
- 1/8th unit load on EIA-485 bus

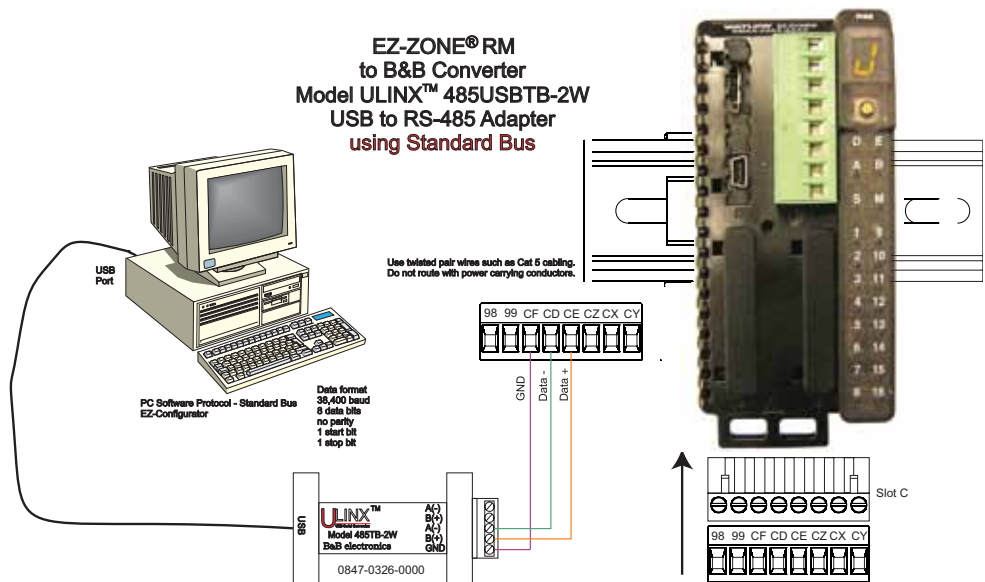

Note:

Do not leave a USB to EIA-485 converter connected to Standard Bus without power (i.e., disconnecting the USB end from the computer while leaving the converter connected on Standard Bus). Disturbance on the Standard Bus may



Warning:

Use National Electric (NEC) or other country-specific standard wiring and safety practices when wiring and connecting this controller to a power source and to electrical sensors or peripheral devices. Failure to do so may result in damage to equipment and property, and/or injury or loss of life.

Note:

Maximum wire size termination and torque rating:

- 0.0507 to 3.30 mm² (30 to 12 AWG) single-wire termination or two 1.31 mm² (16 AWG)
- 0.8 Nm (7.0 in-lb.) torque

Note:

Adjacent terminals may be labeled differently, depending on the model number.

Note:

To prevent damage to the controller, do not connect wires to unused terminals.

Note:

Maintain electrical isolation between digital input-outputs, switched dc/open collector outputs and process outputs to prevent ground loops.

Note:

If the last two digits of the part number are "12", this equipment is suitable for use in CLASS I, DIVISION 2, Groups A, B, C and D or Non-Hazardous locations only. Temperature Code T4



Warning:

Explosion Hazard – Substitution of component may impair suitability for CLASS I, DIVISION 2.



Warning:

Explosion Hazard - Do not disconnect while the circuit is live or unless the area is known to be free of ignitable concentrations of flammable substances.

occur.

Note:

When connecting the USB converter to the PC it is suggested that the Latency Timer be changed from the default of 16 msec to 1 msec. Failure to make this change may cause communication loss between the PC running ZE-ZONE Configurator software and the control.

To modify Latency Timer settings follow the steps below:

1. Navigate to Device Manager.
2. Double click on Ports.
3. Right click on the USB serial port in use and select Properties.
4. Click the tab labeled Port settings and then click the Advance button.

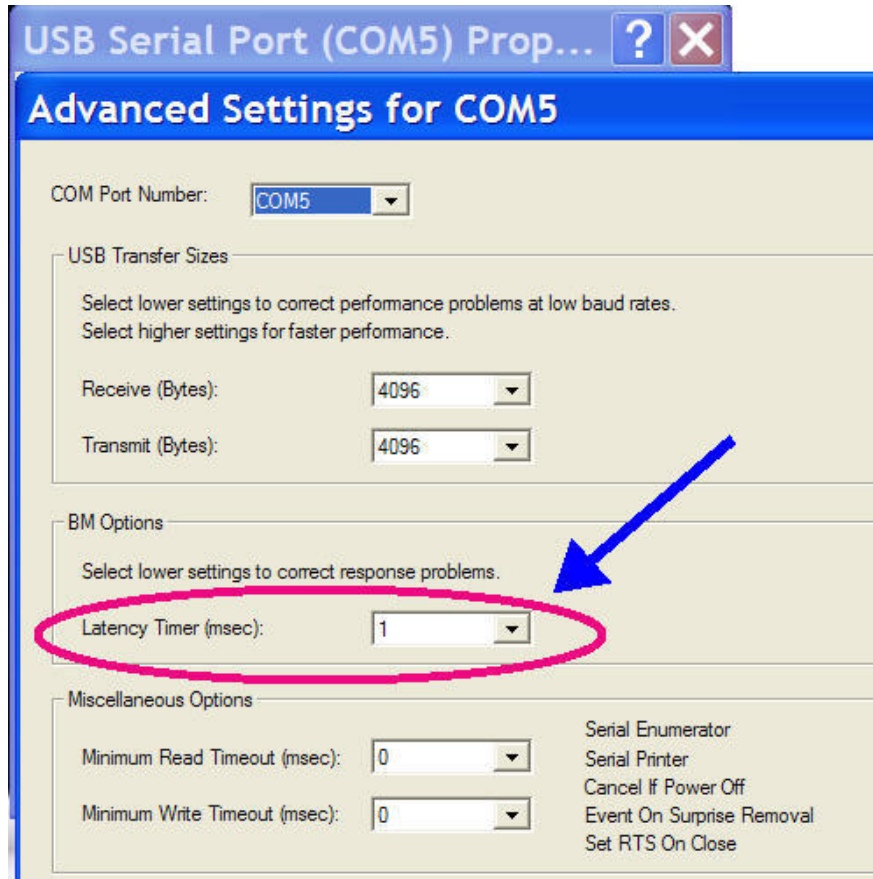

Connecting and Wiring the Modules

RM System Connections

Components of a RM system can be installed as stand-alone modules or can be interconnected on the DIN rail as shown below. When modules are connected together, power and communications are shared between modules over the modular backplane interconnection. Therefore, bringing the necessary power and communications wiring to any one connector in slot C is sufficient. The modular backplane interconnect comes standard with every module ordered and is generic in nature, meaning any of the RM modules shown below on the DIN rail can use it.

Modular backplane interconnect

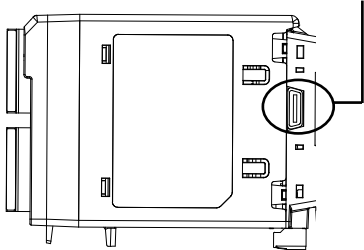

Notice in the split rail system diagram that a single power supply is being used across both DIN rails. One notable consideration when designing the hardware layout would be the available power supplied and the loading affect of all of the modules used. Watlow provides three options for power supplies listed below:

1. 90-264 Vac to 24Vdc @ 31 watts (Part #: 0847-0299-0000)
2. 90-264 Vac to 24Vdc @ 60 watts (Part #: 0847-0300-0000)
3. 90-264 Vac to 24Vdc @ 91 watts (Part #: 0847-0301-0000)

With regards to the modular loading affect, maximum power for each is listed below:

1. RMCxxxxxxxxxxxx @ 7 watts
2. RMEx-xxxx-xxxx @ 7 watts
3. RMAx-xxxx-xxxx @ 4 watts

So, in the split rail system diagram, the maximum current draw on the supply would be 38 Watts.

- 2 RMC modules consumes 14W
- 2 RME modules consumes 14W
- 1 RMA module consumes 4W
- 1 Remote User Interface consumes 6W

With this power requirement the second or third power supply could be used.

Another hardware configuration scenario that could present itself (graphic not shown) would be a configuration that requires more than one supply. Lets make some assumptions per-

taining to the split rail system diagram shown below. The power supply used is the 91W supply. The top DIN rail now has the following modules:

- 2 RMC modules consumes 14W
- 1 RMA consumes 4W
- 11 RME modules consumes 77W

As can now be seen, the total power requirement exceeds 91W. In this case, another power supply would be required. To incorporate another supply in this system simply disconnect pins 99 and 98 on the remote DIN rail and connect another appropriately sized power supply to those same pins.

When using a split rail configuration ensure that the interconnections for the Inter-module Bus and Standard Bus do not exceed 200 feet. Standard Bus and the Inter-module Buses are different protocols and both are required for split rail configurations. Without having both connected communications between modules would not be possible.

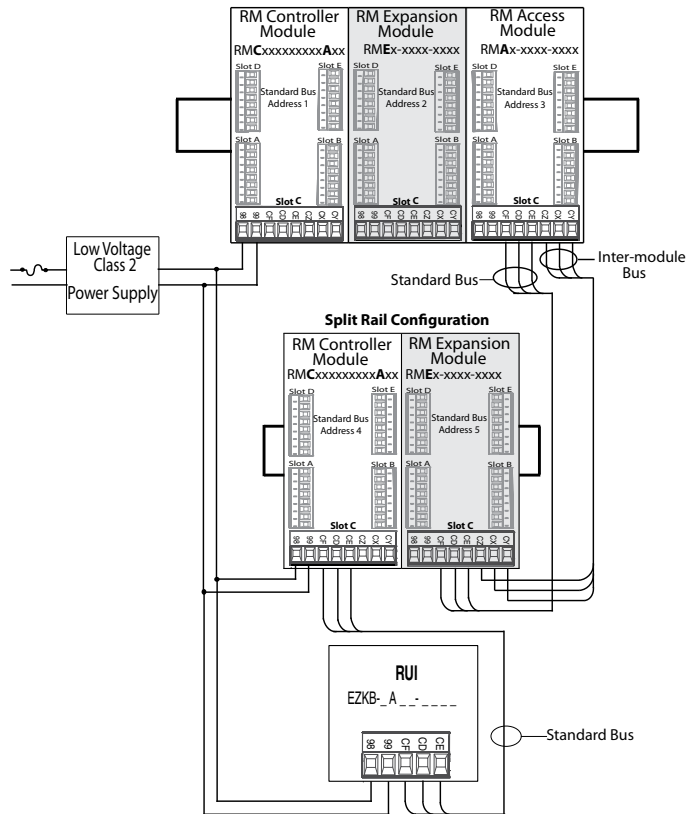

Note:

Module is not provided with a disconnect, use of an external disconnect is required. It should be located in close proximity to the module and be labeled as the disconnect for the module.

Note:

Connecting power supplies in parallel is not allowed. When power consumption is greater than 91 watts use a split rail configuration.

Conventions Used in the Menu Pages

To better understand the menu pages that follow review the naming conventions used. When encountered throughout this document, the word "default" implies as shipped from the factory. Each page (Operations, Setup and Factory) and their associated menus have identical headers defined below:

Note:

The communications protocols and associated addressing mentioned below and found in the menus are available only when another module equipped with the protocol is used in conjunction with the RME. The RME module by itself has Watlow's Standard Bus only.

Header Name	Definition
Display	Visually displayed information from the control.
Parameter Name	Describes the function of the given parameter.
Range	Defines options available for this prompt, i.e., min/max values (numerical), yes/no, etc... (further explanation below).
Default	Values as delivered from the factory.
Modbus Relative Address	Identifies unique parameters using either the Modbus RTU or Modbus TCP protocols.
CIP (Common Industrial Protocol)	Identifies unique parameters using either the DeviceNet or EtherNet/IP protocol (further explanation below).
Profibus Index	Identifies unique parameters using Profibus DP protocol (further explanation below).
Parameter ID	Identifies unique parameters used with other software such as, LabVIEW.
Data Type R/W	uint = Unsigned 16 bit integer dint = Signed 32-bit, long string = ASCII (8 bits per character) float = IEEE 754 32-bit RWES = R eadable W ritable E EPROM (saved) User S et (saved)

Display

When the RME module is used in conjunction with the RUI (optional equipment) visual information from the control is displayed to the observer using a fairly standard 7 segment display. Due to the use of this technology, several characters displayed need some interpretation, see the list below:

1 = 1	0 = 0	i = i	r = r
2 = 2	A = A	J = J	S = S
3 = 3	b = b	K = K	t = t
4 = 4	c , C = c	L = L	u = u
5 = 5	d = d	M = M	v = v
6 = 6	E = E	n = n	W = W
7 = 7	F = F	o = o	y = y
8 = 8	g = g	P = P	Z = Z
9 = 9	h = h	q = q	

Range

Within this column notice that on occasion there will be numbers found within parenthesis. This number represents the enumerated value for that particular selection. Range selections can be made simply by writing the enumerated value of choice using any of the available communications protocols. As an example, turn to the RME Setup Page and look at the Alarm Menu and then the Alarm Type. To turn the alarm off using Modbus simply write the value of 62 (off) to register 401469 and send that value to the control.

Communication Protocols

All modules come with the standard offering of Watlow's Standard Bus protocol used primarily for inter-module communications as well as for configuration using EZ-ZONE Configurator software (free download from Watlow's web site (<http://www.watlow.com>)). The RM Access (RMA) module and the RUI can serve as a gateway and have options for several different protocols listed below:

- Modbus RTU 232/485
- EtherNet/IP, Modbus TCP
- DeviceNet
- Profibus DP

To learn more about the RMA or RUI modules click on the link below. Once there simply type in RM in the Keyword field.

<http://www.watlow.com/literature/manuals.cfm>

3

Chapter 3: Operations Pages

Operation Page Parameters

To navigate to the Operations Page using the RUI, follow the steps below:

1. From the Home Page, press both the Up ▲ and Down ▼ keys for three seconds. [R] will appear in the upper display and [OPER] will appear in the lower display.
2. Press the Up ▲ or Down ▼ key to view available menus.
3. Press the Advance Key ⏩ to enter the menu of choice.
4. If a submenu exists (more than one instance), press

the Up ▲ or Down ▼ key to select and then press the Advance Key ⏩ to enter.

5. Press the Up ▲ or Down ▼ key to move through available menu prompts.
6. Press the Infinity Key ∞ to move backwards through the levels: parameter to submenu; submenu to menu; menu to Home Page.
7. Press and hold the Infinity Key ∞ for two seconds to return to the Home Page.

On the following pages, top level menus are identified with a yellow background color.

Note:

Some of these menus and parameters may not appear, depending on the controller's options. See model number information in the Appendix for more information. If there is only one instance of a menu, no submenus will appear.

Note:

Some of the listed parameters may not be visible. Parameter visibility is dependent upon controller part number.

[dio] Digital Input/Output Menu

[dio] Digital Input/Output (1 to 24)
[dos] Output State
[dis] Input State

[act] Action Menu

[act] Action (1 to 8)
[eis] Event Status

[alarm] Alarm Menu

[alarm] Alarm (1 to 8)
[alo] Low Set Point
[ah] High Set Point
[clr] Clear Request
[sreq] Silence Request
[st] State

[lin] Linearization Menu

[lin] Linearization (1 to 8)
[sva] Source Value A
[ofst] Offset
[ou] Output Value

[cpe] Compare Menu

[cpe] Compare (1 to 8)
[sva] Source Value A
[svb] Source Value B
[ou] Output Value

[tmr] Timer Menu

[tmr] Timer (1 to 8)
[sva] Source Value A
[svb] Source Value B
[et] Elapsed Time
[ou] Output Value

[ctr] Counter Menu

[ctr] Counter (1 to 8)
[cnt] Count
[sva] Source Value A
[svb] Source Value B
[ou] Output Value

[lgc] Logic Menu

[lgc] Logic (1 to 8)
[sva] Source Value A
[svb] Source Value B
[svc] Source Value C
[svd] Source Value D
[sve] Source Value E
[svf] Source Value F
[svg] Source Value G
[svh] Source Value H
[ou] Output Value

[math] Math Menu

[math] Math (1 to 8)
[sva] Source Value A
[svb] Source Value B

[svc] Source Value C
[svd] Source Value D
[sve] Source Value E
[ou] Output Value
[ofst] Offset

[sof] Special Output Function Menu

[sof] Special Output Function (1 to 4)
[sva] Source Value A
[svb] Source Value B
[ou1] Output Value 1
[ou2] Output Value 2
[ou3] Output Value 3
[ou4] Output Value 4

RME Module • Operations Page

Display	Parameter Name Description	Range	Default	Modbus Relative Address	CIP Class Instance Attribute hex (dec)	Profibus Index	Parameter ID	Data Type & Read/Write
<p>do oPEr</p> <p>Digital Input / Output Menu</p>								
do.S [do.S]	<i>Digital Output (1 to 24)</i> Output State View the state of this output.	<input type="checkbox"/> oFF Off (62) <input type="checkbox"/> oN On (63)	----	372 [off 30]	0x6A (106) 1 to 18 (24) 7	28	6007	uint R
di.S [di.S]	<i>Digital Input (1 to 24)</i> Input State View this event input state.	<input type="checkbox"/> oFF Off (62) <input type="checkbox"/> oN On (63)	----	380 [off 30]	0x6A (106) 1 to 18 (24) 0xB (11)	----	6011	uint R
No Display	<i>Digital Input (1 to 24)</i> Source Error View reported cause for input malfunction.	None (61) Open (65) Shorted (127) Measurement error (140) Bad calibration data (139) Ambient error (9) RTD error (14) Fail (32) Math error (1423) Not sourced (246) Stale (1617)	----	388 [offset 30]	0x6A (106) 1 to 18 (24) 0x0F (15)	----	6015	uint R
<p>Act oPEr</p> <p>Action Menu</p>								
Ei.S [Ei.S]	<i>Action (1 to 8)</i> Event Status View this input state.	<input type="checkbox"/> oFF Off (62) <input type="checkbox"/> oN On (63)	----	1288 [off 20]	0x6E (110) 1 to 8 5	74	10005	uint R
<p>ALP oPEr</p> <p>Alarm Menu</p>								
ALo [A.Lo]	<i>Alarm (1 to 8)</i> Low Set Point If Alarm Type (Setup Page, Alarm Menu) is set to: process - set the process value that will trigger a low alarm.	-1,999.000 to 9,999.000°F or units -1,128.000 to 5,537.000°C	32.0°F or units 0.0°C	1442 [off 60]	0x6D (109) 1 to 8 2	0	9002	float RWES
Ahi [A.hi]	<i>Alarm (1 to 8)</i> High Set Point If Alarm Type (Setup Page, Alarm Menu) is set to: process - set the process value that will trigger a high alarm.	-1,999.000 to 9,999.000°F or units -1,128.000 to 5,537.000°C	300.0°F or units 150.0°C	1440 [off 60]	0x6D (109) 1 to 8 1	1	9001	float RWES
ALr [A.CLr]	<i>Alarm (1 to 8)</i> Alarm Clear Request Write to this register to clear an alarm	0	None	1464 [offset 60]	0x6D (109) 1 to 8 0xD (13)	14	9013	uint W
<p>Note: Some values will be rounded off to fit in the four-character display. Full values can be read with other interfaces.</p> <p>Note: If there is only one instance of a menu, no submenus will appear.</p> <p>** These parameters/prompts are available in these menus with firmware revisions 6.0 and above.</p>								R: Read W: Write E: EE-PROM S: User Set

RME Module • Operations Page

Display	Parameter Name Description	Range	Default	Modbus Relative Address	CIP Class Instance Attribute hex (dec)	Profibus Index	Param- eter ID	Data Type & Read/ Write
<input type="checkbox"/> RS <input type="checkbox"/> r [A.Sir]	<i>Alarm (1 to 4)</i> Alarm Silence Request Write to this register to silence an alarm	0	None	1466 [offset 60]	0x6D (109) 1 to 8 0xE (14)	15	9014	uint W
<input type="checkbox"/> RSE [A.St]	<i>Alarm (1 to 8)</i> Alarm State View state of alarm	Startup (88) None (61) Blocked (12) Alarm low (8) Alarm high (7) Error (28)	None	1456 [offset 60]	0x6D (109) 1 to 8 9	----	9009	uint R
No Display	<i>Alarm (1 to 4)</i> Alarm Clearable Read to determine if alarm can be cleared.	<input type="checkbox"/> no No (59) <input type="checkbox"/> YES Yes (106)	None	1462 [offset 60]	0x6D (109) 1 to 8 0xC (12)	----	9012	uint R
No Display	<i>Alarm (1 to 8)</i> Silenced Read to see if alarm is active but has been silenced by Alarm Silence Request.	Yes (106) No (59)	----	1460 [offset 60]	0x6D (109) 1 to 4 0x0B (11)	----	9011	uint R
No Display	<i>Alarm (1 to 8)</i> Latched Read to see if alarm is currently latched.	Yes (106) No (59)	----	1458 [offset 60]	0x6D (109) 1 to 4 0x0A (10)	----	9010	uint R
<input type="checkbox"/> Lnr <input type="checkbox"/> oPEr Linearization Menu								
<input type="checkbox"/> SuA [Su.A]	<i>Linearization (1 to 8)</i> Source Value A View the value of Source A.	-1,999.000 to 9,999.000°F or units -1,128.000 to 5,537.000°C	----	5546 [off 70]	0x86 (134) 1 to 8 4	----	34004	float R
<input type="checkbox"/> oFSt [oFSt]	<i>Linearization (1 to 8)</i> Offset Set an offset to be applied to this function's output.	-1,999.000 to 9,999.000°F or units -1,128.000 to 5,537.000°C	0	5550 [off 70]	0x86 (134) 1 to 8 6	----	34006	float RWES
<input type="checkbox"/> oV [o.v]	<i>Linearization (1 to 8)</i> Output Value View the value of this function's output.	-1,999.000 to 9,999.000°F or units -1,128.000 to 5,537.000°C	----	5552 [off 70]	0x86 (134) 1 to 8 7	----	34007	float R
No Display	<i>Linearization (1 to 8)</i> Error Read reported cause for linearization error.	None (61) Open (65) Shorted (127) Measurement error (140) Bad calibration data (139) Ambient error (9) RTD error (14) Fail (32) Math error (1423) Not sourced (246) Stale (1617) Can't process (1659)	----	5594 [offset 70]	0x86 (134) 1 to 8 0x1C (28)	----	34028	uint R
<p>Note: Some values will be rounded off to fit in the four-character display. Full values can be read with other interfaces.</p> <p>Note: If there is only one instance of a menu, no submenus will appear.</p> <p>** These parameters/prompts are available in these menus with firmware revisions 6.0 and above.</p>								R: Read W: Write E: EE-PROM S: User Set

RME Module • Operations Page

Display	Parameter Name Description	Range	Default	Modbus Relative Address	CIP Class Instance Attribute hex (dec)	Profibus Index	Parameter ID	Data Type & Read/Write
<input type="checkbox"/> CPE <input type="checkbox"/> oPEr Compare Menu								
<input type="checkbox"/> Su.A [Su.A]	<i>Compare (1 to 8)</i> Source Value A View the value of Source A.	-1,999.000 to 9,999.000°F or units -1,128.000 to 5,537.000°C	----	3992 [off 40]	0x80 (128) 1 to 8 7	----	28007	float R
<input type="checkbox"/> Su.b [Su.b]	<i>Compare (1 to 8)</i> Source Value B View the value of Source B.	-1,999.000 to 9,999.000°F or units -1,128.000 to 5,537.000°C	----	3994 [off 40]	0x80 (128) 1 to 8 8	----	28008	float R
<input type="checkbox"/> o.v [o.v]	<i>Compare (1 to 8)</i> Output Value View the value of this function's output.	<input type="checkbox"/> oFF Off (62) <input type="checkbox"/> oN On (63)	----	3998 [off 40]	0x80 (128) 1 to 8 0xA (10)	----	28010	uint R
No Display	<i>Compare (1 to 8)</i> Error Read reported cause for compare error	None (61) Open (65) Shorted (127) Measurement error (140) Bad Cal Data (139) Ambient Error (9) RTD Error (141) Fail (32) Math Error (1423) Not Sourced (246) Stale (1617)	----	4004 [offset 40]	0x80 (128) 1 to 8 0x0D (13)	----	28013	uint R
<input type="checkbox"/> ETt <input type="checkbox"/> oPEr Timer Menu								
<input type="checkbox"/> Su.A [Su.A]	<i>Timer (1 to 8)</i> Source Value A View the value of Source A.	<input type="checkbox"/> oFF Off (62) <input type="checkbox"/> oN On (63)	----	4952 [off 50]	0x83 (131) 1 to 8 7	----	31007	uint R
<input type="checkbox"/> Su.b [Su.b]	<i>Timer (1 to 8)</i> Source Value B View the value of Source B.	<input type="checkbox"/> oFF Off (62) <input type="checkbox"/> oN On (63)	----	4954 [off 50]	0x83 (131) 1 to 8 8	----	31008	uint R
<input type="checkbox"/> E.t [E.t]	<i>Timer (1 to 8)</i> Elapsed Time View the value of this function's elapsed time.	0.0 to 30,000.000 seconds	----	4970 [off 50]	0x83 (131) 1 to 8 0x10 (16)	----	31016	float R
<input type="checkbox"/> o.v [o.v]	<i>Timer (1 to 8)</i> Output Value View the value of this function's output.	<input type="checkbox"/> oFF Off (62) <input type="checkbox"/> oN On (63)	----	4958 [off 50]	0x83 (131) 1 to 8 0xA (10)	----	31010	uint R
Note: Some values will be rounded off to fit in the four-character display. Full values can be read with other interfaces. Note: If there is only one instance of a menu, no submenus will appear. ** These parameters/prompts are available in these menus with firmware revisions 6.0 and above.								R: Read W: Write E: EE-PROM S: User Set

RME Module • Operations Page

Display	Parameter Name Description	Range	Default	Modbus Relative Address	CIP Class Instance Attribute hex (dec)	Profibus Index	Parameter ID	Data Type & Read/Write
No Display	<i>Timer (1 to 8)</i> Error Read reported cause for timer error	None (61) Open (65) Shorted (127) Measurement error (140) Bad Cal Data (139) Ambient Error (9) RTD Error (141) Fail (32) Math Error (1423) Not Sourced (246) Stale (1617)	----	4974 [offset 50]	0x83 (131) 1 to 8 0x12 (18)	----	31018	uint R

CEr
 oPEr

Counter Menu

<input type="checkbox"/> Cnt [Cnt]	<i>Counter (1 to 8)</i> Count View the function's total count.	0 to 9,999	----	4488 [off 40]	0x82 (130) 1 to 8 0xF (15)	143	30015	uint R
<input type="checkbox"/> SuA [Su.A]	<i>Counter (1 to 8)</i> Source Value A View the value of Source A.	<input type="checkbox"/> oFF Off (62) <input type="checkbox"/> oN On (63)	----	4472 [off 40]	0x82 (130) 1 to 8 7	----	30007	uint R
<input type="checkbox"/> SuB [Su.b]	<i>Counter (1 to 8)</i> Source Value B View the value of Source B.	<input type="checkbox"/> oFF Off (62) <input type="checkbox"/> oN On (63)	----	4474 [off 40]	0x82 (130) 1 to 8 8	----	30008	uint R
<input type="checkbox"/> o.v [o.v]	<i>Counter (1 to 8)</i> Output Value View the value of this function's output.	<input type="checkbox"/> oFF Off (62) <input type="checkbox"/> oN On (63)	----	4478 [off 40]	0x82 (130) 1 to 8 0xA (10)	----	30010	uint R
No Display	<i>Counter (1 to 8)</i> Error Read reported cause for counter error	None (61) Open (65) Shorted (127) Measurement error (140) Bad Cal Data (139) Ambient Error (9) RTD Error (141) Fail (32) Math Error (1423) Not Sourced (246) Stale (1617)	----	4490 [offset 40]	0x82 (130) 1 to 8 0x10 (16)	----	30016	uint R

L9C
 oPEr

Logic Menu

<input type="checkbox"/> SuA [Su.A]	<i>Logic (1 to 8)</i> Source Value A View the value of Source A.	<input type="checkbox"/> oFF Off (62) <input type="checkbox"/> oN On (63)	----	3068 [off 80]	0x7F (127) 1 to 8 0x19 (25)	----	27025	uint R
<p>Note: Some values will be rounded off to fit in the four-character display. Full values can be read with other interfaces.</p> <p>Note: If there is only one instance of a menu, no submenus will appear.</p> <p>** These parameters/prompts are available in these menus with firmware revisions 6.0 and above.</p>								R: Read W: Write E: EE-PROM S: User Set



RME Module • Operations Page

Display	Parameter Name Description	Range	Default	Modbus Relative Address	CIP Class Instance Attribute hex (dec)	Profibus Index	Parameter ID	Data Type & Read/Write
<input type="checkbox"/> Su.b [Su.b]	<i>Logic (1 to 8)</i> Source Value B View the value of Source B.	<input type="checkbox"/> oFF Off (62) <input type="checkbox"/> oN On (63)	----	3070 [off 80]	0x7F (127) 1 to 8 0x1A (26)	----	27026	uint R
<input type="checkbox"/> Su.C [Su.C]	<i>Logic (1 to 8)</i> Source Value C View the value of Source C.	<input type="checkbox"/> oFF Off (62) <input type="checkbox"/> oN On (63)	----	3072 [off 80]	0x7F (127) 1 to 8 0x1B (27)	----	27027	uint R
<input type="checkbox"/> Su.d [Su.d]	<i>Logic (1 to 8)</i> Source Value D View the value of Source D.	<input type="checkbox"/> oFF Off (62) <input type="checkbox"/> oN On (63)	----	3074 [off 80]	0x7F (127) 1 to 8 0x1C (28)	----	27028	uint R
<input type="checkbox"/> Su.E [Su.E]	<i>Logic (1 to 8)</i> Source Value E View the value of Source E.	<input type="checkbox"/> oFF Off (62) <input type="checkbox"/> oN On (63)	----	3076 [off 80]	0x7F (127) 1 to 8 0x1D (29)	----	27029	uint R
<input type="checkbox"/> Su.F [Su.F]	<i>Logic (1 to 8)</i> Source Value F View the value of Source F.	<input type="checkbox"/> oFF Off (62) <input type="checkbox"/> oN On (63)	----	3078 [off 80]	0x7F (127) 1 to 8 0x1E (30)	----	27030	uint R
<input type="checkbox"/> Su.g [Su.g]	<i>Logic (1 to 8)</i> Source Value G View the value of Source G.	<input type="checkbox"/> oFF Off (62) <input type="checkbox"/> oN On (63)	----	3080 [off 80]	0x7F (127) 1 to 8 0x1F (31)	----	27031	uint R
<input type="checkbox"/> Su.h [Su.h]	<i>Logic (1 to 8)</i> Source Value H View the value of Source H.	<input type="checkbox"/> oFF Off (62) <input type="checkbox"/> oN On (63)	----	3082 [off 80]	0x7F (127) 1 to 8 0x20 (32)	----	27032	uint R
<input type="checkbox"/> o.u [o.v]	<i>Logic (1 to 8)</i> Output Value View the value of this function's output.	<input type="checkbox"/> oFF Off (62) <input type="checkbox"/> oN On (63)	----	3086 [off 80]	0x7F (127) 1 to 8 0x22 (34)	----	27034	uint R
No Display	<i>Logic (1 to 8)</i> Error Read reported cause for logic error	None (61) Open (65) Shorted (127) Measurement error (140) Bad Cal Data (139) Ambient Error (9) RTD Error (141) Fail (32) Math Error (1423) Not Sourced (246) Stale (1617)	----	3090 [offset 80]	0x7F (127) 1 to 4 0x24 (36)	----	27036	uint R
<p>OPER</p> <p>oPER</p> <p>Math Menu</p>								
<input type="checkbox"/> Su.A [Su.A]	<i>Math (1 to 8)</i> Source Value A View the value of Source A.	-1,999.000 to 9,999.000°F or units -1,128.000 to 5,537.000°C	----	2210 [off 70]	0x7D (125) 1 to 8 0x10 (16)	----	25016	float R
<p>Note: Some values will be rounded off to fit in the four-character display. Full values can be read with other interfaces.</p> <p>Note: If there is only one instance of a menu, no submenus will appear.</p> <p>** These parameters/prompts are available in these menus with firmware revisions 6.0 and above.</p>								<p>R: Read W: Write E: EE-PROM S: User Set</p>

RME Module • Operations Page

Display	Parameter Name Description	Range	Default	Modbus Relative Address	CIP Class Instance Attribute hex (dec)	Profibus Index	Param- eter ID	Data Type & Read/ Write
<input type="checkbox"/> Su.B [Su.b]	<i>Math (1 to 8)</i> Source Value B View the value of Source B.	-1,999.000 to 9,999.000°F or units -1,128.000 to 5,537.000°C	----	2212 [off 70]	0x7D (125) 1 to 8 0x11 (17)	----	25017	float R
<input type="checkbox"/> Su.C [Su.C]	<i>Math (1 to 8)</i> Source Value C View the value of Source C.	-1,999.000 to 9,999.000°F or units -1,128.000 to 5,537.000°C	----	2214 [off 70]	0x7D (125) 1 to 8 0x12 (18)	----	25018	float R
<input type="checkbox"/> Su.d [Su.d]	<i>Math (1 to 8)</i> Source Value D View the value of Source D.	-1,999.000 to 9,999.000°F or units -1,128.000 to 5,537.000°C	----	2216 [off 70]	0x7D (125) 1 to 8 0x13 (19)	----	25019	float R
<input type="checkbox"/> Su.E [Su.E]	<i>Math (1 to 8)</i> Source Value E View the value of Source E.	<input type="checkbox"/> OFF Off (62) <input type="checkbox"/> ON On (63)	----	2218 [off 70]	0x7D (125) 1 to 8 0x14 (20)	----	25020	uint R
<input type="checkbox"/> oFSt [oFSt]	<i>Math (1 to 8)</i> Offset Set an offset to be applied to this function's output.	-1,999.000 to 9,999.000°F or units -1,128.000 to 5,537.000°C	0	2224 [off 70]	0x7D (125) 1 to 8 0x17 (23)	----	25023	float RWES
<input type="checkbox"/> o.v [o.v]	<i>Math (1 to 8)</i> Output Value View the value of this function's output.	-1,999.000 to 9,999.000°F or units -1,128.000 to 5,537.000°C	----	2222 [off 70]	0x7D (125) 1 to 8 0x16 (22)	----	25022	float R
No Display	<i>Math (1 to 8)</i> Error Read reported cause for math error.	None (61) Open (65) Shorted (127) Measurement error (140) Bad Cal Data (139) Ambient Error (9) RTD Error (141) Fail (32) Math Error (1423) Not Sourced (246) Stale (1617)	----	2236 [offset 70]	0x7D (125) 1 to 8 0x1D (29)	----	25029	uint R
<input type="checkbox"/> SoF <input type="checkbox"/> oPEr Special Output Function Menu								
<input type="checkbox"/> Su.A [Su.A]	<i>Special Output Function (1 to 4)</i> Source Value A View the value of Source A.	-1,999.000 to 9,999.000°F or units -1,128.000 to 5,537.000°C	----	6632 [off 80]	0x87 (135) 1 to 4 7	----	35007	float R
<input type="checkbox"/> Su.b [Su.b]	<i>Special Output Function (1 to 4)</i> Source Value B View the value of Source B.	-1,999.000 to 9,999.000°F or units -1,128.000 to 5,537.000°C	----	6634 [off 80]	0x87 (135) 1 to 4 8	----	35008	float R
Note: Some values will be rounded off to fit in the four-character display. Full values can be read with other interfaces. Note: If there is only one instance of a menu, no submenus will appear. ** These parameters/prompts are available in these menus with firmware revisions 6.0 and above.								R: Read W: Write E: EE-PROM S: User Set

RME Module • Operations Page

Display	Parameter Name Description	Range	Default	Modbus Relative Address	CIP Class Instance Attribute hex (dec)	Profibus Index	Parameter ID	Data Type & Read/Write
 [o.v1]	<i>Special Output Function (1 to 4)</i> Output Value 1 View the value of this function's Output 1.	-1,999.000 to 9,999.000°F or units -1,128.000 to 5,537.000°C	----	6638 [off 80]	0x87 (135) 1 to 4 0xA (10)	----	35010	float R
No Display	<i>Special Output Function (1 to 4)</i> Error 1 Read reported cause for output error.	None (61) Open (65) Shorted (127) Measurement error (140) Bad calibration data (139) Ambient error (9) RTD error (14) Fail (32) Math error (1423) Not sourced (246) Stale (1617) Can't process (1659)	----	6640 [offset 80]	0x87 (135) 1 to 4 0x0B (11)	----	35011	uint R
 [o.v2]	<i>Special Output Function (1 to 4)</i> Output Value 2 View the value of this function's Output 2.	-1,999.000 to 9,999.000°F or units -1,128.000 to 5,537.000°C	----	6642 [off 80]	0x87 (135) 1 to 4 0xC (12)	----	35012	float R
No Display	<i>Special Output Function (1 to 4)</i> Error 2 Read reported cause for output error.	None (61) Open (65) Shorted (127) Measurement error (140) Bad calibration data (139) Ambient error (9) RTD error (14) Fail (32) Math error (1423) Not sourced (246) Stale (1617) Can't process (1659)	----	6644 [offset 80]	0x87 (135) 1 to 4 0x0D (13)	----	35013	uint R
 [o.v3]	<i>Special Output Function (1 to 4)</i> Output Value 3 View the value of this function's Output 3.	-1,999.000 to 9,999.000°F or units -1,128.000 to 5,537.000°C	----	6646 [off 80]	0x87 (135) 1 to 4 0xE (14)	----	35014	float R
No Display	<i>Special Output Function (1 to 4)</i> Error 3 Read reported cause for output error.	None (61) Open (65) Shorted (127) Measurement error (140) Bad calibration data (139) Ambient error (9) RTD error (14) Fail (32) Math error (1423) Not sourced (246) Stale (1617) Can't process (1659)	----	6648 [offset 80]	0x87 (135) 1 to 4 0x0F (15)	----	35015	uint R
<p>Note: Some values will be rounded off to fit in the four-character display. Full values can be read with other interfaces.</p> <p>Note: If there is only one instance of a menu, no submenus will appear.</p> <p>** These parameters/prompts are available in these menus with firmware revisions 6.0 and above.</p>								R: Read W: Write E: EE-PROM S: User Set

RME Module • Operations Page

Display	Parameter Name Description	Range	Default	Modbus Relative Address	CIP Class Instance Attribute hex (dec)	Profibus Index	Parameter ID	Data Type & Read/Write
<div style="border: 1px solid black; padding: 2px; display: inline-block;"> 0.04 [o.v4] </div>	<i>Special Output Function (1 to 4)</i> Output Value 4 View the value of this function's Output 4.	-1,999.000 to 9,999.000°F or units -1,128.000 to 5,537.000°C	----	6650 [off 80]	0x87 (135) 1 to 4 0x10 (16)	----	35016	float R
No Display	<i>Special Output Function (1 to 4)</i> Error 4 Read reported cause for output error.	None (61) Open (65) Shorted (127) Measurement error (140) Bad calibration data (139) Ambient error (9) RTD error (14) Fail (32) Math error (1423) Not sourced (246) Stale (1617) Can't process (1659)	----	6652 [offset 80]	0x87 (135) 1 to 4 0x11 (17)	----	35017	uint R
Note: Some values will be rounded off to fit in the four-character display. Full values can be read with other interfaces. Note: If there is only one instance of a menu, no submenus will appear. ** These parameters/prompts are available in these menus with firmware revisions 6.0 and above.								R: Read W: Write E: EE-PROM S: User Set

4

Chapter 4: Setup Pages

Setup Page Parameters

To navigate to the Setup Page using the RUI, follow the steps below:

1. From the Home Page, press both the Up ▲ and Down ▼ keys for six seconds. [R] will appear in the upper display and [SEE] will appear in the lower display.
2. Press the Up ▲ or Down ▼ key to view available menus.
3. Press the Advance Key Ⓢ to enter the menu of choice.
4. If a submenu exists (more than one instance), press

the Up ▲ or Down ▼ key to select and then press the Advance Key Ⓢ to enter.

5. Press the Up ▲ or Down ▼ key to move through available menu prompts.
6. Press the Infinity Key ∞ to move backwards through the levels: parameter to submenu; submenu to menu; menu to Home Page.
7. Press and hold the Infinity Key ∞ for two seconds to return to the Home Page.

On the following pages, top level menus are identified with a yellow background color.

Note:

Some of these menus and parameters may not appear, depending on the controller's options. See model number information in the Appendix for more information. If there is only one instance of a menu, no submenus will appear.

Note:

Some of the listed parameters may not be visible. Parameter visibility is dependent upon controller part number.

[d.i.o]	[F.i] Function Instance	[Units]
[SEE] Digital Input/Output Menu	[SZ.A] Source Zone A	[i.P.1] Input Point 1
[]	[S.Lo] Scale Low	[o.P.1] Output Point 1
[d.i.o] Digital Input/Output (1 to 24)	[S.H.i] Scale High	[i.P.2] Input Point 2
[d.i.r] Direction	[r.Lo] Range Low	[o.P.2] Output Point 2
[F.n] Function	[r.H.i] Range High	[i.P.3] Input Point 3
[F.i] Function Instance	[o.C.R] Calibration Offset	[o.P.3] Output Point 3
[SZ.A] Source Zone A		[i.P.4] Input Point 4
[o.C.t] Control	[ALP.A]	[o.P.4] Output Point 4
[o.t.b] Time Base	[SEE] Alarm Menu	[i.P.5] Input Point 5
[o.L.o] Low Power Scale	[]	[o.P.5] Output Point 5
[o.h.i] High Power Scale	[ALP.A] Alarm (1 to 8)	[i.P.6] Input Point 6
	[A.t.y] Type	[o.P.6] Output Point 6
[A.C.t] Action Menu	[S.r.A] Source	[i.P.7] Input Point 7
[SEE] Action Menu	[i.S.A] Source Instance	[o.P.7] Output Point 7
[]	[SZ.A] Source Zone	[i.P.8] Input Point 8
[A.C.t] Action (1 to 8)	[A.h.y] Hysteresis	[o.P.8] Output Point 8
[F.n] Function	[A.L.g] Logic	[i.P.9] Input Point 9
[F.i] Function Instance	[A.S.d] Sides	[o.P.9] Output Point 9
[SF.n.A] Source Function A	[A.L.o] Low Set Point **	[i.P.10] Input Point 10
[S.i.A] Source Instance A	[A.h.i] High Set Point **	[o.P.10] Output Point 10
[SZ.A] Source Zone A	[A.L.A] Latching	
[L.E.v] Active Level	[A.b.L] Blocking	[C.P.E]
[o.t.P.t] Output Menu	[A.S.i] Silencing	[SEE] Compare Menu
[SEE] Output Menu	[A.d.S.P] Display	[]
[]	[A.d.L] Delay Time	[C.P.E] Compare (1 to 8)
[o.t.P.t] Output (1 to 24)	[A.C.L.r] Clear Request **	[F.n] Function
[F.n] Function	[A.S.i.r] Silence Request **	[t.o.l] Tolerance
[F.i] Function Instance	[A.S.t] State **	[SF.n.A] Source Function A
[SZ.A] Source Zone A		[S.i.A] Source Instance A
[o.C.t] Control	[L.n.r]	[SZ.A] Source Zone A
[o.t.b] Time Base	[SEE] Linearization Menu	[SF.n.B] Source Function B
[o.L.o] Low Power Scale	[]	[S.i.B] Source Instance B
[o.h.i] High Power Scale	[L.n.r] Linearization (1 to 8)	[SZ.B] Source Zone B
[o.t.P.t] Output 1-3, 7-9, 13-15, 19-21 process	[F.n] Function	[E.r.h] Error Handling
[o.t.y] Type	[SF.n.A] Source Function A	
[F.n] Function	[S.i.A] Source Instance A	
	[SZ.A] Source Zone A	

- ETTR**
- SEE** Timer Menu
 - i**
 - ETTR** Timer (1 to 8)
 - Fn** Function
 - SFnA** Source Function A
 - SiA** Source Instance A
 - SZA** Source Zone A
 - SASA** Source Active State A
 - SFnB** Source Function B
 - SiB** Source Instance B
 - SZB** Source Zone B
 - SASB** Source Active State B
 - t** Time
 - LEW** Active Level
- CTC**
- SEE** Counter Menu
 - i**
 - CTC** Counter (1 to 8)
 - Fn** Function
 - SFnA** Source Function A
 - SiA** Source Instance A
 - SZA** Source Zone A
 - SASA** Source Active State A
 - SFnB** Source Function B
 - SiB** Source Instance B
 - SZB** Source Zone B
 - SASB** Source Active State B
 - Load** Load Value
 - trgt** Target Value
 - LRE** Latching
- L9C**
- SEE** Logic Menu
 - i**
 - L9C** Logic (1 to 8)
 - Fn** Function
 - SFnA** Source Function A
 - SiA** Source Instance A
 - SZA** Source Zone A
 - SFnB** Source Function B
 - SiB** Source Instance B
 - SZB** Source Zone B
 - SFnC** Source Function C
 - SiC** Source Instance C
 - SZC** Source Zone C
 - SFnD** Source Function D
 - SiD** Source Instance D
 - SZD** Source Zone D
 - SFnE** Source Function E
 - SiE** Source Instance E
 - SZE** Source Zone E
 - SFnF** Source Function F
 - SiF** Source Instance F
 - SZF** Source Zone F
 - SFnG** Source Function G
 - SiG** Source Instance G
 - SZG** Source Zone G
 - SFnH** Source Function H
 - SiH** Source Instance H
 - SZH** Source Zone H
 - Errh** Error Handling
- P7RE**
- SEE** Math Menu
 - i**
 - P7RE** Math (1 to 8)
 - Fn** Function
 - SFnA** Source Function A
 - SiA** Source Instance A
 - SZA** Source Zone A
 - SFnB** Source Function B
- SiB** Source Instance B
- SZB** Source Zone B
- SFnC** Source Function C
- SiC** Source Instance C
- SZC** Source Zone C
- SFnD** Source Function D
- SiD** Source Instance D
- SZD** Source Zone D
- SFnE** Source Function E
- SiE** Source Instance E
- SZE** Source Zone E
- SLo** Scale Low
- SHi** Scale High
- Units** Units
- rLo** Range Low
- rHi** Range High
- Pressure** Pressure Units
- Altitude** Altitude Units
- Filter** Filter
- SOF**
- SEE** Special Output Function Menu
 - i**
 - SOF** Special Output Function (1 to 4)
 - Fn** Function
 - SFnA** Source Function A
 - SiA** Source Instance A
 - SZA** Source Zone A
 - SFnB** Source Function B
 - SiB** Source Instance B
 - SZB** Source Zone B
 - POnA** Power On Level 1
 - POFA** Power Off Level 1
 - POnB** Power On Level 2
 - POFB** Power Off Level 2
 - OnT** On Time
 - OffT** Off Time
 - tT** Valve Travel Time
 - db** Dead Band
 - o5.1** Output 1 Size
 - o5.2** Output 2 Size
 - o5.3** Output 3 Size
 - o5.4** Output 4 Size
 - EdL** Time Delay
 - oEo** Output Order
- uAr**
- SEE** Variable Menu
 - i**
 - uAr** Variable (1 to 8)
 - TYPE** Data Type
 - Units** Units
 - d.9** Digital
 - RnL9** Analog
- 9LbL**
- SEE** Global Menu
 - C-F** Display Units
 - ACLF** AC Line Frequency
 - dPr5** Display Pairs
 - USr.5** User Settings Save
 - USr.r** User Settings Restore

RME Module • Setup Page

Display	Parameter Name Description	Range	Default	Modbus Relative Address	CIP Class Instance Attribute hex (dec)	Profibus Index	Parameter ID	Data Type & Read/Write
<p>d.i.o SEt</p> <p>Digital Input / Output Menu</p>								
d.i.r [dir]	<i>Digital Input/Output (1 to 24)</i> Direction Set this function to operate as an input or output.	<p>oFF Output (68)</p> <p>i.n Input Voltage (193)</p> <p>i.con Input Dry Contact (44)</p>	Output	360 [offset 30]	0x6A (106) 1 to (24) 1	82	6001	uint RWES
Fn [Fn]	<i>Digital Output (1 to 24)</i> Function Select what function will drive this output.	<p>oFF Off (62)</p> <p>R Analog Input (142)</p> <p>ALn Alarm (6)</p> <p>CPr Cool Power, Control Loop (161)</p> <p>hPr Heat Power, Control Loop (160)</p> <p>CPE Compare (230)</p> <p>Ctr Counter (231)</p> <p>d.i.o Digital I/O (1142)</p> <p>Ent.a Profile Event Out A (233)</p> <p>Ent.b Profile Event Out B (234)</p> <p>Ent.c Profile Event Out C (235)</p> <p>Ent.d Profile Event Out D (236)</p> <p>Ent.e Profile Event Out E (247)</p> <p>Ent.f Profile Event Out F (248)</p> <p>Ent.g Profile Event Out G (249)</p> <p>Ent.h Profile Event Out H (250)</p> <p>Fun Function Key (1001)</p> <p>LG Logic (239)</p> <p>Lnr Linearization (238)</p> <p>MAE Math (240)</p> <p>Pu Process Value (241)</p> <p>Sof.1 Special Function Output 1 (1532)</p> <p>Sof.2 Special Function Output 2 (1533)</p> <p>Sof.3 Special Function Output 3 (1534)</p> <p>Sof.4 Special Function Output 4 (1535)</p> <p>Tr Timer (244)</p> <p>vAr Variable (245)</p>		368 [offset 30]	0x6A (106) 1 to (24) 5	83	6005	uint RWES
<p>Note: Some values will be rounded off to fit in the four-character display. Full values can be read with other interfaces.</p> <p>Note: If there is only one instance of a menu, no submenus will appear.</p> <p>** These parameters/prompts are available in these menus with firmware revisions 6.0 and above.</p>								R: Read W: Write E: EEPROM S: User Set

RME Module • Setup Page

Display	Parameter Name Description	Range	Default	Modbus Relative Address	CIP Class Instance Attribute hex (dec)	Profibus Index	Parameter ID	Data Type & Read/Write
<input type="checkbox"/> F_i [Fi]	<i>Digital Output (1 to 24)</i> Function Instance Set the instance of the function selected above.	1 to 24	1	370 [offset 30]	0x6A (106) 1 to (24) 6	84	6006	uint RWES
<input type="checkbox"/> SZ [SZ]	<i>Digital Output (1 to 24)</i> Source Zone Set the zone of the function selected above.	0 to 16	0	382 [offset 30]	0x6A (106) 1 to (24) 0xC (12)	----	6012	uint RWES
<input type="checkbox"/> oCt [o.Ct]	<i>Digital Output (1 to 24)</i> Control Set the output control type. This parameter is only used with PID control, but can be set anytime.	<input type="checkbox"/> FtB Fixed Time Base (34) <input type="checkbox"/> oTb Variable Time Base (103)	Fixed Time Base	362 [offset 30]	0x6A (106) 1 to (24) 2	85	6002	uint RWES
<input type="checkbox"/> o.tb [o.tb]	<i>Digital Output (1 to 24)</i> Time Base Set the time base for fixed-time-base control.	[0.1 for Fast and Bi-Directional outputs, 5.0 for Slow outputs] to 60		364 [offset 30]	0x6A (106) 1 to (24) 3	86	6003	float RWES
<input type="checkbox"/> o.Lo [o.Lo]	<i>Digital Output (1 to 24)</i> Low Power Scale The power output will never be less than the value specified and will represent the value at which output scaling begins.	0.0 to 100.0	0.0	376 [offset 30]	0x6A (106) 1 to (24) 9	87	6009	float RWES
<input type="checkbox"/> o.hi [o.hi]	<i>Digital Output (1 to 24)</i> High Power Scale The power output will never be greater than the value specified and will represent the value at which output scaling stops.	0.0 to 100.0	100.0	378 [offset 30]	0x6A (106) 1 to (24) 0xA (10)	88	6010	float RWES
<input type="checkbox"/> ACE <input type="checkbox"/> SEt Action Menu								
<input type="checkbox"/> F_n [Fn]	<i>Action (1 to 8)</i> Function Set the action that will be triggered by this function.	<input type="checkbox"/> none None (61) <input type="checkbox"/> USrr User Settings Restore (227) <input type="checkbox"/> ALP_n Alarm (6) <input type="checkbox"/> S_iL Silence Alarms (108) <input type="checkbox"/> RoF Control Loops Off and Alarms to Non-alarm State (220) <input type="checkbox"/> FRL Force Alarm to Occur (218)	None	1284 [offset 20]	0x6E (110) 1 to 8 3	138	10003	uint RWES
<input type="checkbox"/> F_i [Fi]	<i>Action (1 to 8)</i> Function Instance Set the instance of the function selected above.	0 to 24	0	1286 [offset 20]	0x6E (110) 1 to 8 4	139	10004	uint RWES
Note: Some values will be rounded off to fit in the four-character display. Full values can be read with other interfaces. Note: If there is only one instance of a menu, no submenus will appear. ** These parameters/prompts are available in these menus with firmware revisions 6.0 and above.								R: Read W: Write E: EEPROM S: User Set

RME Module • Setup Page

Display	Parameter Name Description	Range	Default	Modbus Relative Address	CIP Class Instance Attribute hex (dec)	Profibus Index	Parameter ID	Data Type & Read/Write
SFnA [SFn.A]	<i>Action (1 to 8)</i> Source Function A Set the event or function that will trigger the action.	none None (61) Alm Alarm (6) CPE Compare (230) ctr Counter (231) diO Digital I/O (1142) EntA Profile Event Out A (233) EntB Profile Event Out B (234) EntC Profile Event Out C (235) EntD Profile Event Out D (236) EntE Profile Event Out E (247) EntF Profile Event Out F (248) EntG Profile Event Out G (249) EntH Profile Event Out H (250) Fun Function Key (1001) Lim Limit (126) Log Logic (239) Tim Timer (244) Var Variable (245)	None	1290 [offset 20]	0x6E (110) 1 to 8 6	----	10006	uint RWES
SiA [Si.A]	<i>Action (1 to 8)</i> Source Instance A Set the instance of the function selected above.	1 to 24	1	1282 [offset 20]	0x6E (110) 1 to 8 2	----	10002	uint RWES
SZA [SZ.A]	<i>Action (1 to 8)</i> Source Zone A Set the zone of the function selected above.	0 to 16	0	1292 [offset 20]	0x6E (110) 1 to 8 7	----	10007	uint RWES
LEv [LEv]	<i>Action (1 to 8)</i> Active Level Set the action that will be considered a true state.	Low Low (53) High High (37)	High	1280 [offset 20]	0x6E (110) 1 to 8 1	137	10001	uint RWES
<p>Note: Some values will be rounded off to fit in the four-character display. Full values can be read with other interfaces.</p> <p>Note: If there is only one instance of a menu, no submenus will appear.</p> <p>** These parameters/prompts are available in these menus with firmware revisions 6.0 and above.</p>								R: Read W: Write E: EEPROM S: User Set

RME Module • Setup Page

Display	Parameter Name Description	Range	Default	Modbus Relative Address	CIP Class Instance Attribute hex (dec)	Profibus Index	Parameter ID	Data Type & Read/Write
<div style="border: 1px solid black; padding: 2px;"> OFF SET </div> <p>Output Menu</p>								
Fn [Fn]	Output Digital (1 to 4, 7 to 10, 13 to 16, 19 to 22) Function Select what function will drive this output.	OFF Off (62) Ri Analog Input (142) ALPN Alarm (6) CPr Cool Power, Control Loop (161) hPr Heat Power, Control Loop (160) CPE Compare (230) CEr Counter (231) dio Digital I/O (1142) EntA Profile Event Out A (233) EntB Profile Event Out B (234) EntC Profile Event Out C (235) EntD Profile Event Out D (236) EntE Profile Event Out E (247) EntF Profile Event Out F (248) EntG Profile Event Out G (249) EntH Profile Event Out H (250) FUN Function Key (1001) LGC Logic (239) Lnr Linearization (238) MATH Math (240) Pv Process Value (241) Sof.1 Special Function Output 1 (1532) Sof.2 Special Function Output 2 (1533) Sof.3 Special Function Output 3 (1534) Sof.4 Special Function Output 4 (1535) TTR Timer (244) uRr Variable (245)	----	368 [offset 30]	0x6A (106) 1 to (24) 5	----	6005	uint RWES
Fi [Fi]	Output Digital (1 to 4, 7 to 10, 13 to 16, 19 to 22) Function Instance Set the instance of the function selected above.	1 to 24	1	370 [offset 30]	0x6A (106) 1 to (24) 6	----	6006	uint RWES
<p>Note: Some values will be rounded off to fit in the four-character display. Full values can be read with other interfaces.</p> <p>Note: If there is only one instance of a menu, no submenus will appear.</p> <p>** These parameters/prompts are available in these menus with firmware revisions 6.0 and above.</p>								R: Read W: Write E: EEPROM S: User Set

RME Module • Setup Page

Display	Parameter Name Description	Range	Default	Modbus Relative Address	CIP Class Instance Attribute hex (dec)	Profibus Index	Parameter ID	Data Type & Read/Write
<input type="checkbox"/> 52 [SZ]	<i>Output Digital (1 to 4, 7 to 10, 13 to 16, 19 to 22)</i> Source Zone Set the instance of the function selected above.	0 to 16	0	382 [offset 30]	0x6A (106) 1 to (24) 0x0C (12)	----	6012	uint RWES
<input type="checkbox"/> o.Ct [o.Ct]	<i>Output Digital (1 to 4, 7 to 10, 13 to 16, 19 to 22)</i> Control Set the output control type. This parameter is only used with PID control, but can be set anytime.	<input type="checkbox"/> FEB Fixed Time Base (34) <input type="checkbox"/> VEB Variable Time Base (103)	Fixed Time Base	362 [offset 30]	0x6A (106) 1 to (24) 2	----	6002	uint RWES
<input type="checkbox"/> o.tb [o.tb]	<i>Output Digital (1 to 4, 7 to 10, 13 to 16, 19 to 22)</i> Time Base Set the time base for fixed-time-base control.	0.1 to 60.0 seconds (solid-state relay or switched dc) 5.0 to 60.0 seconds (mechanical relay or no-arc power control)		364 [offset 30]	0x6A (106) 1 to (24) 3	----	6003	float RWES
<input type="checkbox"/> o.Lo [o.Lo]	<i>Output Digital (1 to 4, 7 to 10, 13 to 16, 19 to 22)</i> Low Power Scale The power output will never be less than the value specified and will represent the value at which output scaling begins.	0.0 to 100.0%	0.0%	376 [offset 30]	0x6A (106) 1 to (24) 9	----	6009	float RWES
<input type="checkbox"/> o.hi [o.hi]	<i>Output Digital (1 to 4, 7 to 10, 13 to 16, 19 to 22)</i> High Power Scale The power output will never be greater than the value specified and will represent the value at which output scaling stops.	0.0 to 100.0%	100.0%	378 [offset 30]	0x6A (106) 1 to (24) 0x0A (10)	----	6010	float RWES
<input type="checkbox"/> o.ty [o.ty]	<i>Output Process (1 to 3, 7 to 9, 13 to 15, 19 to 21)</i> Type ** Select whether the process output will operate in volts or milliamps.	<input type="checkbox"/> volt Volts (104) <input type="checkbox"/> mA Milliamps (112)	Volts	6990 [offset 60]	0x76 (118) 1-3, 7-9, 13-15, 19-21 1	----	18001	uint RWES
<p>Note: Some values will be rounded off to fit in the four-character display. Full values can be read with other interfaces.</p> <p>Note: If there is only one instance of a menu, no submenus will appear.</p> <p>** These parameters/prompts are available in these menus with firmware revisions 6.0 and above.</p>								R: Read W: Write E: EEPROM S: User Set

RME Module • Setup Page

Display	Parameter Name Description	Range	Default	Modbus Relative Address	CIP Class Instance Attribute hex (dec)	Profibus Index	Parameter ID	Data Type & Read/Write
<input type="checkbox"/> Fn [Fn]	Output Process (1 to 3, 7 to 9, 13 to 15, 19 to 21) Function ** Set the type of function that will drive this output.	<input type="checkbox"/> oFF Off (62) <input type="checkbox"/> A Analog Input (142) <input type="checkbox"/> CUrr Current (22) <input type="checkbox"/> CP Cool Power, Control Loop (161) <input type="checkbox"/> hPr Heat Power, Control Loop (160) <input type="checkbox"/> PUr Power, Control Loop (73) <input type="checkbox"/> Lnr Linearization (238) <input type="checkbox"/> MATH Math (240) <input type="checkbox"/> PV Process Value (241) <input type="checkbox"/> SPC Set Point Closed, Control Loop (242) <input type="checkbox"/> SPO Set Point Open, Control Loop (243) <input type="checkbox"/> Sof.1 Special Function Output 1 (1532) <input type="checkbox"/> Sof.2 Special Function Output 2 (1533) <input type="checkbox"/> Sof.3 Special Function Output 3 (1534) <input type="checkbox"/> Sof.4 Special Function Output 4 (1535) <input type="checkbox"/> VAR Variable (245)	Off	6992 [offset 60]	0x76 (118) 1-3, 7-9, 13-15, 19-21 2	----	18002	uint RWES
<input type="checkbox"/> Fi [Fi]	Output Process (1 to 3, 7 to 9, 13 to 15, 19 to 21) Function Instance ** Set the instance of the function selected above.	1 to 16	1	6996 [offset 60]	0x76 (118) 1-3, 7-9, 13-15, 19-21 4	----	18004	uint RWES
<input type="checkbox"/> ZSA [ZS.A]	Output Process (1 to 3, 7 to 9, 13 to 15, 19 to 21) Source Zone A ** Set the zone of the function selected above.	0 to 16	0	----	0x76 (118) 1-3, 7-9, 13-15, 19-21 0x13 (19)	----	18019	uint RWES
<input type="checkbox"/> SLo [S.Lo]	Output Process (1 to 3, 7 to 9, 13 to 15, 19 to 21) Scale Low ** Use to set the minimum value of the process range in electrical units..	-100.0 to 100.0	0.00	7006 [offset 60]	0x76 (118) 1-3, 7-9, 13-15, 19-21 9	----	18009	float RWES
<input type="checkbox"/> SHi [S.hi]	Output Process (1 to 3, 7 to 9, 13 to 15, 19 to 21) Scale High ** Use maximum value of the process range in electrical units..	-100.0 to 100.0	10.00	7008 [offset 60]	0x76 (118) 1-3, 7-9, 13-15, 19-21 0xA (10)	----	18010	float RWES
Note: Some values will be rounded off to fit in the four-character display. Full values can be read with other interfaces. Note: If there is only one instance of a menu, no submenus will appear. ** These parameters/prompts are available in these menus with firmware revisions 6.0 and above.								R: Read W: Write E: EEPROM S: User Set

RME Module • Setup Page

Display	Parameter Name Description	Range	Default	Modbus Relative Address	CIP Class Instance Attribute hex (dec)	Profibus Index	Parameter ID	Data Type & Read/Write
[r.Lo] [r.Lo]	<i>Output Process (1 to 3, 7 to 9, 13 to 15, 19 to 21)</i> Range Low ** Use to set the minimum value in process units. This will correspond with the Scale Low value.	-1,999.000 to 9,999.000°F or units -1,128.000 to 5,537.000°C	0.0°F or units -18°C	7010 [offset 60]	0x76 (118) 1-3, 7-9, 13-15, 19-21 0xB (11)	----	18011	float RWES
[r.hi] [r.hi]	<i>Output Process (1 to 3, 7 to 9, 13 to 15, 19 to 21)</i> Range High ** Use to set the maximum value in process units. This will correspond with the Scale High value.	-1,999.000 to 9,999.000°F or units -1,128.000 to 5,537.000°C	9,999.0°F or units 5,537.0°C	7012 [offset 60]	0x76 (118) 1-3, 7-9, 13-15, 19-21 0xC (12)	----	18012	float RWES
[o.CA] [o.CA]	<i>Output Process (1 to 3, 7 to 9, 13 to 15, 19 to 21)</i> Calibration Offset ** Set an offset value for a process output.	-1,999.000 to 9,999.000°F or units -1,110.555 to 5,555.000°C	0.0°F or units 0.0°C	7002 [offset 60]	0x76 (118) 1-3, 7-9, 13-15, 19-21 7	----	18007	float RWES

ALP7
SET
Alarm Menu

[A.ty] [A.ty]	<i>Alarm (1 to 8)</i> Type Select whether the alarm trigger is a fixed value or will track the set point.	[OFF] Off (62) [PrAL] Process Alarm (76)	Off	1468 [offset 60]	0x6D (109) 1 to 8 0x0F (15)	2	9015	uint RWES
[SFn.A] [SFn.A]	<i>Alarm (1 to 8)</i> Source Select what will trigger this alarm.	[AI] Analog Input (142) [CUR] Current (22) [PUL] Power, Control Loop (73) [LOR] Linearization (238) [MATH] Math (240) [PV] Process Value (241) [VAR] Variable (245)		1472 [offset 60]	0x6D (109) 1 to 8 0x11 (17)	3	9017	uint RWES
[Si.A] [Si.A]	<i>Alarm (1 to 8)</i> Source Instance Set the instance of the function selected above.	1 or 24	1	1474 [offset 60]	0x6D (109) 1 to 8 0x12 (18)	4	9018	uint RWES
[SZ.A] [SZ.A]	<i>Alarm (1 to 8)</i> Source Zone Set the zone of the function selected above.	0 or 16	0	1488 [offset 60]	0x6D (109) 1 to 8 0x19 (25)	----	9025	uint RWES
[A.hy] [A.hy]	<i>Alarm (1 to 8)</i> Hysteresis Set the hysteresis for an alarm. This determines how far into the safe region the process value needs to move before the alarm can be cleared.	0.001 to 9,999.000°F or units 0.001 to 5,555.000°C	1.0°F or units 1.0°C	1444 [offset 60]	0x6D (109) 1 to 8 3	6	9003	float RWES

Note:
Some values will be rounded off to fit in the four-character display. Full values can be read with other interfaces.

Note:
If there is only one instance of a menu, no submenus will appear.

** These parameters/prompts are available in these menus with firmware revisions 6.0 and above.

R: Read
W: Write
E: EEPROM
S: User Set

RME Module • Setup Page

Display	Parameter Name Description	Range	Default	Modbus Relative Address	CIP Class Instance Attribute hex (dec)	Profibus Index	Parameter ID	Data Type & Read/Write
<input type="checkbox"/> RL9 [A.Lg]	<i>Alarm (1 to 8)</i> Logic Select what the output condition will be during the alarm state.	<input type="checkbox"/> RLC Close On Alarm (17) <input type="checkbox"/> RLo Open On Alarm (66)	Close On Alarm	1448 [offset 60]	0x6D (109) 1 to 8 5	7	9005	uint RWES
<input type="checkbox"/> RSd [A.Sd]	<i>Alarm (1 to 8)</i> Sides Select which side or sides will trigger this alarm.	<input type="checkbox"/> both Both (13) <input type="checkbox"/> h,gh High (37) <input type="checkbox"/> LowL Low (53)	Both	1446 [offset 60]	0x6D (109) 1 to 8 4	8	9004	uint RWES
<input type="checkbox"/> RLo [A.Lo]	<i>Alarm (1 to 8)</i> Low Set Point ** If Alarm Type (Setup Page, Alarm Menu) is set to: process - set the process value that will trigger a low alarm.	-1,999.000 to 9,999.000°F or units -1,128.000 to 5,537.000°C	32.0°F or units 0.0°C	1442 [offset 60]	0x6D (109) 1 to 8 2	0	9002	float RWES
<input type="checkbox"/> Rhi [A.hi]	<i>Alarm (1 to 8)</i> High Set Point ** If Alarm Type (Setup Page, Alarm Menu) is set to: process - set the process value that will trigger a high alarm.	-1,999.000 to 9,999.000°F or units -1,128.000 to 5,537.000°C	300.0°F or units 150.0°C	1440 [offset 60]	0x6D (109) 1 to 8 1	1	9001	float RWES
<input type="checkbox"/> RLR [A.LA]	<i>Alarm (1 to 8)</i> Latching Turn alarm latching on or off. A latched alarm has to be turned off by the user.	<input type="checkbox"/> nLRE Non-Latching (60) <input type="checkbox"/> LRE Latching (49)	Non-Latching	1452 [offset 60]	0x6D (109) 1 to 8 7	9	9007	uint RWES
<input type="checkbox"/> RbL [A.bL]	<i>Alarm (1 to 8)</i> Blocking Select when an alarm will be blocked. After startup and/or after the set point changes, the alarm will be blocked until the process value enters the normal range.	<input type="checkbox"/> oFF Off (62) <input type="checkbox"/> Stc Startup (88) <input type="checkbox"/> SEPE Set Point (85) <input type="checkbox"/> both Both (13)	Off	1454 [offset 60]	0x6D (109) 1 to 8 8	10	9008	uint RWES
<input type="checkbox"/> RSi [A.Si]	<i>Alarm (1 to 8)</i> Silencing Turn alarm silencing on to allow the user to disable this alarm.	<input type="checkbox"/> oFF Off (62) <input type="checkbox"/> on On (63)	Off	1450 [offset 60]	0x6D (109) 1 to 8 6	11	9006	uint RWES
<input type="checkbox"/> RdSP [A.dSP]	<i>Alarm (1 to 8)</i> Display Display an alarm message when an alarm is active.	<input type="checkbox"/> oFF Off (62) <input type="checkbox"/> on On (63)	On	1470 [offset 60]	0x6D (109) 1 to 8 0x10 (16)	12	9016	uint RWES
<p>Note: Some values will be rounded off to fit in the four-character display. Full values can be read with other interfaces.</p> <p>Note: If there is only one instance of a menu, no submenus will appear.</p> <p>** These parameters/prompts are available in these menus with firmware revisions 6.0 and above.</p>								R: Read W: Write E: EEPROM S: User Set

RME Module • Setup Page

Display	Parameter Name Description	Range	Default	Modbus Relative Address	CIP Class Instance Attribute hex (dec)	Profibus Index	Parameter ID	Data Type & Read/Write
<input type="checkbox"/> RdL [A.dL]	<i>Alarm (1 to 8)</i> Delay Set the span of time that the alarm will be delayed after the process value exceeds the alarm set point.	0 to 9,999 seconds	0	1480 [offset 60]	0x6D (109) 1 to 8 0x15 (21)	13	9021	uint RWES
<input type="checkbox"/> CLr [A.Clr]	<i>Alarm (1 to 8)</i> Alarm Clear Request ** Write to this register to clear an alarm	0	----	1490 [offset 60]	0x6D (109) 1 to 8 0xD (13)	14	9013	uint W
<input type="checkbox"/> Sir [A.Sir]	<i>Alarm (1 to 8)</i> Alarm Silence Request ** Write to this register to silence an alarm	0	----	1492 [offset 60]	0x6D (109) 1 to 8 0xE (14)	15	9014	uint W
<input type="checkbox"/> SE [A.St]	<i>Alarm (1 to 8)</i> Alarm State ** Current state of alarm	Startup (88) None (61) Blocked (12) Alarm low (8) Alarm high (7) Error (28)	----	1456 [offset 60]	0x6D (109) 1 to 8 9	----	9009	uint R

Lnr
 SEE
Linearization Menu

<input type="checkbox"/> Fn [Fn]	<i>Linearization (1 to 8)</i> Function Set how this function will linearize Source A.	<input type="checkbox"/> OFF Off (62) <input type="checkbox"/> intE Interpolated (1482) <input type="checkbox"/> SEPd Stepped (1483)	Off	5548 [offset 70]	0x86 (134) 1 to 8 5	155	34005	uint RWES
<input type="checkbox"/> SFnA [SFn.A]	<i>Linearization (1 to 8)</i> Source Function A Set the type of function that will be used for this source.	<input type="checkbox"/> nonE None (61) <input type="checkbox"/> A Analog Input (142) <input type="checkbox"/> Cur Current (22) <input type="checkbox"/> CP Cool Power, Control Loop (161) <input type="checkbox"/> hPr Heat Power, Control Loop (160) <input type="checkbox"/> Pwr Power, Control Loop (73) <input type="checkbox"/> Lnr Linearization (238) <input type="checkbox"/> MATH Math (240) <input type="checkbox"/> Pv Process Value (241) <input type="checkbox"/> SPC Set Point Closed, Control Loop (242) <input type="checkbox"/> SPO Set Point Open, Control Loop (243) <input type="checkbox"/> VAR Variable (245)	None	5540 [offset 70]	0x86 (134) 1 to 8 1	----	34001	uint RWES
<input type="checkbox"/> SiA [Si.A]	<i>Linearization (1 to 8)</i> Source Instance A Set the instance of the function selected above.	1 or 24	1	5542 [offset 70]	0x86 (134) 1 to 8 2	----	34002	uint RWES

Note:
Some values will be rounded off to fit in the four-character display. Full values can be read with other interfaces.

Note:
If there is only one instance of a menu, no submenus will appear.

** These parameters/prompts are available in these menus with firmware revisions 6.0 and above.

R: Read
W: Write
E: EEPROM
S: User Set

RME Module • Setup Page

Display	Parameter Name Description	Range	Default	Modbus Relative Address	CIP Class Instance Attribute hex (dec)	Profibus Index	Parameter ID	Data Type & Read/Write
[SZ.A] [SZ.A]	<i>Linearization (1 to 16)</i> Source Zone A Set the zone of the function selected above.	0 or 16	0	5544 [offset 70]	0x86 (134) 1 to 8 3	----	34003	uint RWES
[Unit] [Unit]	<i>Linearization (1 to 8)</i> Units Set the units of Source A.	[Src] Source (1539) [none] None (61) [TEMP] Absolute Temperature (1540) [rTEMP] Relative Temperature (1541) [Power] Power (73) [Proc] Process (75) [rh] Relative Humidity (1538)	Source	5596 [offset 70]	0x86 (134) 1 to 8 0x1D (29)	----	34029	uint RWES
[ip.1] [ip.1]	<i>Linearization (1 to 8)</i> Input Point 1 Set the value that will be mapped to output 1.	-1,999.000 to 9,999.000	0.0	5554 [offset 70]	0x86 (134) 1 to 8 8	157	34008	float RWES
[op.1] [op.1]	<i>Linearization (1 to 8)</i> Output Point 1 Set the value that will be mapped to input 1.	-1,999.000 to 9,999.000	0.0	5574 [offset 70]	0x86 (134) 1 to 8 0x12 (18)	158	34018	float RWES
[ip.2] [ip.2]	<i>Linearization (1 to 8)</i> Input Point 2 Set the value that will be mapped to output 2.	-1,999.000 to 9,999.000	1.0	5556 [offset 70]	0x86 (134) 1 to 8 9	159	34009	float RWES
[op.2] [op.2]	<i>Linearization (1 to 8)</i> Output Point 2 Set the value that will be mapped to input 2.	-1,999.000 to 9,999.000	1.0	5576 [offset 70]	0x86 (134) 1 to 8 0x13 (19)	160	34019	float RWES
[ip.3] [ip.3]	<i>Linearization (1 to 8)</i> Input Point 3 Set the value that will be mapped to output 3.	-1,999.000 to 9,999.000	2.0	5558 [offset 70]	0x86 (134) 1 to 8 0x0A (10)	161	34010	float RWES
[op.3] [op.3]	<i>Linearization (1 to 8)</i> Output Point 3 Set the value that will be mapped to input 3.	-1,999.000 to 9,999.000	2.0	5578 [offset 70]	0x86 (134) 1 to 8 0x14 (20)	162	34020	float RWES
[ip.4] [ip.4]	<i>Linearization (1 to 8)</i> Input Point 4 Set the value that will be mapped to output 4.	-1,999.000 to 9,999.000	3.0	5560 [offset 70]	0x86 (134) 1 to 8 0x0B (11)	163	34011	float RWES
[op.4] [op.4]	<i>Linearization (1 to 8)</i> Output Point 4 Set the value that will be mapped to input 4.	-1,999.000 to 9,999.000	3.0	5580 [offset 70]	0x86 (134) 1 to 8 0x15 (21)	164	34021	float RWES
[ip.5] [ip.5]	<i>Linearization (1 to 8)</i> Input Point 5 Set the value that will be mapped to output 5.	-1,999.000 to 9,999.000	4.0	5562 [offset 70]	0x86 (134) 1 to 8 0x0C (12)	165	34012	float RWES
Note: Some values will be rounded off to fit in the four-character display. Full values can be read with other interfaces. Note: If there is only one instance of a menu, no submenus will appear. ** These parameters/prompts are available in these menus with firmware revisions 6.0 and above.								R: Read W: Write E: EEPROM S: User Set

RME Module • Setup Page

Display	Parameter Name Description	Range	Default	Modbus Relative Address	CIP Class Instance Attribute hex (dec)	Profibus Index	Param- eter ID	Data Type & Read/ Write
<input type="checkbox"/> P.5 [op.5]	<i>Linearization (1 to 8)</i> Output Point 5 Set the value that will be mapped to input 5.	-1,999.000 to 9,999.000	4.0	5582 [offset 70]	0x86 (134) 1 to 8 0x16 (22)	166	34022	float RWES
<input type="checkbox"/> P.6 [ip.6]	<i>Linearization (1 to 8)</i> Input Point 6 Set the value that will be mapped to output 6.	-1,999.000 to 9,999.000	5.0	5564 [offset 70]	0x86 (134) 1 to 8 0x0D (13)	167	34013	float RWES
<input type="checkbox"/> P.6 [op.6]	<i>Linearization (1 to 8)</i> Output Point 6 Set the value that will be mapped to input 6.	-1,999.000 to 9,999.000	5.0	5584 [offset 70]	0x86 (134) 1 to 8 0x17 (23)	168	34023	float RWES
<input type="checkbox"/> P.7 [ip.7]	<i>Linearization (1 to 8)</i> Input Point 7 Set the value that will be mapped to output 7.	-1,999.000 to 9,999.000	6.0	5566 [offset 70]	0x86 (134) 1 to 8 0x0E (14)	169	34014	float RWES
<input type="checkbox"/> P.7 [op.7]	<i>Linearization (1 to 8)</i> Output Point 7 Set the value that will be mapped to input 7.	-1,999.000 to 9,999.000	6.0	5586 [offset 70]	0x86 (134) 1 to 8 0x18 (24)	170	34024	float RWES
<input type="checkbox"/> P.8 [ip.8]	<i>Linearization (1 to 8)</i> Input Point 8 Set the value that will be mapped to output 8.	-1,999.000 to 9,999.000	7.0	5568 [offset 70]	0x86 (134) 1 to 8 0x0F (15)	171	34015	float RWES
<input type="checkbox"/> P.8 [op.8]	<i>Linearization (1 to 8)</i> Output Point 8 Set the value that will be mapped to input 8.	-1,999.000 to 9,999.000	7.0	5588 [offset 70]	0x86 (134) 1 to 8 0x19 (25)	172	34025	float RWES
<input type="checkbox"/> P.9 [ip.9]	<i>Linearization (1 to 8)</i> Input Point 9 Set the value that will be mapped to output 9.	-1,999.000 to 9,999.000	8.0	5570 [offset 70]	0x86 (134) 1 to 8 0x10 (16)	173	34016	float RWES
<input type="checkbox"/> P.9 [op.9]	<i>Linearization (1 to 8)</i> Output Point 9 Set the value that will be mapped to input 9.	-1,999.000 to 9,999.000	8.0	5590 [offset 70]	0x86 (134) 1 to 8 0x1A (26)	174	34026	float RWES
<input type="checkbox"/> P.10 [ip.10]	<i>Linearization (1 to 8)</i> Input Point 10 Set the value that will be mapped to output 10.	-1,999.000 to 9,999.000	9.0	5572 [offset 70]	0x86 (134) 1 to 8 0x11 (17)	175	34017	float RWES
<input type="checkbox"/> P.10 [op.10]	<i>Linearization (1 to 8)</i> Output Point 10 Set the value that will be mapped to input 10.	-1,999.000 to 9,999.000	9.0	5592 [offset 70]	0x86 (134) 1 to 8 0x1B (27)	176	34027	float RWES
<p>Note: Some values will be rounded off to fit in the four-character display. Full values can be read with other interfaces.</p> <p>Note: If there is only one instance of a menu, no submenus will appear.</p> <p>** These parameters/prompts are available in these menus with firmware revisions 6.0 and above.</p>								<p>R: Read W: Write E: EEPROM S: User Set</p>

RME Module • Setup Page

Display	Parameter Name Description	Range	Default	Modbus Relative Address	CIP Class Instance Attribute hex (dec)	Profibus Index	Parameter ID	Data Type & Read/Write
<input type="checkbox"/> CPE <input type="checkbox"/> SEt Compare Menu								
<input type="checkbox"/> F_n [Fn]	Compare (1 to 8) Function Set operator that will be used to compare Source A to Source B.	<input type="checkbox"/> OFF Off (62) <input type="checkbox"/> GT Greater Than (1435) <input type="checkbox"/> LT Less Than (1436) <input type="checkbox"/> E Equal To (1437) <input type="checkbox"/> NE Not Equal To (1438) <input type="checkbox"/> GE Greater or Equal (1439) <input type="checkbox"/> LE Less or Equal (1440)	Off	3996 [offset 40]	0x80 (128) 1 to 8 9	229	28009	uint RWES
<input type="checkbox"/> toL [toL]	Compare (1 to 8) Tolerance If the difference between Source A and Source B is less than this value the two will appear to be equal.	0 to 9,999.000	0.1	4000 [offset 40]	0x80 (128) 1 to 8 0x0B (11)	230	28011	float RWES
<input type="checkbox"/> SFn.A [SFn.A]	Compare (1 to 8) Source Function A Set the type of function that will be used for this source.	<input type="checkbox"/> none None (61) <input type="checkbox"/> A_i Analog Input (142) <input type="checkbox"/> Curr Current (22) <input type="checkbox"/> CP_r Cool Power, Control Loop (161) <input type="checkbox"/> hP_r Heat Power, Control Loop (160) <input type="checkbox"/> PL_Ur Power, Control Loop (73) <input type="checkbox"/> L_{nr} Linearization (238) <input type="checkbox"/> MATH Math (240) <input type="checkbox"/> P_v Process Value (241) <input type="checkbox"/> SP_C Set Point Closed, Control Loop (242) <input type="checkbox"/> SP_O Set Point Open, Control Loop (243) <input type="checkbox"/> vAr Variable (245)	None	3980 [offset 40]	0x80 (128) 1 to 8 1	----	28001	uint RWES
<input type="checkbox"/> Si.A [Si.A]	Compare (1 to 8) Source Instance A Set the instance of the function selected above.	1 to 24	1	3984 [offset 40]	0x80 (128) 1 to 8 3	----	28003	uint RWES
<input type="checkbox"/> SZ.A [SZ.A]	Compare (1 to 8) Source Zone A Set the zone of the function selected above.	0 to 16	0	3988 [offset 40]	0x80 (128) 1 to 8 5	----	28005	uint RWES
Note: Some values will be rounded off to fit in the four-character display. Full values can be read with other interfaces. Note: If there is only one instance of a menu, no submenus will appear. ** These parameters/prompts are available in these menus with firmware revisions 6.0 and above.								R: Read W: Write E: EEPROM S: User Set

RME Module • Setup Page

Display	Parameter Name Description	Range	Default	Modbus Relative Address	CIP Class Instance Attribute hex (dec)	Profibus Index	Parameter ID	Data Type & Read/Write
SFn.b [SFn.b]	<i>Compare (1 to 8)</i> Source Function B Set the type of function that will be used for this source.	none None (61) A Analog Input (142) Cur Current (22) CP Cool Power, Control Loop (161) hPr Heat Power, Control Loop (160) Pwr Power, Control Loop (73) Lnr Linearization (238) MATH Math (240) Pv Process Value (241) SPC Set Point Closed, Control Loop (242) SPO Set Point Open, Control Loop (243) VAR Variable (245)	None	3982 [offset 40]	0x80 (128) 1 to 8 2	----	28002	uint RWES
Si.b [Si.b]	<i>Compare (1 to 8)</i> Source Instance B Set the instance of the function selected above.	1 to 24	1	3986 [offset 40]	0x80 (128) 1 to 8 4	----	28004	uint RWES
SZ.b [SZ.b]	<i>Compare (1 to 8)</i> Zone Source B Set the zone of the function selected above.	0 to 16	0	3990 [offset 40]	0x80 (128) 1 to 8 6	----	28006	uint RWES
Er.h [Er.h]	<i>Compare (1 to 8)</i> Error Handling Use Error Handling to select the output value and error output state of this function if it receives an error signal from one or more sources and it cannot determine the output value.	EG True Good (1476) EB True Bad (1477) FG False Good (1478) FB False Bad (1479)	False Bad	4002 [offset 40]	0x80 (128) 1 to 8 0x0C (12)	----	28012	uint RWES
Err SEt Timer Menu								
Fn [Fn]	<i>Timer (1 to 8)</i> Function Set how the timer will function.	OFF Off (62) onP On Pulse (1471) dEL Delay (1472) oS One Shot (1473) rEE Retentive (1474)	Off	4956 [offset 50]	0x83 (131) 1 to 8 9	223	31009	uint RWES
Note: Some values will be rounded off to fit in the four-character display. Full values can be read with other interfaces. Note: If there is only one instance of a menu, no submenus will appear. ** These parameters/prompts are available in these menus with firmware revisions 6.0 and above.								R: Read W: Write E: EEPROM S: User Set

RME Module • Setup Page

Display	Parameter Name Description	Range	Default	Modbus Relative Address	CIP Class Instance Attribute hex (dec)	Profibus Index	Parameter ID	Data Type & Read/ Write
SFn.A [SFn.A]	<i>Timer (1 to 8)</i> Source Function A Set the type of function that will be used for this source which is the timer run signal.	none None (62) ALPn Alarm (6) CPn Cool Power, Control Loop (161) CPE Compare (230) CTn Counter (231) dio Digital I/O (1142) Ent.A Profile Event Out A (233) Ent.B Profile Event Out B (234) Ent.C Profile Event Out C (235) Ent.D Profile Event Out D (236) Ent.E Profile Event Out E (247) Ent.F Profile Event Out F (248) Ent.G Profile Event Out G (249) Ent.H Profile Event Out H (250) Fun Function Key (1001) LG Logic (239) Sof.1 Special Function Output 1 (1532) Sof.2 Special Function Output 2 (1533) Sof.3 Special Function Output 3 (1534) Sof.4 Special Function Output 4 (1535) TPn Timer (244) VR Variable (245)	None	4940 [offset 50]	0x83 (131) 1 to 8 1	----	31001	uint RWES
Si.A [Si.A]	<i>Timer (1 to 8)</i> Source Instance A Set the instance of the function selected above.	1 to 24	1	4944 [offset 50]	0x83 (131) 1 to 8 3	----	31003	uint RWES
SZ.A [SZ.A]	<i>Timer (1 to 8)</i> Source Zone A Set the zone of the function selected above.	0 to 16	0	4948 [offset 50]	0x83 (131) 1 to 8 5	----	31005	uint RWES
SAS.A [SAS.A]	<i>Timer (1 to 8)</i> State Active Source A Set what state will be read as on.	high High (37) low Low (53)	High	4960 [offset 50]	0x83 (131) 1 to 8 0x0B (11)	----	31011	uint RWES
Note: Some values will be rounded off to fit in the four-character display. Full values can be read with other interfaces. Note: If there is only one instance of a menu, no submenus will appear. ** These parameters/prompts are available in these menus with firmware revisions 6.0 and above.								R: Read W: Write E: EEPROM S: User Set

RME Module • Setup Page

Display	Parameter Name Description	Range	Default	Modbus Relative Address	CIP Class Instance Attribute hex (dec)	Profibus Index	Parameter ID	Data Type & Read/Write
SFn.b [SFn.b]	Timer (1 to 8) Source Function B Set the type of function that will be used to reset a retentive timer which is the timer reset signal.	none None (62) AlAr Alarm (6) CP Cool Power, Control Loop (161) CPE Compare (230) CTr Counter (231) di Digital I/O (1142) EntA Profile Event Out A (233) EntB Profile Event Out B (234) EntC Profile Event Out C (235) EntD Profile Event Out D (236) EntE Profile Event Out E (247) EntF Profile Event Out F (248) EntG Profile Event Out G (249) EntH Profile Event Out H (250) Fun Function Key (1001) LG Logic (239) Sof.1 Special Function Output 1 (1532) Sof.2 Special Function Output 2 (1533) Sof.3 Special Function Output 3 (1534) Sof.4 Special Function Output 4 (1535) TrTr Timer (244) vAr Variable (245)	None	4942 [offset 50]	0x83 (131) 1 to 8 2	----	31002	uint RWES
Si.b [Si.b]	Timer (1 to 8) Source Instance B Set the instance of the function selected above.	1 to 24	1	4946 [offset 50]	0x83 (131) 1 to 8 4	----	31004	uint RWES
SZ.b [SZ.b]	Timer (1 to 8) Source Zone B Set the zone of the function selected above.	0 to 16	0	4950 [offset 50]	0x83 (131) 1 to 8 6	----	31006	uint RWES
SAS.b [SAS.b]	Timer (1 to 8) State Active Source B Set what state will be read as on.	hi High (37) low Low (53)	High	4962 [offset 50]	0x83 (131) 1 to 8 0x0C (12)	----	31012	uint RWES
ti [ti]	Timer (1 to 8) Time Set the time span that will be measured.	0 to 9,999.000	1.0	4964 [offset 50]	0x83 (131) 1 to 8 0x0D (13)	224	31013	float RWES
<p>Note: Some values will be rounded off to fit in the four-character display. Full values can be read with other interfaces.</p> <p>Note: If there is only one instance of a menu, no submenus will appear.</p> <p>** These parameters/prompts are available in these menus with firmware revisions 6.0 and above.</p>								R: Read W: Write E: EEPROM S: User Set

RME Module • Setup Page

Display	Parameter Name Description	Range	Default	Modbus Relative Address	CIP Class Instance Attribute hex (dec)	Profibus Index	Parameter ID	Data Type & Read/Write
<input type="checkbox"/> LEu [LEv]	<i>Timer (1 to 8)</i> Active Level Set which output state will indicate on.	<input type="checkbox"/> h,9h High (37) <input type="checkbox"/> LoLuJ Low (53)	High	4966 [offset 50]	0x83 (131) 1 to 8 0x0E (14)	----	31014	uint RWES
<input type="checkbox"/> LEr <input type="checkbox"/> SEt Counter Menu								
<input type="checkbox"/> Fu [dir]	<i>Counter (1 to 8)</i> Function Set whether the counter increments or decrements the count value. Decrementing 0 returns 9,999. Incrementing 9,999 returns 0.	<input type="checkbox"/> UP Up (1456) <input type="checkbox"/> dn Down (1457)	Up	4476 [offset 40]	0x82 (130) 1 to 4 9	----	30009	uint RWES
<input type="checkbox"/> SFnA [SFn.A]	<i>Counter (1 to 8)</i> Source Function A Set the type of function that will be used for this source which is the counter clock signal.	<input type="checkbox"/> nonE None (62) <input type="checkbox"/> ALPQ Alarm (6) <input type="checkbox"/> CPc Cool Power, Control Loop (161) <input type="checkbox"/> CPE Compare (230) <input type="checkbox"/> LEr Counter (231) <input type="checkbox"/> dIo Digital I/O (1142) <input type="checkbox"/> EntA Profile Event Out A (233) <input type="checkbox"/> EntB Profile Event Out B (234) <input type="checkbox"/> EntC Profile Event Out C (235) <input type="checkbox"/> EntD Profile Event Out D (236) <input type="checkbox"/> EntE Profile Event Out E (247) <input type="checkbox"/> EntF Profile Event Out F (248) <input type="checkbox"/> EntG Profile Event Out G (249) <input type="checkbox"/> EntH Profile Event Out H (250) <input type="checkbox"/> FUn Function Key (1001) <input type="checkbox"/> LGc Logic (239) <input type="checkbox"/> TPTr Timer (244) <input type="checkbox"/> uRr Variable (245)	None	4460 [offset 40]	0x82 (130) 1 to 4 1	----	30001	uint RWES
<input type="checkbox"/> SiA [Si.A]	<i>Counter (1 to 8)</i> Source Instance A Set the instance of the function selected above.	1 to 24	1	4464 [offset 40]	0x82 (130) 1 to 4 3	----	30003	uint RWES
<input type="checkbox"/> SZA [SZ.A]	<i>Counter (1 to 8)</i> Source Zone A Set the zone of the function selected above.	0 to 16	0	4468 [offset 40]	0x82 (130) 1 to 4 5	----	30005	uint RWES
Note: Some values will be rounded off to fit in the four-character display. Full values can be read with other interfaces. Note: If there is only one instance of a menu, no submenus will appear. ** These parameters/prompts are available in these menus with firmware revisions 6.0 and above.								R: Read W: Write E: EEPROM S: User Set

RME Module • Setup Page

Display	Parameter Name Description	Range	Default	Modbus Relative Address	CIP Class Instance Attribute hex (dec)	Profibus Index	Param- eter ID	Data Type & Read/ Write
SR5A [SAS.A]	<i>Counter (1 to 8)</i> State Active Source A Set what output state will indicate on.	both Both (130) h,9h High (37) LoLJ Low (53)	High	4480 [offset 40]	0x82 (130) 1 to 4 0xB (11)	----	30011	uint RWES
SFn.b [SFn.b]	<i>Counter (1 to 8)</i> Source Function B Set the type of function that will be used for this source which is the counter load signal.	none None (62) ALn Alarm (6) CPn Cool Power, Control Loop (161) CPE Compare (230) Ctn Counter (231) d.o Digital I/O (1142) EntA Profile Event Out A (233) EntB Profile Event Out B (234) EntC Profile Event Out C (235) EntD Profile Event Out D (236) EntE Profile Event Out E (247) EntF Profile Event Out F (248) EntG Profile Event Out G (249) EntH Profile Event Out H (250) Fun Function Key (1001) LGn Logic (239) Trn Timer (244) vRn Variable (245)	None	4462 [offset 40]	0x82 (130) 1 to 4 2	----	30002	uint RWES
S.b [St.b]	<i>Counter (1 to 8)</i> Source Instance B Set the instance of the function selected above.	1 to 24	1	4466 [offset 40]	0x82 (130) 1 to 4 4	----	30004	uint RWES
SZb [SZ.b]	<i>Counter (1 to 8)</i> Source Zone B Set the zone of the function selected above.	0 to 16	0	4470 [offset 40]	0x82 (130) 1 to 4 6	----	30006	uint RWES
SR5b [SAS.b]	<i>Counter (1 to 8)</i> State Active Source B Set what output state will indicate on.	h,9h High (37) LoLJ Low (53)	High	4482 [offset 40]	0x82 (130) 1 to 4 0x0C (12)	----	30012	uint RWES
LoAd [LoAd]	<i>Counter (1 to 8)</i> Load Value Set the counter's initial value.	0 to 9,999	0	4484 [offset 40]	0x82 (130) 1 to 4 0x0D (13)	215	30013	uint RWES
<p>Note: Some values will be rounded off to fit in the four-character display. Full values can be read with other interfaces.</p> <p>Note: If there is only one instance of a menu, no submenus will appear.</p> <p>** These parameters/prompts are available in these menus with firmware revisions 6.0 and above.</p>								<p>R: Read W: Write E: EEPROM S: User Set</p>

RME Module • Setup Page

Display	Parameter Name Description	Range	Default	Modbus Relative Address	CIP Class Instance Attribute hex (dec)	Profibus Index	Parameter ID	Data Type & Read/Write
Er9E [trgt]	Counter (1 to 8) Target Value Set the value that will turn the output value on.	0 to 9,999	9,999	4486 [offset 40]	0x82 (130) 1 to 4 0x0E (14)	216	30014	uint RWES
LRE [LAt]	Counter (1 to 8) Latching Output latched.	No (59) Yes (106)	No	4492 [offset 40]	0x82 (130) 1 to 8 0x11 (17)	218	30017	uint RWES
Logic Menu Logic Menu								
Fn [Fn]	Logic (1 to 8) Function Set the operator that will be used to compare the sources.	<input type="checkbox"/> oFF Off (62) <input type="checkbox"/> Rnd And (1426) <input type="checkbox"/> or Or (1442) <input type="checkbox"/> E Equal To (1437) <input type="checkbox"/> nRnd Nand (1427) <input type="checkbox"/> nor Nor (1443) <input type="checkbox"/> nE Not Equal To (1438) <input type="checkbox"/> LRE Latch (1444) <input type="checkbox"/> rSFF RS Flip-Flop (1693)	Off	3084 [offset 80]	0x7F (127) 1 to 8 0x21 (33)	235	27033	uint RWES
Note: Some values will be rounded off to fit in the four-character display. Full values can be read with other interfaces. Note: If there is only one instance of a menu, no submenus will appear. ** These parameters/prompts are available in these menus with firmware revisions 6.0 and above.								R: Read W: Write E: EEPROM S: User Set

RME Module • Setup Page

Display	Parameter Name Description	Range	Default	Modbus Relative Address	CIP Class Instance Attribute hex (dec)	Profibus Index	Parameter ID	Data Type & Read/Write
SFnA [SFn.A]	<i>Logic (1 to 8)</i> Source Function A Set the type of function that will be used for this source.	<input type="checkbox"/> None None (62) <input type="checkbox"/> Alrm Alarm (6) <input type="checkbox"/> Comp Compare (230) <input type="checkbox"/> Count Counter (231) <input type="checkbox"/> DIO Digital I/O (1142) <input type="checkbox"/> EntA Profile Event Out A (233) <input type="checkbox"/> EntB Profile Event Out B (234) <input type="checkbox"/> EntC Profile Event Out C (235) <input type="checkbox"/> EntD Profile Event Out D (236) <input type="checkbox"/> EntE Profile Event Out E (247) <input type="checkbox"/> EntF Profile Event Out F (248) <input type="checkbox"/> EntG Profile Event Out G (249) <input type="checkbox"/> EntH Profile Event Out H (250) <input type="checkbox"/> Func Function Key (1001) <input type="checkbox"/> Limit Limit (126) <input type="checkbox"/> Logic Logic (239) <input type="checkbox"/> Sof1 Special Function Output 1 (1532) <input type="checkbox"/> Sof2 Special Function Output 2 (1533) <input type="checkbox"/> Sof3 Special Function Output 3 (1534) <input type="checkbox"/> Sof4 Special Function Output 4 (1535) <input type="checkbox"/> Timer Timer (244) <input type="checkbox"/> Var Variable (245)	None	3020 [offset 80]	0x7F (127) 1 to 8 1	----	27001	uint RWES
SiA [Si.A]	<i>Logic (1 to 8)</i> Source Instance A Set the instance of the function selected above.	1 to 24	1	3036 [offset 80]	0x7F (127) 1 to 8 9	----	27009	uint RWES
SZA [SZ.A]	<i>Logic (1 to 8)</i> Source Zone A Set the zone of the function selected above.	0 to 16	0	3052 [offset 80]	0x7F (127) 1 to 8 0x11 (17)	----	27017	uint RWES
Note: Some values will be rounded off to fit in the four-character display. Full values can be read with other interfaces. Note: If there is only one instance of a menu, no submenus will appear. ** These parameters/prompts are available in these menus with firmware revisions 6.0 and above.								R: Read W: Write E: EEPROM S: User Set

RME Module • Setup Page

Display	Parameter Name Description	Range	Default	Modbus Relative Address	CIP Class Instance Attribute hex (dec)	Profibus Index	Parameter ID	Data Type & Read/Write
[SF.n.b] [SFn.b]	Logic (1 to 8) Source Function B Set the type of function that will be used for this source.	<input type="radio"/> None (62) <input type="radio"/> Alarm (6) <input type="radio"/> Compare (230) <input type="radio"/> Counter (231) <input type="radio"/> Digital I/O (1142) <input type="radio"/> Profile Event Out A (233) <input type="radio"/> Profile Event Out B (234) <input type="radio"/> Profile Event Out C (235) <input type="radio"/> Profile Event Out D (236) <input type="radio"/> Profile Event Out E (247) <input type="radio"/> Profile Event Out F (248) <input type="radio"/> Profile Event Out G (249) <input type="radio"/> Profile Event Out H (250) <input type="radio"/> Function Key (1001) <input type="radio"/> Limit (126) <input type="radio"/> Logic (239) <input type="radio"/> Special Function Output 1 (1532) <input type="radio"/> Special Function Output 2 (1533) <input type="radio"/> Special Function Output 3 (1534) <input type="radio"/> Special Function Output 4 (1535) <input type="radio"/> Timer (244) <input type="radio"/> Variable (245)	None	3022 [offset 80]	0x7F (127) 1 to 8 2	----	27002	uint RWES
[S.i.b] [Si.b]	Logic (1 to 8) Source Instance B Set the instance of the function selected above.	1 to 24	1	3038 [offset 80]	0x7F (127) 1 to 8 0x0A (10)	----	27010	uint RWES
[SZ.b] [SZ.b]	Logic (1 to 8) Source Zone B Set the zone of the function selected above.	0 to 16	0	3054 [offset 80]	0x7F (127) 1 to 8 0x12 (18)	----	27018	uint RWES
Note: Some values will be rounded off to fit in the four-character display. Full values can be read with other interfaces. Note: If there is only one instance of a menu, no submenus will appear. ** These parameters/prompts are available in these menus with firmware revisions 6.0 and above.								R: Read W: Write E: EEPROM S: User Set

RME Module • Setup Page

Display	Parameter Name Description	Range	Default	Modbus Relative Address	CIP Class Instance Attribute hex (dec)	Profibus Index	Parameter ID	Data Type & Read/Write
<input type="checkbox"/> SFn.C [SFn.C]	<i>Logic (1 to 8)</i> Source Function C Set the type of function that will be used for this source.	<input type="checkbox"/> None None (62) <input type="checkbox"/> Alrm Alarm (6) <input type="checkbox"/> Comp Compare (230) <input type="checkbox"/> Count Counter (231) <input type="checkbox"/> DIO Digital I/O (1142) <input type="checkbox"/> Ent.A Profile Event Out A (233) <input type="checkbox"/> Ent.B Profile Event Out B (234) <input type="checkbox"/> Ent.C Profile Event Out C (235) <input type="checkbox"/> Ent.D Profile Event Out D (236) <input type="checkbox"/> Ent.E Profile Event Out E (247) <input type="checkbox"/> Ent.F Profile Event Out F (248) <input type="checkbox"/> Ent.G Profile Event Out G (249) <input type="checkbox"/> Ent.H Profile Event Out H (250) <input type="checkbox"/> Func Function Key (1001) <input type="checkbox"/> Limit Limit (126) <input type="checkbox"/> Logic Logic (239) <input type="checkbox"/> Sof.1 Special Function Output 1 (1532) <input type="checkbox"/> Sof.2 Special Function Output 2 (1533) <input type="checkbox"/> Sof.3 Special Function Output 3 (1534) <input type="checkbox"/> Sof.4 Special Function Output 4 (1535) <input type="checkbox"/> Timer Timer (244) <input type="checkbox"/> Var Variable (245)	None	3024 [offset 80]	0x7F (127) 1 to 8 3	----	27003	uint RWES
<input type="checkbox"/> Si.C [Si.C]	<i>Logic (1 to 8)</i> Source Instance C Set the instance of the function selected above.	1 to 24	1	3040 [offset 80]	v7F (127) 1 to 8 0x0B (11)	----	27011	uint RWES
<input type="checkbox"/> SZ.C [SZ.C]	<i>Logic (1 to 8)</i> Source Zone C Set the zone of the function selected above.	0 to 16	0	3056 [offset 80]	0x7F (127) 1 to 8 0x13 (19)	----	27019	uint RWES
<p>Note: Some values will be rounded off to fit in the four-character display. Full values can be read with other interfaces.</p> <p>Note: If there is only one instance of a menu, no submenus will appear.</p> <p>** These parameters/prompts are available in these menus with firmware revisions 6.0 and above.</p>								R: Read W: Write E: EEPROM S: User Set

RME Module • Setup Page

Display	Parameter Name Description	Range	Default	Modbus Relative Address	CIP Class Instance Attribute hex (dec)	Profibus Index	Parameter ID	Data Type & Read/Write
[SF.n.d] [SFn.d]	Logic (1 to 8) Source D Set the type of function that will be used for this source.	<input type="checkbox"/> none None (62) <input type="checkbox"/> ALP Alarm (6) <input type="checkbox"/> CPE Compare (230) <input type="checkbox"/> CTR Counter (231) <input type="checkbox"/> dio Digital I/O (1142) <input type="checkbox"/> ENtA Profile Event Out A (233) <input type="checkbox"/> ENtB Profile Event Out B (234) <input type="checkbox"/> ENtC Profile Event Out C (235) <input type="checkbox"/> ENtD Profile Event Out D (236) <input type="checkbox"/> ENtE Profile Event Out E (247) <input type="checkbox"/> ENtF Profile Event Out F (248) <input type="checkbox"/> ENtG Profile Event Out G (249) <input type="checkbox"/> ENtH Profile Event Out H (250) <input type="checkbox"/> FUN Function Key (1001) <input type="checkbox"/> LPT Limit (126) <input type="checkbox"/> L9C Logic (239) <input type="checkbox"/> SOf1 Special Function Output 1 (1532) <input type="checkbox"/> SOf2 Special Function Output 2 (1533) <input type="checkbox"/> SOf3 Special Function Output 3 (1534) <input type="checkbox"/> SOf4 Special Function Output 4 (1535) <input type="checkbox"/> TPT Timer (244) <input type="checkbox"/> VAR Variable (245)	None	3026 [offset 80]	0x7F (127) 1 to 8 4	----	27004	uint RWES
[S.i.d] [Si.d]	Logic (1 to 8) Source Instance D Set the instance of the function selected above.	1 to 24	1	3042 [offset 80]	0x7F (127) 1 to 8 0x0C (12)	----	27012	uint RWES
[SZ.d] [SZ.d]	Logic (1 to 8) Source Zone D Set the zone of the function selected above.	0 to 16	0	3058 [offset 80]	0x7F (127) 1 to 8 0x14 (20)	----	27020	uint RWES
Note: Some values will be rounded off to fit in the four-character display. Full values can be read with other interfaces. Note: If there is only one instance of a menu, no submenus will appear. ** These parameters/prompts are available in these menus with firmware revisions 6.0 and above.								R: Read W: Write E: EEPROM S: User Set

RME Module • Setup Page

Display	Parameter Name Description	Range	Default	Modbus Relative Address	CIP Class Instance Attribute hex (dec)	Profibus Index	Parameter ID	Data Type & Read/Write
SFnE [SFn.E]	Logic (1 to 8) Source E Function Set the type of function that will be used for this source.	none None (62) ALn Alarm (6) CPE Compare (230) ctr Counter (231) dio Digital I/O (1142) EntA Profile Event Out A (233) EntB Profile Event Out B (234) EntC Profile Event Out C (235) EntD Profile Event Out D (236) EntE Profile Event Out E (247) EntF Profile Event Out F (248) EntG Profile Event Out G (249) EntH Profile Event Out H (250) Fun Function Key (1001) Ln Limit (126) LG Logic (239) Sof.1 Special Function Output 1 (1532) Sof.2 Special Function Output 2 (1533) Sof.3 Special Function Output 3 (1534) Sof.4 Special Function Output 4 (1535) Tr Timer (244) var Variable (245)	None	3028 [offset 80]	0x7F (127) 1 to 8 5	----	27005	uint RWES
SiE [Si.E]	Logic (1 to 8) Source Instance E Set the instance of the function selected above.	1 to 24	1	3044 [offset 80]	0x7F (127) 1 to 8 0x0D (13)	----	27013	uint RWES
SZE [SZ.E]	Logic (1 to 8) Source Zone E Set the zone of the function selected above.	0 to 16	0	3060 [offset 80]	0x7F (127) 1 to 8 0x15 (21)	----	27021	uint RWES
Note: Some values will be rounded off to fit in the four-character display. Full values can be read with other interfaces. Note: If there is only one instance of a menu, no submenus will appear. ** These parameters/prompts are available in these menus with firmware revisions 6.0 and above.								R: Read W: Write E: EEPROM S: User Set

RME Module • Setup Page

Display	Parameter Name Description	Range	Default	Modbus Relative Address	CIP Class Instance Attribute hex (dec)	Profibus Index	Parameter ID	Data Type & Read/Write
SFnF [SFn.F]	<i>Logic (1 to 8)</i> Source Function F Set the type of function that will be used for this source.	<input type="checkbox"/> none None (62) <input type="checkbox"/> ALPn Alarm (6) <input type="checkbox"/> CPE Compare (230) <input type="checkbox"/> CEr Counter (231) <input type="checkbox"/> dio Digital I/O (1142) <input type="checkbox"/> EntA Profile Event Out A (233) <input type="checkbox"/> EntB Profile Event Out B (234) <input type="checkbox"/> EntC Profile Event Out C (235) <input type="checkbox"/> EntD Profile Event Out D (236) <input type="checkbox"/> EntE Profile Event Out E (247) <input type="checkbox"/> EntF Profile Event Out F (248) <input type="checkbox"/> EntG Profile Event Out G (249) <input type="checkbox"/> EntH Profile Event Out H (250) <input type="checkbox"/> FUn Function Key (1001) <input type="checkbox"/> L,n Limit (126) <input type="checkbox"/> LG Logic (239) <input type="checkbox"/> Sof.1 Special Function Output 1 (1532) <input type="checkbox"/> Sof.2 Special Function Output 2 (1533) <input type="checkbox"/> Sof.3 Special Function Output 3 (1534) <input type="checkbox"/> Sof.4 Special Function Output 4 (1535) <input type="checkbox"/> TPn Timer (244) <input type="checkbox"/> vRr Variable (245)	None	3030 [offset 80]	0x7F (127) 1 to 8 6	----	27006	uint RWES
<input type="checkbox"/> SiF [Si.F]	<i>Logic (1 to 8)</i> Source Instance F Set the instance of the function selected above.	1 to 24	1	3046 [offset 80]	0x7F (127) 1 to 8 0x0E (14)	----	27014	uint RWES
<input type="checkbox"/> SZF [SZ.F]	<i>Logic (1 to 8)</i> Source Zone F Set the zone of the function selected above.	0 to 16	0	3062 [offset 80]	0x7F (127) 1 to 8 0x16 (22)	----	27022	uint RWES
Note: Some values will be rounded off to fit in the four-character display. Full values can be read with other interfaces. Note: If there is only one instance of a menu, no submenus will appear. ** These parameters/prompts are available in these menus with firmware revisions 6.0 and above.								R: Read W: Write E: EEPROM S: User Set

RME Module • Setup Page

Display	Parameter Name Description	Range	Default	Modbus Relative Address	CIP Class Instance Attribute hex (dec)	Profibus Index	Parameter ID	Data Type & Read/Write
5Fn.9 [SFn.g]	<i>Logic (1 to 8)</i> Source Function G Set the type of function that will be used for this source.	<input type="checkbox"/> None None (62) <input type="checkbox"/> Alrm Alarm (6) <input type="checkbox"/> Comp Compare (230) <input type="checkbox"/> Count Counter (231) <input type="checkbox"/> DIO Digital I/O (1142) <input type="checkbox"/> EntA Profile Event Out A (233) <input type="checkbox"/> EntB Profile Event Out B (234) <input type="checkbox"/> EntC Profile Event Out C (235) <input type="checkbox"/> EntD Profile Event Out D (236) <input type="checkbox"/> EntE Profile Event Out E (247) <input type="checkbox"/> EntF Profile Event Out F (248) <input type="checkbox"/> EntG Profile Event Out G (249) <input type="checkbox"/> EntH Profile Event Out H (250) <input type="checkbox"/> Func Function Key (1001) <input type="checkbox"/> Limit Limit (126) <input type="checkbox"/> Logic Logic (239) <input type="checkbox"/> Sof.1 Special Function Output 1 (1532) <input type="checkbox"/> Sof.2 Special Function Output 2 (1533) <input type="checkbox"/> Sof.3 Special Function Output 3 (1534) <input type="checkbox"/> Sof.4 Special Function Output 4 (1535) <input type="checkbox"/> Timer Timer (244) <input type="checkbox"/> Var Variable (245)	None	3032 [offset 80]	0x7F (127) 1 to 8 7	----	27007	uint RWES
5I.9 [Si.g]	<i>Logic (1 to 8)</i> Source Instance G Set the instance of the function selected above.	1 to 24	1	3048 [offset 80]	0x7F (127) 1 to 8 0x0F (15)	----	27015	uint RWES
5Z.9 [SZ.g]	<i>Logic (1 to 8)</i> Source Zone G Set the zone of the function selected above.	0 to 16	0	3064 [offset 80]	0x7F (127) 1 to 8 0x17 (23)	----	27023	uint RWES
Note: Some values will be rounded off to fit in the four-character display. Full values can be read with other interfaces. Note: If there is only one instance of a menu, no submenus will appear. ** These parameters/prompts are available in these menus with firmware revisions 6.0 and above.								R: Read W: Write E: EEPROM S: User Set

RME Module • Setup Page

Display	Parameter Name Description	Range	Default	Modbus Relative Address	CIP Class Instance Attribute hex (dec)	Profibus Index	Parameter ID	Data Type & Read/ Write
<input type="checkbox"/> SFn.h [SF.n.h]	<i>Logic (1 to 8)</i> Source Function H Set the type of function that will be used for this source.	<input type="checkbox"/> None None (62) <input type="checkbox"/> ALPn Alarm (6) <input type="checkbox"/> CPE Compare (230) <input type="checkbox"/> CTr Counter (231) <input type="checkbox"/> d.io Digital I/O (1142) <input type="checkbox"/> EntA Profile Event Out A (233) <input type="checkbox"/> EntB Profile Event Out B (234) <input type="checkbox"/> EntC Profile Event Out C (235) <input type="checkbox"/> EntD Profile Event Out D (236) <input type="checkbox"/> EntE Profile Event Out E (247) <input type="checkbox"/> EntF Profile Event Out F (248) <input type="checkbox"/> EntG Profile Event Out G (249) <input type="checkbox"/> EntH Profile Event Out H (250) <input type="checkbox"/> FUn Function Key (1001) <input type="checkbox"/> L.Pn Limit (126) <input type="checkbox"/> LG Logic (239) <input type="checkbox"/> SoF.1 Special Function Output 1 (1532) <input type="checkbox"/> SoF.2 Special Function Output 2 (1533) <input type="checkbox"/> SoF.3 Special Function Output 3 (1534) <input type="checkbox"/> SoF.4 Special Function Output 4 (1535) <input type="checkbox"/> EPn Timer (244) <input type="checkbox"/> vRr Variable (245)	None	3034 [offset 80]	0x7F (127) 1 to 8 8	----	27008	uint RWES
<input type="checkbox"/> Si.h [Si.h]	<i>Logic (1 to 8)</i> Source Instance H Set the instance of the function selected above.	1 to 24	1	3050 [offset 80]	0x7F (127) 1 to 8 0x10 (16)	----	27016	uint RWES
<input type="checkbox"/> SZ.h [SZ.h]	<i>Logic (1 to 8)</i> Source Zone H Set the zone of the function selected above.	0 to 16	0	3066 [offset 80]	0x7F (127) 1 to 8 0x18 (24)	----	27024	uint RWES
<input type="checkbox"/> Er.h [Er.h]	<i>Logic (1 to 8)</i> Error Handling Use to select the output value and error output state of this function if it receives an error signal from one or more sources and it cannot determine the output value.	<input type="checkbox"/> Eg True Good (1476) <input type="checkbox"/> Eb True Bad (1477) <input type="checkbox"/> Fg False Good (1478) <input type="checkbox"/> Fb False Bad (1479)	False Bad	3088 [offset 80]	0x7F (127) 1 to 8 0x23 (35)	----	27035	uint RWES
<p>Note: Some values will be rounded off to fit in the four-character display. Full values can be read with other interfaces.</p> <p>Note: If there is only one instance of a menu, no submenus will appear.</p> <p>** These parameters/prompts are available in these menus with firmware revisions 6.0 and above.</p>								R: Read W: Write E: EEPROM S: User Set

RME Module • Setup Page

Display	Parameter Name Description	Range	Default	Modbus Relative Address	CIP Class Instance Attribute hex (dec)	Profibus Index	Parameter ID	Data Type & Read/Write	
Math Menu <input type="checkbox"/> Fn [Fn]									
	Math (1 to 8) Function Set the operator that will be applied to the sources.	<input type="checkbox"/> OFF Off (62) <input type="checkbox"/> Avg Average (1367) <input type="checkbox"/> PSC Process Scale (1371) <input type="checkbox"/> dSC Deviation Scale (1372) <input type="checkbox"/> dIFF Differential (1373) <input type="checkbox"/> rATE Ratio (1374) <input type="checkbox"/> Add Add (1375) <input type="checkbox"/> MMUL Multiply (1376) <input type="checkbox"/> AdIF Absolute Difference (1377) <input type="checkbox"/> Min Minimum (1378) <input type="checkbox"/> MAX Maximum (1379) <input type="checkbox"/> root Square Root (1380) <input type="checkbox"/> hold Sample and Hold (1381) <input type="checkbox"/> ALT Altitude (1649) <input type="checkbox"/> dELU Dewpoint (1650)	Off	2220 [offset 70]	0x7D (125) 1 0x15 (21)	128	25021	uint RWES	
	<input type="checkbox"/> SFnA [SFn.A]	Math (1 to 8) Source Function A Set the type of function that will be used for this source.	<input type="checkbox"/> none None (61) <input type="checkbox"/> AI Analog Input (142) <input type="checkbox"/> Curr Current (22) <input type="checkbox"/> CP Cool Power, Control Loop (161) <input type="checkbox"/> hPr Heat Power, Control Loop (160) <input type="checkbox"/> PLC Power, Control Loop (73) <input type="checkbox"/> Lnr Linearization (238) <input type="checkbox"/> FnATE Math (240) <input type="checkbox"/> PV Process Value (241) <input type="checkbox"/> SPC Set Point Closed, Control Loop (242) <input type="checkbox"/> SPo Set Point Open, Control Loop (243) <input type="checkbox"/> VAR Variable (245)		2180 [offset 70]	0x7D (125) 1 to 8 1	----	25001	uint RWES
	<input type="checkbox"/> SiA [Si.A]	Math (1 to 8) Source Instance A Set the instance of the function selected above.	1 to 24	1	2190 [offset 70]	0x7D (125) 1 to 8 6	----	25006	uint RWES
	<input type="checkbox"/> SZA [SZ.A]	Math (1 to 8) Source Zone A Set the zone of the function selected above.	0 to 16	0	2200 [offset 70]	0x7D (125) 1 to 8 0x0B (11)	----	25011	uint RWES
Note: Some values will be rounded off to fit in the four-character display. Full values can be read with other interfaces. Note: If there is only one instance of a menu, no submenus will appear. ** These parameters/prompts are available in these menus with firmware revisions 6.0 and above.								R: Read W: Write E: EEPROM S: User Set	

RME Module • Setup Page

Display	Parameter Name Description	Range	Default	Modbus Relative Address	CIP Class Instance Attribute hex (dec)	Profibus Index	Parameter ID	Data Type & Read/Write
SFn.b [SFn.b]	<i>Math (1 to 8)</i> Source Function B Set the type of function that will be used for this source.	none None (61) A Analog Input (142) Cur Current (22) CP Cool Power, Control Loop (161) hP Heat Power, Control Loop (160) Pwr Power, Control Loop (73) Lnc Linearization (238) MATH Math (240) Pv Process Value (241) SPC Set Point Closed, Control Loop (242) SPO Set Point Open, Control Loop (243) VAR Variable (245)	None	2182 [offset 70]	0x7D (125) 1 to 8 2	----	25002	uint RWES
Si.b [Si.b]	<i>Math (1 to 8)</i> Source Instance B Set the instance of the function selected above.	1 to 24	1	2192 [offset 70]	0x7D (125) 1 to 8 7	----	25007	uint RWES
SZ.b [SZ.b]	<i>Math (1 to 8)</i> Source Zone B Set the zone of the function selected above.	0 to 16	0	2202 [offset 70]	0x7D (125) 1 to 8 0x0C (12)	----	25012	uint RWES
SFn.C [SFn.C]	<i>Math (1 to 8)</i> Source Function C Set the type of function that will be used for this source.	none None (61) A Analog Input (142) Cur Current (22) CP Cool Power, Control Loop (161) hP Heat Power, Control Loop (160) Pwr Power, Control Loop (73) Lnc Linearization (238) MATH Math (240) Pv Process Value (241) SPC Set Point Closed, Control Loop (242) SPO Set Point Open, Control Loop (243) VAR Variable (245)	None	2184 [offset 70]	0x7D (125) 1 to 8 3	----	25003	uint RWES
Si.C [Si.C]	<i>Math (1 to 8)</i> Source Instance C Set the instance of the function selected above.	1 to 24	1	2194 [offset 70]	0x7D (125) 1 to 8 8	----	25008	uint RWES
SZ.C [SZ.C]	<i>Math (1 to 8)</i> Source Zone C Set the zone of the function selected above.	0 to 16	0	2204 [offset 70]	0x7D (125) 1 to 8 0x0D (13)	----	25013	uint RWES
<p>Note: Some values will be rounded off to fit in the four-character display. Full values can be read with other interfaces.</p> <p>Note: If there is only one instance of a menu, no submenus will appear.</p> <p>** These parameters/prompts are available in these menus with firmware revisions 6.0 and above.</p>								<p>R: Read W: Write E: EEPROM S: User Set</p>

RME Module • Setup Page

Display	Parameter Name Description	Range	Default	Modbus Relative Address	CIP Class Instance Attribute hex (dec)	Profibus Index	Parameter ID	Data Type & Read/Write
SFn.d [SFn.d]	<i>Math (1 to 8)</i> Source Function D Set the type of function that will be used for this source.	none None (61) A Analog Input (142) Curr Current (22) CP Cool Power, Control Loop (161) hPr Heat Power, Control Loop (160) Pwr Power, Control Loop (73) Lnr Linearization (238) MATH Math (240) Pv Process Value (241) SPC Set Point Closed, Control Loop (242) SPo Set Point Open, Control Loop (243) vAr Variable (245)		2186 [offset 70]	0x7D (125) 1 to 8 4	----	25004	uint RWES
SId [iS.d]	<i>Math (1 to 8)</i> Source Instance D Set the instance of the function selected above.	1 to 24	1	2196 [offset 70]	0x7D (125) 1 to 8 9	----	25009	uint RWES
SZd [SZ.d]	<i>Math (1 to 8)</i> Source Zone D Set the zone of the function selected above.	0 to 16	0	2206 [offset 70]	0x7D (125) 1 to (16) 0x0E (14)	----	25014	uint RWES
SFn.E [Sr.E]	<i>Math (1 to 8)</i> Source Function E Set the type of function that will be used for this source.	none None (62) ALP Alarm (6) CPE Compare (230) CTR Counter (231) dio Digital I/O (1142) EntA Profile Event Out A (233) EntB Profile Event Out B (234) EntC Profile Event Out C (235) EntD Profile Event Out D (236) EntE Profile Event Out E (247) EntF Profile Event Out F (248) EntG Profile Event Out G (249) EntH Profile Event Out H (250) FUn Function Key (1001) L9C Logic (239) TPR Timer (244) vAr Variable (245)	None	2188 [offset 70]	0x7D (125) 1 to 8 5	----	25005	uint RWES
Note: Some values will be rounded off to fit in the four-character display. Full values can be read with other interfaces. Note: If there is only one instance of a menu, no submenus will appear. ** These parameters/prompts are available in these menus with firmware revisions 6.0 and above.								R: Read W: Write E: EEPROM S: User Set

RME Module • Setup Page

Display	Parameter Name Description	Range	Default	Modbus Relative Address	CIP Class Instance Attribute hex (dec)	Profibus Index	Parameter ID	Data Type & Read/Write
<input type="checkbox"/> S_iE [Si.E]	<i>Math (1 to 8)</i> Source Instance E Set the instance of the function selected above.	1 to 24	1	2198 [offset 70]	0x7D (125) 1 to 8 0x0A (10)	----	25010	uint RWES
<input type="checkbox"/> S_ZE [SZ.E]	<i>Math (1 to 8)</i> Source Zone E Set the zone of the function selected above.	0 to 16	0	2208 [offset 70]	0x7D (125) 1 to 8 0x0F (15)	----	25015	uint RWES
<input type="checkbox"/> S_Lo [S.Lo]	<i>Math (1 to 8)</i> Scale Low If Math function is set to Process or Deviation Scale, this will scale Source A low value to Range Low setting.	-1,999.000 to 9,999.000	0.0	2226 [offset 70]	0x7D (125) 1 to 8 0x18 (24)	129	25024	float RWES
<input type="checkbox"/> S_Hi [S.hi]	<i>Math (1 to 8)</i> Scale High If Math function is set to Process or Deviation Scale, this will scale Source A high value to Range High setting.	-1,999.000 to 9,999.000	1.0	2228 [offset 70]	0x7D (125) 1 to 8 0x19 (25)	130	25025	float RWES
<input type="checkbox"/> Un_it [Unit]	<i>Math (1 to 8)</i> Units Set output units.	<input type="checkbox"/> S_rc Source (1539) <input type="checkbox"/> nonE None (61) <input type="checkbox"/> A_lP Absolute Temperature (1540) <input type="checkbox"/> r_lP Relative Temperature (1541) <input type="checkbox"/> P_lU_r Power (73) <input type="checkbox"/> P_ro Process (75) <input type="checkbox"/> r_h Relative Humidity (1538)	Source	2242 [offset 70]	0x7D (125) 1 to 8 0x20 (32)	----	25032	uint RWES
<input type="checkbox"/> r_Lo [r.Lo]	<i>Math (1 to 8)</i> Range Low If Math function is set to Process or Deviation Scale, this will output Source A Scale Low value to Range Low setting.	-1,999.000 to 9,999.000	0.0	2230 [offset 70]	0x7D (125) 1 to 8 0x1A (26)	131	25026	float RWES
<input type="checkbox"/> r_Hi [r.hi]	<i>Math (1 to 8)</i> Range High If Math function is set to Process or Deviation Scale, this will output Source A Scale High value to Range High setting.	-1,999.000 to 9,999.000	1.0	2232 [offset 70]	0x7D (125) 1 to 8 0x1B (27)	132	25027	float RWES
<input type="checkbox"/> P_un_t [P.un _t]	<i>Math (1 to 8)</i> Pressure Units If Math function is set for Pressure to Altitude units, set units of measure for conversion.	<input type="checkbox"/> P_Si Pressure Units (1671) <input type="checkbox"/> P_RS_c Pascal (1674) <input type="checkbox"/> A_lP_h Atmosphere (1675) <input type="checkbox"/> m_br mbar (1672) <input type="checkbox"/> T_or_r Torr (1673)	Pressure Units	2238 [offset 70]	0x7D (125) 1 to 8 0x1E (30)	----	25030	uint RWES
Note: Some values will be rounded off to fit in the four-character display. Full values can be read with other interfaces. Note: If there is only one instance of a menu, no submenus will appear. ** These parameters/prompts are available in these menus with firmware revisions 6.0 and above.								R: Read W: Write E: EEPROM S: User Set

RME Module • Setup Page

Display	Parameter Name Description	Range	Default	Modbus Relative Address	CIP Class Instance Attribute hex (dec)	Profibus Index	Parameter ID	Data Type & Read/Write
[Aunt] [A.unt]	Math (1 to 8) Altitude Units If Math function is set for Pressure to Altitude units, set units of measure for conversion.	<input type="checkbox"/> HFE Kilofeet (1671) <input type="checkbox"/> FE Feet (1674)	Kilofeet	2240 [offset 70]	0x7D (125) 1 to 8 0x1F (31)	----	25031	uint RWES
[FIL] [FIL]	Math (1 to 8) Filter Filtering smooths out the output signal of this function block. Increase the time to increase filtering.	0.0 to 60.0 seconds	0.0	2234 [offset 70]	0x7D (125) 1 to 8 0x1C (28)	----	25028	float RWES
<input type="checkbox"/> SoF <input type="checkbox"/> SEt Special Output Function Menu								
[Fn] [Fn]	Special Output (1 to 4) Function Set the function to match the device it will operate.	<input type="checkbox"/> oFF Off (62) <input type="checkbox"/> SEt Sequencer (1507) <input type="checkbox"/> uRL Motorized Valve (1508) <input type="checkbox"/> CoL Compressor Control (1506)	Off	6636 [offset 80]	0x87 (135) 1 to 4 9	181	35009	uint RWES
[SFnA] [SFn.A]	Special Output (1 to 4) Source Function A Set the type of function that will be used for this source.	<input type="checkbox"/> nonE None (61) <input type="checkbox"/> A Analog Input (142) <input type="checkbox"/> CP Cool Power, Control Loop (161) <input type="checkbox"/> hPr Heat Power, Control Loop (160) <input type="checkbox"/> PLU Power, Control Loop (73) <input type="checkbox"/> Lnr Linearization (238) <input type="checkbox"/> MAE Math (240) <input type="checkbox"/> Pu Process Value (241) <input type="checkbox"/> SoF.1 Special Function Output 1 (1532) <input type="checkbox"/> uRr Variable (245)	None	6620 [offset 80]	0x87 (135) 1 to 4 1	182	35001	uint RWES
[Si.A] [Si.A]	Special Output (1 to 4) Source Instance A Set the instance of the function selected above.	1 to 24	1	6624 [offset 80]	0x87 (135) 1 to 4 3	183	35003	uint RWES
[SZ.A] [SZ.A]	Special Output (1 to 4) Source Zone A Set the zone of the function selected above.	0 to 16	0	6628 [offset 80]	0x87 (135) 1 to 4 5	----	35005	uint RWES
Note: Some values will be rounded off to fit in the four-character display. Full values can be read with other interfaces. Note: If there is only one instance of a menu, no submenus will appear. ** These parameters/prompts are available in these menus with firmware revisions 6.0 and above.								R: Read W: Write E: EEPROM S: User Set

RME Module • Setup Page

Display	Parameter Name Description	Range	Default	Modbus Relative Address	CIP Class Instance Attribute hex (dec)	Profibus Index	Parameter ID	Data Type & Read/Write
SFn.b [SFn.B]	<i>Special Output (1 to 4)</i> Source Function B Set the type of function that will be used for this source.	none None (61) CPr Cool Power, Control Loop (161) hPr Heat Power, Control Loop (160) PLCr Power, Control Loop (73) Lnc Linearization (238) MAE Math (240) VR Variable (245)	None	6622 [offset 80]	0x87 (135) 1 to 4 2	184	35002	uint RWES
Si.b [Si.B]	<i>Special Output (1 to 4)</i> Source Instance B Set the instance of the function selected above.	1 to 24	1	6626 [offset 80]	0x87 (135) 1 to 4 4	185	35004	uint RWES
SZ.b [SZ.B]	<i>Special Output (1 to 4)</i> Source Zone B Set the zone of the function selected above.	0 to 16	0	6630 [offset 80]	0x87 (135) 1 to 4 6	- - - -	35006	uint RWES
Pon.A [Pon.A]	<i>Special Output (1 to 4)</i> Power On Level 1 If Function is set to Compressor Control: Use Source A for a first loop to inform the function whether the compressor will soon be required. • Set Power On Level 1 and Power Off Level 1 to the Source A values that will switch the compressor on and off.	-100.00 to 100.00%	0	6654 [offset 80]	0x87 (135) 1 to 4 0x12 (18)	186	35018	float RWES
PoF.A [PoF.A]	<i>Special Output (1 to 4)</i> Power Off Level 1	-100.00 to 100.00%	5	6656 [offset 80]	0x87 (135) 1 to 4 0x13 (19)	187	35019	float RWES
Pon.b [Pon.b]	<i>Special Output (1 to 4)</i> Power On Level 2 If Function is set to Compressor Control: Use Source B for a second loop to inform the function whether the compressor will soon be required. • Set Power On Level 2 and Power Off Level 2 to the Source B values that will switch the compressor on and off.	-100.00 to 100.00%	0	6658 [offset 80]	0x87 (135) 1 to 4 0x14 (20)	188	35020	float RWES
PoF.b [PoF.b]	<i>Special Output (1 to 4)</i> Power Off Level 2	-100.00 to 100.00%	5	6660 [offset 80]	0x87 (135) 1 to 4 0x15 (21)	189	35021	float RWES
<p>Note: Some values will be rounded off to fit in the four-character display. Full values can be read with other interfaces.</p> <p>Note: If there is only one instance of a menu, no submenus will appear.</p> <p>** These parameters/prompts are available in these menus with firmware revisions 6.0 and above.</p>								R: Read W: Write E: EEPROM S: User Set

RME Module • Setup Page

Display	Parameter Name Description	Range	Default	Modbus Relative Address	CIP Class Instance Attribute hex (dec)	Profibus Index	Parameter ID	Data Type & Read/Write
o.n.t [on.t]	<i>Special Output (1 to 4)</i> On Time If Function is set to Compressor Control: <ul style="list-style-type: none"> Set Minimum On Time and Minimum Off Time to the minimum span of time, in seconds, that the compressor will be on or off. 	0 to 9,999 seconds	20	6662 [offset 80]	0x87 (135) 1 to 4 0x16 (22)	190	35022	uint RWES
o.F.t [o.F.t]	<i>Special Output (1 to 4)</i> Off Time	0 to 9,999 seconds	20	6664 [offset 80]	0x87 (135) 1 to 4 0x17 (23)	191	35023	uint RWES
t.t [t.t]	<i>Special Output (1 to 8)</i> Valve Travel Time If Function is set to Motorized Valve: Source A will determine the valve position. <ul style="list-style-type: none"> Set this time in seconds representing the time that it will take the valve to travel between fully closed and fully open. 	10 to 9,999 seconds	120	6666 [offset 80]	0x87 (135) 1 to 4 0x18 (24)	192	35024	uint RWES
db [db]	<i>Special Output (1 to 4)</i> Dead Band If Function is set to Motorized Valve: <ul style="list-style-type: none"> Set to the minimum valve adjustment as a percentage, representing the movement of the valve in a single action. A small value improves accuracy and depletes valve life where a large value reduces the number of adjustments (less accurate)and the wear on the mechanism. 	1.0 to 100.0%	2	6668 [offset 80]	0x87 (135) 1 to 4 0x19 (25)	193	35025	float RWES
o.S1 [o.S1]	<i>Special Output (1 to 4)</i> Output 1 Size If Function is set to Sequencer: <ul style="list-style-type: none"> Set Output 1 Size, as a percentage of the total capacity of all output devices, or vernier output. This value must be larger than the values set for outputs 2 through 4. 	0 to 9,999	10	6674 [offset 80]	0x87 (135) 1 to 4 0x1C (28)	- - - -	35028	float RWES
<p>Note: Some values will be rounded off to fit in the four-character display. Full values can be read with other interfaces.</p> <p>Note: If there is only one instance of a menu, no submenus will appear.</p> <p>** These parameters/prompts are available in these menus with firmware revisions 6.0 and above.</p>								R: Read W: Write E: EEPROM S: User Set

RME Module • Setup Page

Display	Parameter Name Description	Range	Default	Modbus Relative Address	CIP Class Instance Attribute hex (dec)	Profibus Index	Parameter ID	Data Type & Read/ Write
<input type="checkbox"/> o.52 [o.S2]	<i>Special Output (1 to 8)</i> Output 2 Size If Function is set to Sequencer: <ul style="list-style-type: none"> Set the size of outputs 2 through 4 to represent a percentage of the total output capacity. Outputs 2 through 4 will control using the ON-OFF algorithm. 	0 to 9,999	0	6676 [offset 80]	0x87 (135) 1 to 4 0x1D (29)	----	35029	float RWES
<input type="checkbox"/> o.53 [o.S3]	<i>Special Output (1 to 8)</i> Output 3 Size If Function is set to Sequencer: <ul style="list-style-type: none"> Set the size of outputs 2 through 4 to represent a percentage of the total output capacity. Outputs 2 through 4 will control using the ON-OFF algorithm. 	0 to 9,999	0	6678 [offset 80]	0x87 (135) 1 to 4 0x1E (30)	----	35030	float RWES
<input type="checkbox"/> o.54 [o.S4]	<i>Special Output (1 to 8)</i> Output 4 Size If Function is set to Sequencer: <ul style="list-style-type: none"> Set the size of outputs 2 through 4 to represent a percentage of the total output capacity. Outputs 2 through 4 will control using the ON-OFF algorithm. 	0 to 9,999	0	6680 [offset 80]	0x87 (135) 1 to 4 0x1F (31)	----	35031	float RWES
<input type="checkbox"/> t.dL [t.dL]	<i>Special Output (1 to 8)</i> Time Delay If Function is set to Sequencer: <ul style="list-style-type: none"> Set in seconds to represent the minimum span of time that must elapse between the turn on of one (on-off) output to the next. 	0 to 9,999 seconds	0	6670 [offset 80]	0x87 (135) 1 to 4 0x1A (26)	----	35026	uint RWES
<input type="checkbox"/> o.t.o [ot.o]	<i>Special Output (1 to 8)</i> Output Order If Function is set to Sequencer: <ul style="list-style-type: none"> Set to Linear to turn the on-off outputs on in the same order every time. Select Progressive to rotate the order to balance usage and wear on contactors and heaters. 	<input type="checkbox"/> L in Linear (1509) <input type="checkbox"/> Pro Progressive (1510)	Linear	6672 [offset 80]	0x87 (135) 1 to 4 0x1B (27)	----	35027	uint RWES
Note: Some values will be rounded off to fit in the four-character display. Full values can be read with other interfaces. Note: If there is only one instance of a menu, no submenus will appear. ** These parameters/prompts are available in these menus with firmware revisions 6.0 and above.								R: Read W: Write E: EEPROM S: User Set

RME Module • Setup Page













Display	Parameter Name Description	Range	Default	Modbus Relative Address	CIP Class Instance Attribute hex (dec)	Profibus Index	Parameter ID	Data Type & Read/Write
<input type="checkbox"/> ARR <input type="checkbox"/> SET Variable Menu								
<input type="checkbox"/> EYPE [tyPE]	<i>Variable 1 to 8</i> Data Type Set the variable's data type.	<input type="checkbox"/> ANL9 Analog (1215) <input type="checkbox"/> d.9 Digital (1220)	Analog	6380 [offset 20]	0x66 (102) 1 to 8 1	210	2001	uint RWES
<input type="checkbox"/> Unit [Unit]	<i>Variable 1 to 8</i> Units Set the variable's units. Note: Units are always in degrees F when used for temperature	<input type="checkbox"/> none None (61) <input type="checkbox"/> rTP Relative Temperature (1541) <input type="checkbox"/> ATP Absolute Temperature (1540) <input type="checkbox"/> rh Relative Humidity (1538) <input type="checkbox"/> PLUr Power (73) <input type="checkbox"/> Pro Process (75)	Absolute Temperature	6392 [offset 20]	0x66 (102) 1 to 8 7	----	2007	uint RWES
<input type="checkbox"/> d.9 [Dig]	<i>Variable 1 to 8</i> Digital Set the variable's value.	<input type="checkbox"/> off Off (62) <input type="checkbox"/> on On (63)	Off	6382 [offset 20]	0x66 (102) 1 to 8 2	211	2002	uint RWES
<input type="checkbox"/> ANL9 [AnLg]	<i>Variable 1 to 8</i> Analog Set the variable's value.	-1,999.000 to 9,999.000	0.0	6384 [offset 20]	0x66 (102) 1 to 8 3	212	2003	float RWES
<input type="checkbox"/> GLBL <input type="checkbox"/> SET Global Menu								
<input type="checkbox"/> C.F [C_F]	<i>Global</i> Display Units Select which scale to use for temperature.	<input type="checkbox"/> F °F (30) <input type="checkbox"/> C °C (15)	°F	6948	0x67 (103) 1 5	110	3005	uint RWES
<input type="checkbox"/> ACLF [AC.LF]	<i>Global</i> AC Line Frequency Set the frequency to the applied ac line power source.	<input type="checkbox"/> 50 50 Hz (3) <input type="checkbox"/> 60 60 Hz (4)	60 Hz	366	0x66 (106) 1 4	----	6004	uint RWES
<input type="checkbox"/> dPrS [dPrS]	<i>Global</i> Display Pairs Defines the number of Display Pairs.	1 to 10	1	----	0x6A (103) 1 0x1C (28)	----	3028	uint RWES
<input type="checkbox"/> USrS [USr.S]	<i>Global</i> User Settings Save Save all of this controller's settings to the selected set that have a Data Type of RWES	<input type="checkbox"/> SEE1 User Set 1 (101) <input type="checkbox"/> SEE2 User Set 2 (102) <input type="checkbox"/> none None (61)	None	26	0x65 (101) 1 0x0E (14)	118	1014	uint RWE
<input type="checkbox"/> USrR [USr.r]	<i>Global</i> User Settings Restore Replace all of this controller's settings with another set.	<input type="checkbox"/> FCTY Factory (31) <input type="checkbox"/> none None (61) <input type="checkbox"/> SEE1 User Set 1 (101) <input type="checkbox"/> SEE2 User Set 2 (102)	None	24	0x65 (101) 1 0x0D (13)	117	1013	uint RWE
Note: Some values will be rounded off to fit in the four-character display. Full values can be read with other interfaces. Note: If there is only one instance of a menu, no submenus will appear. ** These parameters/prompts are available in these menus with firmware revisions 6.0 and above.								R: Read W: Write E: EEPROM S: User Set

5

Chapter 5: Factory Pages

Factory Page Parameters

To navigate to the Factory Page using the RUI, follow the steps below:

1. From the Home Page, press and hold both the Advance  and Infinity  keys for six seconds.
2. Press the Up  or Down  key to view available menus.
3. Press the Advance Key  to enter the menu of choice.
4. If a submenu exists (more than one instance), press the Up  or Down  key to select and then press the Advance Key  to enter.
5. Press the Up  or Down  key to move through available menu prompts.
6. Press the Infinity Key  to move backwards through the levels: parameter to submenu; submenu to menu; menu to Home Page.
7. Press and hold the Infinity Key  for two seconds to return to the Home Page.

On the following pages, top level menus are identified with a yellow background color.

Note:

Some of these menus and parameters may not appear, depending on the controller's options. See model number information in the Appendix for more information. If there is only one instance of a menu, no submenus will appear.

Note:

Some of the listed parameters may not be visible. Parameter visibility is dependent upon controller part number.

CUSE

FCEY Custom Setup Menu

i

CUSE Custom Setup (1 to 20)

PRP Parameter

iID Instance ID

LoC

FCEY Security Setting Menu

LoC Security Setting

LoLo Operations Page

PRSE Password Enable

rLoC Read Lock

SLoC Write Security

LoCL Locked Access Level

roLL Rolling Password

PRSw User Password

PRSR Administrator Password

ULoC

FCEY Security Setting Menu

LoC Security Setting

LoDE Public Key

PRSS Password

d, R9

FCEY Diagnostics Menu

d, R9 Diagnostics

Pn Part Number

rEw Software Revision

SbLd Software Build Number

Sn Serial Number

dRTE Date of Manufacture

Expansion Module • Factory Page

Display	Parameter Name Description	Range	Default	Modbus Relative Address	CIP Class Instance Attribute hex (dec)	Profibus Index	Parameter ID	Data Type & Read/Write
---------	----------------------------	-------	---------	-------------------------	--	----------------	--------------	------------------------

[USE]
[FCTY]

Custom Setup Menu

[PAR] [Par]	<p><i>Custom Menu</i> Parameter 1 to 20 If optional RUI is acquired select the parameters that will appear in the Home Page.</p> <p>The Parameter 1 value will appear in the upper display of the Home Page. It cannot be changed with the Up and Down Keys in the Home Page.</p> <p>The Parameter 2 value will appear in the lower display in the Home Page. It can be changed with the Up and Down Keys, if the parameter is a writable one.</p> <p>Scroll through the other Home Page parameters with the Advance Key  .</p>	<p>[none] None (61) [CF] Display Units (156) [USR] User Restore Set (227) [ALO] Alarm Low Set Point (42) [AHI] Alarm High Set Point (78) [AHS] Alarm Hysteresis (97) [USE] Custom (180)</p>	<p>1 = None 2 = Display Units 3 = Alarm Low Set Point 4 = Alarm High Set Point 5 to 20 = None</p>	----	----	----	14005	uint RWES
-----------------------	---	--	---	------	------	------	-------	-----------

[iid] [[iid]	<p><i>Custom Setup (1 to 20)</i> Instance ID Select the instance of the parameter selected above to be displayed.</p>	1 to 16		----	----	----	14003	int RWES
-------------------------	--	---------	--	------	------	------	-------	----------

[LoC]
[FCTY]

Security Setting Menu

[LoCo] [LoC.o]	<p><i>Security Setting</i> Operations Page Use to change the required security level clearance required to gain access to the Operations Page.</p>	1 to 3	2	6942	0x67 (103) 1 2	----	3002	unit RWE
[PASE] [LoC.P]	<p><i>Security Setting</i> Password Enable Turn Password Enable ON if a Password access feature is desired. This is in addition to Read Lock or Write Security.</p>	<p>[OFF] Off [ON] On</p>	Off	----	----	----	----	----

Note: Some values will be rounded off to fit in the four-character display. Full values can be read with another interface.
If there is only one instance of a menu, no submenus will appear.

R: Read
W: Write
E: EE-PROM
S: User Set

Expansion Module • Factory Page

Display	Parameter Name Description	Range	Default	Modbus Relative Address	CIP Class Instance Attribute hex (dec)	Profibus Index	Param- eter ID	Data Type & Read/ Write
rLoC [rLoC]	<i>Security Setting</i> Read Lock Set the read security clearance level. The user can access the selected level and all lower levels. Applies regardless of Password Enable setting. Set the Read Lock clearance level. The user can have read access to the selected level and all lower levels. If the Write Security level is higher than the Read Lock, the Read Lock level takes priority.	1 to 5	5	6958	0x67 (103) 1 0x0A (10)	----	3010	uint RWE
SLoC [SLoC]	<i>Security Setting</i> Write Security Set the write security clearance level. The user can access the selected level and all lower levels. Applies regardless of Password Enable setting. Set the Write Security clearance level. The user can have write access to the selected level and all lower levels. If the Write Security level is higher than the Read Lock, the Read Lock level takes priority.	0 to 5	5	6960	0x67 (103) 1 0x0B (11)	----	3011	uint RWE
LoCL [LoC.L]	<i>Security Setting</i> Locked Access Level Determines user level menu visibility when Password is enabled. See Features section under Password Security. This setting is in addition to Read Lock and Write Security. Consider using only Locked Access Level and Set Read Lock and Write Security to 5.	1 to 5	5	----	----	----	----	----
roLL [roLL]	<i>Security Setting</i> Rolling Password Applies if Password Enable is ON. When power is cycled a new Public Key will be displayed.	<input type="checkbox"/> oFF Off <input type="checkbox"/> oN On	Off	----	----	----	----	----
PAS.u [PAS.u]	<i>Security Setting</i> User Password Applies if Password Enable is ON. Used to acquire access to menus made available through the Locked Access Level setting. Do not forget the password as it is required to change Locked Access Level, Read Lock or Write Security.	10 to 999	63	----	----	----	----	----
<p>Note: Some values will be rounded off to fit in the four-character display. Full values can be read with another interface.</p> <p>If there is only one instance of a menu, no submenus will appear.</p>								R: Read W: Write E: EE- PROM S: User Set

Expansion Module • Factory Page

Display	Parameter Name Description	Range	Default	Modbus Relative Address	CIP Class Instance Attribute hex (dec)	Profibus Index	Param- eter ID	Data Type & Read/ Write
PAS.A [PAS.A]	<i>Security Setting</i> Administrator Password Applies if Password Enable is ON. Used to acquire access to menus made available through the Locked Access Level setting. Do not forget the password as it is required to change Locked Access Level, Read Lock, Write Security and the ability to change the Passwords.	10 to 999	156	----	----	----	----	----
ULoL FCEY Security Setting Menu								
Code [CodE]	<i>Security Setting</i> Public Key If Rolling Password turned on, generates a random number when power is cycled. If Rolling Password is off, fixed number will be displayed.	Customer Specific	0	----	----	----	----	----
PASS [PASS]	<i>Security Setting</i> Password Number returned from calculation found in Features section under Password Security.	-1999 to 9999	0	----	----	----	----	----
d.r9 FCEY Diagnostics Menu								
Pn [Pn]	<i>Diagnostics Menu</i> Part Number Display this controller's part number.	24	----	----	0x65 (101) 1 9	115	1009	int RWE
rEu [rEu]	<i>Diagnostics Menu</i> Software Revision Display this controller's firmware revision number.	5	----	4	0x65 (101) 1 to 5 0x11 (17)	116	1003	int R
S.bLd [S.bLd]	<i>Diagnostics Menu</i> Software Build Number Display the firmware build number.	0 to 2,147,483,647	----	8	0x65 (101) 1 to 5 5	----	1005	float R
Sn [Sn]	<i>Diagnostics Menu</i> Serial Number Display the serial number.	0 to 2,147,483,647	----	12	0x65 (101) 1 7	----	1007	float RWE
dAtE [dAtE]	<i>Diagnostics Menu</i> Date of Manufacture Display the date code.	0 to 2,147,483,647	----	14	0x65 (101) 1 8	----	1008	float RWE
No Display	<i>Diagnostics Menu</i> Hardware ID Read the hardware ID.	24 or 117	24	0	0x65 (101) 1 1	----	1001	signed 32-bit R
Note: Some values will be rounded off to fit in the four-character display. Full values can be read with another interface. If there is only one instance of a menu, no submenus will appear.								R: Read W: Write E: EE-PROM S: User Set

6

Chapter 6: Features

Saving and Restoring User Settings	80
Inputs	80
Outputs	80
Variable Time Base	80
Retransmitting a Process Value or Set Point	81
Compressor Control	81
Motorized Valve Control	81
Alarms	81
Process Alarms	82
Alarm Set Points	82
Alarm Hysteresis	82
Alarm Latching	82
Alarm Silencing	82
Alarm Blocking	83
Using Password Security	84
Software Configuration	86
Function Block Descriptions	89
Action Function	89
Alarm Function	89
Compare Function	90
Counter Function	92
Custom Function	92
Diagnostic Function	92
Digital Input/Output Function	93
Global Function	93
Linearization Function	93
Logic Function	94
Math Function	97
Output Function	102
Security Function	103
Special Output Function	103
Timer Function	104
Variable Function	109

Saving and Restoring User Settings

Recording setup and operations parameter settings for future reference is very important. If you unintentionally change these, you will need to program the correct settings back into the controller to return the equipment to operational condition.

After you program the controller and verify proper operation, use User Settings Save **[USR.S]** (Setup Page, Global Menu) to save the settings into either of two files in the controller and you want to return the controller to the saved values, use User Settings Restore **[USR.R]** (Setup Page, Global Menu) to recall one of the saved settings.

A digital input or the Function Key can also be configured to restore parameters.

CAUTION:

If a Digital Input or Function Key is programmed for User Setting Restore, the operator may select Factory Restore and the Digital Input or Function Key may no longer be programmed for User Setting Restore.

Note:

Only perform the above procedure when you are sure that all the correct settings are programmed into the controller. Saving the settings overwrites any previously saved collection of settings. Be sure to document all the controller settings.

Inputs

Ten Point Linearization

The linearization function allows a user to re-linearize a value read from an analog source. The function selections are Off, Interpolated and Stepped. When set to Off the output will match the Source A value plus offset. There are 10 data points used to compensate for differences between the source value read (input point) and the desired value (output point). Multiple data points enable compensation for non-linear differences between the sensor readings and target process values over the thermal or process system operating range. Sensor reading differences can be caused by sensor placement, tolerances, an inaccurate sensor or lead resistance.

The user specifies the unit of measurement and then each data point by entering an input point value and a corresponding output point value. Each data point must be incrementally higher than the previous point. The linearization function will interpolate data points linearly in between specified data points.

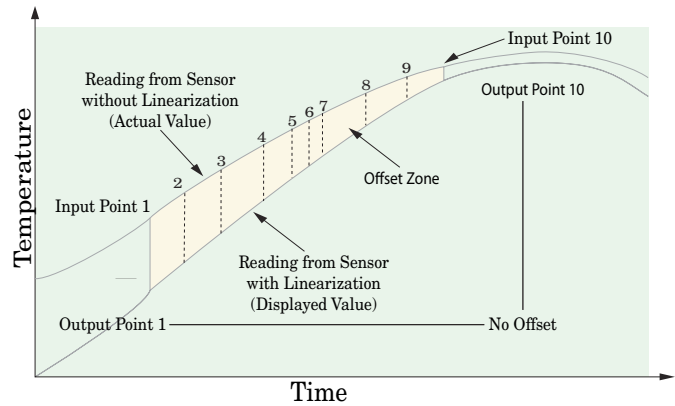

Outputs

Variable Time Base

Variable time base is the preferred method for controlling a resistive load, providing a very short time base for longer heater life. Unlike phase-angle firing, variable-time-base switching does not limit the current and voltage applied to the heater.

With variable time base outputs, the PID algorithm calculates an output between 0 and 100%, but the output is distributed in groupings of three ac line cycles. For each group of three ac line cycles, the controller decides whether the power should be on or off. There is no fixed cycle time since the decision is made for each group of cycles. When used in conjunction with a zero cross (burst fire) device, such as a solid-state power controller, switching is done only at the zero cross of the ac line, which helps reduce electrical noise (RFI).

Variable time base should be used with solid-state power controllers, such as a solid-state relay (SSR) or silicon controlled rectifier (SCR) power controller. Do not use a variable time base output for controlling electromechanical relays, mercury displacement relays, inductive loads or heaters with unusual resistance characteristics.

The combination of variable time base output and a solid-state relay can inexpensively approach the effect of analog, phase-angle fired control.

Select the AC Line Frequency **[ACLF]** (Setup Page, Global Menu), 50 or 60 Hz.

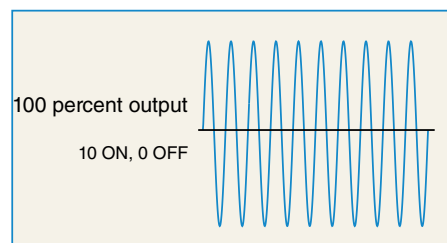

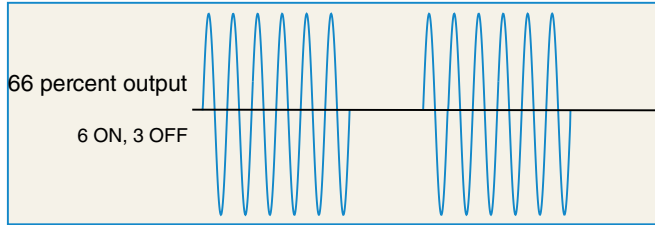
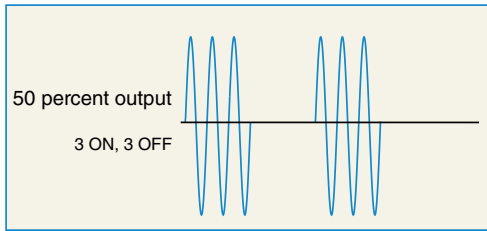

Retransmitting a Process Value or Set Point

The retransmit feature allows a process output to provide an analog signal that represents the set point or process value. The signal may serve as a remote set point for another controller or as an input for a chart recorder documenting system performance over time.

In choosing the type of retransmit signal the operator must take into account the input impedance of the device to be retransmitted to and the required signal type, either voltage or milliamperes.

Typically, applications might use the retransmit option to record one of the variables with a chart recorder or to generate a set point for other controls in a multi-zone application.

Outputs 1 to 3, 7 to 9, 13 to 15 and 19 to 21 can be ordered as process outputs. Assign an analog source to Output Function to accomplish retransmit of a process or set point value.

Note:

The active set point is not retransmitted, only the user requested closed loop set point which may not be the closed loop set point in control. Retransmitting a profiling closed loop set point is not allowed.

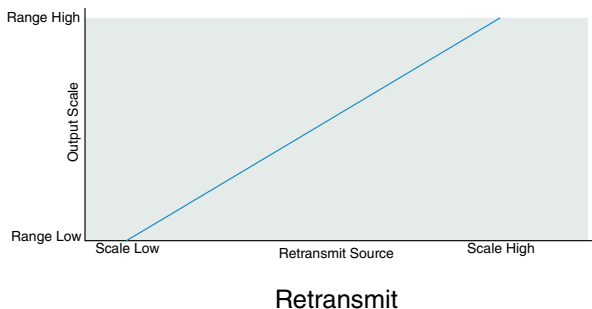

Compressor Control

The compressor control can save wear on a compressor and prevent it from locking up from short cycling. A bypass valve operated by a control output regulates how the process is cooled, while another output

switches the compressor on and off. The compressor will not turn on until the output power exceeds the Compressor On % Power for a time longer than the Compressor On Delay. The compressor will not turn off until the output power exceeds the Compressor Off % Power for a time longer than the Compressor Off Delay.

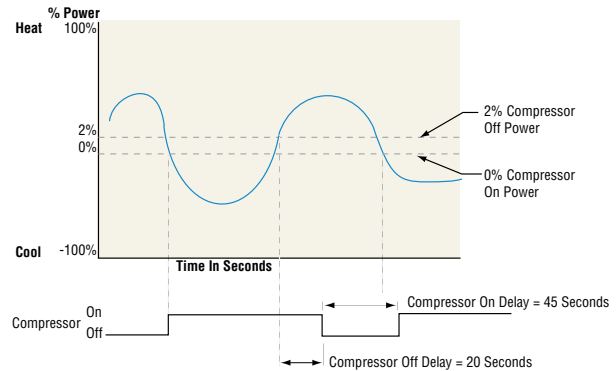

Motorized Valve Control

A motorized valve is used to regulate the flow of fluid which in turn impacts the loop process value. A valve is opened or closed by closing contacts to drive the valve in the intended direction. This feature is configured by selecting Motorized Valve as the function in the Setup Page, Special Output Function menu. Source Function A is selected for either Heat or Cool Power then entering the Valve Travel Time and Deadband.

Lastly, program the outputs which will open and close the valve. The algorithm will calculate Dead Time which is the minimum on time that the valve will travel once it is turned on in either the closed or open direction. $Dead\ Time = Valve\ Dead\ Band / 100 * Valve\ Travel\ Time$.

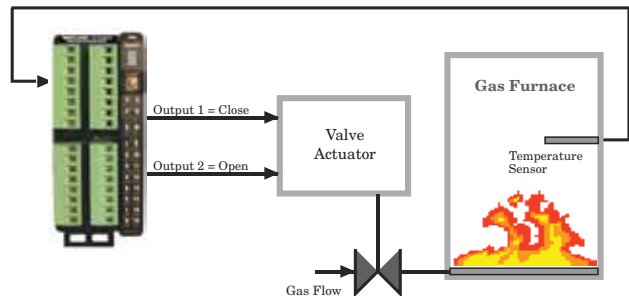

Alarms

Alarms are activated when the output level, process value or temperature leaves a defined range. A user can configure how and when an alarm is triggered, what action it takes and whether it turns off automatically when the alarm condition is over.

Configure alarm outputs in the Setup Page before setting alarm set points.

Alarms do not have to be assigned to an output. Alarms can be monitored and controlled through the front panel or by using software.

Process Alarms

A process alarm uses one or two absolute set points to define an alarm condition.

Select the alarm type **[ALY]** via the Setup Page, Alarm Menu.

Alarm Set Points

The alarm high set point defines the process value or temperature that will trigger a high side alarm. The alarm low set point defines the temperature that will trigger a low side alarm. For deviation alarms, a negative set point represents a value below closed loop set point. A positive set point represents a value above closed loop set point. View or change alarm set points with Alarm Low **[ALO]** and Alarm High Set Points **[AHL]** (Operations Page, Alarm Menu).

Alarm Hysteresis

An alarm state is triggered when the process value reaches the alarm high or alarm low set point. Alarm Hysteresis defines how far the process must return into the normal operating range before the alarm can be cleared.

Alarm Hysteresis is a zone inside each alarm set point. This zone is defined by adding the hysteresis value to the alarm low set point or subtracting the hysteresis value from the alarm high set point. View or change Alarm Hysteresis **[AHY]** via the Setup Page, Alarm Menu.

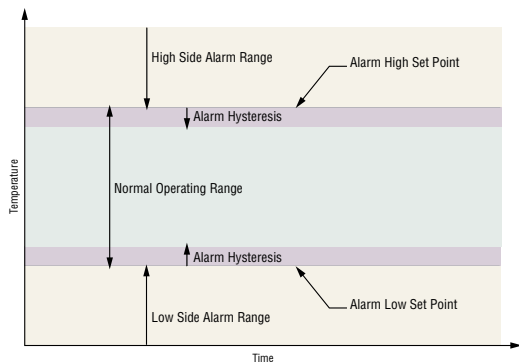

Alarm Set Points and Hysteresis

Alarm Latching

A latched alarm will remain active after the alarm condition has passed. It can only be deactivated by the user and only when the alarm condition no longer exists.

If using an RUI an active message, such as an alarm message, will cause the display to toggle between the normal settings and the active message in the upper display and **[ALLEN]** in the lower display. To clear a latched alarm:

1. Push the Advance Key **[A]** to display **[,9nr]** in the upper display and the message source in the lower display.
2. Use the Up **[↑]** or Down **[↓]** keys to scroll through

possible responses, such as Clear **[CLR]** or Silence **[SIL]**.

3. Push the Advance **[A]** or Infinity **[∞]** key to execute the action.

Without an RUI, a latched alarm can be reset by cycling power to the module or configuring an Action function within the control to perform a reset. Do this by setting the Action Function to alarm and trigger the Action to occur through Source Function A.

An alarm that is not latched (self-clearing) will deactivate automatically when the alarm condition has passed. Turn Alarm Latching **[ALLA]** on or off via the Setup Page, Alarm Menu.

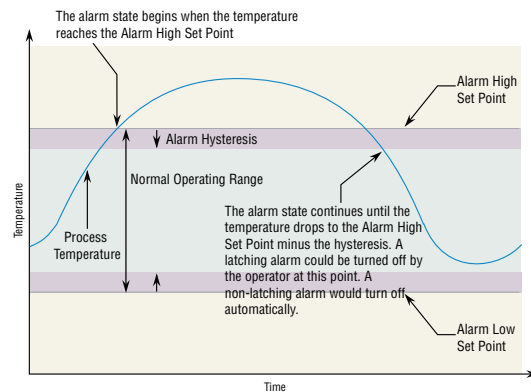

Alarm Response with Hysteresis

Alarm Silencing

If alarm silencing is on the operator can disable the alarm output while the controller is in an alarm state. The process value or temperature has to enter the normal operating range beyond the hysteresis zone to activate the alarm output function again.

If using an RUI an active message, such as an alarm message, will cause the display to toggle between the normal settings and the active message in the upper display and **[ALLEN]** in the lower display. To silence an alarm:

1. Push the Advance Key **[A]** to display **[,9nr]** in the upper display and the message source in the lower display.
2. Use the Up **[↑]** and Down **[↓]** keys to scroll through possible responses, such as Clear **[CLR]** or Silence **[SIL]**.
3. Push the Advance **[A]** or Infinity **[∞]** key to execute the action.

Without an RUI, silencing an alarm can be accomplished by configuring an Action function within the control to silence the alarm. Do this by setting the Action Function to Silence and trigger the Action to occur through Source Function A.

Turn Alarm Silencing **[AS]** on or off via the Setup Page, Alarm Menu.

Alarm Blocking

Alarm blocking allows a system to warm up after it has been started up. With alarm blocking on, an alarm is not triggered when the process temperature is initially lower than the alarm low set point or higher than the alarm high set point. The process temperature has to enter the normal operating range beyond the hysteresis zone to activate the alarm function.

If the RME module has an output that is functioning as a deviation alarm, the alarm is blocked when the set point is changed, until the process value re-enters the normal operating range.

Turn Alarm Blocking **ABL** on or off via the Setup Page, Alarm Menu.

Programming the EZ Key/s

If using an RUI the EZ Key can be configured either in the Setup Menu or with EZ-ZONE configurator software, using a personal computer.

The following examples show how to program the EZ Key to start and stop a profile.

- To go to the Setup Page from the Home Page, press both the Up and Down keys for six seconds. **A**, will appear in the upper display and **SET** will appear in the lower display.
- Press the Up Key until **Fun** appears in the upper display and **SET** will appear in the lower display.
- Press the Advance Key until Digital Input Level **LEu** appears in the lower display. Use an arrow key to specify the state of the key (high or low) when the controller is powered up. Functions will toggle with each press of the EZ Key, such as Profile Start/Stop.
- Press the Advance Key . The lower display will show Digital Function **Fn**. Press the Up or Down key to scroll through the functions that can be assigned to the EZ Key
When Profile Start/Stop **PSES** appears in the upper display and **Fn** appears in the lower display, press the Advance Key once to select that function and move to the Function Instance **F**, parameter.
- Press the Up or Down key to scroll to the profile that you want the EZ Key to control.
- The instance tells the controller which of the numbered functions should be acted upon. For profiles, there are 25 instances. Press the Infinity Key once to return to the submenu, twice to return to the main menu or three times to return to the Home Page.

Using Lockout to Hide Pages and Menus

If unintentional changes to parameter settings might raise safety concerns or lead to downtime, you can use the lockout feature to make them more secure.

These settings will affect any access using Standard Bus, including the RUI. This does not affect field protocol access.

Each of the menus in the Factory Page and each of the pages, except the Factory Page, has a security level assigned to it. You can change the read and write access to these menus and pages by using the parameters in the Lockout Menu (Factory Page).

Lockout Menu

There are five parameters in the Lockout Menu (Factory Page):

- Lock Operations Page **LoCo** sets the security level for the Operations Page. (default: 2)

Note:

The Home and Setup Page lockout levels are fixed and cannot be changed.

- Lock Profiling Page **LoCP** sets the security level for the Profiling Page. (default: 3)
- Password Security Enable **PRSE** will turn on or off the Password security feature. (default: off)
- Read Lockout Security **rLoC** determines which pages can be accessed. The user can access the selected level and all lower levels. (default: 5)
- Set Lockout Security **SLoC** determines which parameters within accessible pages can be written to. The user can write to the selected level and all lower levels. (default: 5)

The table that follows represents the various levels of lockout for the Set Lockout Security prompt and the Read Lockout Security prompt. The Set Lockout has 6 levels (0-5) of security where the Read Lockout has 5 (1-5). Therefore, level "0" applies to Set Lockout only. "Y" equates to yes (can write/read) where "N" equates to no (cannot write/read). The colored cells simply differentiate one level from the next.

Lockout Security <input type="checkbox"/> SLoC & <input type="checkbox"/> rLoC						
Lockout Level	0	1	2	3	4	5
Home Page	Y	Y	Y	Y	Y	Y
Operations Page	N	N	Y	Y	Y	Y
Setup Page	N	N	N	N	Y	Y
Profile Page	N	N	N	Y	Y	Y
Factory Page						
Custom Menu	N	N	N	N	N	Y
Diagnostic Menu	N	Y	Y	Y	Y	Y
Calibration Menu	N	N	N	N	N	Y
Lockout Menu						
<input type="checkbox"/> LoCo	N	Y	Y	Y	Y	Y
<input type="checkbox"/> LoCP	N	Y	Y	Y	Y	Y
<input type="checkbox"/> PRSE	N	Y	Y	Y	Y	Y
<input type="checkbox"/> rLoC	Y	Y	Y	Y	Y	Y
<input type="checkbox"/> SLoC	Y	Y	Y	Y	Y	Y

The following examples show how the Lockout Menu parameters may be used in applications:

1. You can lock out access to the Operations Page but allow an operator access to the Profile Menu, by changing the default Profile Page and Operations Page security levels. Change Lock Operations Page **[LoCo]** to 3. If Set Lockout Security **[SLoC]** is set to 2 or higher and the Read Lockout Security **[rLoC]** is set to 2, the Home Pages can be accessed, and all writable parameters can be written to. Pages with security levels greater than 2 will be locked out (inaccessible).
2. If Set Lockout Security **[SLoC]** is set to 0 and Read Lockout Security **[rLoC]** is set to 5, all pages will be accessible, however, changes will not be allowed on any pages or menus, with one exception: Set Lockout Security **[SLoC]** can be changed to a higher level.
3. The operator wants to read all the menus and not allow any parameters to be changed.
In the Factory Page, Lockout Menu, set Read Lockout Security **[rLoC]** to 5 and Set Lockout Security **[SLoC]** to 0.
4. The operator wants to read and write to the Home Page, and lock all other pages and menus.
In the Factory Page, Lockout Menu, set Read Lockout Security **[rLoC]** to 2 and Set Lockout Security **[SLoC]** to 2.
In the Factory Page, Lockout Menu, set Lock Operations Page **[LoCo]** to 3.
5. The operator wants to read the Operations Page, Setup Page, Profiling Page, Diagnostics Menu, Lock Menu, Calibration Menu and Custom Menus. The operator also wants to read and write to the Home Page.
In the Factory Page, Lockout Menu, set Read Lockout Security **[rLoC]** to 1 and Set Lockout Security **[SLoC]** to 5.
In the Factory Page, Lockout Menu, set Lock Operations Page **[LoCo]** to 2.

Using Password Security

It is sometimes desirable to apply a higher level of security to the control where a limited number of menus are visible and not providing access to others without a security password. Without the appropriate password those menus will remain inaccessible. If Password Enabled **[PASE]** in the Factory Page under the **[LoC]** Menu is set to on, an overriding Password Security will be in effect. When in effect, the only Pages that a User without a password has visibility to are defined in the Locked Access Level **[LoCL]** prompt. On the other hand, a User with a password would have visibility restricted by the Read Lockout Security **[rLoC]**. As an example, with Password Enabled and the Locked Access Level **[LoCL]** set to 1 and **[rLoC]** is set to 3, the available Pages for a User without a password would be limited to the Home and Factory Pages (locked level 1). If the

User password is entered all pages would be accessible with the exception of the Setup Page as defined by level 3 access.

How to Enable Password Security

Go to the Factory Page by holding down the Infinity **[∞]** key and the Advance **[➡]** key for approximately six seconds. Once there, push the Down **[▼]** key one time to get to the **[LoC]** menu. Again push the Advance **[➡]** key until the Password Enabled **[PASE]** prompt is visible. Lastly, push either the up or down key to turn it on. Once on, 4 new prompts will appear:

1. **[LoCL]**, Locked Access Level (1 to 5) corresponding to the lockout table above.
2. **[roLL]**, Rolling Password will change the Customer Code every time power is cycled.
3. **[PAS.u]**, User Password which is needed for a User to acquire access to the control.
4. **[PAS.A]**, Administrator Password which is needed to acquire administrative access to the control.

The Administrator can either change the User and or the Administrator password or leave them in the default state. Once Password Security is enabled they will no longer be visible to anyone other than the Administrator. As can be seen in the formula that follows either the User or Administrator will need to know what those passwords are to acquire a higher level of access to the control. Back out of this menu by pushing the Infinity **[∞]** key. Once out of the menu, the Password Security will be enabled.

How to Acquire Access to the Control

To acquire access to any inaccessible Pages or Menus, go to the Factory Page and enter the **[ULoC]** menu. Once there follow the steps below:

Note:



If Password Security (Password Enabled **[PASE]** is On) is enabled the two prompts mentioned below in the first step will not be visible. If unknown, call the individual or company that originally set-up the control.

1. Acquire either the User Password **[PAS.u]** or the Administrator Password **[PAS.A]**.
2. Push the Advance **[➡]** key one time where the Code **[CoDE]** prompt will be visible.

Note:

- a. If the the Rolling Password is off push the Advance key one more time where the Password **[PASS]** prompt will be displayed. Proceed to either step 7a or 8a. Pushing the Up **[▲]** or Down **[▼]** arrow keys enter either the User or Administrator Password. Once entered, push and hold the Infinity **[∞]** key for two seconds to return to the Home Page.
 - b. If the Rolling Password **[roLL]** was turned on proceed on through steps 3 - 9.
3. Assuming the Code **[CoDE]** prompt (Public Key) is still visible on the face of the control simply

push the Advance key  to proceed to the Password **[PASS]** prompt. If not find your way back to the Factory Page as described above.

4. Execute the calculation defined below (7b or 8b) for either the User or Administrator.
5. Enter the result of the calculation in the upper display play by using the Up  and Down  arrow keys or use EZ-ZONE Configurator Software.
6. Exit the Factory Page by pushing and holding the Infinity  key for two seconds.

Formulas used by the User and the Administrator to calculate the Password follows:

Passwords equal:

7. User

- a. If Rolling Password **[roll]** is Off, Password **[PASS]** equals User Password **[PASS.u]**.
- b. If Rolling Password **[roll]** is On, Password **[PASS]** equals:
 $(\text{PASS.u} \times \text{code}) \text{ Mod } 929 + 70$

8. Administrator

- a. If Rolling Password **[roll]** is Off, Password **[PASS]** equals Administrator Password **[PASS.A]**.
- b. If Rolling Password **[roll]** is On, Password **[PASS]** equals:
 $(\text{PASS.A} \times \text{code}) \text{ Mod } 997 + 1000$

Differences Between a User Without Password, User With Password and Administrator

- User **without** a password is restricted by the Locked Access Level **[LoL.L]**.
- A User **with** a password is restricted by the Read Lockout Security **[rLoL]** never having access to the Lock Menu **[LoL]**.
- An Administrator is restricted according to the Read Lockout Security **[rLoL]** however, the Administrator has access to the Lock Menu where the Read Lockout can be changed.

Software Configuration

Using EZ-ZONE® Configurator Software

To enable a user to configure the RME module using a personal computer (PC), Watlow has provided free software for your use. If you have not yet obtained a copy of this software insert the CD (Controller Support Tools) into your CD drive and install the software. Alternatively, if you are viewing this document electronically and have a connection to the internet simply click on the link below and download the software from the Watlow web site free of charge.

http://www.watlow.com/products/software/zone_config.cfm

Once the software is installed double click on the EZ-ZONE Configurator icon placed on your desktop during the installation process. If you cannot find the icon follow the steps below to run the software:

1. Move your mouse to the "Start" button
2. Place the mouse over "All Programs"
3. Navigate to the "Watlow" folder and then the sub-folder "EZ-ZONE Configurator"
4. Click on EZ-ZONE Configurator to run.

The first screen that will appear is shown below.



If the PC is already physically connected to the RME module click the next button to go on-line.

Note:

When establishing communications from PC to the RME module an interface converter will be required. The Standard Bus network uses EIA-485 as the interface. Most PCs today would require a USB to EIA-485 converter. However, some PCs may still be equipped with EIA-232 ports, therefore an EIA-232 to EIA-485 converter would be required.

As can be seen in the above screen shot the software provides the user with the option of downloading a previously saved configuration as well as the ability to create a configuration off-line to download later. The screen shots that follow will take the user on-line.

After clicking the next button above it is necessary to define the communications port on the PC to

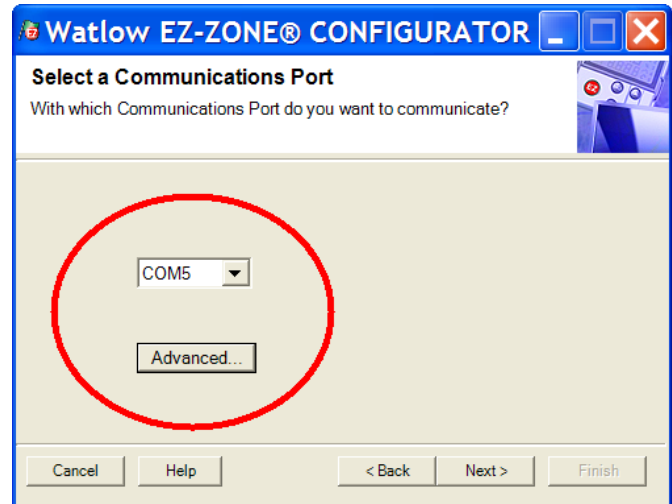

The available options allow the user to select "Try them all" or to use a specific known communications port. After installation of your converter if you are not sure which communications port was allocated select "Try them all" and then click next. The screen to follow shows that the software is scanning for devices on the network and that progress is being made.

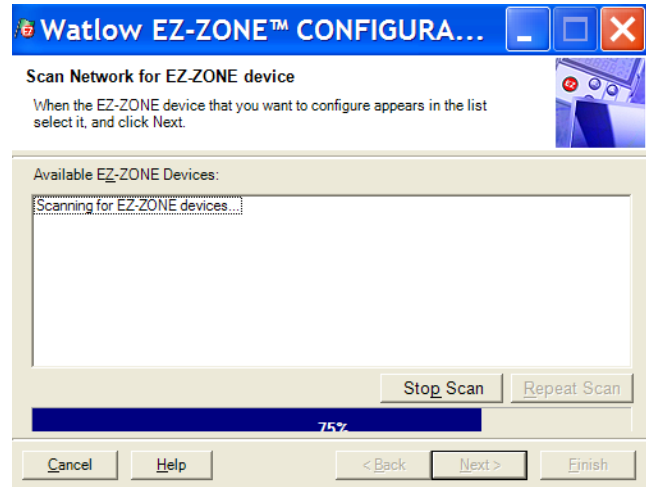

When complete the software will display all of the available devices found on the network as shown below.

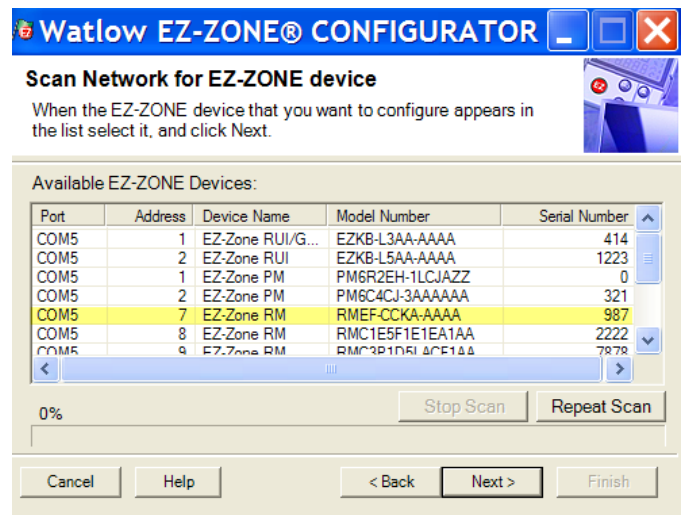

In the previous screen shot the RME is shown highlighted to bring greater clarity to the control in focus. Any EZ-ZONE device on the network will appear in this window and would be available for the purpose of configuration or monitoring. After clicking on the control of choice simply click the next button once again. The next screen appears below.

as an input, output parameters do not apply and are therefore grayed out. To speed up the process of configuration notice that at the bottom of the center column there is an option to copy settings. If all Digital I/O is to be set up the same click on "Copy Settings" where a copy from to copy to dialog box will appear allowing for quick duplication of all settings. Notice

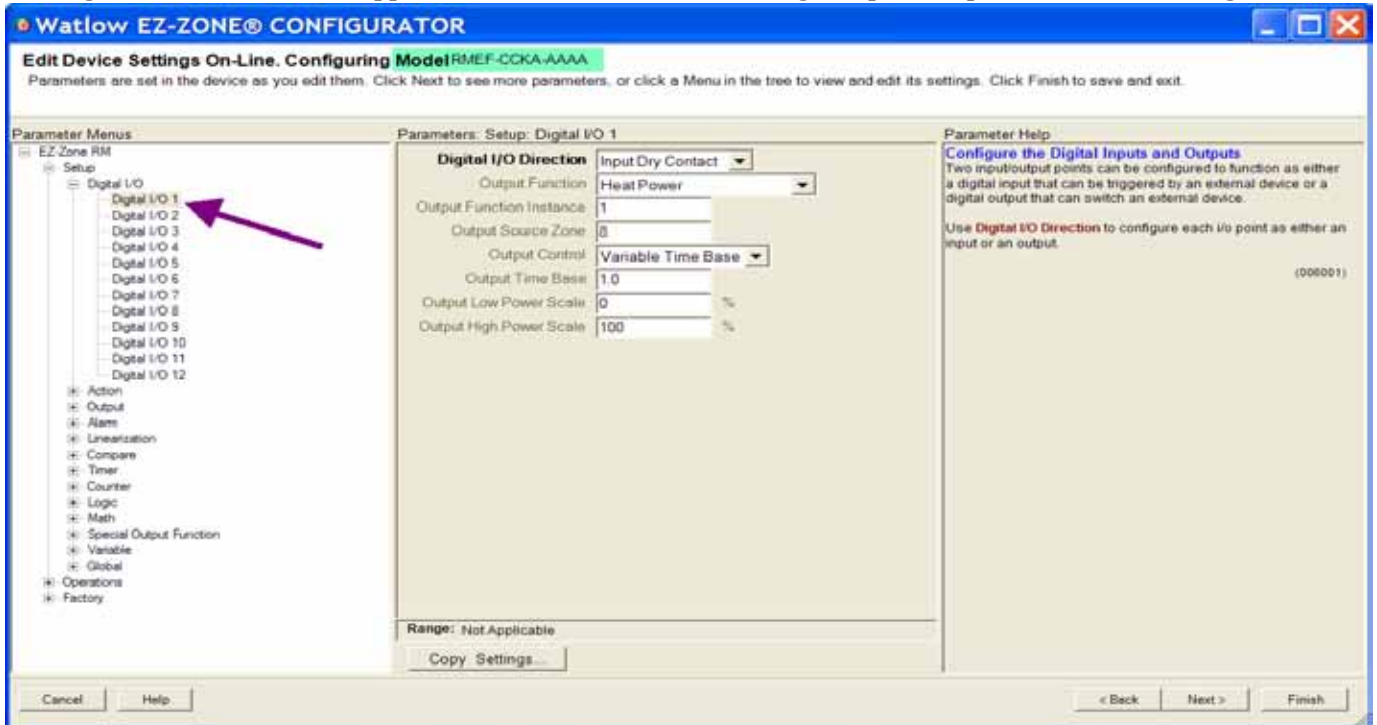

In the screen shot above notice that the device part number is clearly displayed at the top of the page (green highlight added for emphasis). When multiple EZ-ZONE devices are on the network it is important that the part number be noted prior to configuring so as to avoid making unwanted configuration changes to another control.

too, that by clicking on any of those items in the center column that context sensitive help will appear for that particular item in the right hand column.

Looking closely at the left hand column (Parameter Menus) notice that it displays all of the available menus and associated parameters within the RME. The menu structure as laid out within this software follows:

Lastly, when the configuration is complete click the "Finish" button at the bottom right of the previous screen shot. The screen that follows this action can be seen below.

- Setup
- Operations
- Factory

Navigating from one menu to the next is easy and clearly visible. Simply slide the scroll bar up or down to display the menu and parameter of choice. As an alternative, clicking on the negative symbol next to Setup will collapse the Setup Menu. The Operations Menu will appear next and perhaps deliver more clarity for the area of focus by not displaying unwanted menus and parameters. Once the focus is brought to an individual parameter (single click of mouse) as is the case for Digital I/O 1 in the left column, all that can be setup related to that parameter will appear in the center column. The grayed out fields in the center column simply mean that this does not apply for the type of sensor selected. As an example, notice that when Digital I/O 1 is configured

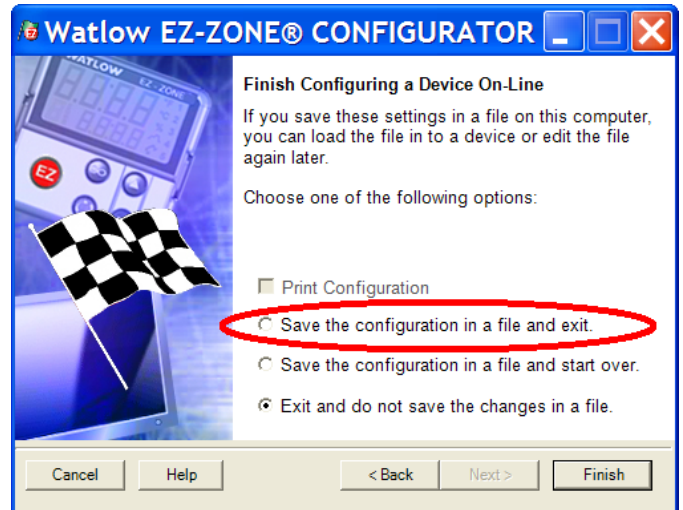

Although the RME module now contains the configuration (because the previous discussion focused on doing the configuration on-line) it is suggested that after the configuration process is completed that the user save this file on the PC for future use. If for some reason someone inadvertently changed a set-

ting without understanding the impact it would be easy and perhaps faster to download a saved configuration back to the control versus trying to figure out what was changed.

Of course, there is an option to exit without saving a copy to the local hard drive.

After selecting Save above click the "Finish" button once again. The screen below will than appear.



When saving the configuration note the location where the file will be placed (Saved in) and enter the file name (File name) as well. The default path for saved files follows:

`\My Documents\Watlow\EZ-ZONE CONFIGURATOR\Saved Configurations`

The user can save the file to any folder of choice.

Function Block Descriptions

Each of the next several pages graphically shows each of the RME function blocks. Note that as you view each you will find text that is black and text that appears gray. The gray text represents inputs that are not currently available based on the functions defined use (red text). For instance, when the defined use of the Alarm function is set to Off, all parameters will appear gray. Ranges specified are in units or degrees F, if expressed in degrees C, the range will be smaller.

Action Function

The Action Function will cause the action selected to occur when Source Function A = ON and Active Level = High. The active level specifies when the action occurs. A digital value that is high causes the action function when Active Level = High. A digital value that is low causes the action function when Active Level = Low. Based on a given input (Digital I/O, Event output, Logic function, etc), the Action function can cause other functions to occur. To name a few, starting and stopping a profile, silencing alarms, turn control loops off and placing alarms in non-alarm state.

Note:

Note: Action Function selection is module type and part number dependant.

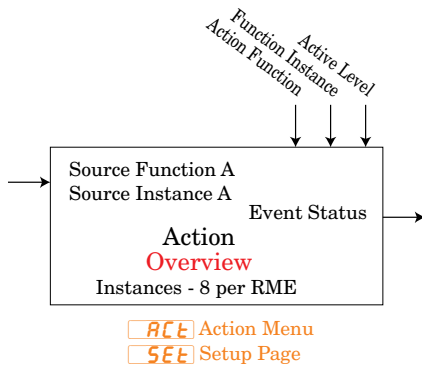

- F_n** Action Function : None, User Set Restore, Alarm, Silence Alarms, Control Loops Off and Alarms to Non-alarm State, Force Alarm to Occur
- F_i** Function Instance : 0 to 8
- SF_{nA}** Source Function A : None, Alarm, Compare, Counter, Digital I/O, Profile Event Out A to H, Function Key, Limit, Logic, Timer, Variable
- S_{iA}** Source Instance A : 1 to 24
- SZ_A** Source Zone A : 0 to 16
- LE_u** Active Level : High, Low

ACE Action Menu
 OPER Operation Page

- E_{iS}** Event Status : On, Off

Alarm Function

The Alarm function will cause the output to change states when Alarm Source exceeds Alarm Set Points.

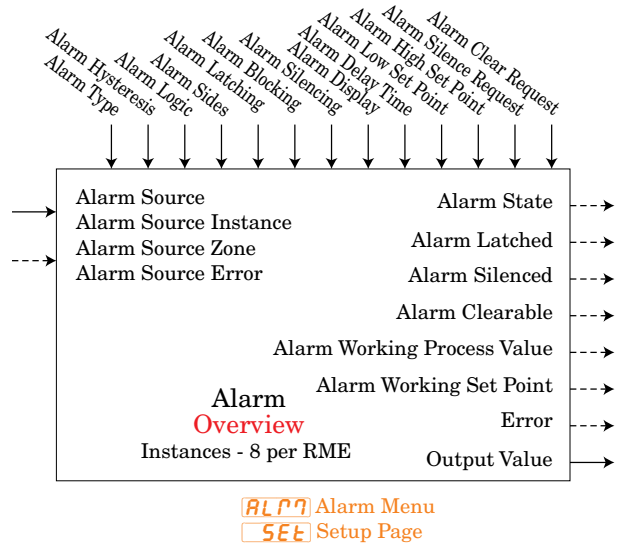

- AL_y** Alarm Type : Off, Process
- Sr_A** Alarm Source : Analog Input, Current, Power, Linearization, Math, Process Value, Variable
- S_{iA}** Alarm Source Instance : 1 to 24
- SZ_A** Alarm Source Zone : 0 to 16
- Ah_y** Alarm Hysteresis : 0.001 to 9,999.000
- AL_g** Alarm Logic : Close on Alarm, Open on Alarm
- AS_d** Alarm Sides : Both, High, Low
- AL_o** Alarm Low Set Point : -1,999.000 to 9,999.000
- Ah_i** Alarm High Set Point : -1,999.000 to 9,999.000
- AL_L** Alarm Latching : Non-Latching, Latching
- Ab_L** Alarm Blocking : Off, Startup, Set Point, Both
- AS_i** Alarm Silencing : Off, On
- AdSP** Alarm Display : Off, On
- Ad_L** Alarm Delay Time : 0 to 9,999 seconds

ALP Alarm Menu
 OPER Operation Page

- AL_o** Alarm Low Set Point : -1,999.000 to 9,999.000
- Ah_i** Alarm High Set Point : -1,999.000 to 9,999.000

- Alarm Clear Request : Ignore, Clear
- Alarm Silence Request : Ignore, Silence
- Alarm State : Startup, None, Blocked, Alarm Low, Alarm High, Error
- Alarm Latched : No, Yes
- Alarm Silenced : No, Yes
- Alarm Clearable : No, Yes
- Alarm Working Process Value : -1,999.000 to 9,999.000
- Alarm Working Set Point : -1,999.000 to 9,999.000
- Error : None, Open, Shorted, Measurement Error, Bad Cal Data, Ambient Error, Fail, Not Sourced
- Output Value : On, Off

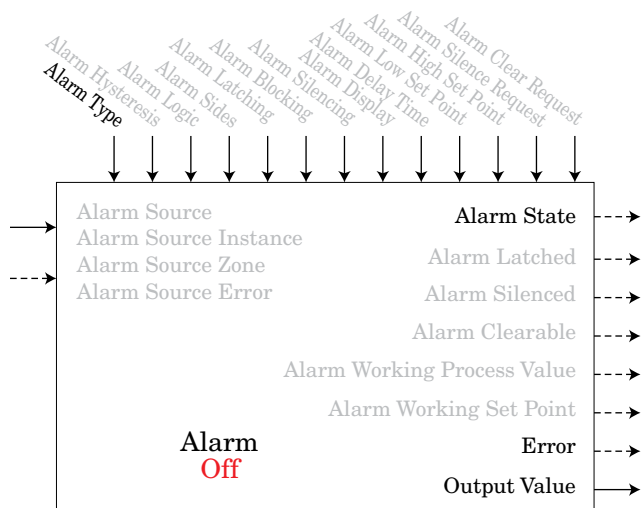

IF Type = Off THEN Output Value = OFF Alarm State = None and Alarm Indication = None

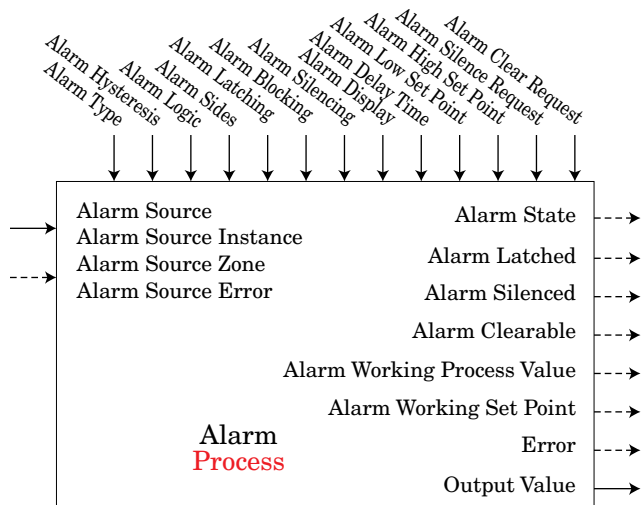

IF Type = Process THEN Alarm Variable = Process Value

Compare Function

Use this function to compare Source A to Source B and then drive the output based on the comparison. For the function to work properly, Source A and Source B must be without errors.

An error, when read, can indicate any of the following: None, Open, Shorted, Measurement Error, Bad Cal Data, Ambient Error, RTD Error, Fail, Math Error, Not Sourced, Stale

Tolerance is expressed in the same units as Source A.

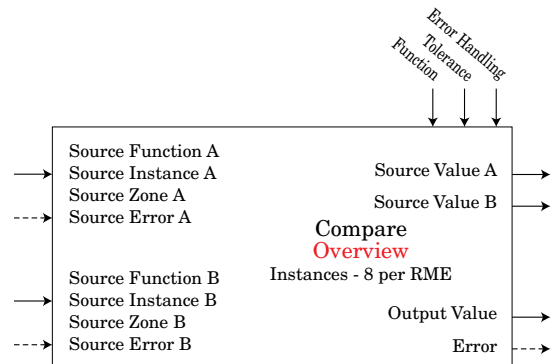

[\[CPE\]](#) Compare Menu
[\[SEE\]](#) Setup Page

- F_n** Function : Off, Greater Than, Less Than, Equal To, Not Equal To, Greater or Equal, Less or Equal
- t_{ol}** Tolerance : 0.0 to 9,999.000 units or F
- S_{F_nA}** Source Function A : None, Analog Input, Current, Cool Power, Heat Power, Power, Linearization, Math, Process Value, Set Point Closed, Set Point Open, Variable
- S_{I_A}** Source Instance A : 1 to 24
- S_{Z_A}** Source Zone A : 0 to 16
- S_{F_nB}** Source Function B : None, Analog Input, Current, Cool Power, Heat Power, Power, Linearization, Math, Process Value, Set Point Closed, Set Point Open, Variable
- S_{I_B}** Source Instance B : 1 to 24
- S_{Z_B}** Source Zone B : 0 to 16
- E_{r_h}** Error Handling : False Bad, False Good, True Bad, True Good

[\[CPE\]](#) Compare Menu
[\[OPER\]](#) Operation Page

- S_{v_A}** Source Value A : -1,999.000 to 9,999.000 units or F
- S_{v_B}** Source Value B : -1,999.000 to 9,999.000 units or F
- o_v** Output Value : Off, On

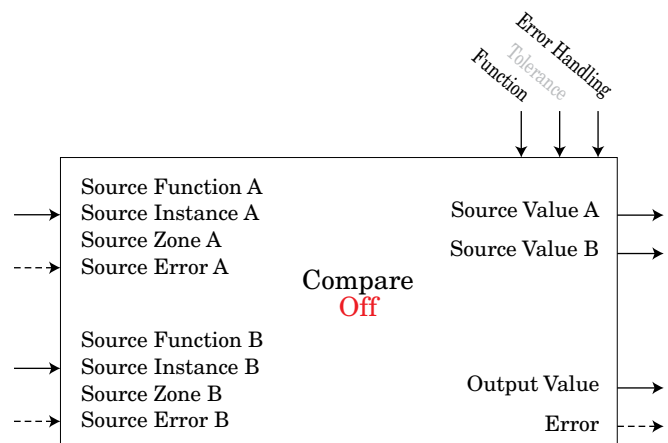

No Compare, Output Value = OFF

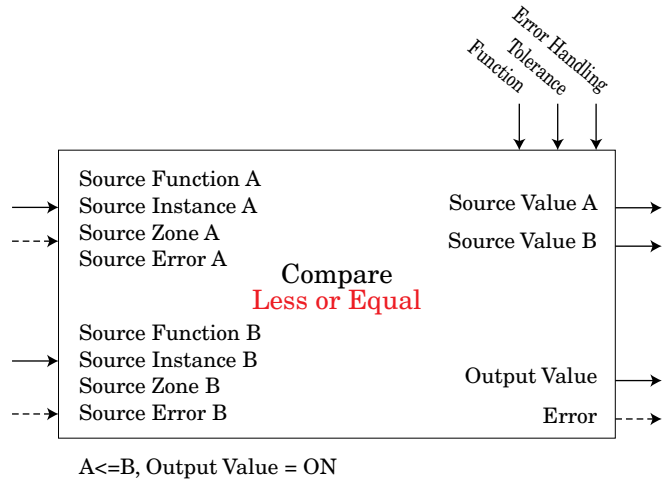
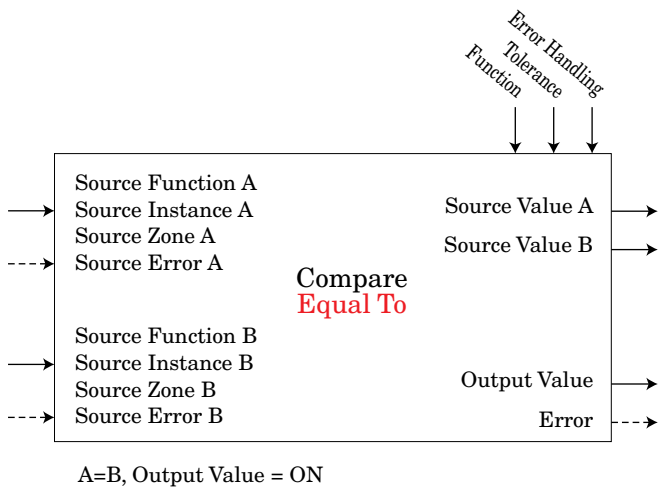
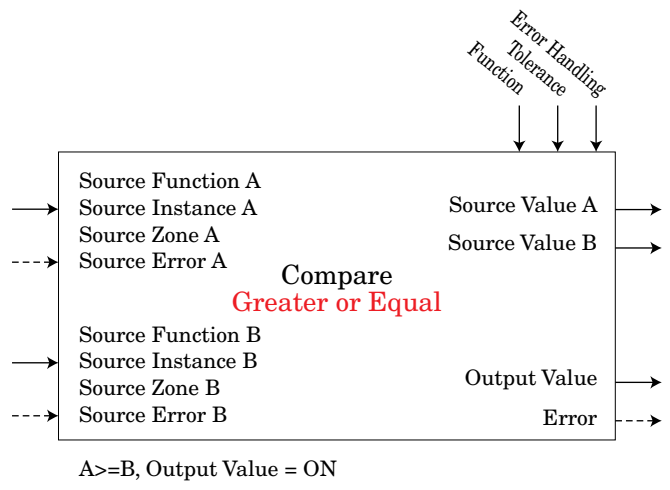
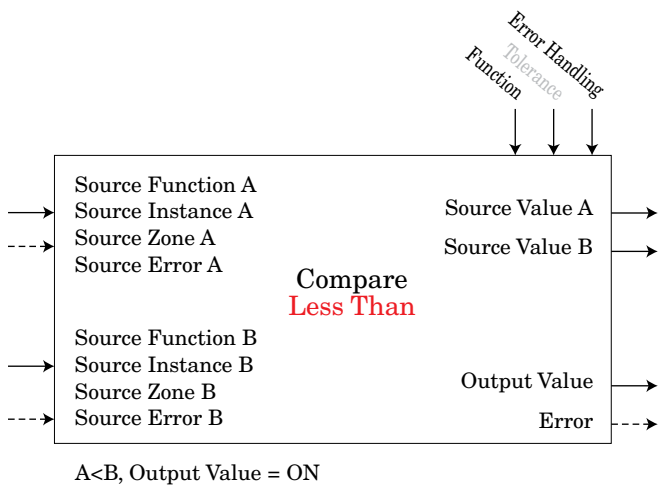
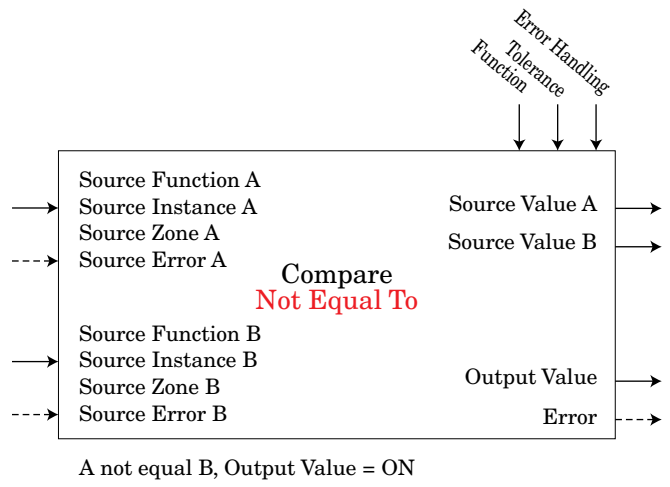
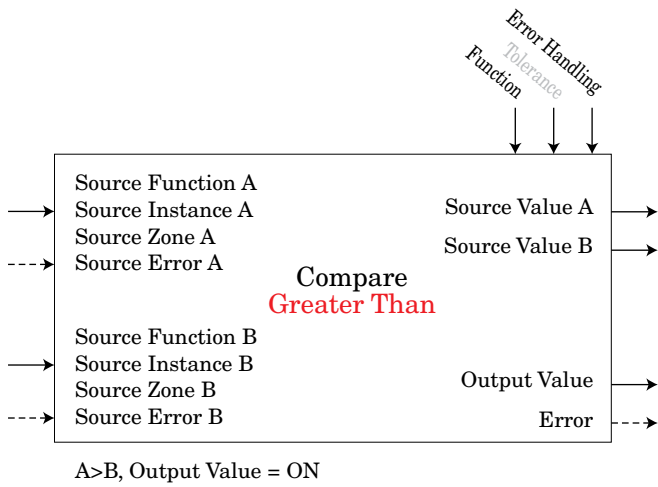

Counter Function

Function counts up or down from Load Value and produces Output Value = On when Count = Target Value.

Note:

Count value clears on power loss.

Load Value restored on power up.

Counter Operation:

Whenever a prescribed clock transition occurs without an error on source B the count will be equal to the Load Value.

If Function is an Up Counter:

Whenever a prescribed clock transition occurs without an error on Source A the count will increment by +1. If the count is equal to 9,999 when the transition occurs count will be 1 after transition.

If Function is a Down Counter:

Whenever a prescribed clock transition occurs without an error on Source A the count will decrement by -1. If the count is equal to 0 when the transition occurs the count will be 9,999 after transition.

An error, when read, can indicate any of the following:

None, Open, Shorted, Measurement Error, Bad Cal Data, Ambient Error, RTD Error, Fail, Math Error, Not Sourced, Stale

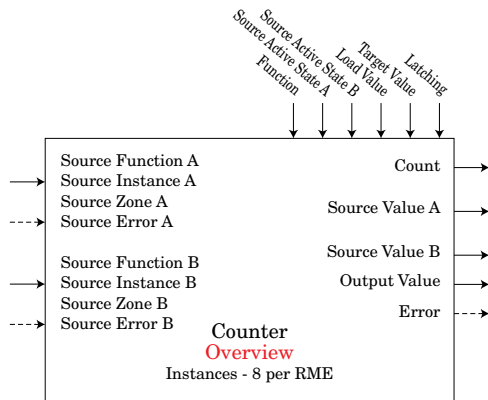

[Ctr] Counter Menu
[SEt] Setup Page

[Fn]	Function : Up, Down
[SFnA]	Source Function A (Clock) : None, Alarm, Compare, Counter, Digital I/O, Profile Event Out A to H, Function Key, Logic, Timer, Variable
[SIA]	Source Instance A : 1 to 24
[SZA]	Source Zone A : 0 to 16
[SASA]	Source Active State A (Active State Clock) : High (rising), Low (falling), Both (rising & falling)
[SFnb]	Source Function B (Load) : None, Alarm, Compare, Counter, Digital I/O, Profile Event Out A to H, Function Key, Logic, Timer, Variable
[SIB]	Source Instance B : 1 to 24
[SZB]	Source Zone B : 0 to 16
[SASB]	Source Active State B (Active State Load) : High, Low
[LdV]	Load Value : 0 to 9,999
[TgV]	Target Value : 0 to 9,999
[Lch]	Latching : No, Yes

[Ctr] Counter Menu
[SEt] Operation Page

[Cnt]	Count : 0 to 9,999
[SvA]	Source Value A : Off, On
[SvB]	Source Value B : Off, On
[oV]	Output Value : Off, On

Custom Function

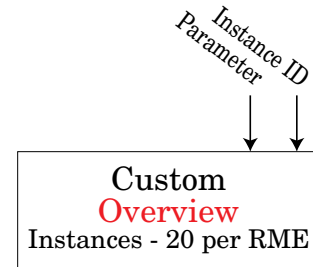

[CUsE] Custom Menu
[FAcE] Factory Page

[PAR]	Parameter : None, Display Units, User Settings Restore, Alarm Low Set Point, Alarm High Set Point, Alarm Hysteresis, Custom
[IID]	Instance ID : 1 to 24

Diagnostic Function

This function allows the user to view module specific information that may be useful when troubleshooting.

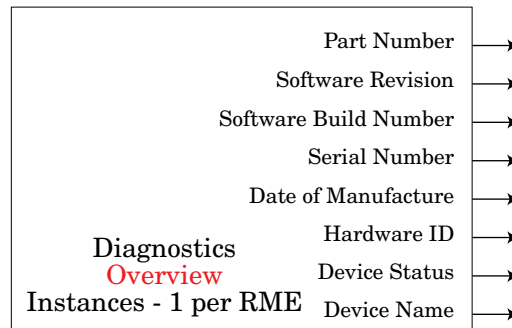

[dIAG] Diagnostics Menu
[FAcE] Factory Page

[Pn]	Part Number: scrolls on display
[rEv]	Software Revision: 1.00, ...
[SbLd]	Software Build Number : 0, 1, 2, ...
[Sn]	Serial Number : xxxxxx
[dMfE]	Date of Manufacture : YWW format

Hardware ID : 24 or 117 (RME)

Device Status : OK, Fail

Device Name : EZ-ZONE RM

Digital Input/Output Function

Note:

Input value is passed to any specified digital input source when programmed as input by that function block.

Output value determine by Function Block driving this output.

Digital I/O Value : On, Off

An error, when read, can indicate any of the following:
None, Open, Shorted, Measurement Error, Bad Cal Data, Ambient Error, RTD Error, Fail, Math Error, Not Sourced, Stale

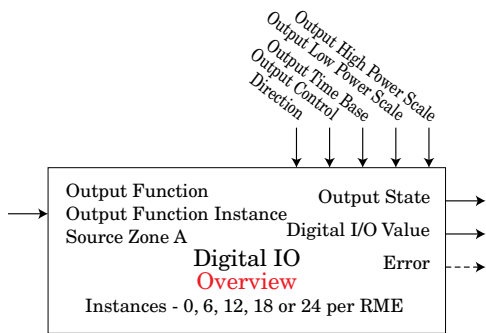

[d i o] Digital I/O Menu
[S E E] Setup Page

- [d i r]** Direction : Output, Input Contact, Input Voltage
- [F n]** Output Function : Off, Analog Input, Alarm, Cool Power, Heat Power, Compare, Counter, Digital I/O, Profile Event Out A to H, Function Key, Logic, Linearization, Math, Process Value, Special Function Output 1 to 4, Timer, Variable
- [F i]** Output Function Instance : 1 to 24
- [S Z A]** Source Zone A : 0 to 16
- [o c t]** Output Control : Fixed Time Base, Variable Time Base
- [o t b]** Output Time Base : 0.1 to 60.0 seconds
- [o l o]** Output Low Power Scale : 0.0 to 100.0 %
- [o h i]** Output High Power Scale : 0.0 to 100.0 %

[d i o] Digital I/O Menu
[S E E] Operation Page

- [d i s]** Input State : On, Off
- [d o s]** Output State : On, Off

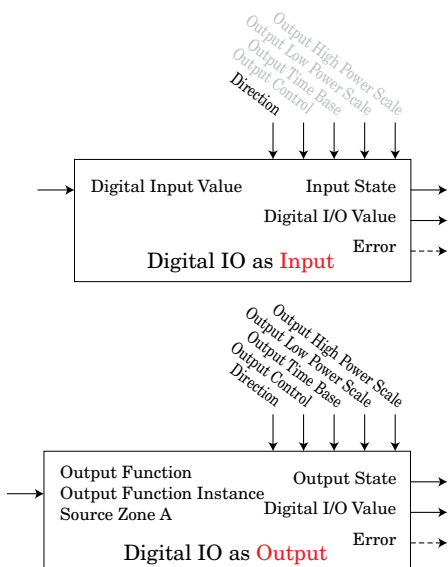

Global Function

This function allows the user to change display units as well as save and restore user settings.

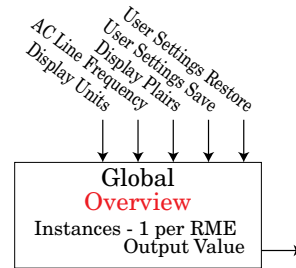

[g l b l] Global Menu
[S E E] Setup Page

- [C _ F]** Display Units : F, C
- [R L F]** AC Line Frequency : 50 Hz, 60 Hz
- [d P r S]** Display Pairs : 1 to 10
- [U S r S]** User Settings Save : None, User Set 1, User Set 2
- [U S r r]** User Settings Restore : None, User Set 1, User Set 2, Factory

Linearization Function

This function will take an analog Source A and re-linearize using a 10-point offset, then add Offset and produce an Output Value.

An error, when read, can indicate any of the following:
None, Open, Shorted, Measurement Error, Bad Cal Data, Ambient Error, RTD Error, Fail, Math Error, Not Sourced, Stale

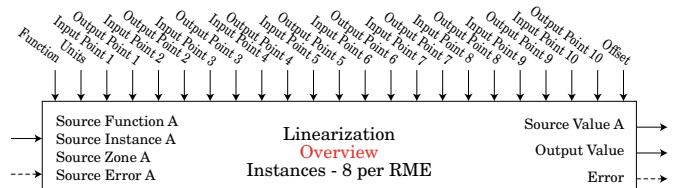

[L n r] Linearization
[S E E] Setup Page

- [F n]** Function : Off, Interpolated, Stepped
- [S F n A]** Source Function A : None, Analog Input, Current, Cool Power, Heat Power, Power, Linearization, Math, Process Value, Set Point Closed, Set Point Open, Variable
- [S I A]** Source Instance A : 1 to 24
- [S Z A]** Source Zone A : 0 to 16
- [U n i t]** Units : Source, None, Absolute Temperature, Relative Temperature, Power, Process, Relative Humidity
- [i P 1]** Input Point 1 : -1,999.000 to 9,999.000
- [o P 1]** Output Point 1 : -1,999.000 to 9,999.000
- [i P 2]** Input Point 2 : -1,999.000 to 9,999.000
- [o P 2]** Output Point 2 : -1,999.000 to 9,999.000
- [i P 3]** Input Point 3 : -1,999.000 to 9,999.000
- [o P 3]** Output Point 3 : -1,999.000 to 9,999.000
- [i P 4]** Input Point 4 : -1,999.000 to 9,999.000
- [o P 4]** Output Point 4 : -1,999.000 to 9,999.000
- [i P 5]** Input Point 5 : -1,999.000 to 9,999.000
- [o P 5]** Output Point 5 : -1,999.000 to 9,999.000
- [i P 6]** Input Point 6 : -1,999.000 to 9,999.000
- [o P 6]** Output Point 6 : -1,999.000 to 9,999.000
- [i P 7]** Input Point 7 : -1,999.000 to 9,999.000
- [o P 7]** Output Point 7 : -1,999.000 to 9,999.000
- [i P 8]** Input Point 8 : -1,999.000 to 9,999.000
- [o P 8]** Output Point 8 : -1,999.000 to 9,999.000
- [i P 9]** Input Point 9 : -1,999.000 to 9,999.000
- [o P 9]** Output Point 9 : -1,999.000 to 9,999.000
- [i P 10]** Input Point 10 : -1,999.000 to 9,999.000
- [o P 10]** Output Point 10 : -1,999.000 to 9,999.000

S **u** **A** Source Value A : -1,999.000 to 9,999.000
a **F** **S** **E** Offset : -1,999.000 to 9,999.000
a **u** Output Value : -1,999.000 to 9,999.000

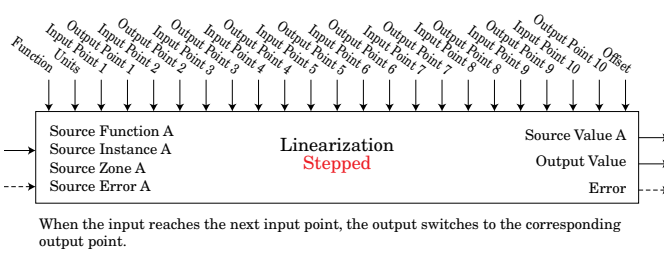
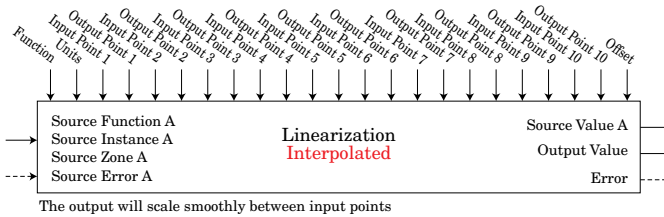
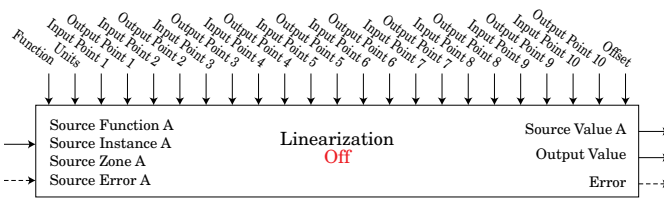

- F** **n** Function : Off, AND, OR, Equal To, NAND, NOR, Not Equal To, Latch, RS Flip Flop
- S** **F** **n** **A** Source Function A : None, Alarm, Compare, Counter, Digital I/O, Profile Event Out A to H, Function Key, Limit, Logic, Special Function Output 1 to 4, Timer, Variable
- S** **i** **A** Source Instance A : 1 to 24
- S** **Z** **A** Source Zone A : 0 to 16
- S** **F** **n** **b** Source Function B : None, Alarm, Compare, Counter, Digital I/O, Profile Event Out A to H, Function Key, Limit, Logic, Special Function Output 1 to 4, Timer, Variable
- S** **i** **b** Source Instance B : 1 to 24
- S** **Z** **b** Source Zone B : 0 to 16
- S** **F** **n** **c** Source Function C : None, Alarm, Compare, Counter, Digital I/O, Profile Event Out A to H, Function Key, Limit, Logic, Special Function Output 1 to 4, Timer, Variable
- S** **i** **c** Source Instance C : 1 to 24
- S** **Z** **c** Source Zone C : 0 to 16
- S** **F** **n** **d** Source Function D : None, Alarm, Compare, Counter, Digital I/O, Profile Event Out A to H, Function Key, Limit, Logic, Special Function Output 1 to 4, Timer, Variable
- S** **i** **d** Source Instance D : 1 to 24
- S** **Z** **d** Source Zone D : 0 to 16
- S** **F** **n** **e** Source Function E : None, Alarm, Compare, Counter, Digital I/O, Profile Event Out A to H, Function Key, Limit, Logic, Special Function Output 1 to 4, Timer, Variable
- S** **i** **e** Source Instance E : 1 to 24
- S** **Z** **e** Source Zone E : 0 to 16
- S** **F** **n** **f** Source Function F : None, Alarm, Compare, Counter, Digital I/O, Profile Event Out A to H, Function Key, Limit, Logic, Special Function Output 1 to 4, Timer, Variable
- S** **i** **f** Source Instance F : 1 to 24
- S** **Z** **f** Source Zone F : 0 to 16
- S** **F** **n** **g** Source Function G : None, Alarm, Compare, Counter, Digital I/O, Profile Event Out A to H, Function Key, Limit, Logic, Special Function Output 1 to 4, Timer, Variable
- S** **i** **g** Source Instance G : 1 to 24
- S** **Z** **g** Source Zone G : 0 to 16
- S** **F** **n** **h** Source Function H : None, Alarm, Compare, Counter, Digital I/O, Profile Event Out A to H, Function Key, Limit, Logic, Special Function Out 1 to 4, Timer, Variable
- S** **i** **h** Source Instance H : 1 to 24
- S** **Z** **h** Source Zone H : 0 to 16
- E** **r** **r** **h** Error Handling : True Good, True Bad, False Good, False Bad

Logic Function

This function allows the user to perform a logical operation on up to 8 inputs and then drive its output based on the operation.

An error, when read, can indicate any of the following: None, Open, Shorted, Measurement Error, Bad Cal Data, Ambient Error, RTD Error, Fail, Math Error, Not Sourced, Stale

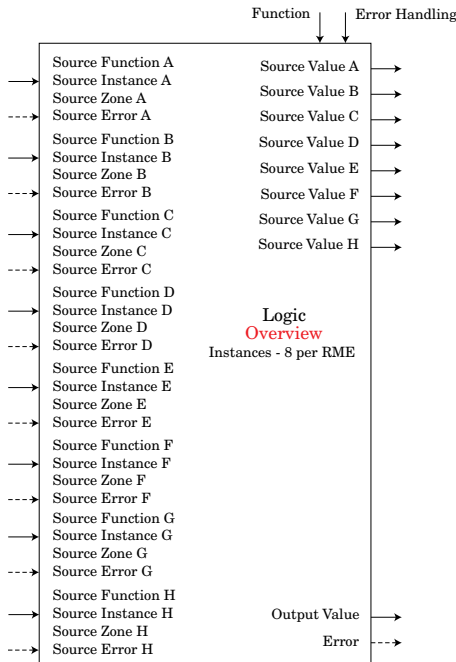

- S** **u** **A** Source Value A : Off, On
- S** **u** **b** Source Value B : Off, On
- S** **u** **c** Source Value C : Off, On
- S** **u** **d** Source Value D : Off, On
- S** **u** **e** Source Value E : Off, On
- S** **u** **f** Source Value F : Off, On
- S** **u** **g** Source Value G : Off, On
- S** **u** **h** Source Value H : Off, On
- a** **u** Output Value : Off, On

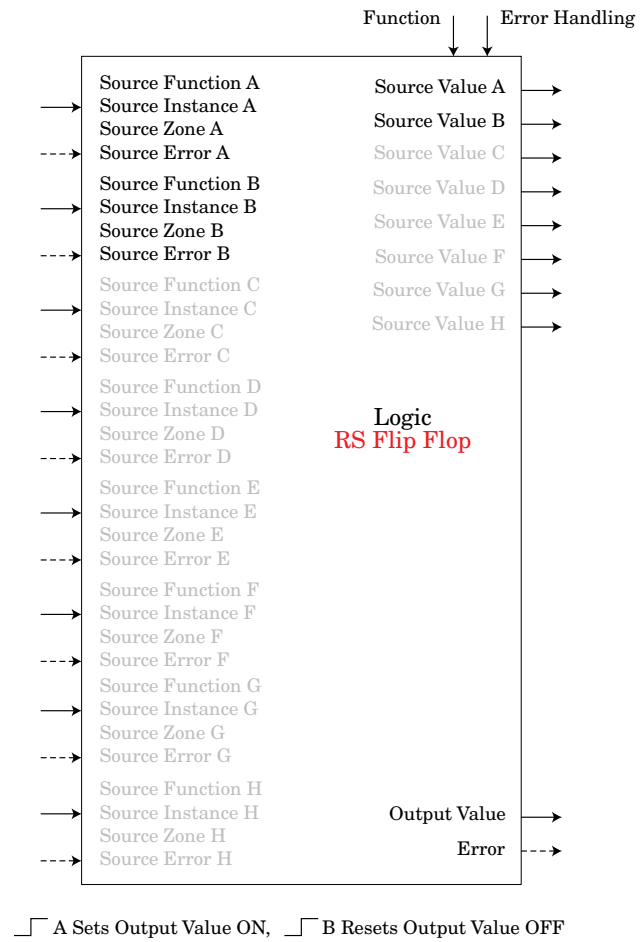
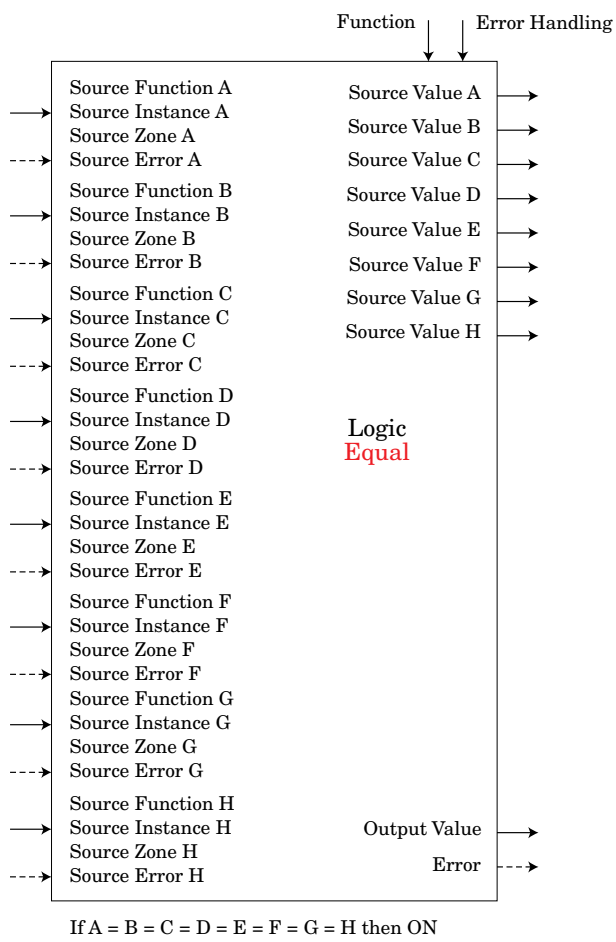
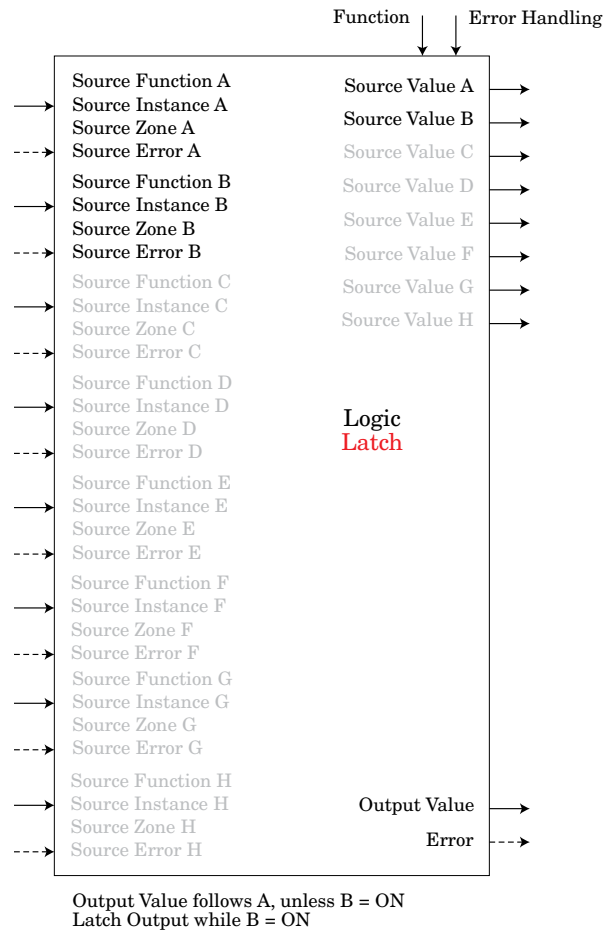
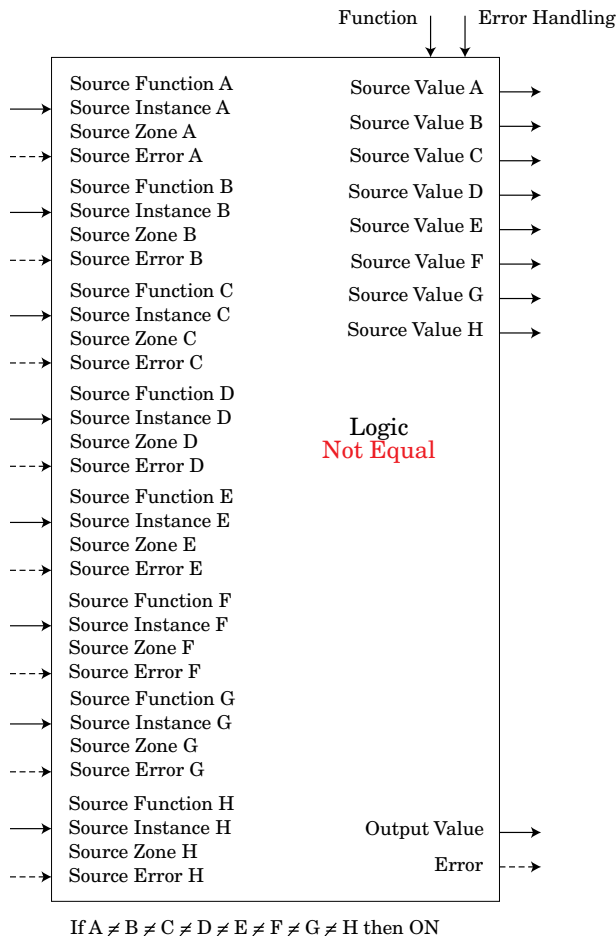

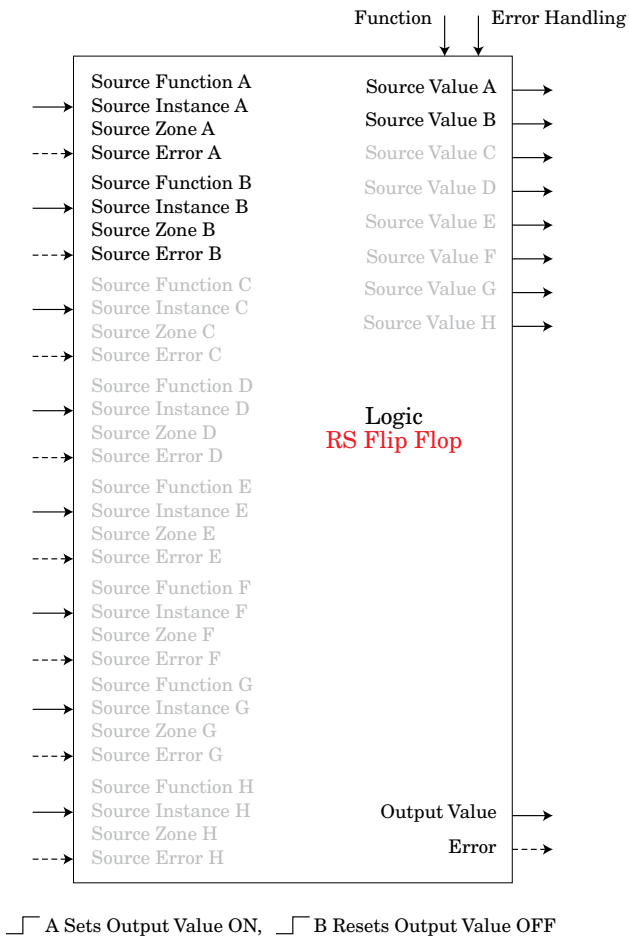

Math Function

The Math function block accepts multiple inputs and performs a programmed math function to derive an output value with Filter and Offset values applied. It is assumed that no input error conditions apply. Some math operations must be performed in the user's units.

Functions may combine multiple inputs. Those inputs may have incompatible units from a logical point of view. As a result, unless otherwise indicated, the presentation of the output value is the same as Source A. This accommodates temperatures being multiplied, divided and offset by constants and process inputs. Only inputs pointed to a source are used in the calculations.

An error, when read, can indicate any of the following: None, Open, Shorted, Measurement Error, Bad Cal Data, Ambient Error, RTD Error, Fail, Math Error, Not Sourced, Stale

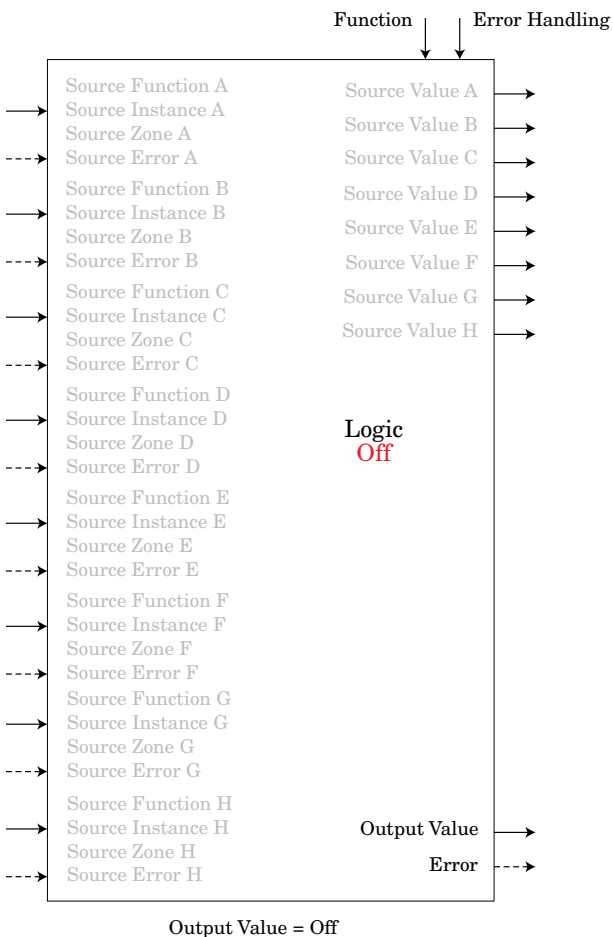
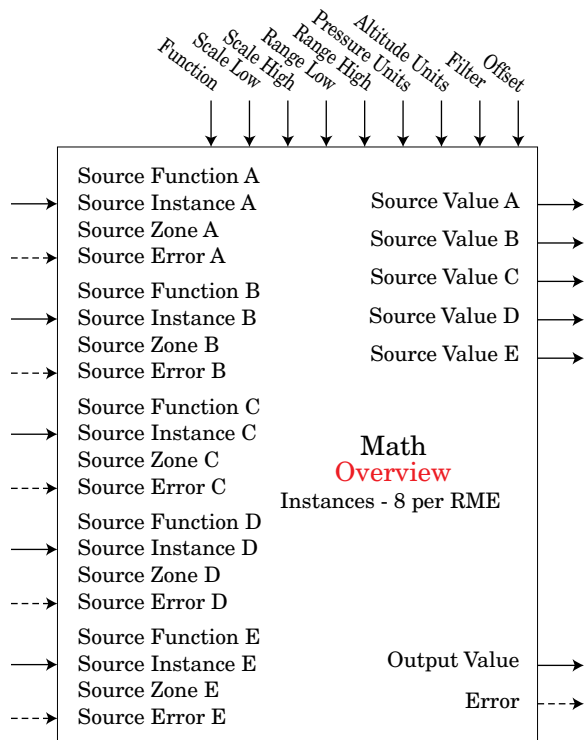

- F** Function : Off, Average, Process Scale, Deviation Scale, Switch Over, Differential, Ratio, Add, Multiply, Absolute Difference, Minimum, Maximum, Square Root, Sample and Hold, Pressure to Altitude, Dewpoint
- SFn** Source Function A : None, Analog Input, Current, Cool Power, Heat Power, Power, Linearization, Math, Process Value, Set Point Closed, Set Point Open, Variable
- SiA** Source Instance A : 1 to 24
- SZA** Source Zone A : 0 to 16
- SFnB** Source Function B : None, Analog Input, Current, Cool Power, Heat Power, Power, Linearization, Math, Process Value, Set Point Closed, Set Point Open, Variable
- SiB** Source Instance B : 1 to 24
- SZB** Source Zone B : 0 to 16
- SFnC** Source Function C : None, Analog Input, Current, Cool Power, Heat Power, Power, Linearization, Math, Process Value, Set Point Closed, Set Point Open, Variable
- SiC** Source Instance C : 1 to 24
- SZC** Source Zone C : 0 to 16
- SFnD** Source Function D : None, Analog Input, Current, Cool Power, Heat Power, Power, Linearization, Math, Process Value, Set Point Closed, Set Point Open, Variable
- SiD** Source Instance D : 1 to 24
- SZD** Source Zone D : 0 to 16
- SFnE** Source Function E : None, Alarm, Compare, Counter, Digital I/O, Profile Event Out A to H, Function Key, Logic, Timer, Variable
- SiE** Source Instance E : 1 to 24
- SZE** Source Zone E : 0 to 16
- SL** Scale Low : -1,999.0 to 9,999.0
- SH** Scale High : -1,999.0 to 9,999.0
- RL** Range Low : -1,999.0 to 9,999.0
- RH** Range High : -1,999.0 to 9,999.0
- PUnit** Pressure Units : PSI, Torr, mBar, Atmosphere, Pascal
- AUnit** Altitude Units : Feet, Kilofeet
- FiL** Filter : 0.0 to 60.0 seconds

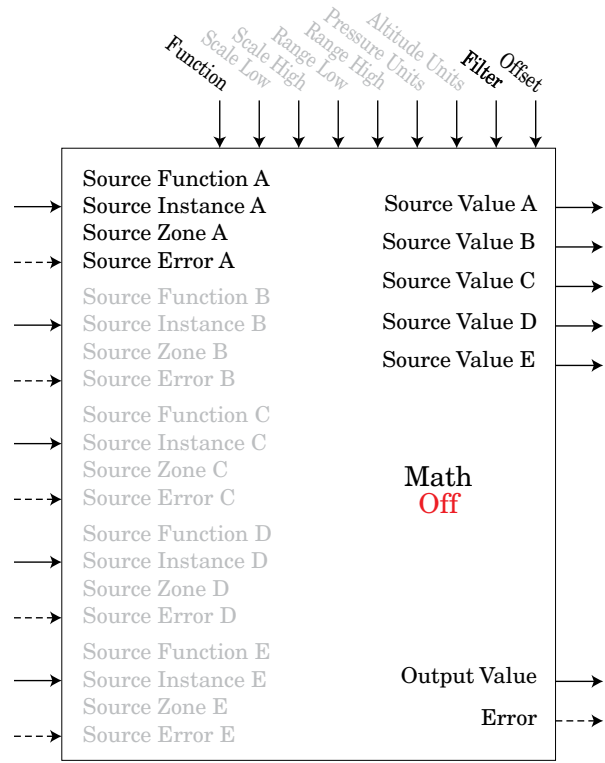

Output Value = Filter [A + Offset]
 Display units follows Source A

- SuA** Source Value A : -1,999.000 to 9,999.000
- SuB** Source Value B : -1,999.000 to 9,999.000
- SuC** Source Value C : -1,999.000 to 9,999.000
- SuD** Source Value D : -1,999.000 to 9,999.000
- SuE** Source Value E : Off, On
- oV** Output Value : -1,999.000 to 9,999.000
- oFSE** Offset : -1,999.000 to 9,999.000

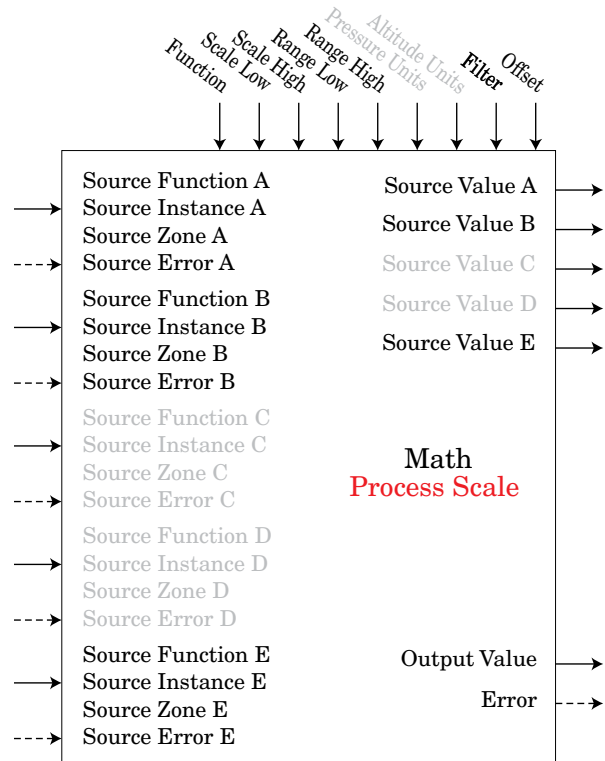

If E = OFF, Output Value = Filter [(Range High - Range Low) / (Scale High - Scale Low) * (A - Scale Low) + Range Low + Offset]
 If B = ON, Output Value = Filter [B + Offset]

Scale Low/High and Range Low/High follows Source A display units.

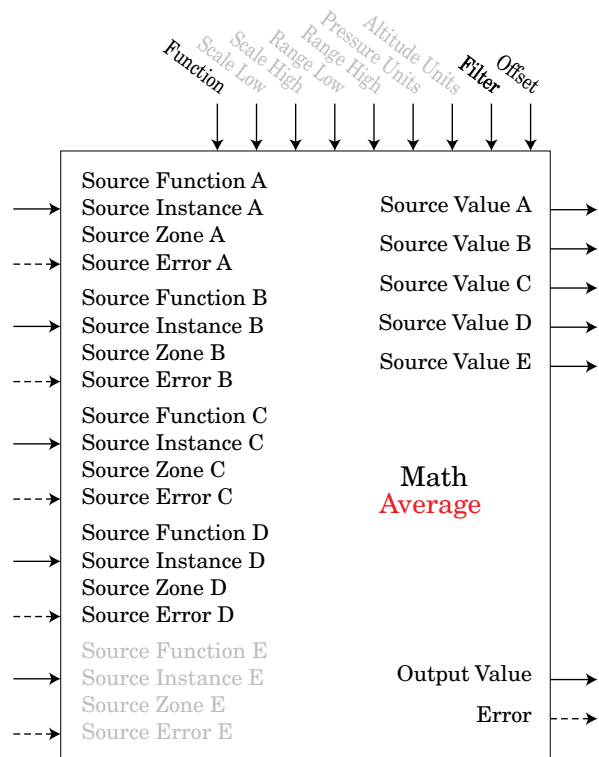

Output Value = Filter [(Average (A + B + C + D)) + Offset]
 Display units follows the last source that is temperature else follow Source A

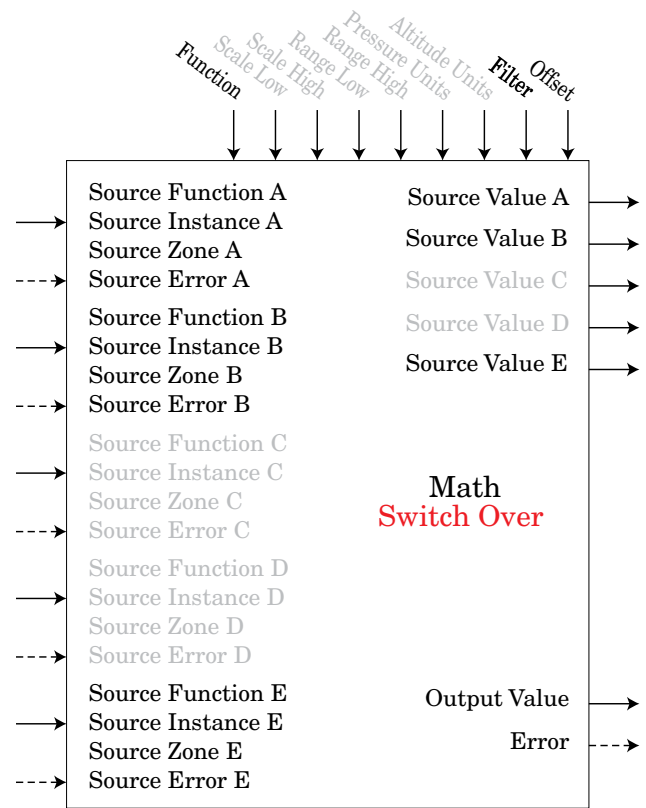

If E = OFF, Output Value = Filter [A + Offset]
 If E = ON, Output Value = Filter [B + Offset]
 Display units follows active source.

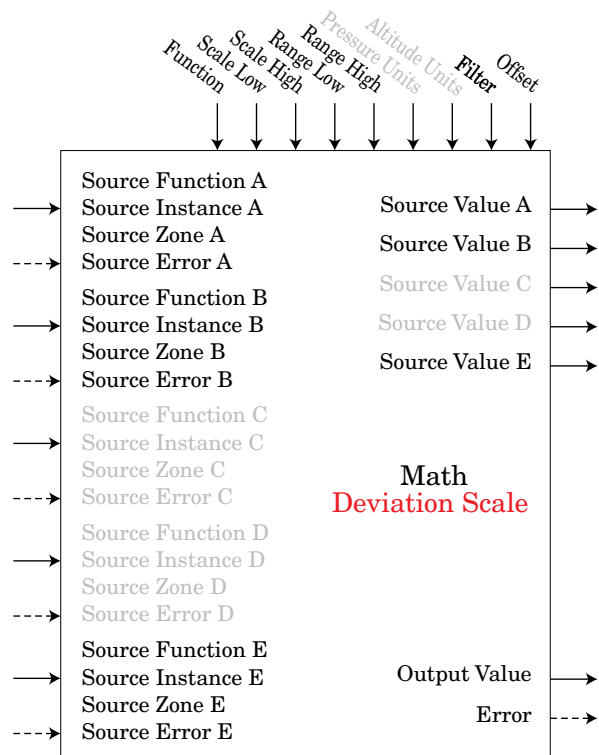

If E = OFF, Output Value = Filter [((Range High - Range Low) / (Scale High - Scale Low)) * (A - Scale Low) + Range Low + B + Offset]
 If E = ON, Output Value = Filter [B + Offset]

Scale Low/High and Range Low/High follows Source A display units.

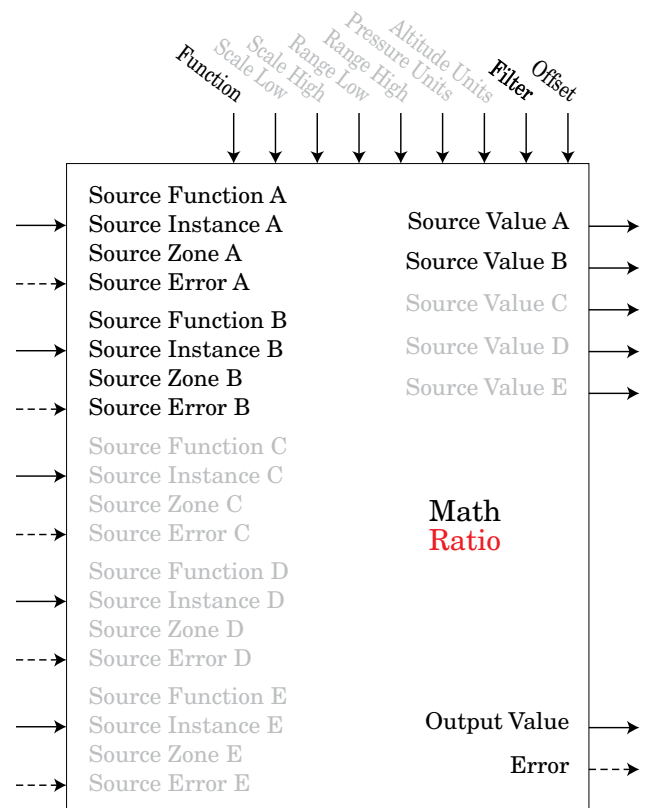

Output Value = Filter [(A / B) + Offset]
 If display units of Source A = Source B, no display units on output value, else follow Source A

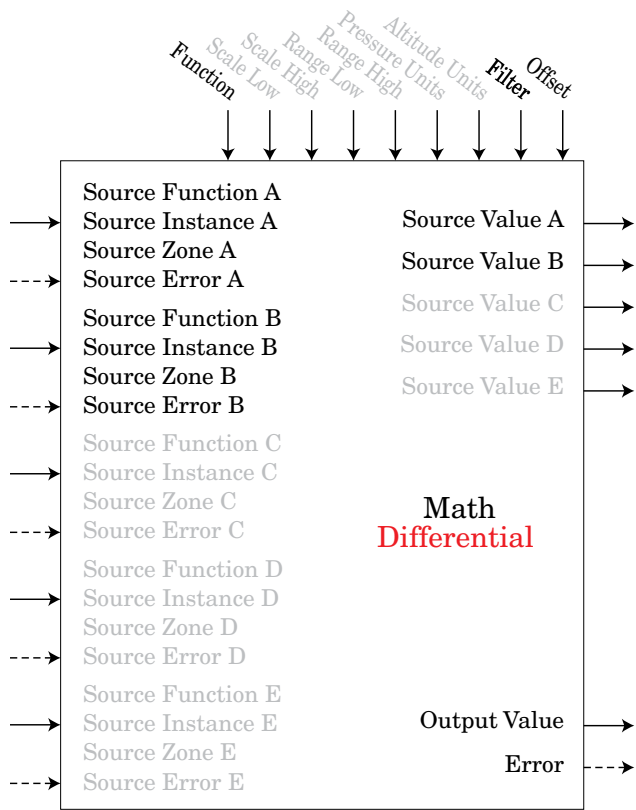

Output Value = Filter [(A - B) + Offset]
Display units follows Source A plus relative Source B

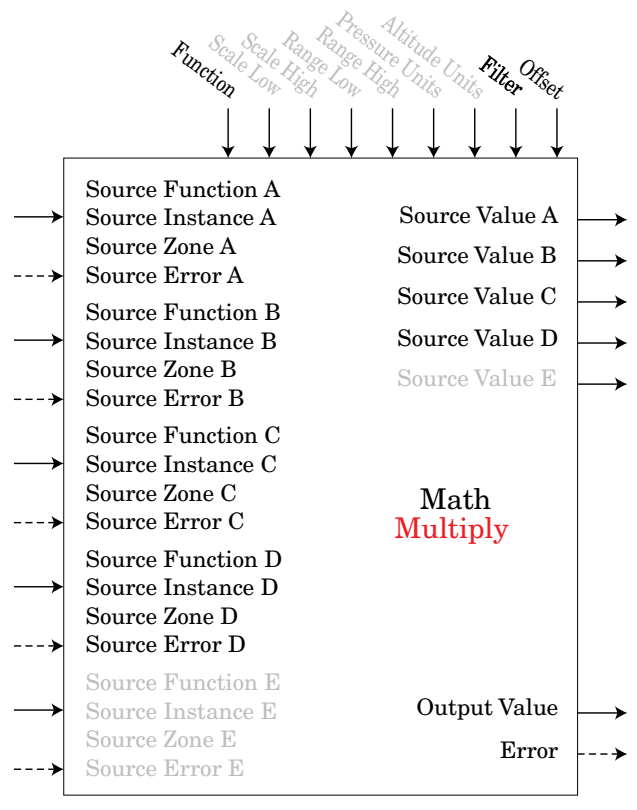

Output Value = Filter [(A * B * C * D) + Offset]
Display units follows last temperature source else follow Source A

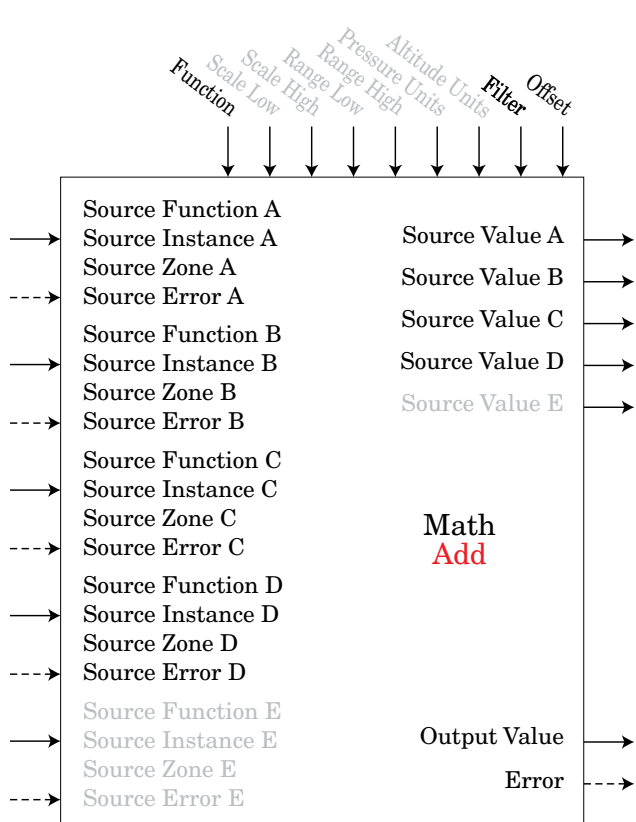

Output Value = Filter [(A + B + C + D) + Offset]
Display units follows last temperature source else follow Source A

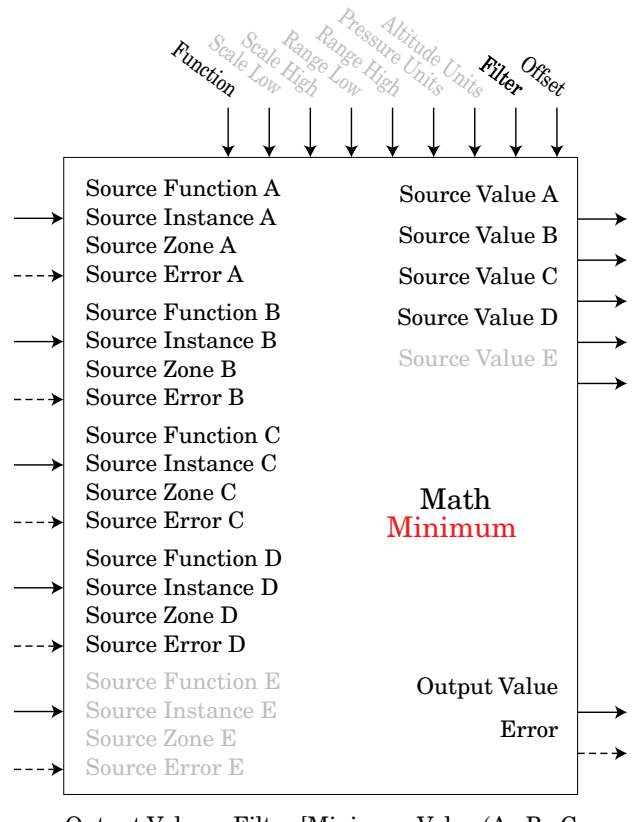

Output Value = Filter [Minimum Value (A : B : C : D) + Offset]
Display units follows Source with minimum value.

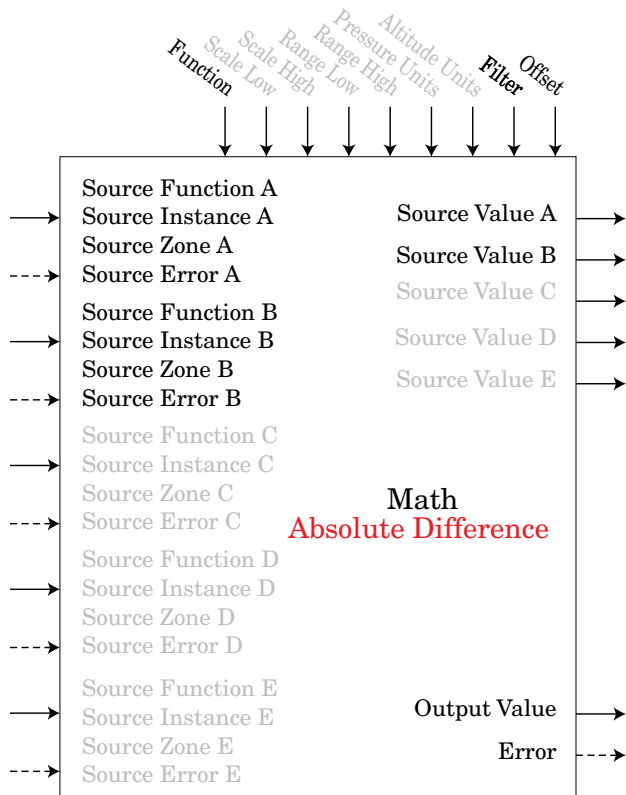

Output Value = Filter [| A - B | + Offset]
 Display units follow Source A plus relative Source B

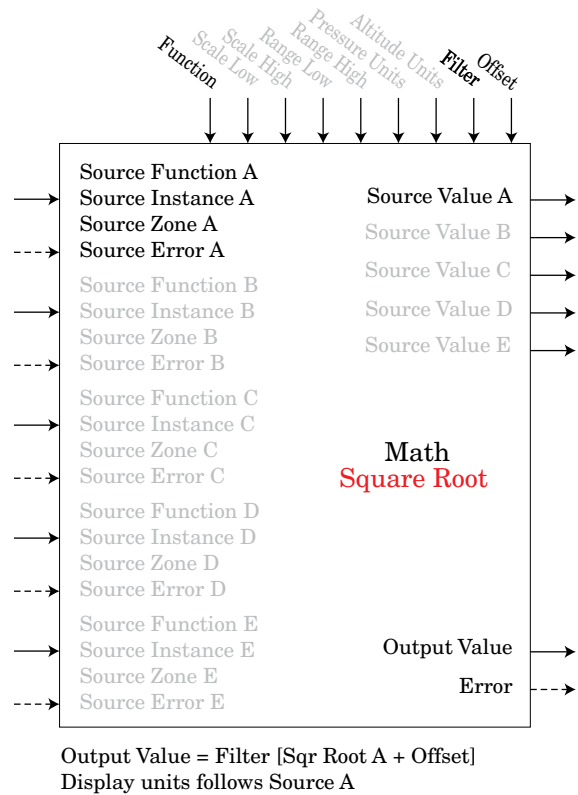

Output Value = Filter [Sqr Root A + Offset]
 Display units follows Source A

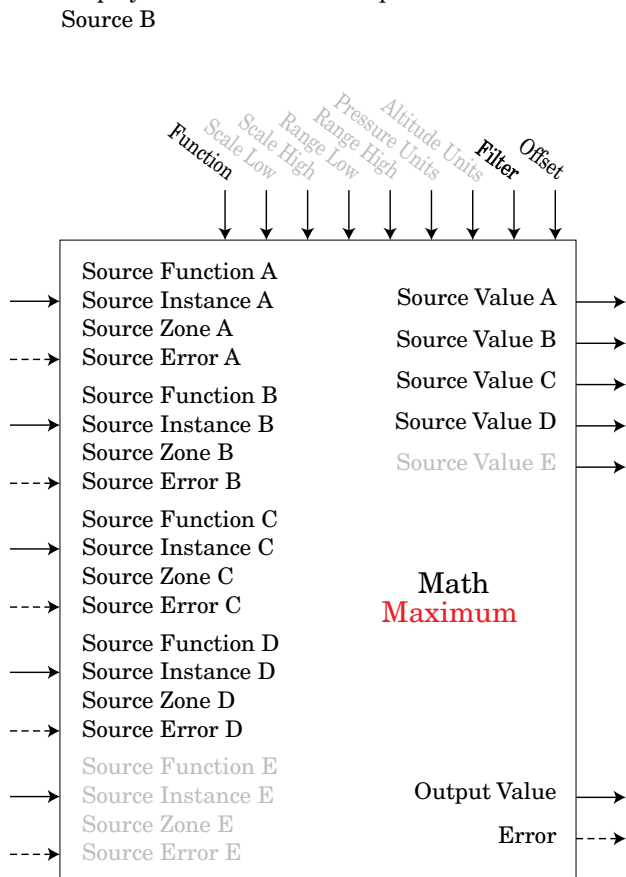

Output Value = Filter [Maximum Value (A : B : C : D) + Offset]
 Display units follows Source with maximum value.

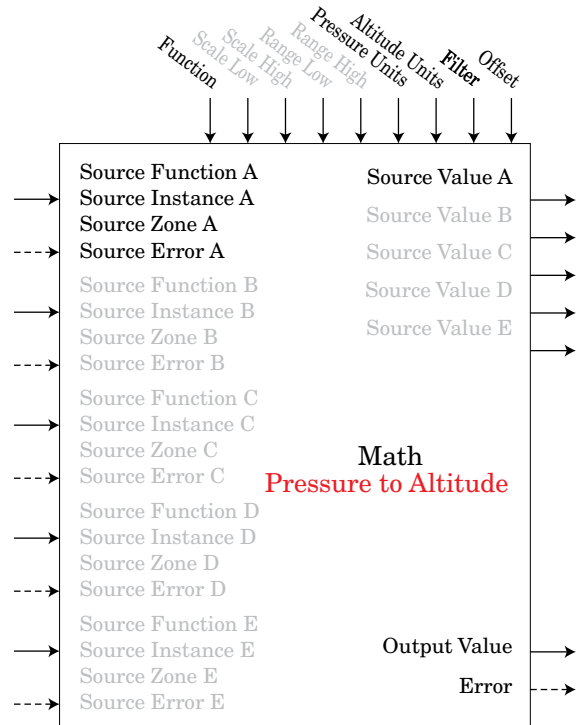

Output Value = Filter [Convert Source A in Pressure to Altitude + Offset]

Note: Pressure Altitude calculation is based on the International Standard Atmosphere 1976. Source A is a pressure signal and needs to be in PSI units for the calculation. The calculation is accurate from sea level to 90,000 feet. It can be used beyond this range in both directions, but with loss of accuracy. The standard is based on an altitude of 0 feet (sea level) pressure of 14.6967 PSI and a temperature of 59 degrees F. Result of calculation is in feet.

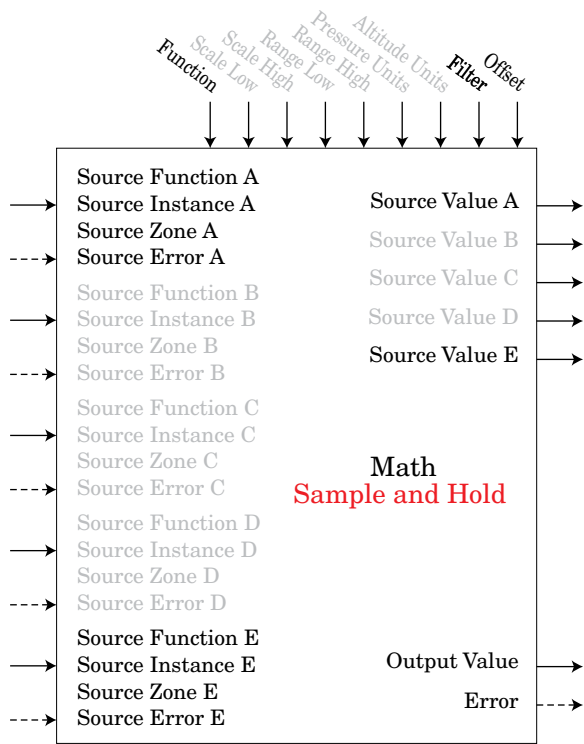

If E = OFF, Output Value = Filter [A + Offset]
 If E = ON, Output Value = Filter [last value of A + Offset]
 Display units follows Source A

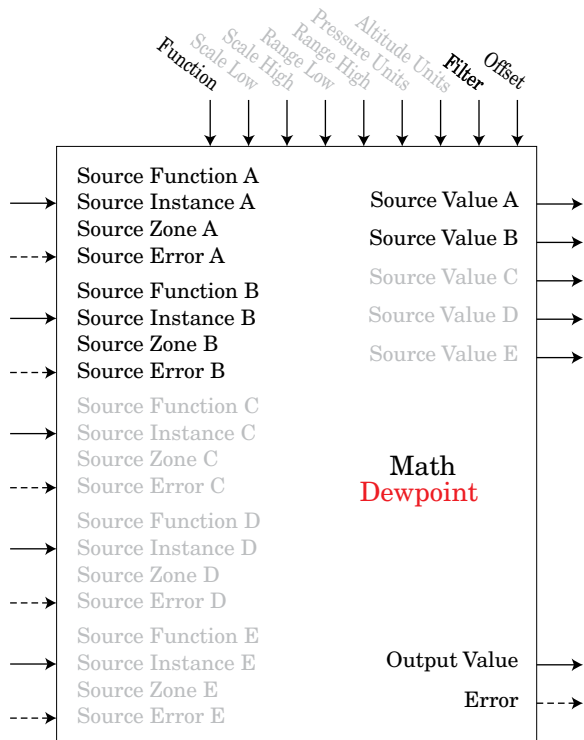

$$\text{Output Value} = \text{Filter} [427.26 * (\text{CP} * \text{B} / 8.8618) / (17.27 - (\text{CP} * \text{B} / 8.8618)) + 32 + \text{Offset}]$$

Source A is used for Calculated Pressure or CP ;

Note: For dewpoint, Source A is temperature (F) and Source B is RH (%). Saturation pressure calculation is identical to that used in wet/dry bulb. Result is in degrees F.

Output Function

This function configures and connects physical outputs to internal functions.

Note:

Digital Outputs not included on these sheets

An error, when read, can indicate any of the following:
 None, Open, Shorted, Measurement Error, Bad Cal Data, Ambient Error, RTD Error, Fail, Math Error, Not Sourced, Stale

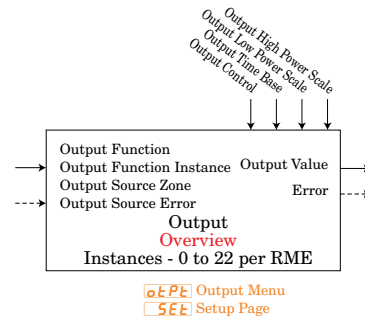

- F** Output Function : Off, Analog Input, Alarm, Cool Power, Heat Power, Compare, Counter, Digital I/O, Profile Event Out A to H, Function Key, Logic, Linearization, Math, Process Value, Special Function Output 1 to 4, Timer, Variable
- F** Output Function Instance : 1 to 24
- SZ** Output Source Zone : 0 to 16
- o.c** Output Control : Fixed Time Base, Variable Time Base
- o.t.b** Output Time Base : 0.1 to 60.0 seconds
- o.l.o** Output Low Power Scale : 0 to 100 %
- o.h.o** Output High Power Scale : 0 to 100 %
- o.t.y** Output Type: Volts or Milliamps
- F** Output Function : Off, Analog Input, Current, Cool Power, Heat Power, Control Loop Power, Linearization, Math, Process Value, Set Point Closed, Set Point Open, Special Function Outputs 1 to 4, Variable
- F** Output Function Instance : 1 to 24
- SZ** Output Source Zone : 0 to 16
- S.L.o** Scale Low: -100.0 to 100.0
- S.h.o** Scale High: -100.0 to 100.0
- r.l.o** Range Low: -1,999.000 to 9,999.000°F
- r.h.o** Range High: -1,999.000 to 9,999.000°F
- o.c.b** Calibration Offset
- o.v** Output Value : On, Off

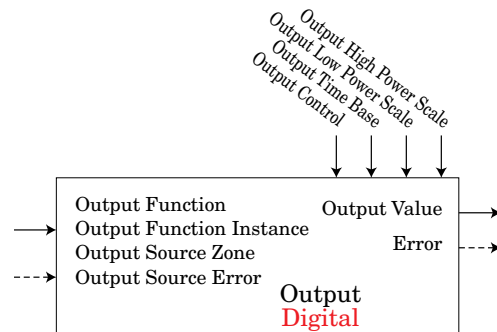
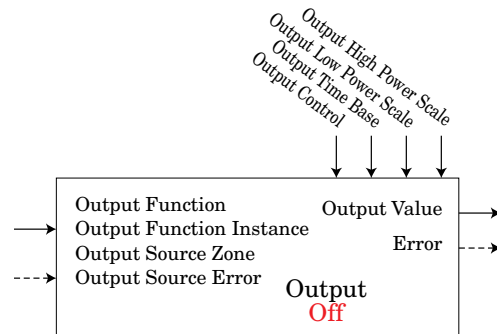

Security Function

Note:

Set on a Zone by Zone basis. This is independent of the RUI Security Setting.

If the Password is enabled, the user must enter the Password to get to menus that have been blocked due to lock level settings. Rolling passwords require a new password each time the power has been cycled to the controller. It will be different for every controller. The administrator password is required to change the security settings even if the user enters their password to override the security settings.

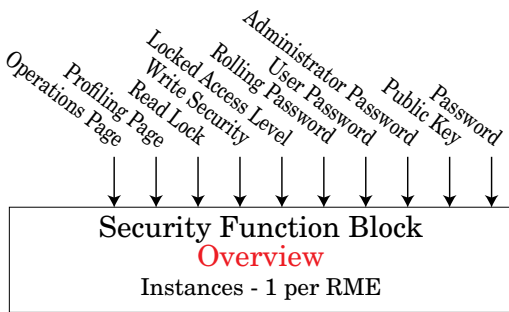

LoC Lock Menu
FRct Factory Page

- LoCo** Operations Page : 1 to 3
- LoCP** Profiling Page : 1 to 3
- PRSE** Password Enable : Off, On
- rLoC** Read Lock : 1 to 5
- SLoC** Write Security: 1 to 5
- LoCL** Locked Access Level : 1 to 5
- roLL** Rolling Password : Off, On
- PRSw** User Password : 10 to 999
- PRSA** Administrator Password : 10 to 999

ULoC Unlock Menu
FRct Factory Page

- CoDE** Public Key : xxx
- PRSS** Password : xxx

Special Output Function

This function is used to configure outputs when used with compressors, motorized valves or sequencers.

An error (1 - 4), when read, can indicate any of the following: None, Open, Shorted, Measurement Error, Bad Cal Data, Ambient Error, RTD Error, Fail, Math Error, Not Sourced, Stale

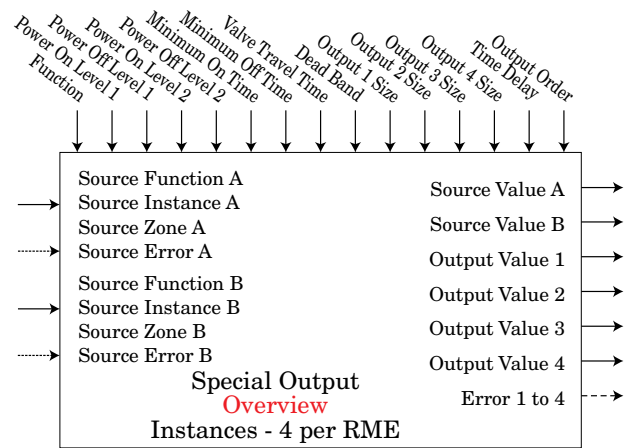

Sof Special Output Function Menu
SEt Setup Page

- Fn** Function : Off, Compressor, Motorized Valve, Sequencer
- SFnA** Source Function A : None, Analog Input, Cool Power, Heat Power, Power, Linearization, Math, Process Value, Special Function Output 1, Variable
- SIa** Source Instance A : 1 to 24
- SZA** Source Zone A : 0 to 16
- SFnB** Source Function B : None, Cool Power, Heat Power, Power, Linearization, Math, Variable
- SIb** Source Instance B : 1 to 24
- SZb** Source Zone B : 0 to 16
- POnA** Power On Level 1 : -100.0 to 100.0 %
- POFA** Power Off Level 1 : -100.0 to 100.0 %
- POnB** Power On Level 2 : -100.0 to 100.0 %
- POFB** Power Off Level 2 : -100.0 to 100.0 %
- ont** Minimum On Time : 0 to 9,999 seconds
- off** Minimum Off Time : 0 to 9,999 seconds
- tT** Valve Travel Time : 10 to 9,999 seconds
- db** Dead Band : 1.0 to 100.0 %
- o51** Output 1 Size : 0 to 9,999
- o52** Output 2 Size : 0 to 9,999
- o53** Output 3 Size : 0 to 9,999
- o54** Output 4 Size : 0 to 9,999
- t.dL** Time Delay : 0 to 9,999 seconds
- oLo** Output Order : Linear, Progressive

Sof Special Output Function Menu
oPEr Operation Page

- SuA** Source Value A : -1,999.000 to 9,999.000
- SuB** Source Value B : -1,999.000 to 9,999.000
- ou1** Output Value 1 : -1,999.000 to 9,999.000 %
- ou2** Output Value 2 : -1,999.000 to 9,999.000 %
- ou3** Output Value 3 : -1,999.000 to 9,999.000 %
- ou4** Output Value 4 : -1,999.000 to 9,999.000 %

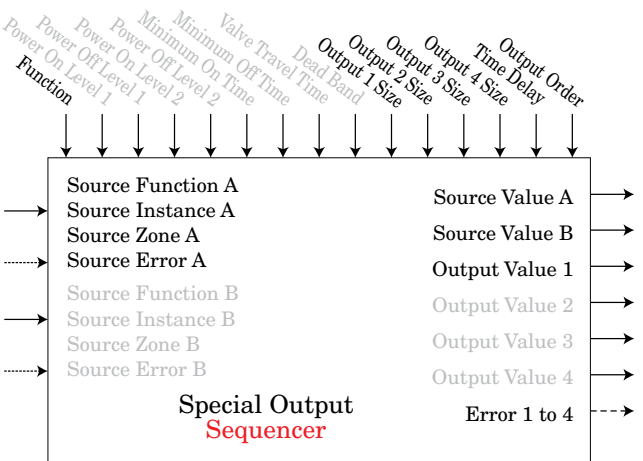
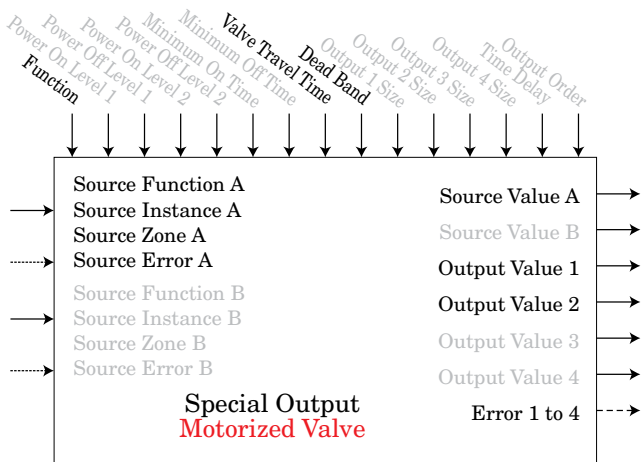
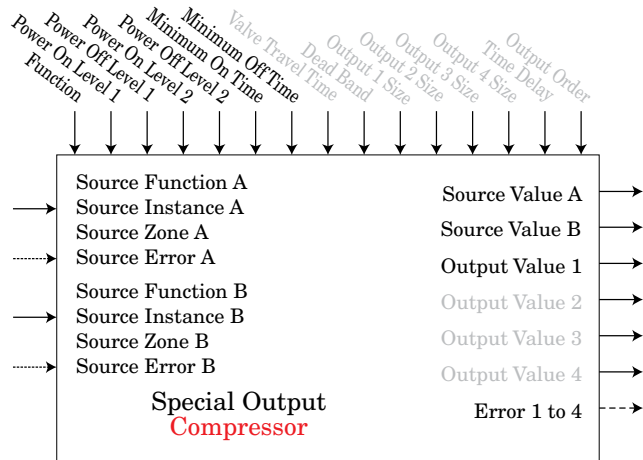
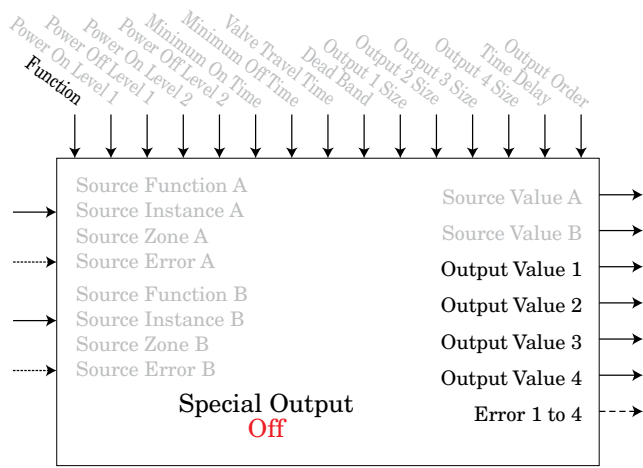

Timer Function

An error, when read, can indicate any of the following:
None, Open, Shorted, Measurement Error, Bad Cal Data, Ambient Error, RTD Error, Fail, Math Error, Not Sourced, Stale

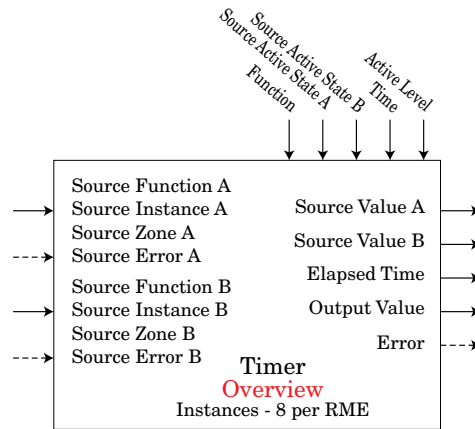

[E n] Timer Menu
[S E E] Setup Page

- [F n]** Function : Off, On Pulse, Delay, One Shot, Retentive
- [S F n A]** Source Function A (Timer Run) : None, Alarm, Compare, Counter, Digital I/O, Profile Event Out A to H, Function Key, Logic, Special Function Output 1 to 4, Timer, Variable
- [S I A]** Source Instance A : 1 to 24
- [S Z A]** Source Zone A : 0 to 16
- [S A S A]** Source Active State A (Timer Run): High (rising), Low (falling)
- [S F n b]** Source Function B (Timer Reset) : None, Alarm, Compare, Counter, Digital I/O, Profile Event Out A to H, Function Key, Logic, Special Function Output 1 to 4, Timer, Variable
- [S I b]** Source Instance B : 1 to 24
- [S Z b]** Source Zone B : 0 to 16
- [S A S b]** Source Active State B (Timer Reset): High (rising), Low (falling)
- [T t]** Time : 0 to 9,999 seconds
- [L E w]** Active Level : High, Low

[E n] Timer Menu
[O P E r] Operation Page

- [S v A]** Source Value A : Off, On
- [S v b]** Source Value B : Off, On
- [E t]** Elapsed Time : 0.0 to 9,999.000 seconds
- [o v]** Output Value : Off, On

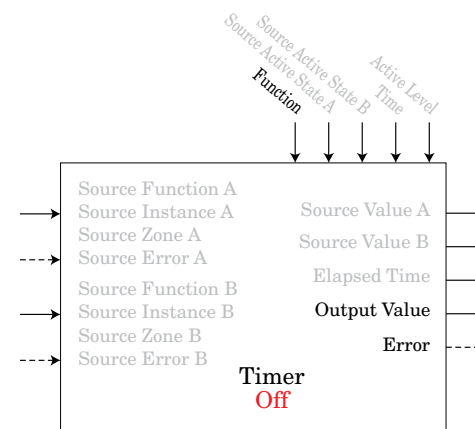

Output Value = OFF

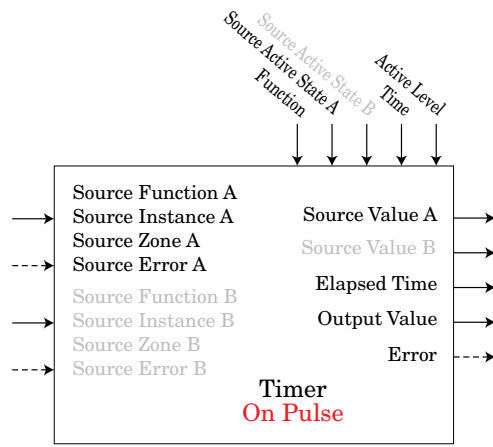

An On Pulse Timer is used to produce an output pulse of a constant duration. It can be used as a minimum on time for compressor control or other devices that do not want excessive cycling.

Timing Diagram of On Pulse with active state rising edge

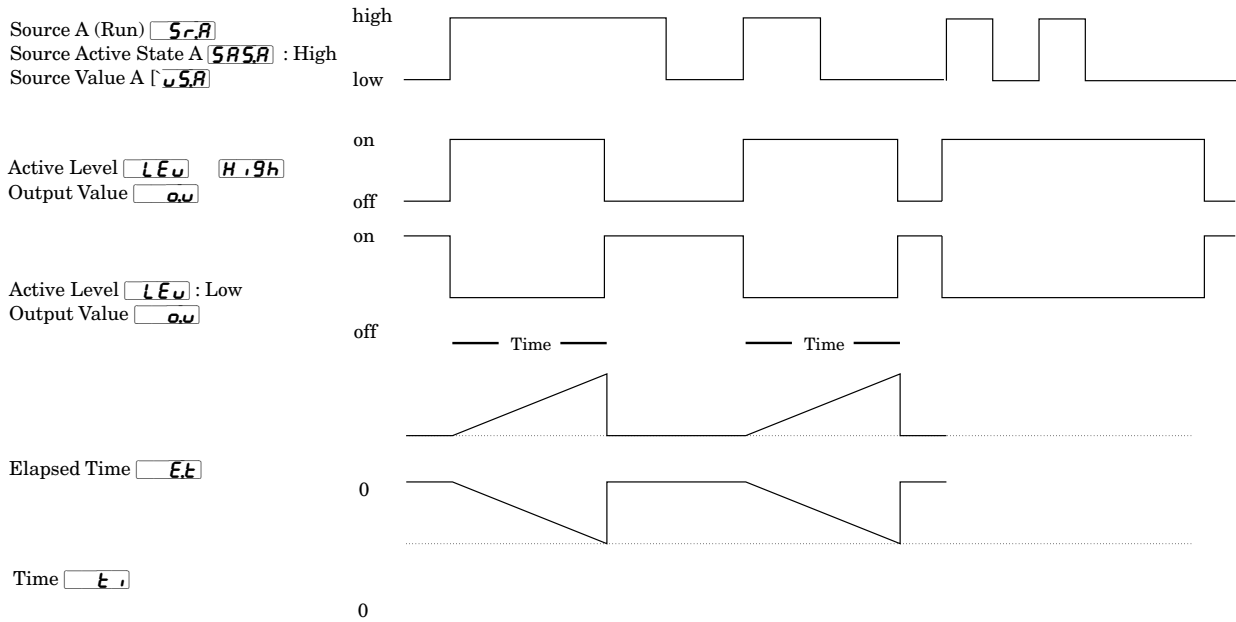

Timing Diagram of On Pulse with active state falling edge

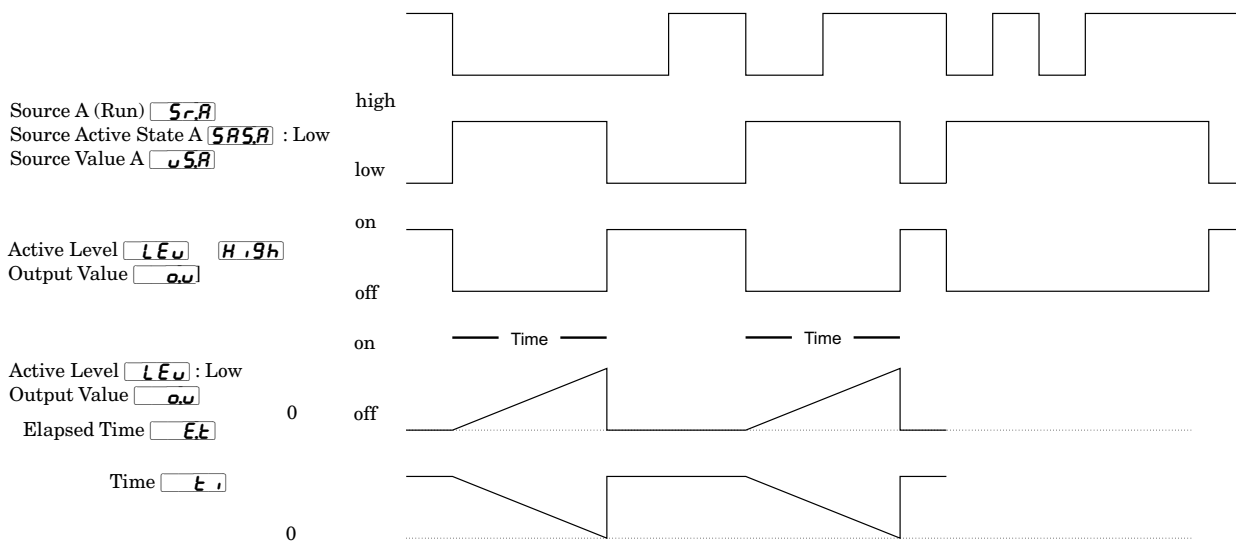

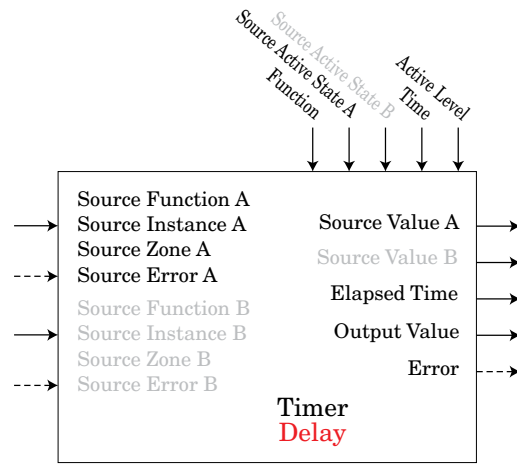

A delay timer is used to cause a delaying action. The delay can be made to happen on either the leading or trailing edge. This can be used to keep short input pulses from propagating or to have a secondary action occur at a known amount of time after the primary action; such as, turning on successive output devices.

Source A

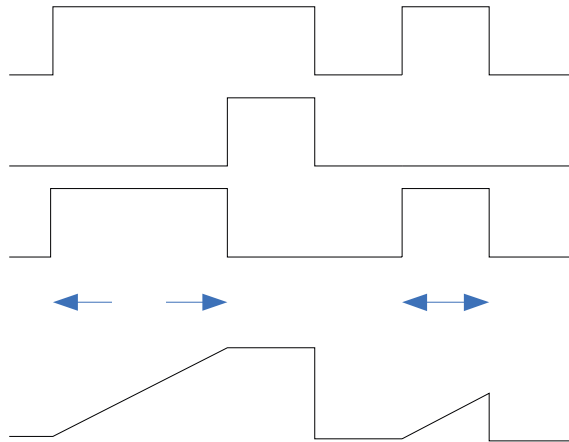

Source A

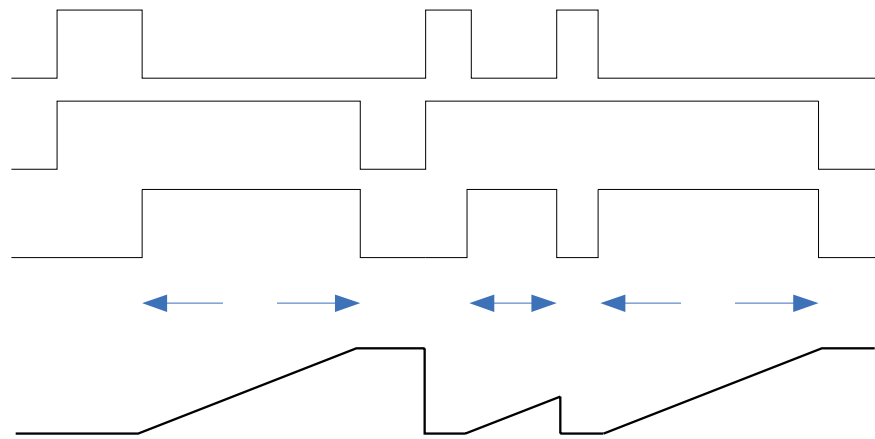

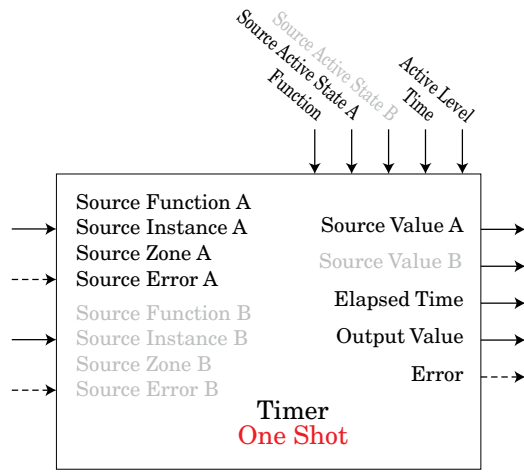

The One Shot timer functions like a simple oven timer. The time value gets set by the user and it counts down to zero without retaining the original time (hence the name one-shot). This is intended to be used in applications where the user will manually set different times for each process.

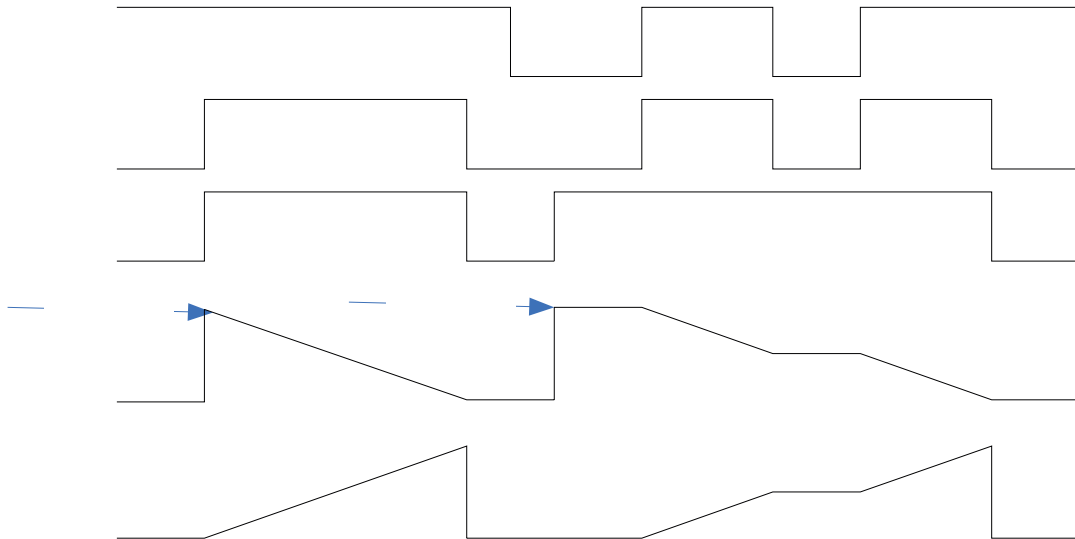

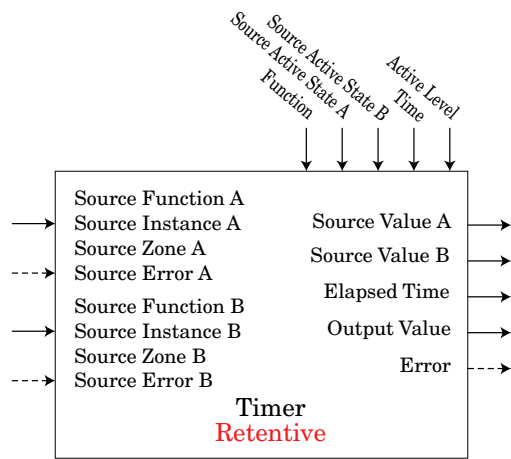

A retentive timer is used to keep track of how much time something has been in a particular state. This can be used to time how long something has been in an alarm state for example or how long it has been since a profile or step ran. The output can be used to trigger an event if the elapsed time has grown excessive.

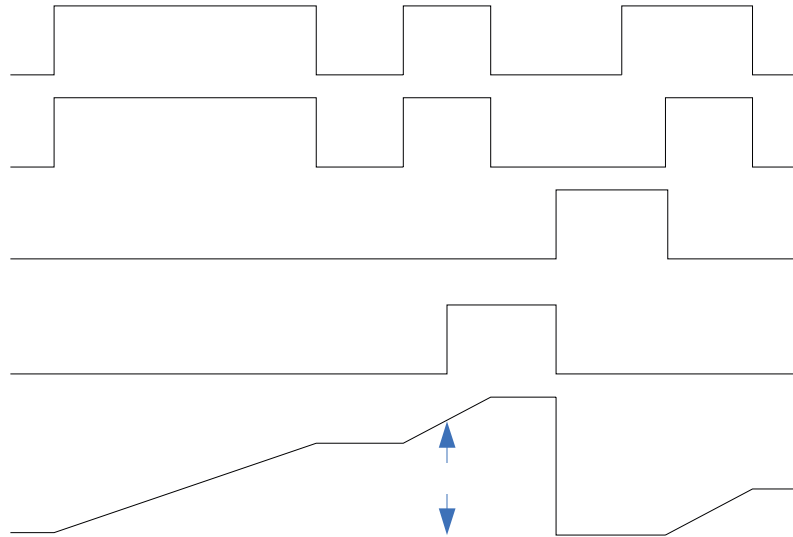

Variable Function

This function simply passes the stored value to its output.

An error, when read, can indicate any of the following: None, Open, Shorted, Measurement Error, Bad Cal Data, Ambient Error, RTD Error, Fail, Math Error, Not Sourced, Stale

A variable function block is used to store a user supplied value and provide a source input to another function block with that value. As an example, you could use a variable function value as one input to a compare function. The other input to the compare function would determine the output value based on the user's supplied value.

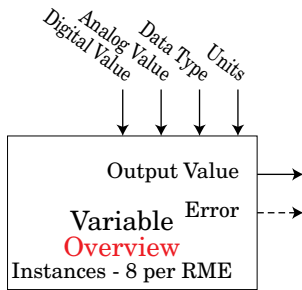

VAR Variable Menu
SET Setup Page

TYPE	Data Type : Analog, Digital
d, g	Digital Value : On, Off
RnL g	Analog Value : -1,999.000 to 9,999.000
Un, tE	Units : None, Absolute Temperature, Relative Temperature, Power, Process, Relative Humidity
ow	Output Value : -1,999.000 to 9,999.000 or On, Off

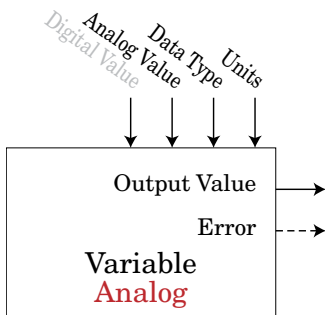
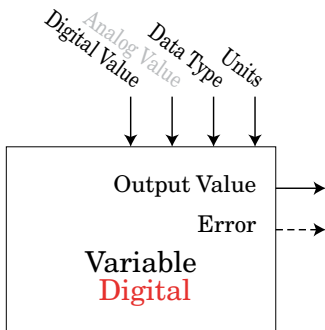

Chapter 7: Appendix

RME Specifications

Line Voltage/Power

- 20.4 to 30.8V \approx (ac/dc), 50/60Hz, \pm 5 percent
- Power consumption: 7 W, 14VA
- Any external power supply used should comply with a class 2 or SELV rating. (See specific module specification listing for maximum VA power consumption)
- Data retention upon power failure via nonvolatile memory
- Compliant with Semi F47-0200, Figure R1-1 voltage sag requirements

Environment

- 0 to 149°F (-18 to 65°C) operating temperature
- -40 to 185°F (-40 to 85°C) storage temperature
- 0 to 90 percent RH, non-condensing
- Rail Mount modules are considered to be open type equipment needing to be installed in a fire and shock protection enclosure, such as a NEMA Type 1 enclosure; unless all circuit connections are Class 2 or SELV (Safety Extra Low Voltage)

Agency Certifications

- UL[®]/EN 61010 listed; c-UL C22.2 #61010 File E185611 QUYYX, QUYY7
- ANSI/ISA 12.12.01-2007 Hazardous Locations Class 1, Div. 2-Group A, B, C, D Temperature code T4 (optional) File E184390 QUZW, QUZW7
- EN 60529 IP20; RM modules
- UL[®] 50, Type 4X indoor use, EN 60529 IP66; 1/16 DIN RUI, NEMA 4X
- RoHS by design, W.E.E.E.
- CE

Serial Communications

- The RME module ships with the isolated Standard Bus protocol for configuration and communication connection to all other EZ-ZONE products

Maximum System Configuration

- One access module plus up to 16 additional RM modules (any combination), with up to 152 control loops

Mounting

- DIN-rail specification EN50022, 35 x 7.5 mm (1.38 x 0.30 in.)
- Can be DIN-rail mounted or chassis mounted with customer-supplied fasteners

Wiring Termination—Touch Safe Terminals

- Right angle and Front screw type terminal blocks (slots A, B, D, E)
 - Input, power and controller output terminals, touch safe removable 12 to 30 AWG
 - Wire strip length 7.6 mm (0.30 in.)
 - Torque 0.8Nm (7.0 lb.-in.) right angle, 0.5Nm (4.51 lb-in) front terminal block
- Ring lug terminal block
 - Wire strip length 7.6 mm (0.30 in.)
 - Torque 1.13Nm (10.0 lb.-in.)
- Use solid or stranded copper conductors only

Connector	Dimension "A" (mm/in.)
Standard	148 (5.80)
Straight	155 (6.10)
Ring Terminal	166 (6.50)

Digital Input

- Update rate 10Hz
- DC voltage
 - Max. input 36V at 3mA
 - Min. high state 3V at 0.25mA
 - Max. low state 2V

Dry Contact

- Update rate 10Hz
- Min. open resistance 100K Ω
- Max. closed resistance 50 Ω

Output Hardware

Digital Output

- Update rate 10Hz
- Switched DC
 - Output voltage 20V \approx (dc) or 12V \approx (dc), user selectable
 - Max. supply current source 40mA at 20V \approx (dc) and 80mA at 12V \approx (dc)
- Open Collector
 - Switched voltage max.: 32V \approx (dc)
 - Max. switched current per output: 1.5A
 - Max. switched current for all 6 outputs combined: 8A

Dual Solid-State Relays

- Dual SSR board option, Form A, 10A max. each SSRs combined @ 24V \sim (ac) min., 264V \sim (ac) max., opto-isolated, without contact suppression
 - Maximum resistive load 10 A per output @ 240V (ac)
 - Maximum 20 A per card @ 50 °C
 - Maximum 12 A per card @ 65 °C

Quad Relays

- Four electromechanical relays, Form A, 5A, 24 to 240V \sim (ac) or 30V \approx (dc) max., resistive load, 100,000 cycles at rated load. Requires a min. load of 20mA at 24V, 120/240 V \sim (ac) 125VA, 24V \sim (ac) 25VA pilot duty

Process/Retransmit Outputs, Range Selectable

- - 0 to 10V \approx (dc) into a min. 4K Ω load
- - 0 to 20mA into max. 400 Ω load

Resolution

- dc ranges: 0.2mV nominal
- mA ranges: 0.4 μ A nominal

Calibration Accuracy

- dc ranges: \pm 15 mV
- mA ranges: \pm 30 μ A

Temperature Stability

- 100 ppm FSR/°C

Quad Solid-State Relays

- 2 A at 20 to 264V \sim (ac) maximum resistive load
- 50 VA 120/240V \sim (ac) pilot duty

Programmable Application Blocks

Actions (events) 8 total

Alarms 8 total

Compare 8 total

Off, greater than, less than, equal, not equal, greater than or equal, less than or equal

Counters 8 total

Counts up or down, loads predetermined value on load signal.
Output is active when count value equals predetermined target value.

Logic 8 total

Off, and, nand, or, nor, equal, not equal, latch

Linearization 8 total

Interpolated or stepped relationship

Math 8 total

Off, average, process scale, deviation scale, differential (subtraction), ratio (divide), add, multiply, absolute difference, minimum, maximum, square root, sample and hold

Special Output Function 8 total

Compressor turns on-off compressor for one or two loops (cool and dehumidify with single compressor)

Motorized Valve turns on-off motor open/closed outputs to cause valve to represent desired power level

Sequencer turns on-off up to four outputs to distribute a single power across all outputs with linear and progressive load wearing

Timers 8 total

On Pulse produces output of fixed time on active edge of timer run signal

Delay output is a delayed start of timer run, off at same time

One Shot oven timer

Retentive measures timer run signal, output on when accumulated time exceeds target

Variable 8 total

User value for digital or analog variable

Optional Accessories

Remote User Interface

Basic RUI

- 1/16 DIN
- Dual 4 digit, 7-segment LED displays
- Keys: Advance, infinity, up, down keys, plus a programmable function key (EZ-KEY)
- Typical display update rate 1Hz

Power Supplies

- AC/DC Power supply converter 90-264V~ (ac) to 24V= (dc) volts.
- P/N 0847-0299-0000: 31 W
- P/N 0847-0300-0000: 60 W
- P/N 0847-0301-0000: 91 W

EZ-ZONE RM Product Documentation

- User's Guide, printed hard copy, P/N 0600-0073-0000
- Watlow Support Tools CD, P/N 0601-0001-0000

EZ-ZONE Rail-Mount Expansion Module Ordering Information

Expansion module requires a Class 2 or SELV power supply 20.4 to 30.8 V \approx (ac / dc), communication port for configuration with EZ-ZONE Configurator software.

Code Number

①② EZ-ZONE Rail Mount	③ Expansion Module	④ Connector Style/ Custom Product	⑤ Slot A	⑥ Slot B	⑦ Slot D	⑧ Slot E	⑨⑩ Future Options	⑪⑫ Additional Options
RM	E						AA	

④ Connector Style/Custom product
<p>A = Right angle screw connector (standard) F = Front screw connector R = Ring lug connector (If ordered, then slots B and E must be = A) S = Custom</p>

⑤ Slot A
<p>A = None C = 6 Digital I/O J = 4 Mechanical relay 5A, Form A F = 3 Universal Process/Retransmit outputs L = 4 SSR's at 2 amps each K = 2 SSRs, Form A, 10A max. each (If ordered, then slots B must be = A)</p>

⑥ Slot B
<p>A = None C = 6 Digital I/O F = 3 Universal Process/Retransmit outputs L = 4 SSR's at 2 amps each J = 4 Mechanical relay 5A, Form A</p>

⑦ Slot D
<p>A = None J = 4 Mechanical relay 5A, Form A C = 6 Digital I/O F = 3 Universal Process/Retransmit outputs L = 4 SSR's at 2 amps each K = 2 SSRs, Form A, 10A max. each (If ordered, then slot E must be = A)</p>

⑧ Slot E
<p>A = None C = 6 Digital I/O F = 3 Universal Process/Retransmit outputs L = 4 SSR's at 2 amps each T = Quad current transformer inputs</p>

⑨⑩ Future Options
AA = Standard

⑪⑫ Additional Options
<p>Firmware, Overlays, Parameter Settings AA = Standard AB = Replacement connectors hardware only, for the entered model number 12 = Class 1, Div. 2 (not available with integrated limit controller or mechanical relay options) XX = Custom</p>



Watlow®, EZ-ZONE® and TRU-TUNE® are registered trademarks of Watlow Electric Manufacturing Company.
 UL® is a registered trademark of Underwriter's Laboratories, Inc.
 Modbus® is a registered trademark of Schneider Automation Incorporated.
 DeviceNet™ and EtherNet/IP™ are trademarks of Open DeviceNet Vendors Association.

Index

- A**
 - ABL** Alarm Blocking 48, 83
 - ACLF** AC Line Frequency 74
 - ACLR** Clear Request 29
 - ACT** Action Menu 30, 41
 - ADSP** Alarm Display 48
 - AH** Alarm High Set Point 30, 47, 82
 - AHY** Alarm Hysteresis 47
 - AS** Alarm Source Instance 47, 49
 - ALR** Alarm Latching 48, 82
 - ALG** Alarm Logic 47
 - ALM** Alarm Menu 30, 46
 - ALO** Alarm Low Set Point 30, 47, 82
 - ASD** Alarm Sides 47
 - AS** Alarm Silencing 48, 82
 - ASR** Alarm Silence Request 48
 - SR** Silence Request 29
 - ASE** Alarm State 48
 - SE** State 29
 - ATTN** Attention 82
 - ATY** Alarm Type 46
 - AUNIT** Altitude Units 39, 70
 - CF** Display Units 74
 - CODE** Public Key 78
 - CPE** Compare Menu 32, 51
 - CTR** Counter Menu 33, 55
 - CUSE** Custom Setup Menu 76
 - DATE** Date of Manufacture 78
 - DEWJ** Dewpoint 66
 - DAG** Diagnostics Menu 78
 - DO** Digital Input/Output Menu 30, 40
 - DIR** Direction 40
 - DO5** Digital Output State 30
 - DPRS** Display Pairs 39, 74
 - EIS** Event Input Status 30
 - F** Digital Output Function Instance 41
 - F** Output Function Instance 43, 44, 46
 - Fn** Output Function 43, 45
 - GLBL** Global Menu 74
 - IPFY** IP Fixed Address Part 4 74
 - LRE** Latching 39
 - LGC** Logic Menu 33, 57
 - LNR** Linearization Menu 31, 48
 - LOC** Security Setting Menu 76, 78
 - LOCL** Locked Access Level 77
 - LOCO** Lock Operations Page 76, 83
 - LOCP** Lock Profiling Page 76, 77, 78, 83
 - PIA** Milliamps 44
 - PMATH** Math Menu 34, 66
 - OCR** Calibration Offset 46
- B**
 - Blocking 48
- C**
 - Calibration Offset 46
 - Cascade Control 81
 - CIP - Communications Capabilities 86
 - Compare Menu 32, 51
 - connecting and wiring the modules 26
 - Control 41, 44
 - control methods 80
 - Control Module Menus
 - Factory Page
 - Security Setting Menu 78
 - Counter Menu 33, 55
 - current measurement 110
 - current sensing 83
 - Current Sensing 83
 - Custom Setup Menu 76
- D**
 - Date of Manufacture 78
 - Dewpoint 66
 - Diagnostics Menu 78
 - Digital Input/Output Menu 30, 40
 - digital input specifications 110
 - Dimensions 11
 - dimensions 10–11
 - Direction 40
 - Display 48
 - Display Pairs 39, 74
 - Display Units 74
 - duplex 80
 - Duplex Control 81
- E**
 - environment 110
 - Expansion Module Menus
 - Factory Page
 - Custom Setup Menu 76
 - Diagnostics Menu 78
 - Security Setting Menu 76
 - Operations Page
 - Action Menu 30
 - Alarm Menu 30
 - Compare Menu 32
 - Counter Menu 33
 - Digital Input/Output Menu 30
 - Linearization Menu 31
 - Logic Menu 33
 - Math Menu 34
 - Special Output Function Menu 35
 - Timer Menu 32
 - Setup Page
 - Action Menu 41
 - Alarm Menu 46
- A**
 - AC Line Frequency 74, 80
 - Action Menu 30, 41
 - Administrator Password 78
 - Agency Certifications 4
 - alarm blocking 83
 - Alarm Menu 30, 46
 - alarms 81
 - Blocking 48, 83
 - Display 48
 - Hysteresis 47, 82
 - Latching 48, 82
 - Logic 47
 - process 82
 - set points 82
 - Sides 47
 - Silencing 48, 82
 - Source 47
 - Type 46
 - Altitude Units 39, 70
 - Appendix 110
 - OC** Output Control 41, 44
 - OH** Output High Power Scale 41, 44
 - OLA** Output Low Power Scale 41, 44
 - OTB** Output Time Base 41, 44
 - OTPE** Output Menu 43
 - OTY** Output Type 44
 - PASP** Administrator Password 78
 - PASE** Password Enable 76
 - PASS** Password 78
 - PASU** User Password 77
 - Pn** Part Number 78
 - PUNIT** Pressure Units 39
 - REV** Software Revision 78
 - RH** Range High 46
 - RL** Range Low 46
 - RLCS** Read Lockout Security 77, 83
 - ROLL** Rolling Password 77
 - SBLD** Software Build 78
 - SFA** Source Function A 47
 - SH** Scale High 46
 - SL** Scale Low 46
 - SLCS** Set Lockout Security 77, 83
 - SN** Serial Number 78
 - SOF** Special Output Function Menu 35
 - TPR** Timer Menu 32, 52
 - ULCS** Unlock 75
 - UNIT** Units 69
 - USR** User Restore Set 74, 80
 - USS** User Save Set 74, 80
 - VAR** Variable Menu 74
 - VOLT** Volts 44

- Compare Menu 51
- Counter Menu 55
- Digital Input/Output Menu 40
- Global Menu 74
- Linearization Menu 48
- Logic Menu 57
- Math Menu 66
- Output Menu 43
- Special Output Function Menu 70
- Timer Menu 52
- Variable Menu 74

EZ Key 83

F

- Factory Page
 - Control Module 75
- Function Instance 41
- Function Key Menu 83

G

- Global Function 93
- Global Menu 74

H

- High Power Scale 41, 44
- high range 80
- High Set Point
 - Alarm 30, 31, 47, 48, 82
- Hysteresis 47

I

- installation 13
- Installation 13
- inputs 6
- IP Fixed Address Part 4 74
- isolation blocks 18

J

K

L

- Latching 48
- Linearization Menu 31, 48
- line voltage/power 110
- Locked Access Level 77
- Lock Operations Page 83
- Lockout Menu 83
- Lock Profiling Page 83
- Logic 47
- Logic Menu 33, 57
- Low Power Scale 41, 44
- Low Set Point
 - Alarm 30, 47, 82

M

- Math Menu 34, 66
- Modbus - Using Programmable Memory Blocks 86
- Motorized Valve Control 81

N

- network wiring 27
- No-arc Relay 80

O

- Operations Page
 - Control Module 29
- operator interface 110
- Output Function 45
- Output Menu 43
- outputs 6
- Output State 30
- Output Type 44

P

- Parameter 1 to 20 76
- Part Number 78
- Password 75, 78
- Peltier Delay 39
- power supplies 12
- Power Supplies 12
- Pressure Units 39
- process alarms 82
- programming the Home Page 80
- Public Key 75, 78

Q

- Quencharc 22

R

- Range High 46, 80
- Range Low 46
- Read Lockout Security 83
- restoring user settings 80
- retransmit 81
- Rolling Password 77

S

- saving user settings 80
- Scale High 46
- Scale Low 46
- secure settings 83, 84
- Security Setting 78
- Security Setting Menu 76
- serial communications 110
- Serial Number 78
- Set Lockout Security 83
- Setup Page
 - Control Module 38
- Sides
 - Alarm 47
- Silencing 48
- single set point ramping 81
- Software Build 78
- Software Configuration 86
- Software Revision 78
- Source 47
- Special Output Function Menu 35, 70

- Specifications 110
- standard connector, all modules 17
- System Security 84

T

- Ten Point Linearization 80
- terminal function
 - Expansion Module 15, 16
- Time Base 41, 44
- Timer Function 104
- Timer Menu 32, 52
- tuning the PID parameters 80
- Type 46

U

- USB converter 25
- User Password 77
- User Restore Set 74, 80
- User Save Set 74, 80
- Using EZ-ZONE® Configurator Software 86
- using the software 83

V

- Variable Menu 74
- variable time base 80

W

- wiring
 - input 2 potentiometer 19
 - wiring a network 26, 27
 - wiring a serial EIA-485 network 27
 - wiring, Controller Module
 - current transformer input 1 to 4 19
 - wiring, Expansion Module 19
 - digital inputs/outputs 1 through 24 19
 - dual solid-state relay output 1 to 4 22
 - QUAD mechanical relays, form A Outputs 1 to 4, 7 to 10, 13 to 16 21
 - wiring termination, touch-safe terminals 110

X

Y

Z

Declaration of Conformity

EZ Zone Series RM



WATLOW
1241 Bundy Blvd.
Winona, MN 55987 USA

an ISO 9001 approved facility since 1996.

Declares that the following Series RM (Rail Mount) products:

Model Numbers: **RM** followed by additional letters or numbers describing use of up to four module options of various inputs and outputs or communications.
Classification: Temperature control, Installation Category II, Pollution degree 2
Voltage and Frequency: SELV 24 to 28 V~ ac 50/60 Hz or dc
Power Consumption: RMA models 4 Watts, any other RM model 7 Watts
Environmental Rating: IP20

Meet the essential requirements of the following European Union Directives by using the relevant standards show below to indicate compliance.

2004/108/EC Electromagnetic Compatibility Directive

EN 61326-1	2006		Electrical equipment for measurement, control and laboratory use – EMC requirements, Industrial Immunity, Class A Emissions (Not for use in a Class B environment without additional filtering).
EN 61000-4-2	1996	A1, A2, 2001	Electrostatic Discharge Immunity
EN 61000-4-3	2006		Radiated Field Immunity
EN 61000-4-4	2004		Electrical Fast-Transient / Burst Immunity
EN 61000-4-5	2006		Surge Immunity
EN 61000-4-6	1996	A1, A2, A3, 2005	Conducted Immunity
EN 61000-4-11	2004		Voltage Dips, Short Interruptions and Voltage Variations Immunity
EN 61000-3-2	2005		Harmonic Current Emissions
EN 61000-3-3 ²	2005		Voltage Fluctuations and Flicker
SEMI F47	2000		Specification for Semiconductor Sag Immunity Figure R1-1

²NOTE 1: To comply with flicker requirements cycle time may need to be up to 160 seconds if load current is at 15A, or the maximum source impedance needs to be < 0.13Ω. Control power input of RM models comply with 61000-3-3 requirements.

2006/95/EC Low-Voltage Directive

EN 61010-1	2001	Safety Requirements of electrical equipment for measurement, control and laboratory use. Part 1: General requirements
-------------------	-------------	--

Compliant with 2002/95/EC RoHS Directive

Per 2002/96/EC W.E.E.E Directive  Please Recycle Properly

Raymond D. Feller III
Name of Authorized Representative

Winona, Minnesota, USA
Place of Issue

March 2010
Date of Issue

General Manager

Title of Authorized Representative

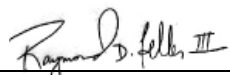
Signature of Authorized Representative

How to Reach Us

Corporate Headquarters

Watlow Electric Manufacturing Company
12001 Lackland Road
St. Louis, MO 63146
Sales: 1-800-WATLOW2
Manufacturing Support: 1-800-4WATLOW
Email: info@watlow.com
Website: www.watlow.com
From outside the USA and Canada:
Tel: +1 (314) 878-4600
Fax: +1 (314) 878-6814

Latin America

Watlow de México S.A. de C.V.
Av. Fundación No. 5
Col. Parques Industriales
Querétaro, Qro. CP-76130
Mexico
Tel: +52 442 217-6235
Fax: +52 442 217-6403

Europe

Watlow France
Tour d'Asnières.
4 Avenue Laurent Cély
92600 Asnières sur Seine
France
Tél: + 33 (0)1 41 32 79 70
Télécopie: + 33(0)1 47 33 36 57
Email: info@watlow.fr
Website: www.watlow.fr

Watlow GmbH
Postfach 11 65, Lauchwasenstr. 1
D-76709 Kronau
Germany
Tel: +49 (0) 7253 9400-0
Fax: +49 (0) 7253 9400-900
Email: info@watlow.de
Website: www.watlow.de

Watlow Italy S.r.l.
Viale Italia 52/54
20094 Corsico MI
Italy
Tel: +39 024588841
Fax: +39 0245869954
Email: italyinfo@watlow.com
Website: www.watlow.it

Watlow Ibérica, S.L.U.
C/Marte 12, Posterior, Local 9
E-28850 Torrejón de Ardoz
Madrid - Spain
T. +34 91 675 12 92
F. +34 91 648 73 80
Email: info@watlow.es
Website: www.watlow.es

Watlow UK Ltd.
Linby Industrial Estate
Linby, Nottingham, NG15 8AA
United Kingdom
Telephone: (0) 115 964 0777
Fax: (0) 115 964 0071
Email: info@watlow.co.uk
Website: www.watlow.co.uk
From outside The United Kingdom:
Tel: +44 115 964 0777
Fax: +44 115 964 0071

Asia and Pacific

Watlow Singapore Pte Ltd.
16 Ayer Rajah Crescent,
#06-03/04,
Singapore 139965
Tel: +65 6773 9488 Fax: +65 6778 0323
Email: info@watlow.com.sg Website: www.watlow.com.sg

Watlow Australia Pty., Ltd.
4/57 Sharps Road
Tullamarine, VIC 3043
Australia
Tel: +61 3 9335 6449
Fax: +61 3 9330 3566
Website: www.watlow.com

Watlow Electric Manufacturing Company (Shanghai) Co. Ltd.
Room 501, Building 10, KIC Plaza
290 Songhu Road, Yangpu District
Shanghai, China 200433
China
Phone
Local: 4006 Watlow (4006 928569)
International: +86 21 3381 0188
Fax: +86 21 6106 1423
Email: info@watlow.cn
Website: www.watlow.cn

ワトロー・ジャパン株式会社
〒101-0047 東京都千代田区内神田1-14-4
四国ビル別館9階
Tel: 03-3518-6630 Fax: 03-3518-6632
Email: infoj@watlow.com Website: www.watlow.co.jp

Watlow Japan Ltd.
1-14-4 Uchikanda, Chiyoda-Ku
Tokyo 101-0047
Japan
Tel: +81-3-3518-6630 Fax: +81-3-3518-6632
Email: infoj@watlow.com Website: www.watlow.co.jp

Watlow Korea Co., Ltd.
#1406, E&C Dream Tower, 46, Yangpyeongdong-3ga
Yeongdeungpo-gu, Seoul 150-103
Republic of Korea
Tel: +82 (2) 2628-5770 Fax: +82 (2) 2628-5771
Website: www.watlow.co.kr

Watlow Malaysia Sdn Bhd
1F-17, IOI Business Park
No.1, Persiaran Puchong Jaya Selatan
Bandar Puchong Jaya
47100 Puchong, Selangor D.E.
Malaysia
Tel: +60 3 8076 8745 Fax: +60 3 8076 7186
Email: vlee@watlow.com
Website: www.watlow.com

瓦特龍電機股份有限公司
80143 高雄市前金區七賢二路189號 10樓之一
電話: 07-2885168 傳真: 07-2885568

Watlow Electric Taiwan Corporation
10F-1 No.189 Chi-Shen 2nd Road Kaohsiung 80143
Taiwan
Tel: +886-7-2885168 Fax: +886-7-2885568

Your Authorized Watlow Distributor

