

FEATURES

- Wide flow range
- One moving part
- Hot tap available
- Modular electronics compatible
- Easily depth adjustable for 3-40" pipe

APPLICATIONS

- Clean water
- Large pipes
- Aquariums, water parks
- Water & wastewater monitoring

GENERAL INFORMATION

The TX100/200-Series are adjustable depth insertion turbines that come in brass or 316 stainless models to fit 3" to 40" pipe. Installation fittings are standard 1-1/2" (101/201) or 2" (115/215) FNPT. Fittings such as saddles and weldolets may be purchased either locally or from Seametrics.

Ruby bearings and a non-drag pickoff give these adjustable insertion turbine flow sensors a wide flow range and long life. A sensor detects the passage of miniature magnets in the rotor blades. The resulting square-wave signal can be sent for hundreds of feet without a transmitter, over unshielded cable. This signal can be connected directly to many PLC's and other controls without any additional electronics.

If desired, a modular system of electronics can be installed directly on the flow sensor or mounted remotely. The FT415 (battery powered) or FT420 (loop powered) provides digital rate and total display, as well as programmable pulse; the FT420 also provides a 4-20 mA analog output. The A055 is a blind analog (4-20 mA) transmitter. Programmable pulse for pump pacing is available with the PD10.

The "hot-tap" models (TX115/215) can be installed or serviced without shutting down the line by means of a 2" full-port isolation valve that comes with a nipple for installation on the pipe fitting. In most circumstances, no special tool is required.

FEATURES

Modular electronics (optional)

- rate/total/pulse/4-20 mA
- blind 4-20 transmitter
- pulse divider

18 Foot Cable

Rugged cast aluminum housing

Compression nut
for easy adjustment, secure locking

Adapter fitting
with 1-1/2" NPT threads

Rotor housing

Removable jewel bearings
Rotor

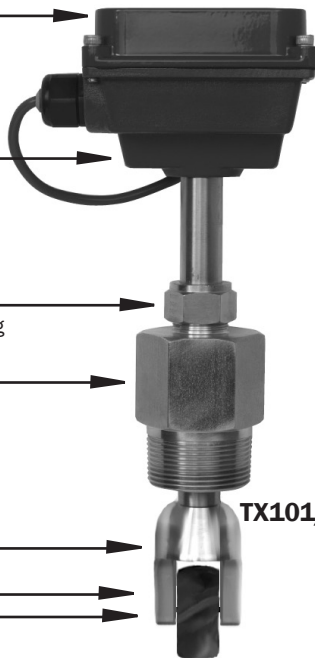

TX101/201

3/4" diameter tubing
for low insertion force

2" Adapter

removes to mount
hot-tap machine
Full-port 2" ball valve
for sensor removal

Adapter fitting
with 2" NPT threads

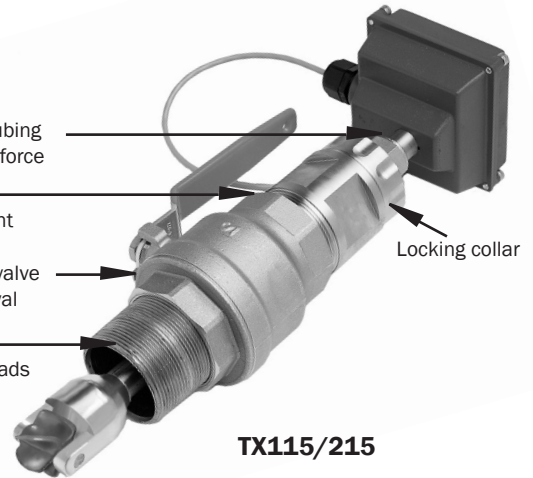

TX115/215

SPECIFICATIONS*

Power Source		Standard	Micropowered (-04 Option)
Supply Voltage/Current		6-40 Vdc/< 2 mA	3.5-16 Vdc/60 µA @ 3.5 Vdc
Sensor	Type	Magneto-resistive	Magneto-resistive
	Output	Current Sinking Pulse	Current Sinking Pulse
	Sinking Current	100 mA max	2 mA max
	External Pull-up Resistor	3-40 Vdc	≤ Supply Voltage
Pipe Size		TX101/115 3" - 12" (50 - 300mm)	TX201/215 12" - 40" (300 - 1000mm)
Materials	Housing	Cast aluminum	
	Sensor Body	Brass or 316 SS	
	Rotor	PVDF standard	
	Shaft/Bearings	Nickel-bound tungsten carbide/Ruby	
	Isolation Valve	TX101/201 None	TX115/215 Bronze (316SS optional)
Fitting Size		1-1/2" NPT	2" NPT
Flow Range		0.5 - 30 feet/sec (0.15 - 9.14 meter/sec)	
Accuracy		+/-1.5% of full scale	
Maximum Temperature		200° F (93° C)	
Maximum Pressure		200 psi (14 bar)	
Insertion Force		0.44 x pressure in pipe	
Cable		#22 AWG 3-con, 18' (6m); 2,000' (650m) maximum cable run	
Regulatory		CE Mark (Standard Power Only)	

*Specifications subject to change. Please consult our website for the most current data (www.seametrics.com).

DIMENSIONS

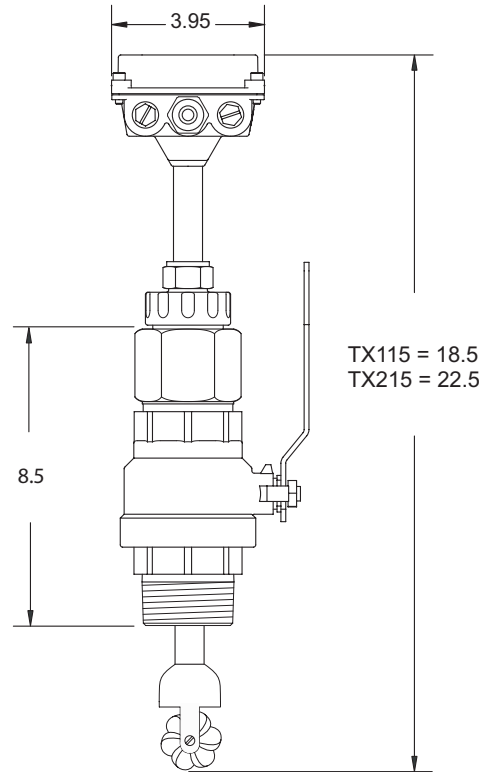
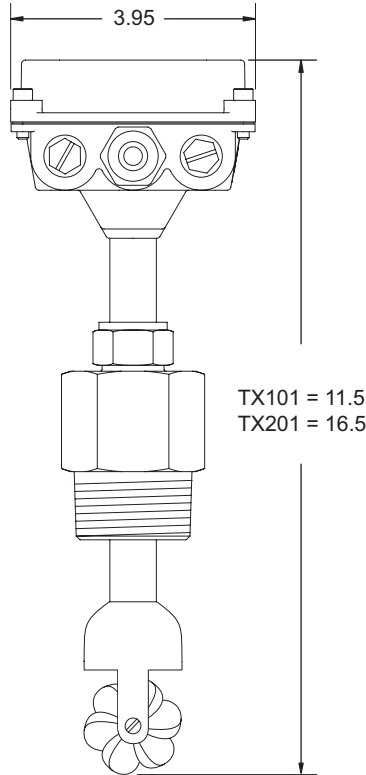

HOT TAP INSTALLATION

Insertion and removal under pressure is possible due to the 2" full-port isolation valve, which comes with a nipple for installation on the pipe fitting. If it is necessary to do the initial installation under pressure, any standard hot tap drilling machine with 2" NPT adapter, such as a Transmate or a Mueller, can be used. Ordinarily, it is not necessary to use an installation tool, since the small-diameter tube can be controlled by hand at all but the highest pressures.

HOT TAP REMOVAL

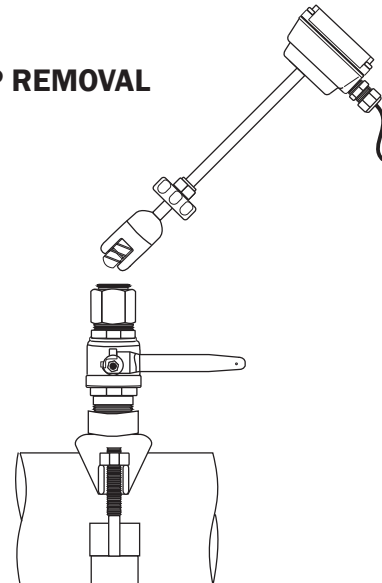

FLOW RANGE (Gallons Per Minute)

Pipe Size	3"	4"	6"	8"	10"	12"	16"	18"	24"	30"	36"	40"
Min.	11.5	19.8	45	78	123	176	313	396	704	1,100	1,585	1,960
Max.	691	1,190	2,700	4,680	7,370	10,470	16,520	20,900	37,600	62,505	87,410	117,500

Approximations based on Schedule 40 pipe.



TX100/200-SERIES Insertion Turbine Flow Sensor

HOW TO ORDER

MODEL

3" - 12" = **TX101**
3" - 12" Hot tap = **TX115**
12" - 40" = **TX201**
12" - 40" Hot tap = **TX215**

MATERIAL

Brass = **B**
316 Stainless = **S**

OPTIONS

Adapter Fitting, 2" Threads = **-02**
Bi-Directional = **-03**
Micropower Pickup (FT415 & DL76 Only) = **-04**
LMI Pump Connector = **-06**
Seametrics Control Connector = **-07**
Stainless Valve Assembly (115/215 only) = **-08**
No Valve Assembly (115/215 only) = **-09**
*Immersibility = **-40**
12" Extension (200-Series only) = **-72**

*Consult factory for suitable applications

ACCESSORIES

Rate & Total Indicator w/4-20 mA Output = **FT420**
Battery Operated Rate/Totalizer = **FT415**
Blind 4-20 mA Transmitter = **AO55**
Power Supply = **PC3**

Data Logger = **DL76**
Pulse Divider = **PD10**
Saddle Fittings = **Consult Factory**

CONTACT YOUR SUPPLIER