

RDO® Optical Dissolved Oxygen Sensor



RDO is a registered trademark of In-Situ Inc. All rights reserved.

CAUTION
SENSOR/PROCESS
APPLICATION COMPATIBILITY

The wetted sensor materials may not be compatible with process composition and operating conditions. Application compatibility is entirely the responsibility of the user.

RDO PROBE SPECIFICATIONS

Wetted Materials: Delrin¹, ABS, Viton², titanium, polycarbonate/poly(methyl methacrylate) blend

Dimensions: length 8.0 in (203 mm) diameter 1.9 in (47 mm)

Rating: IP-67 with cap off; IP-68 with cap installed

Process connection: 1-1/4 inch FNPT

Integral cable length: 32 ft (10 m)

Maximum cable length (quick disconnect cable only): 4000 ft (1219 m)

Pressure: up to 314 psig (2060 kPa abs)

Temperature: 32 to 122°F (0 - 50°C)

Range: 0 to 20 ppm (mg/L) or 0 to 200% saturation

Accuracy: ±0.1 ppm between 0 and 8 ppm; ±0.2 ppm between 8 and 20 ppm

Resolution: 0.01 ppm (mg/L)

Digital output: Modbus/RS485

Response time: 30 sec to 90% of final value; 37 sec to 95% of final value (at 25°C)

Operating life of sensing cap: 1 year from first reading

Shelf life of sensing cap: 2 years from date of manufacture; for full operating life install the sensing cap within one year of manufacture date.

Safety directive: 73/23/EEC

EU directives: 2004/108/EC for Electromagnetic Compatibility (EMC) and 72/23/EEC for Safety



Immunity: EN 61000-6-2, Electromagnetic Compatibility (EMC) part 6-2

Emissions: Class A requirements of CISPR 11:2004

¹ Delrin is a registered trademark of DuPont DeNemours, LLC
² Viton is a registered trademark of DuPont Dow Elastomers, LLC

ASSEMBLING THE PROBE

1. Unscrew the nose cone from the probe and remove the red protective dust cap. Save the dust cap for later use. Make sure the O-ring grooves are dry and the O-rings are not rolled or pinched.



2. Remove the RDO sensing cap from its shipping/storage sleeve. The operating lifetime of the cap is one year after the first reading has been taken. Install the cap by the date printed on the packaging.

NOTE Keep the cap in its sealed packaging until you are ready to install it. Install promptly. Avoid allowing moisture, including humidity, inside the cap.



3. Align the arrow on the cap with the index mark on the probe and firmly press the cap onto the probe, without twisting, until it seals.
4. Reattach the nose cone.

INSTALLING THE PROBE

The RDO dissolved oxygen probe can be submerged in basins or ponds. The nose cone and the thermistor – the small metal disc on the side of the sensor about 1/8 inch (3 mm) above the nose cone – must be completely submerged. Use the 1 1/4 inch FNPT fitting at the rear of the probe to attach it to a pipe. Be sure the connection is watertight and the upper end of pipe is closed to keep out water. **Do not allow the back end of the sensor to get wet.**

WIRING

The table summarizes color and wire functions.

Color	Function
Black	Ground/return
Red	External power
Brown	4 – 20 mA
Green	RS485 -
Blue	RS485 +
White	SDI-12

For wiring the RDO probe to the RDO analyzer see the RDO Optical Dissolved Oxygen Analyzer and Sensor manual, Section 2.6 and Figure 2-3.

For wiring directly to a controller or data logger, see the Figures 1 through 4.

The red wire provides power in all system modes. Analog output is disabled by default. However, the 4-20 mA current loop output can be continuous in Modbus or SDI-12 mode as long as Modbus device register 49507 is set to 1.

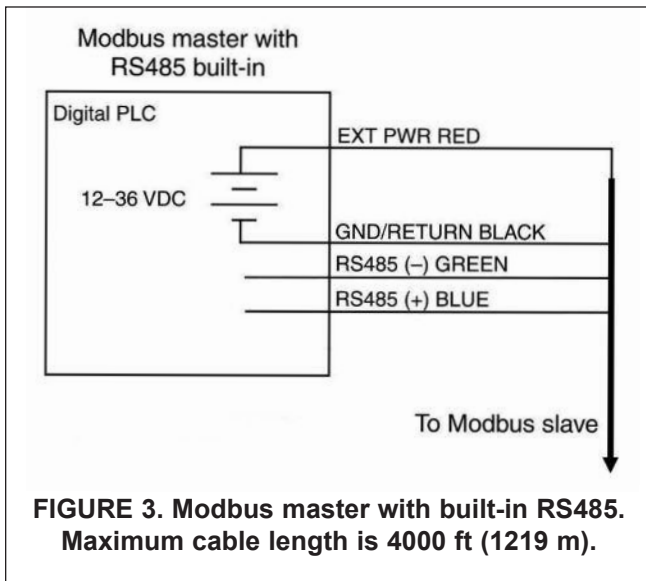
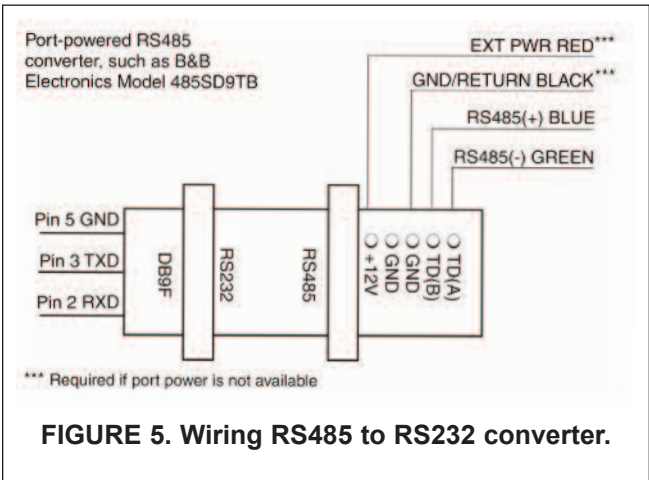
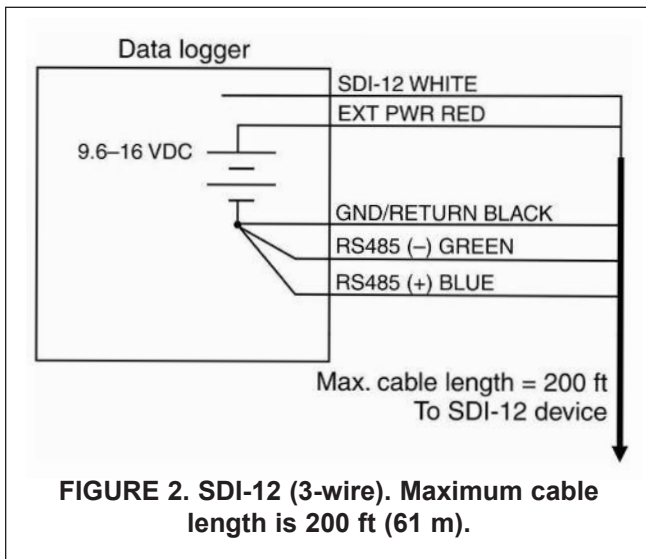
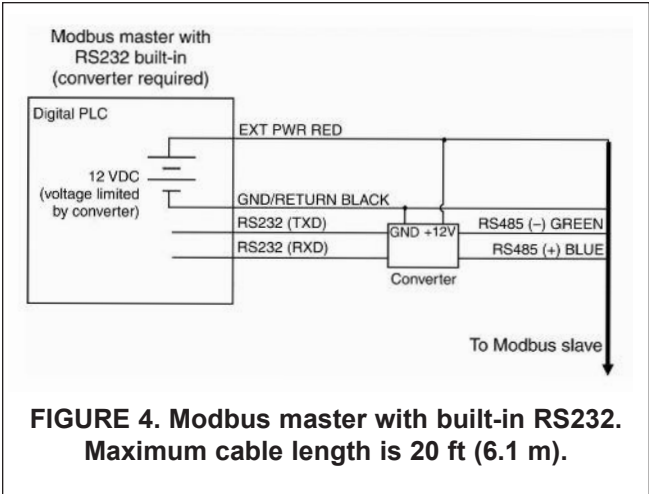
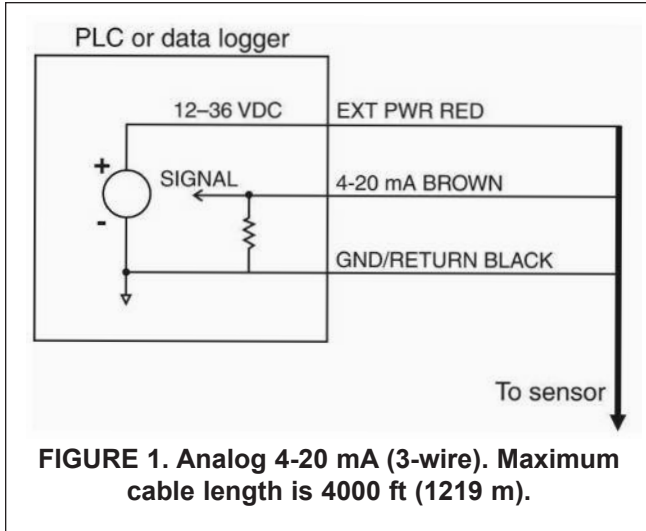

The device automatically switches between Modbus and SDI-12 modes depending on which of the two interfaces has activity. Modbus and SDI-12 cannot be used at the same time. Whichever one is currently in use will block communication on the other.

MAINTENANCE

Cleaning the sensing cap

1. Leave the sensing cap and nose cone attached to the probe body. Do not remove the sensing cap to clean it.
2. Rinse the cap with clean water from a squirt bottle.
3. If biofouling is present, gently wipe the cap with a soft-bristled brush or a soft cloth. If oil or grease is present, wash with a gentle detergent.
4. If extensive fouling or mineral build-up is present, soak the cap end of the sensor—do not remove the sensing cap—in vinegar for 15 min., then soak in deionized water for 15 min. Do not use organic solvents.

MODEL RDO PROBE

- After cleaning the sensor, check the calibration in air. Perform a one- or two-point saturation calibration if necessary.

Cleaning the probe body

- Leave the sensing cap and nose cone attached to the probe body while cleaning it. Do not remove the sensing cap.
- Gently scrub the probe body with a soft-bristled brush or a nylon dish scrubber. Use a mild detergent to remove oil or grease. Soak in vinegar followed by deionized water to remove mineral deposits or extensive fouling. See step 4, above.

Cleaning the optical window

Clean the optical window only when the sensing cap is replaced.

Replacing the sensing cap.

- The replacement sensing cap kit (PN R0084230) contains a sensing cap, two O-rings, O-ring lubricant, and a lens wipe.

NOTE: Keep the cap in its sealed packaging until you are ready to install it. Install promptly. Avoid allowing moisture, including humidity, inside the cap.

- Remove the sensor from the process liquid. Rinse with water and dry the probe body and nose cone.
- Unscrew the nose cone.
- Pull the sensing cap straight off the probe body. Do not twist.
- Remove and discard the existing O-rings.
- Remove any moisture in the O-ring grooves. Be careful not to touch the lens.
- Use your finger to apply a thin layer of lubricant around the O-ring grooves. **Be careful not to get grease on the lens or on the sensor pins.**

- Slide the two O-rings onto grooves. Check that the O-rings are not twisted or pinched. Apply a thin layer of lubricant over the O-rings and grooves. **Be careful not to get grease on the lens or on the sensor pins.**
- Clean the lens with the wipe provided in the kit, and allow it to dry thoroughly. Inspect the lens for scratches or dirt.
- Remove the new sensing cap from its sealed packaging. Align the arrow on the cap with the index mark on the probe and firmly press the cap onto the probe, without twisting, until it seals. Replace the nose cone.
- Perform a one- or two-point saturation calibration.

Storing the probe

Store the probe in the calibration chamber using the storage cap (cap without notch). Place a few drops of water in the chamber before inserting the probe.

CALIBRATION

The probe can be calibrated in two ways: saturation or concentration. Saturation refers to calibration in water-saturated air (one-point calibration) or in water-saturated air followed by oxygen-free water (two-point calibration). For more information about one- and two-point calibration, refer to the RDO Optical Dissolved Oxygen Analyzer and Sensor manual. The probe can also be calibrated against a referee instrument (concentration calibration).

Although a new probe can be used as received from the factory, it is recommended that a two-point saturation calibration be done when the probe is first put in service.

If you are using the RDO analyzer, refer to the RDO Optical Dissolved Oxygen Analyzer and Sensor manual for calibration instructions. If you have connected the RDO sensor directly to a controller or data logger, see the instructions below.

One-point Saturation Calibration (100% Saturation)

- Remove storage cap from top of calibration chamber and replace it with the calibration cap (cap with the vent hole).



REPLACEMENT PARTS

Part number	Description
R0086460	RDO sensor with 32 ft (10 m) of integral cable
R0082490	RDO sensor with twist lock connector
R00CBL10	Twist lock connector cable, 32 ft (10 m)
R00CBL20	Twist lock connector cable, 64 ft (20 m)
R00CBL30	Twist lock connector cable, 96 ft (30 m)
R0084230	RDO sensor cap replacement kit
R0080810	RDO O-ring replacement kit
R0080820	RDO replacement nose cone kit
R0088890	RDO replacement calibration cup

MODEL RDO PROBE

2. Fill the calibration chamber to the lower fill line with approximately 10 mL water. The water temperature should be as close to the sample temperature as possible.



3. Remove the sensor from the process liquid. If the sensor is fouled or dirty, clean it following the procedure in the maintenance section. Gently dry the probe and sensing foil with a soft cloth, making sure there is no water on the body of the sensor or on the sensing foil. **The sensing foil must remain dry during 100% saturation calibration.**
4. Place the probe in the calibration chamber keeping the sensing foil about 1 inch (25 mm) above the surface of the water.
5. Allow at least 5 minutes for the temperature to stabilize before starting the calibration. Keeping the sensor in the shade will help reduce drift caused by the sun's heat. Do not leave the sensor the calibration chamber for more than 30 minutes, lest condensation form on the surface of the foil, leading to false low readings after calibration. If condensation does occur, remove the probe and dry the foil. Return the sensor to the calibration chamber and continue.
6. To continue the calibration using Modbus, refer to **CALIBRATION REGISTERS** and **ENTERING CALIBRATION REGISTERS BELOW**.

Two-point saturation calibration (100% and 0% saturation)

1. Perform a 100% calibration as described above.
2. Remove the probe from the calibration chamber and fill the chamber to the upper fill line with



approximately 60 mL of fresh sodium sulfite solution. A teaspoonful of sodium sulfite in a cup of water is adequate.

3. Place the probe in the sodium sulfite solution. Be sure the thermistor thermowell (the small metallic disc about 1/8 inch (3 mm) above the nose cone) is completely submerged. Leave at least 1/2 inch (12 mm) between the surface of the foil and the bottom of the chamber. Do not allow the sensing foil to rest on the bottom of the calibration chamber. Allow at least 5 min for readings to stabilize.
4. To continue the calibration using Modbus, refer to **CALIBRATION REGISTERS** and **ENTERING CALIBRATION REGISTERS** on next page.

Live Salinity Value

The live salinity value is used to correct the oxygen concentration value for salinity. Values must be written in Practical Salinity Units (PSU) in the range 0 to 42 PSU. This is not a measured parameter.

Default Salinity Value

The default salinity value is loaded into the live salinity value register when power is first applied to the probe. The default salinity value is used in calculations until a live salinity value is written. This is not a measured parameter.

Live Barometric Pressure

The live barometric pressure is used in the calculation of percent saturation and to determine the theoretical saturation point during calibration. Values must be written in millibars in the range 506.625 to 1114.675 mbar. This is not a measured parameter.

Default Barometric Pressure

The default barometric pressure is loaded into the live barometric pressure register when power is applied to the probe. The default barometric pressure is used in calculations until a live barometric pressure is written. This is not a measured parameter.

100% Saturation Calibration Values

These values represent the sensor conditions while the probe is in a 100% saturation calibration environment. These are not measured values, they are written by the controller during the calibration process.

Writes to these registers are only accepted if the probe is in the calibration mode. The probe will return exception 0x85 (invalid device command sequence) if an attempt is made to write these registers when the calibration mode is off.

0% Saturation Calibration Values

These values represent the sensor conditions while the probe is in a 0% saturation calibration environment. These are not measured values, they are written by the controller during the calibration process.

CALIBRATION REGISTERS

Register	Size (registers)	Mode & Access Level (R/W)	Data Type	Description
40118	2	R1/W3	float	Live salinity value (PSU)
40120	2	R1/W3	float	Default salinity value (PSU, default = 0.0)
40122	2	R1/W3	float	Live barometric pressure (mbar)
40124	2	R1/W3	float	Default barometric pressure (mbar, default = 1013.25)
40126	2	R1/W3	float	100% saturation calibration reading (mg/L)
40128	2	R1/W3	float	100% saturation temperature reading (°C)
40130	2	R1/W3	float	100% saturation salinity value (PSU)
40132	2	R1/W3	float	100% saturation barometric pressure (mbar)
40134	2	R1/W3	float	0% saturation calibration reading (mg/L)
40136	2	R1/W3	float	0% saturation temperature reading (°C)
40138	2	R1/W3	float	Calibration slope (default = 1.0)
40140	2	R1/W3	float	Calibration offset (default = 0.0)

Writes to these registers are only accepted if the probe is in the calibration mode. The probe will return exception 0x85 (invalid device command sequence) if an attempt is made to write these registers when the calibration mode is off.

Calibration Slope and Offset

These values represent the slope and offset that will be applied to the raw concentration reading from the sensor to generate the final values reported by the sensor parameters. These registers may be written independently of the normal internal calibration procedure.

ENTERING CALIBRATION REGISTERS

The sensor is calibrated using the following procedure:

- Optional:** Read the Sensor Data Cache Timeout register 49463 and store the value.
- Write the Sensor Data Cache Timeout register 49463 to a value less than your intended sample rate and greater than 1000 milliseconds. This will ensure that you get new sensor readings during the stabilization process.
- Optional:** Read the temperature units register 40049 and saturation units register 40041 and store their values.
- Write the temperature units register 40049 to its default value (1) and write the saturation units register 40041 to its default value (117).
- Write the Calibration Mode On command (0xE000) to the sensor command register 49305.
- Update the live salinity and barometric pressure registers if necessary.
- Prompt the user to place the probe in a 100% saturation environment.
- Read the oxygen concentration and temperature parameters. When these values have reached equilibrium, record them in their respective 100% saturation calibration registers. Write the current live salinity and barometric pressure readings to their respective calibration registers.
- Prompt the user to place the sensor in a 0% saturation environment. When these registers have reached equilibrium, record them in their respective 0% saturation calibration registers. If a zero calibration is not to be performed, these registers can be set to zero or left at their previous values. **Note: If you have a version of RDO firmware that is earlier than 1.15 and you are not doing the zero calibration, you must set the 0% calibration registers to zero.**
- Write the Calibration Update command (0xE001) to the sensor command register. The sensor will calculate a new slope and offset, write the current time to the last user calibration time register, and set the next user calibration time register to zero (disabled). If the concentrations at 100% and 0% saturation are equal, the probe will return an exception response with code 0x97 (invalid calibration) and not attempt to compute a new slope and offset due to possible division by zero. If the slope does not calculate between 0.85 and 1.20 inclusive, or the offset does not calculate between -0.2 and +0.2 inclusive, the probe will return an exception response with code 0x97 (invalid calibration). The slope and offset will be available for read but will not be committed to flash.
- Optional:** Read the last user calibration time register, add the next calibration interval, and write the result to the next user calibration time register.

MODEL RDO PROBE

12. Write the Calibration Mode Off command (0xE002) to the sensor command register to place the sensor in normal operation. If the calibration mode is turned off without a calibration update command or the calibration command returned an exception, the previous calibration shall be restored.
13. **Optional:** If you saved the temperature and saturation parameter units at the start of the process, write the original values back.
14. **Optional:** If you saved the Sensor Data Cache Timeout register 49463 at the start of the process, write the original value back.

DEVICE SPECIFIC MEASUREMENT REGISTERS

Register	Size (registers)	Mode & Access Level (R/W)	Data Type	Description
Dissolved Oxygen Concentration				
40038	2	R1	float	Measured value, C ₀
40040	1	R1	ushort	Parameter Id = 20
40041	1	R1/W2	ushort	Units Id 117 = mg/L (default) 118 = µg/L
40042	1	R1	ushort	Data Quality Id
40043	2	R1/W3	float	Off line sentinel value (default = 0.0)
40045	1	R1	16 bits	Available Units = 0x0030 (48)
Temperature				
40046	2	R1	float	Measured value
40048	1	R1	ushort	Parameter Id = 1
40049	1	R1/W2	ushort	Units Id 1 = C (default) 2 = F
40050	1	R1	ushort	Data Quality Id
40051	2	R1/W3	float	Off line sentinel value (default = 0.0)
40053	1	R1	16 bits	Available Units = 0x0003 (3)
Dissolved Oxygen %Saturation				
40054	2	R1	float	Measured value
40056	1	R1/W2	ushort	Parameter Id = 21
40057	1	R1/W2	ushort	Units Id 177 = percent saturation (default)
40058	1	R1	ushort	Data Quality Id
40059	2	R1/W3	float	Off line sentinel value (default = 0.0)
40061	1	R1	16 bits	Available Units = 0x0001 (1)
Oxygen Partial Pressure				
40062	2	R1	float	Measured value
40064	1	R1	ushort	Parameter Id = 2 (pressure)
40065	1	R1/W2	ushort	Units Id 26 = torr (default)
40066	1	R1	ushort	Data Quality Id
40067	2	R1/W3	float	Off line sentinel value (default = 0.0)
40069	1	R1	16 bits	Available Units = 0x0200 (512)



*The right people,
the right answers,
right now.*

**ROSEMOUNT ANALYTICAL
CUSTOMER SUPPORT CENTER
1-800-854-8257**



Credit Cards for U.S. Purchases Only.



ON-LINE ORDERING NOW AVAILABLE ON OUR WEB SITE
<http://www.raihome.com>

Specifications subject to change without notice.

Emerson Process Management

2400 Barranca Parkway
Irvine, CA 92606 USA
Tel: (949) 757-8500
Fax: (949) 474-7250
<http://www.raihome.com>

