

ENDURANCE® Conductivity Sensors

For additional information, please refer to the Instruction Manuals CD shipped with this product, or visit our website at www.emersonprocess.com/raihome/liquid/.

CAUTION
SENSOR/PROCESS
APPLICATION COMPATIBILITY

The wetted sensor materials may not be compatible with process composition and operating conditions. Application compatibility is entirely the responsibility of the user.



CAUTION



BEFORE REMOVING THE SENSOR, be absolutely certain the process pressure is reduced to 0 psig and the process temperature is at a safe level!

SENSOR SPECIFICATIONS

SPECIFICATIONS	MODEL 400	MODEL 400 VP	FLOW CELL PN 24091-02
Wetted Materials	titanium, PEEK (glass-filled), 316 SST, EPDM	titanium, PEEK (glass-filled) , 316 SST, EPDM	polycarbonate, polyester, 316 SST, silicone
Temperature Range	std: 32-221°F (0-105°C) -60: 32-392°F (0-200°C) (requires sensor-mounted junction box)	32-221°F (0-105°C)	32-122°F (0-50°C)
Maximum Pressure	250 psig (1825 kPa abs)	250 psig (1825 kPa abs)	65 psig (549 kPa abs)
Vacuum Service	7.3 psia (51 kPa abs)	7.3 psia (51 kPa abs)	

INSTALLATION

Keep 1/4 in. (0.6 cm) clearance between electrodes and piping. The electrodes must be completely submerged in the process liquid, i.e., to the level of the threaded connection. See Figures 1 - 6 for recommended orientation and installation. Models 400 and 400VP sensors with 0.1 and 1.0/cm cell constants can be installed in 3/4-inch pipe tees. All Model 400 and 400VP sensors can be installed in 1-inch tees with a 3/4-inch bushing.

If the sensor is installed in a pipe tee or flow cell with the sample draining to open atmosphere, bubbles may accumulate on the electrodes. Trapped bubbles will cause errors. As bubbles accumulate, the conductivity reading normally drifts down. In the plastic flow cell, bubbles are readily visible. To control bubble formation, apply a small amount of back pressure to the flow cell or pipe tee.

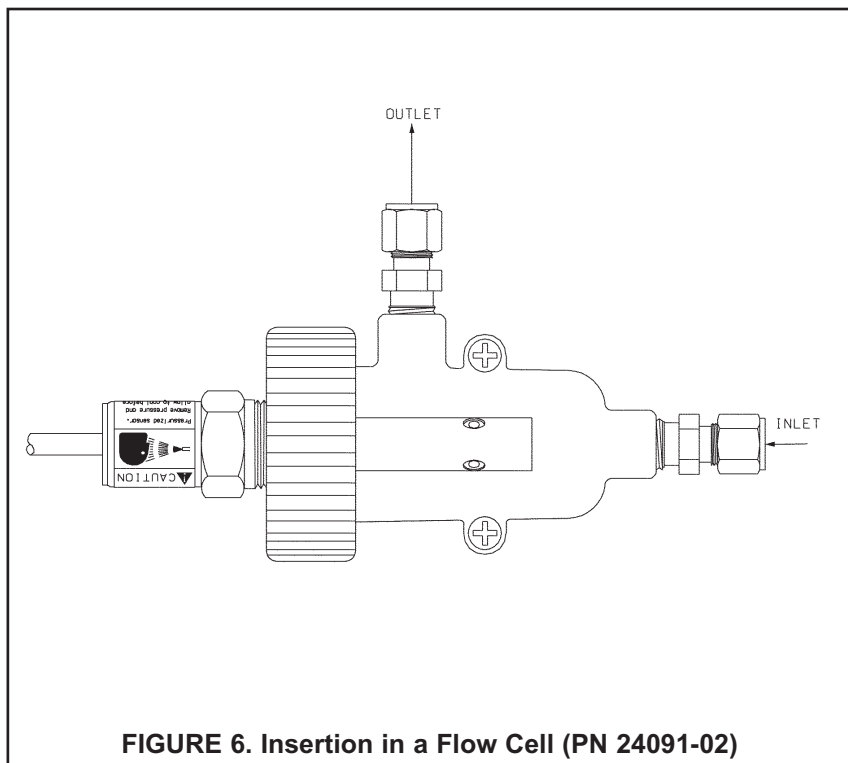
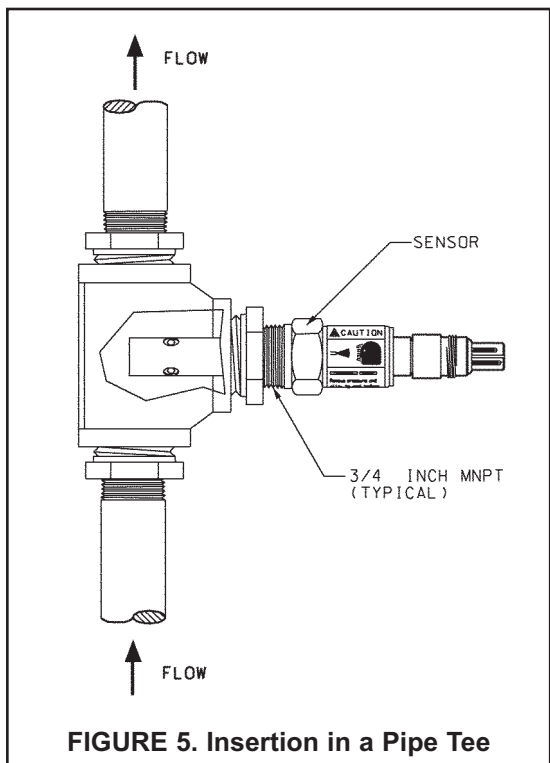
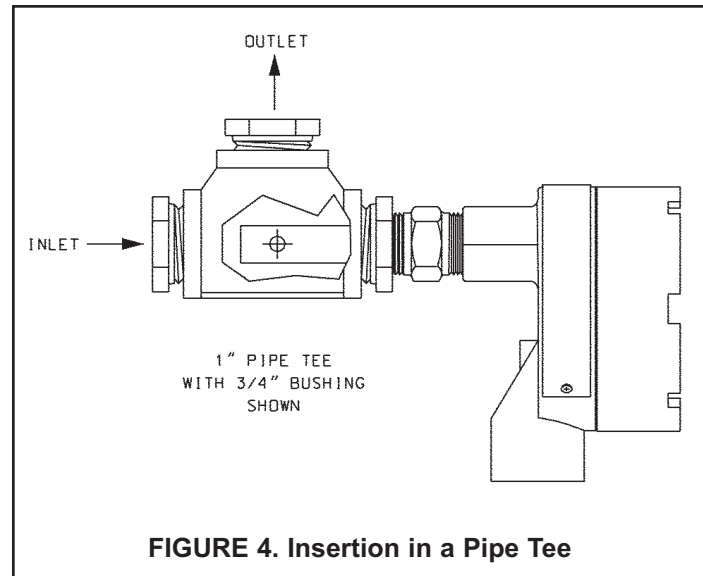
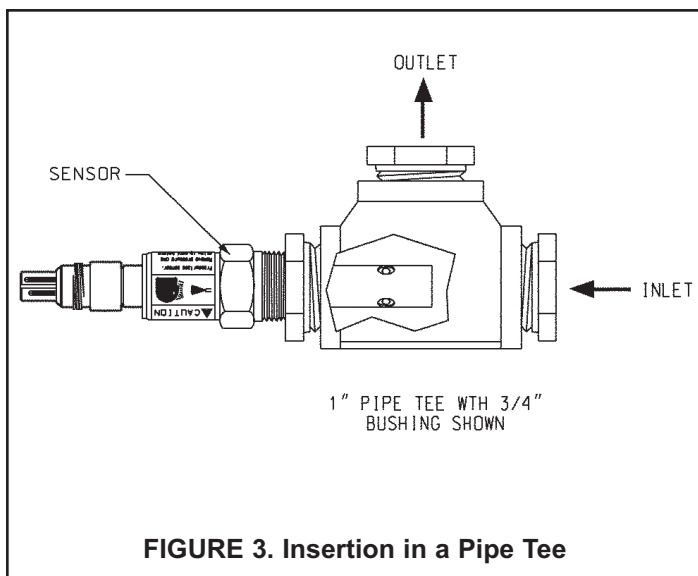
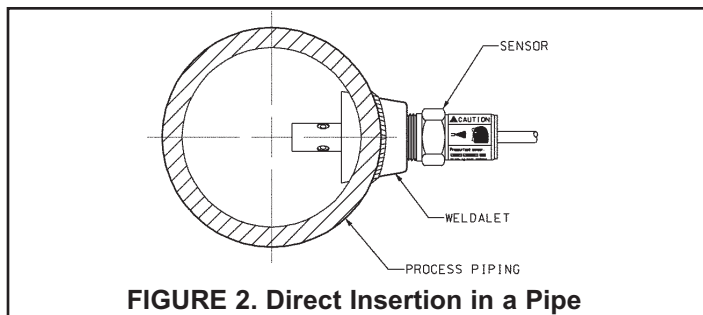
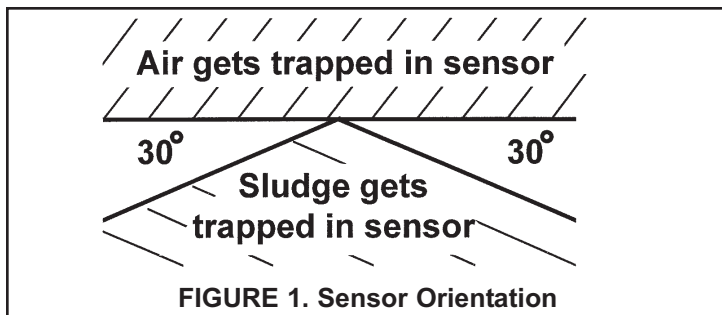

WIRING

WIRE COLOR AND FUNCTIONS

NAME	COLOR	FUNCTION
Drive	Gray	Connects to outer electrode
Drive Common	Clear	Coaxial shield for gray wire
Receive	Orange	Connects to inner electrode
Receive Common	Clear	Coaxial shield for orange wire
RTD In	Red	
RTD Sense	White with red stripe	
RTD Return	White	
RTD Shield	Clear	

For 1181C-compatible sensors, the RTD is replaced with a thermistor. The red and white wires are connected to the thermistor. The red and white striped wire is not used.

WIRING DIAGRAMS

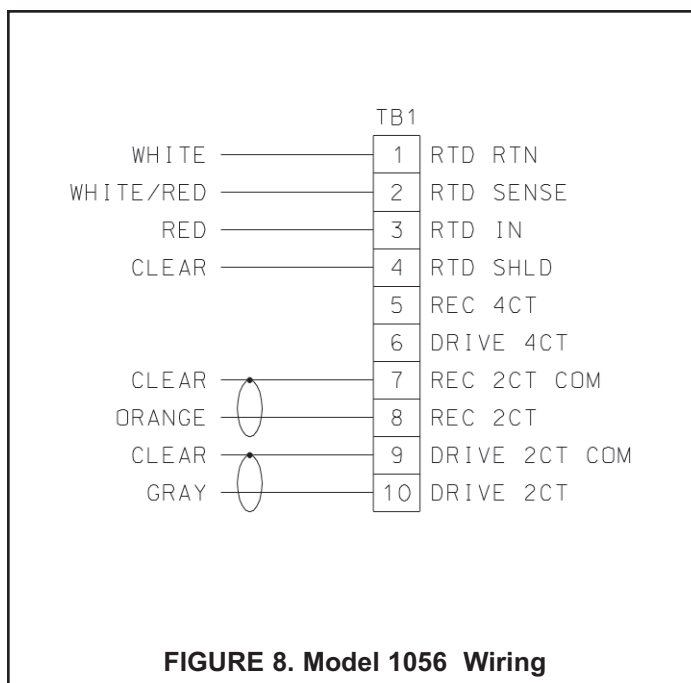
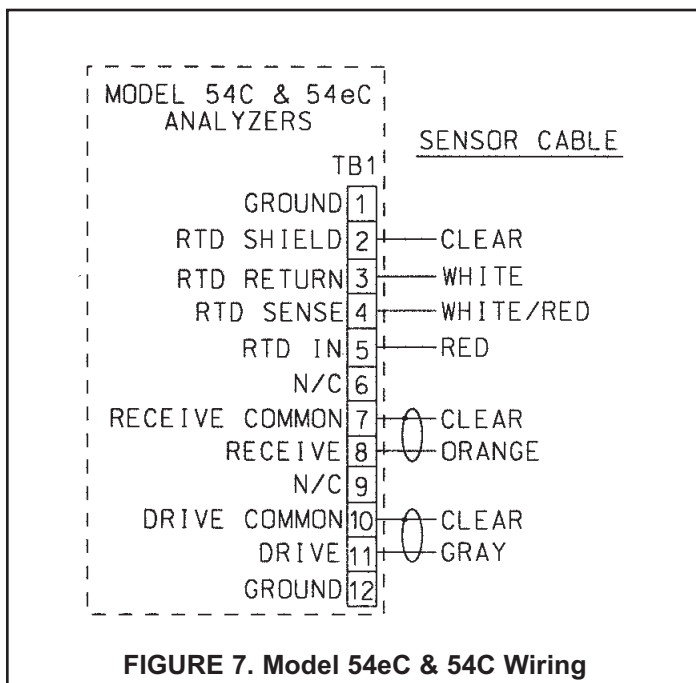

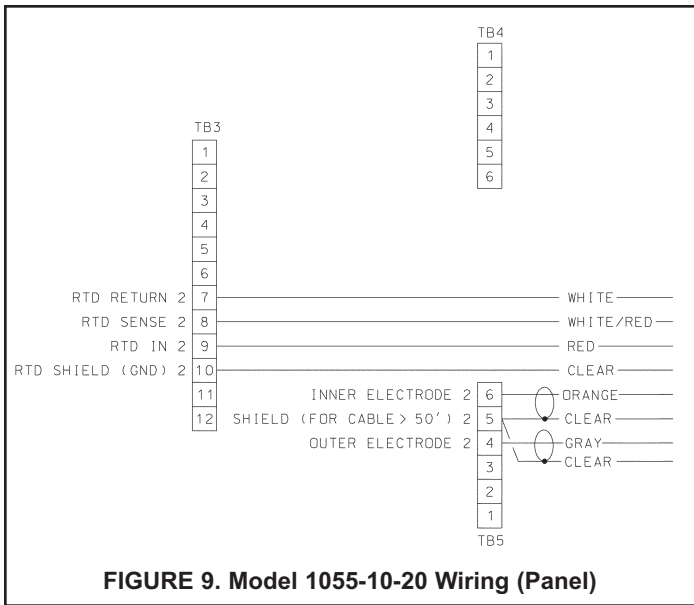

FIGURE 9. Model 1055-10-20 Wiring (Panel)

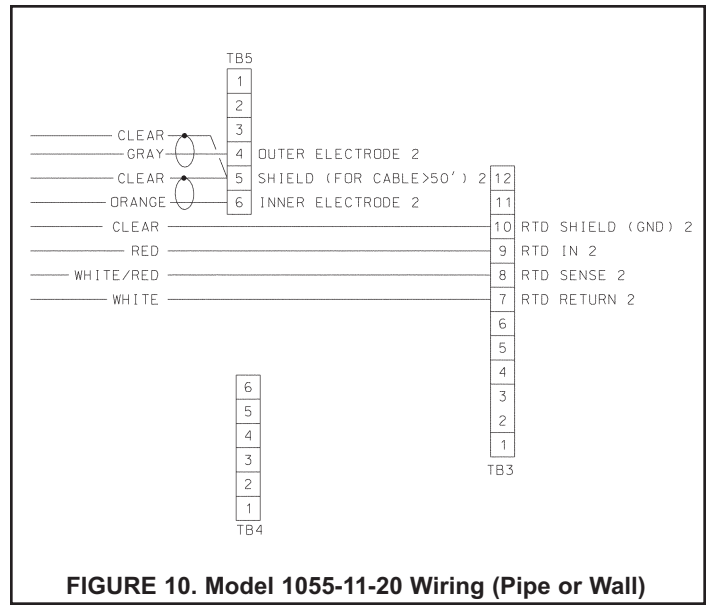

FIGURE 10. Model 1055-11-20 Wiring (Pipe or Wall)

NOTE: When using Model 400 or 400VP conductivity sensors with a pH sensor, refer to the pH sensor manual or to the Model 1055 wiring diagrams on our website (www.emersonprocess.com/raihome/liquid/library.asp) for more information.

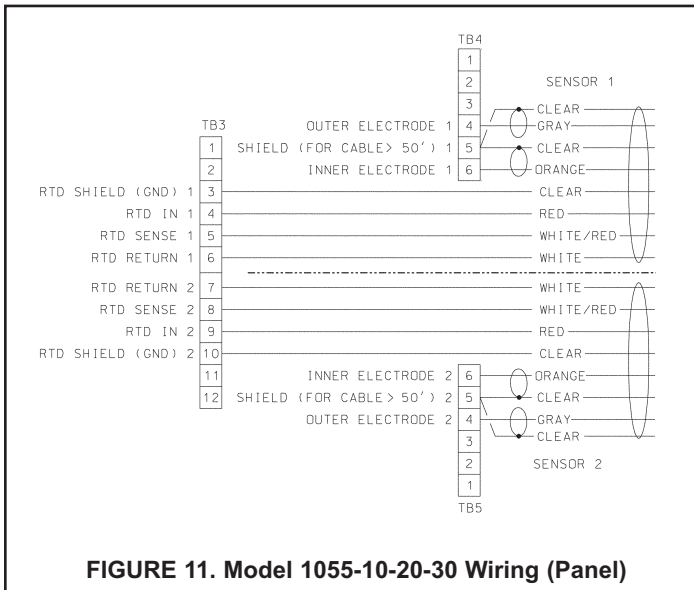

FIGURE 11. Model 1055-10-20-30 Wiring (Panel)

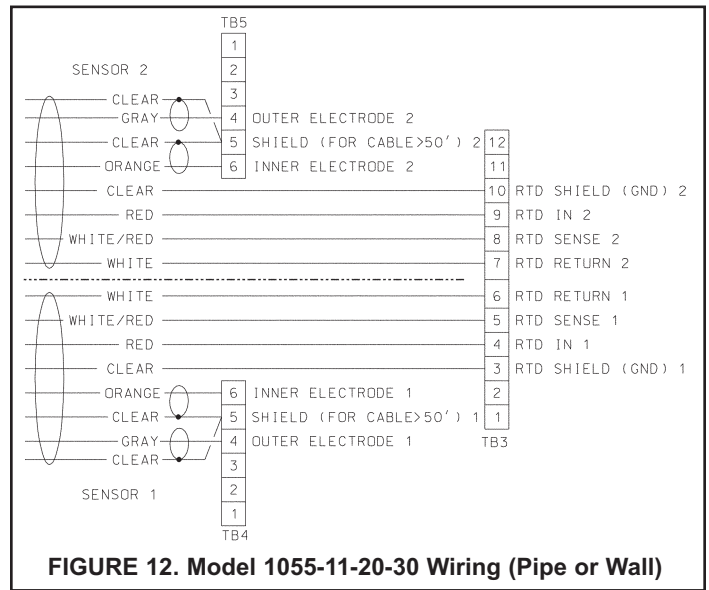

FIGURE 12. Model 1055-11-20-30 Wiring (Pipe or Wall)

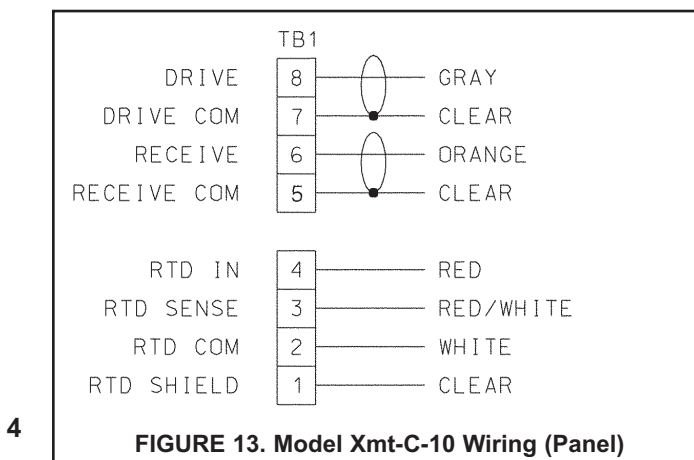

FIGURE 13. Model Xmt-C-10 Wiring (Panel)

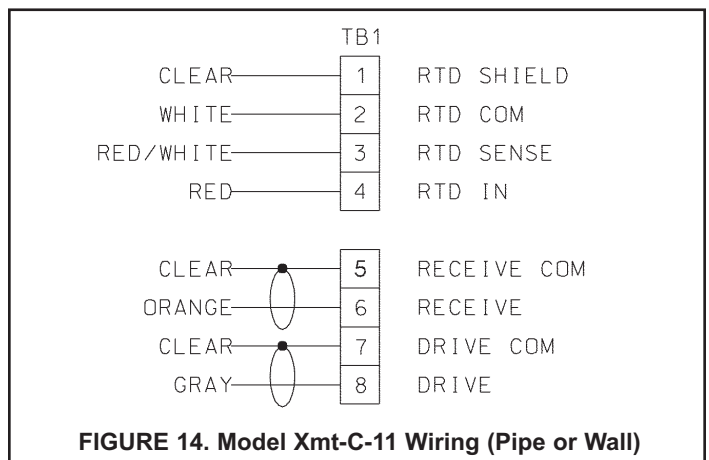

FIGURE 14. Model Xmt-C-11 Wiring (Pipe or Wall)

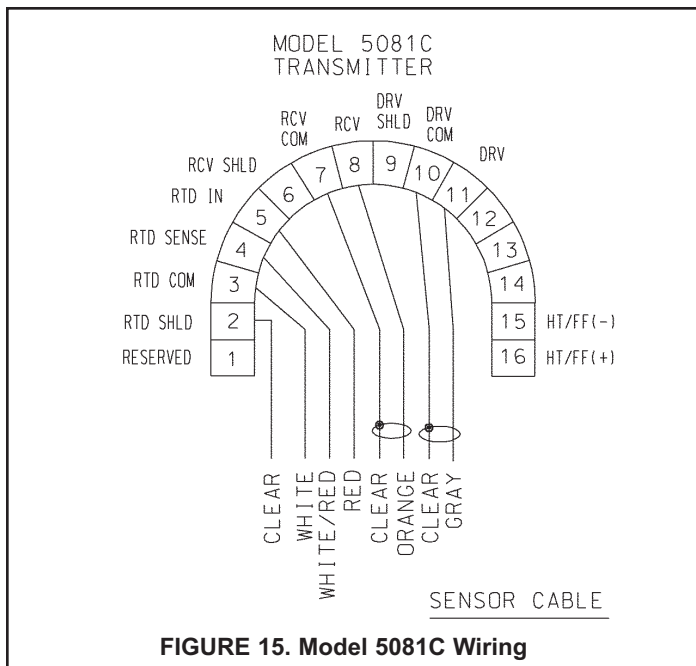

FIGURE 15. Model 5081C Wiring

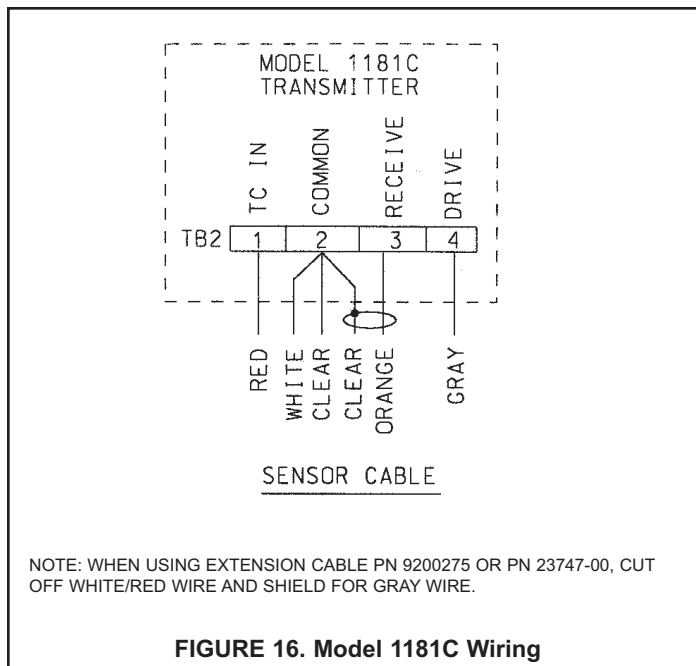

FIGURE 16. Model 1181C Wiring

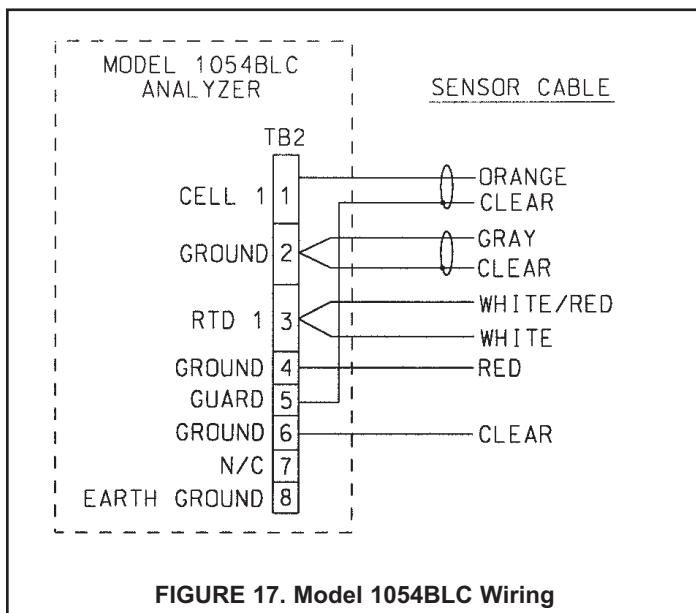

FIGURE 17. Model 1054BLC Wiring

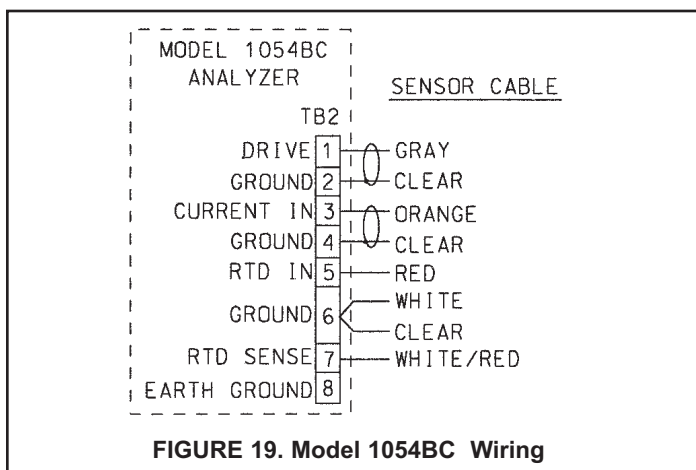

FIGURE 19. Model 1054BC Wiring

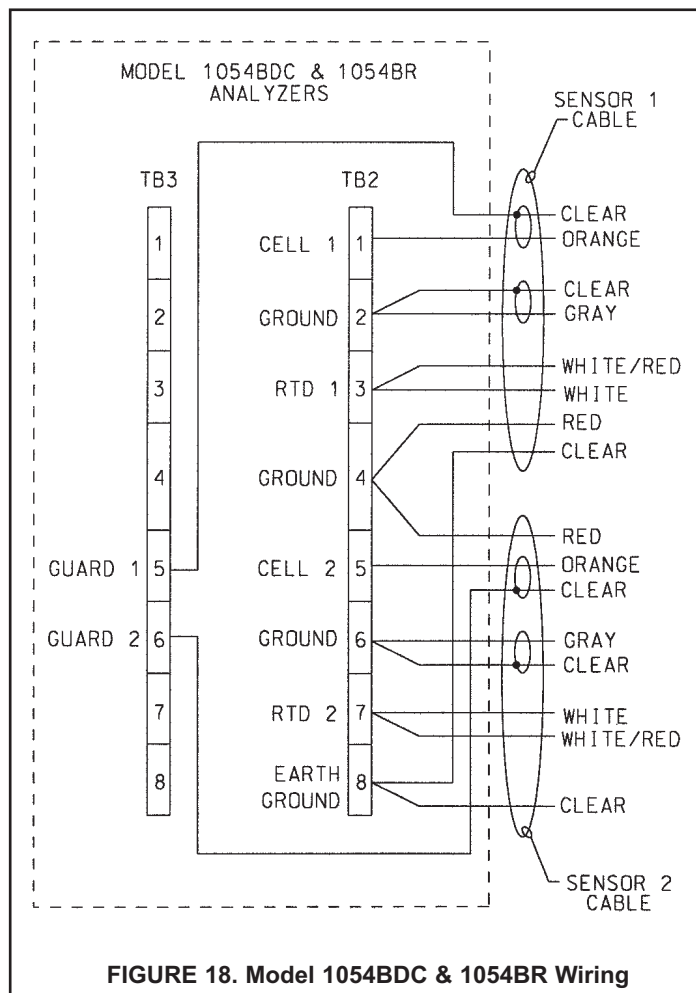
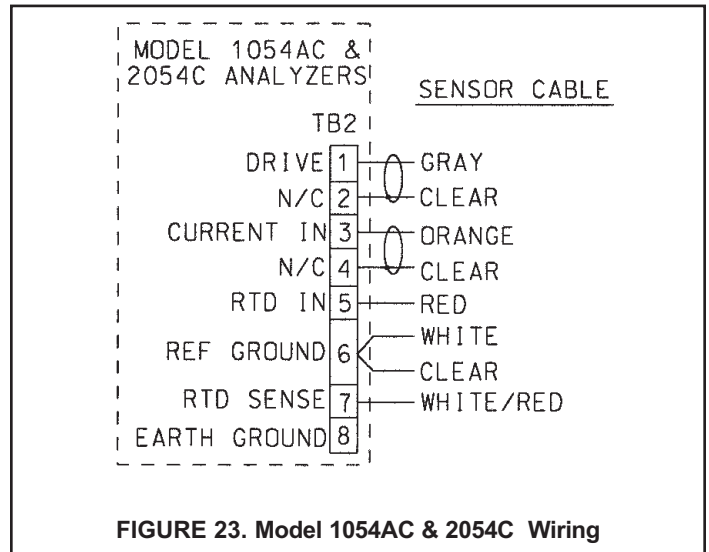
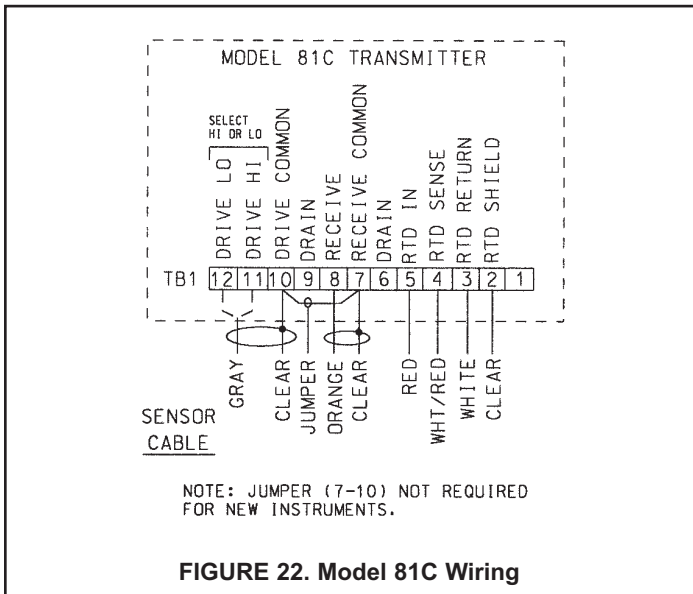
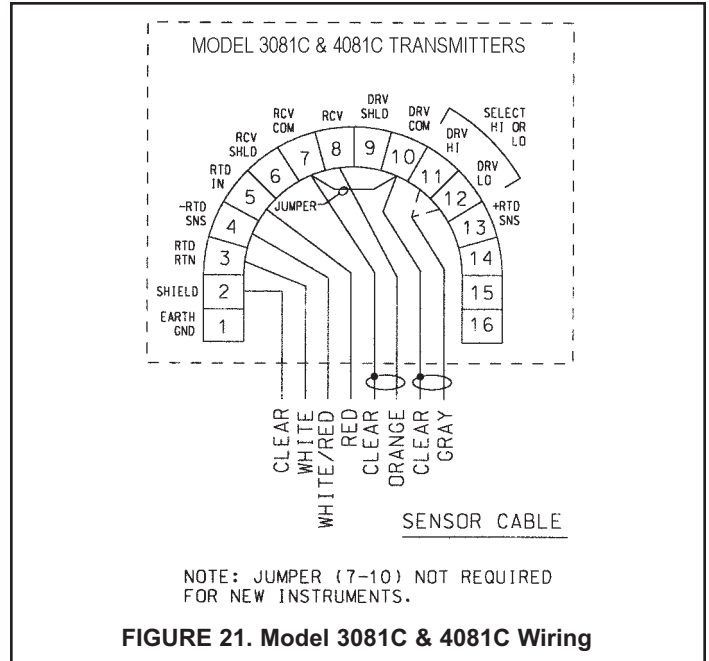
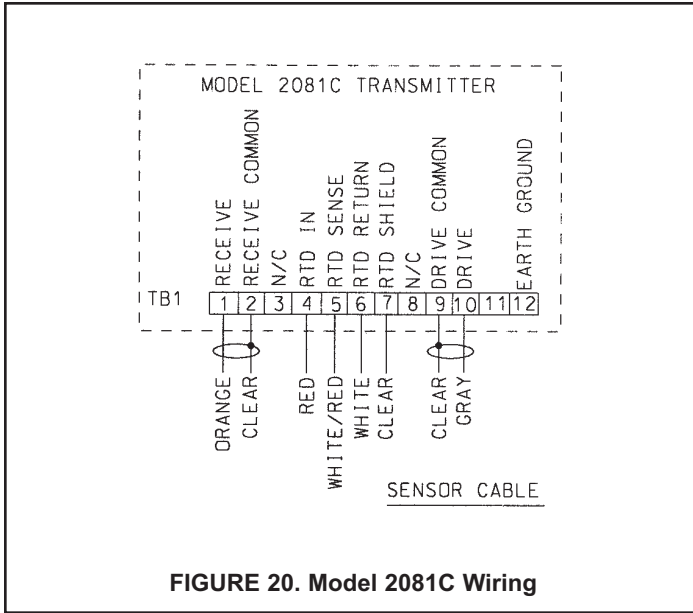

FIGURE 18. Model 1054BDC & 1054BR Wiring



WIRING THROUGH A JUNCTION BOX

Model 400-60 sensors have a junction box mounted on the end of the sensor. See Figure 24 for wiring instructions.

If wiring connections are made through a remote junction box (PN 23550-00), wire point-to-point. Use cable 23747-00 (factory-terminated) or 9200275 (no terminations).

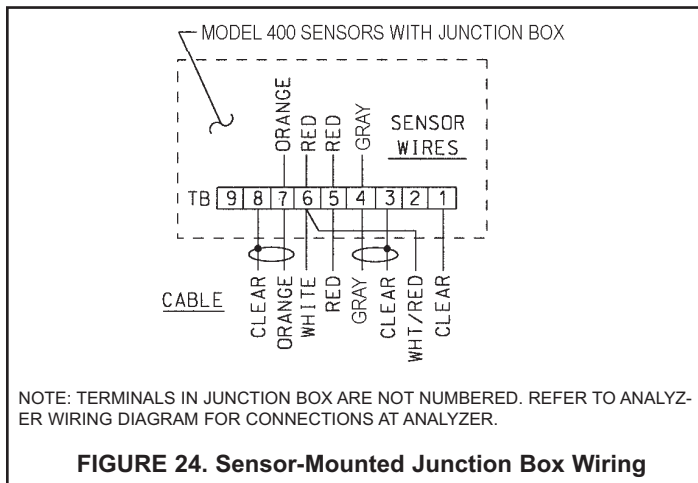

PIN OUT DIAGRAM FOR 400VP

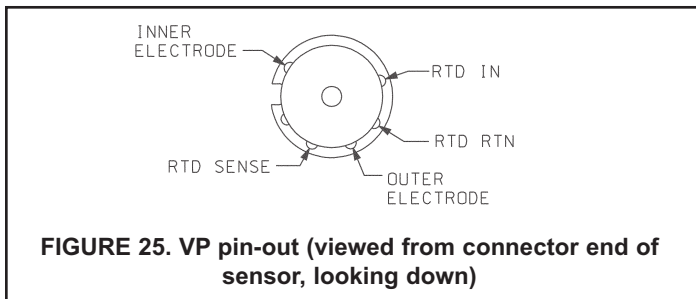

TROUBLESHOOTING

PROBLEM	PROBABLE CAUSE	SOLUTION
Off-scale reading	Wiring is wrong.	Verify wiring.
	Temperature element is open or shorted.	Check temperature element for open or shorts. See Figure 28.
	Sensor is not in process stream.	Be sure sensor is completely submerged in process stream.
	Sensor is defective.	Perform isolation checks. See Figure 29.
	Variopool cable is not properly seated.	Loosen connector and reseal.
Noisy reading	Sensor is improperly installed in process stream.	Be sure sensor is completely submerged in process stream.
	Variopool cable is not properly seated.	Loosen connector and reseal.
Reading seems wrong (lower or higher than expected)	Bubbles trapped in sensor.	Be sure sensor is properly oriented in pipe or flow cell. See Figure 1. Apply back pressure to flow cell.
	Wrong temperature correction algorithm.	Check that temperature correction is appropriate for the sample. See analyzer manual for more information.
	Wrong cell constant.	Verify that the correct cell constant has been entered in the analyzer and that the cell constant is appropriate for the conductivity of the sample. See analyzer manual.
Sluggish response	Electrodes are fouled.	Clean electrodes.
	Sensor is installed in dead area in piping.	Move sensor to a location more representative of the process liquid.

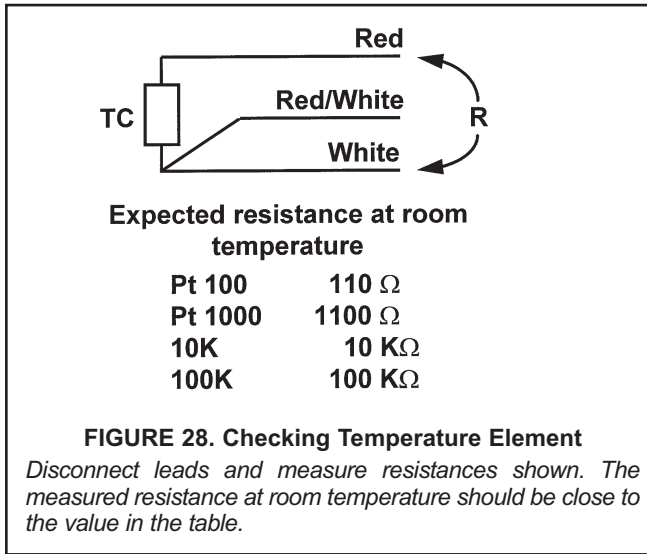

FIGURE 28. Checking Temperature Element

Disconnect leads and measure resistances shown. The measured resistance at room temperature should be close to the value in the table.

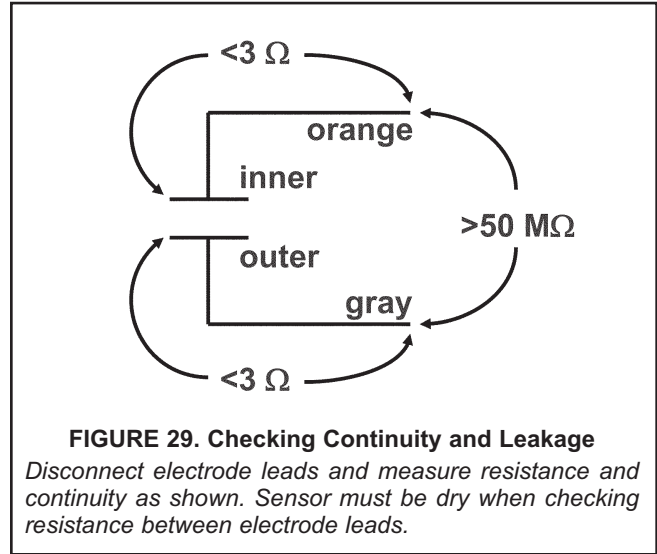

FIGURE 29. Checking Continuity and Leakage

Disconnect electrode leads and measure resistance and continuity as shown. Sensor must be dry when checking resistance between electrode leads.

CLEANING THE SENSOR

Use a warm detergent solution and a soft brush or pipe cleaner to remove oil and scale. Isopropyl alcohol (rubbing alcohol) can also be used to remove oily films. Avoid using acids to clean conductivity sensors.



*The right people,
the right answers,
right now.*

**ROSEMOUNT ANALYTICAL
CUSTOMER SUPPORT CENTER
1-800-854-8257**



ON-LINE ORDERING NOW AVAILABLE ON OUR WEB SITE
<http://www.raihome.com>

Specifications subject to change without notice.



Credit Cards for U.S. Purchases Only.



Emerson Process Management

Liquid Division

2400 Barranca Parkway
Irvine, CA 92606 USA
Tel: (949) 757-8500
Fax: (949) 474-7250

<http://www.raihome.com>

