

Instruction Manual

pH 1100/ pH 2100

Bench pH/Ion Meter



OAKION[®]

EUTECH
INSTRUMENTS

Technology Made Easy...

68X090818
Rev. 5 May 07

CE

ISO 9001
CERTIFIED

Part of ThermoFisher Scientific

PREFACE

Thank you for selecting the pH 1100/ 2100 benchtop meter. This meter measure pH, millivolts, relative millivolts and temperature. The pH 2100 meter also measures ion concentration.

The instruction manual serves to explain the use of the pH 1100/ 2100 bench meter as a step-by-step operational guide to help you familiarize with the meter's features and functions. It is structured sequentially with illustration of diagrams that explains the various functions and setup menus available.

This manual is written to cover as many anticipated applications and uses of the pH 1100/ 2100 Bench meter as possible. If there are doubts in the use of the meter, please do not hesitate to contact the nearest Authorized Distributor or Customer Service Dept. for assistance.

Eutech Instruments/ Oakton Instruments reserve the rights to change, make improvement and modify specifications without prior notice and cannot accept any responsibility for damage or malfunction to the instrument caused by improper use.

Copyright © 2002

Eutech Instruments Pte. Ltd.
Oakton Instruments

All rights reserved.
Rev. 4 Jan 07

TABLE OF CONTENTS

1	INTRODUCTION	6
1.1	Introducing the Bench Meter Series	6
1.2	Keypad	7
1.3	Rear Panel	8
1.4	Electrode Holder	9
2	STARTING UP	10
2.1	Back Panel Connections	10
2.2	Powering up and powering down	10
2.2.1	<i>Powering up</i>	10
2.2.2	<i>Powering down</i>	10
3	PH CALIBRATION & MEASUREMENT	11
3.1	pH calibration	11
3.1.1	<i>Automatic Temperature Compensation (ATC)</i>	11
3.1.2	<i>Starting pH calibration</i>	12
3.1.3	<i>Standard pH buffer calibration</i>	13
3.1.4	<i>Custom pH buffer calibration</i>	14
3.1.5	<i>Calibration error messages</i>	15
3.2	pH measurement	16
3.2.1	<i>Automatic temperature compensation</i>	16
3.2.2	<i>Adjusting manual temperature compensation</i>	16
3.2.3	<i>Taking pH Measurements</i>	17
4	mV CALIBRATION AND MEASUREMENT	18
4.1	mV Calibration	18
4.1.1	<i>mV Calibration error message</i>	18
4.2	mV Measurement	19
5	ION CALIBRATION AND MEASUREMENT (ONLY APPLICABLE FOR pH 2100)	20
5.1	Ion calibration	20
5.2	Ion calibration error messages	21
5.3	Ion measurement	22
6	MEMORY FUNCTIONS	23
6.1	Memory input	23
6.1.1	<i>Manually storing a reading into memory</i>	23
6.2	Memory recall	24
6.2.1	<i>Recalling readings in manual recall mode</i>	24
6.2.2	<i>Recalling readings in automatic recall mode</i>	24
7	STABILITY INDICATOR	25
8	ALARM FUNCTIONS	25
8.1	High and Low measurement alarm	25
8.2	Calibration due alarm	25
9	TEMPERATURE CALIBRATION	26
9.1	Temperature Calibration	26
9.2	Temperature Calibration Error Messages	26
10	SETUP MODE	27
10.1	Setup mode overview	27
10.1.1	<i>pH/Temperature setup submenus</i>	27
10.1.2	<i>mV setup submenus</i>	28
10.1.3	<i>Ion setup submenus (pH 2100 only)</i>	28
10.1.4	<i>Meter general configuration setup submenus</i>	29
10.2	pH/ temperature setup mode	30
10.2.1	<i>Entering pH/temperature setup mode</i>	30
10.2.2	<i>pH buffer setup program P1.0</i>	30
10.2.3	<i>pH resolution setup program P1.1</i>	31
10.2.4	<i>Temperature unit setup program P1.2</i>	31
10.2.5	<i>pH Measurement Alarm Setup Program P1.3</i>	32
10.2.6	<i>pH Calibration Due Alarm Setup program P1.4</i>	33
10.2.7	<i>Stability Setup Program P1.5</i>	34
10.2.8	<i>View pH calibration data setup program P1.6</i>	35

10.2.9	<i>pH calibration data reset setup program P1.7</i>	36
10.3	mV setup mode	37
10.3.1	<i>Entering mV setup mode</i>	37
10.3.2	<i>mV measurement alarm setup program P2.0</i>	38
10.3.3	<i>mV calibration due alarm setup program P2.1</i>	39
10.3.4	<i>Stability setup program P2.2</i>	40
10.3.5	<i>View mV calibration data setup program P2.3</i>	41
10.3.6	<i>mV calibration data reset setup program P2.4</i>	42
10.4	Ion setup mode (pH 2100 meter only)	43
10.4.1	<i>Entering ion setup mode</i>	43
10.4.2	<i>Ion unit setup mode P3.0</i>	43
10.4.3	<i>Ion measurement alarm setup program P3.1</i>	44
10.4.4	<i>Ion calibration due alarm setup program P3.2</i>	45
10.4.5	<i>Stability setup program P3.3</i>	46
10.4.6	<i>Ion mode setup program P3.4</i>	47
10.4.7	<i>View ion calibration data setup program P3.5</i>	48
10.4.8	<i>Ion calibration data reset setup program P3.6</i>	49
10.5	Meter general configuration setup mode	50
10.5.1	<i>Entering meter general setup mode</i>	50
10.5.2	<i>Date/time setup mode P4.0</i>	50
10.5.3	<i>Backlight setup mode P4.1</i>	51
10.5.4	<i>Data log setup mode P4.2</i>	52
10.5.5	<i>Memory recall setup mode P4.3</i>	52
10.5.6	<i>Communication setup mode P4.4</i>	53
10.5.7	<i>Data transfer setup mode P4.5</i>	53
10.5.8	<i>Memory clear setup mode P4.6</i>	54
10.5.9	<i>Meter reset setup mode P4.7</i>	54
11	ELECTRODE CARE	55
11.1	Electrode Activation	55
11.2	Electrode Maintenance	55
11.3	Storing pH/ORP electrodes	55
12	RS 232 COMMUNICATION	56
12.1	Using with printer	56
12.1.1	<i>Sending data to printer</i>	56
12.2	Using with computer	56
13	ADDITIONAL INFORMATION	57
13.1	pH and Temperature	57
13.2	pH Buffer Calibration Solution	57
13.3	Standard pH Buffers	57
14	SUMMARY OF DEFAULT SETTINGS / OPTIONS	58
15	TROUBLESHOOTING & ERROR MESSAGES	59
16	SPECIFICATIONS	60
17	ACCESSORIES	61
18	WARRANTY	62

1 INTRODUCTION

1.1 Introducing the Bench Meter Series

The pH 1100/ 2100 bench meter is microprocessor-based which incorporates new ASIC (Application Specific Integrated Circuit). It is designed with convenience in mind and offers many advanced, user-friendly features. The meters are capable of storing and recalling up to 100 data sets in its non-volatile memory. In addition, as a space saver, an optional swivel electrode holder can be attached at the either side of bench meter for resting the electrodes and probes during operation.

The pH 1100/ 2100-- bench meter measures pH, millivolts, relative millivolts and temperature. The pH 2100 meter also measures ion concentration. These meters are equipped with a large customized LCD (Liquid Crystal Display) with simultaneous display of the measured values for easy reading. It is most ideal for routine pH/Ion Concentration measurement in indoor applications.

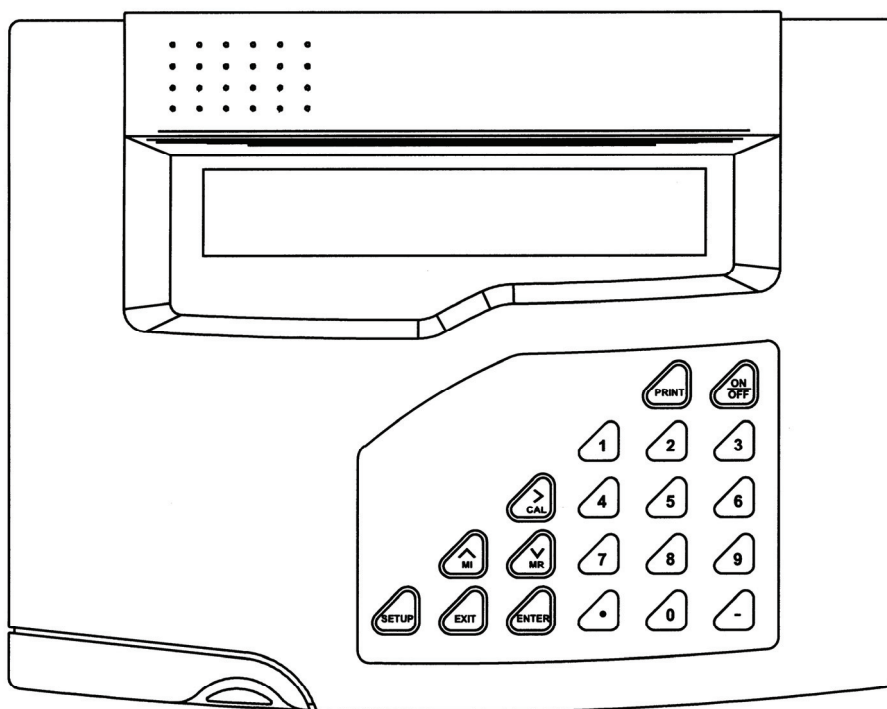

1.2 Keypad

See Figure 1.

A large membrane keypad with touch feedback makes the meter easy to use. Names and symbols describe the function button controls.

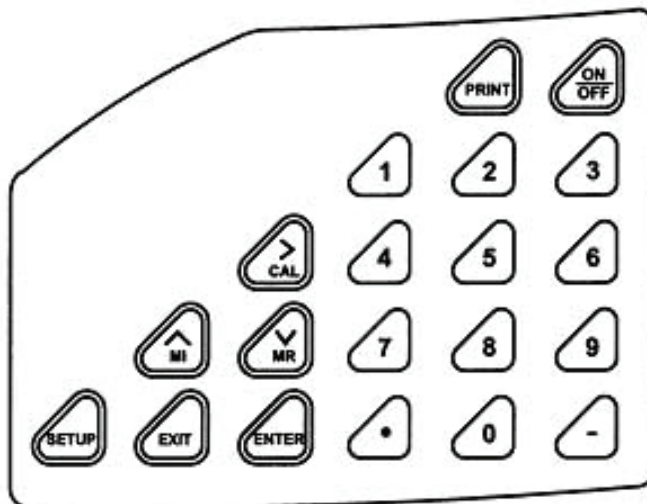

Figure 1: Membrane Keypad

ON/OFF	Power meter On or Off
ENTER	Confirm selection in all modes of operations; Scroll through the sub-menus program in the SETUP modes
EXIT	Exit from current modes of operations; Exit from calibration mode after 3 rd point calibration (for pH/Ion)
CAL / >	Enter into calibration modes of the meter; Select or scroll to the next options available
MODE	Select the measurement modes:- pH, Ion Concentration, mV, Relative mV
HOLD	Freeze the displayed value; allow you to print the held reading or store it into memory
SETUP	Enter SETUP mode of the meter for customization of meter functions as well as view some diagnostic functions (refer to the table for details of SETUP menus)
▲/ MI	Store the displayed value into memory; Increment values or scroll through the next options available
▼/ MR	Recall stored values from the memory in the Last-In-First-Out (LIFO) sequence; Decrement values or scroll through the next options available
PRINT	Send measured data being measured or data stored in the memory to a peripheral device via the RS232C port of meter
Numeric Keys (0-9 & .)	Enter numeric values and decimal point at appropriate places
- (Minus)	Enter negative sign at appropriate places

1.3 Rear Panel

See **Figure 2**.

The pH 1100/ 2100 meters provide a complete set of input connections for the various accessories commonly used.

Listed in the table below are details of the connections that you can make.

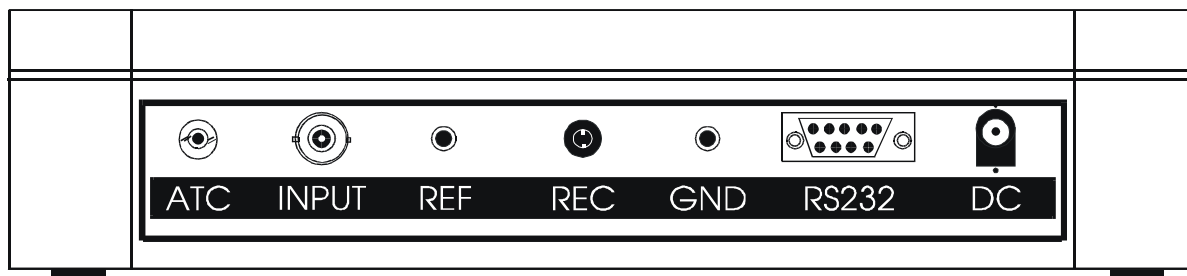

Figure 2: Rear View of Meter

Connector	Function
ATC	For phono jack connection from the temperature probe for Automatic Temperature Compensation. The probe should be a 30K Ω thermistor probe.
INPUT	For connecting sensors with a BNC connector to the meter. The meter accepts any pH, ORP or ISE electrode with a BNC connector. Always make sure that the connector is clean and dry.
REF	For connection to the pin tip type reference electrode normally used with half cell (mono) type pH or ISE electrodes.
REC	For connection to the strip chart recorder.
GND	For connection to the ground earth jack (standard pin tip connectors).
RS232	For connection to the RS232C serial port.
DC	For connection of the AC adapter power supply (included).

1.4 Electrode Holder

The electrode holder is included in the same box as the meter.

To attach the electrode holder to the meter:

1. The electrode holder base attached to the bottom of the meter comes in the shipping position. See **Figure 3**.
2. Use a Phillips screwdriver to remove the screw holding the electrode holder in shipping position. See **Figure 3**.
3. Slide the electrode base away from the meter until the second screw slot lines up with the original screw hole. Use the screw removed earlier to secure electrode holder base into position. See **Figure 3**.
4. The electrode holder arm is reversible. If desired, remove screw holding electrode holder base and slide base out of brackets. Slide base into brackets on opposite side and replace screw.
5. To install the electrode arm, turn meter back to the upright position. See **Figure 4**.
6. Line up the hole on the base of the electrode holder arm with the peg on the electrode holder base. Slide the hole securely onto the electrode holder base. See **Figure 4**.
7. The electrode arm is now ready to swing into desired position.

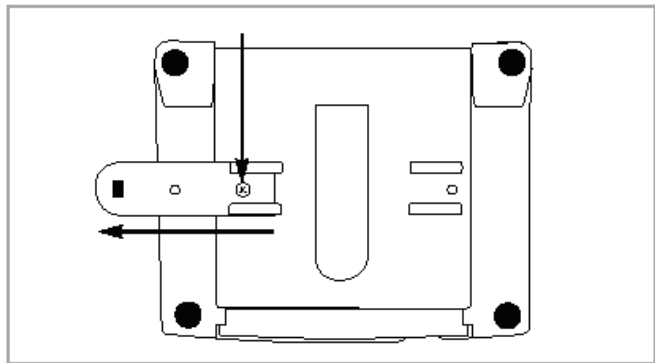
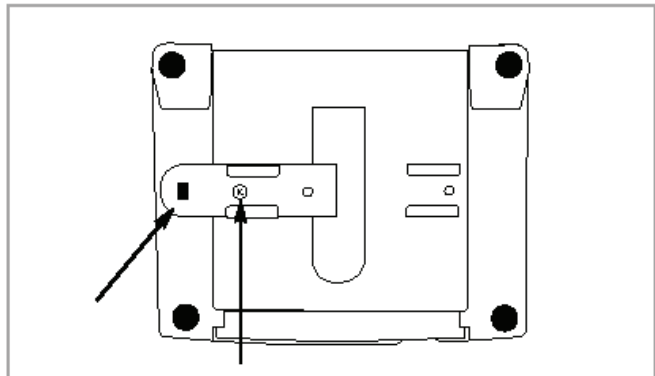

Figure 3: Bottom of Meter

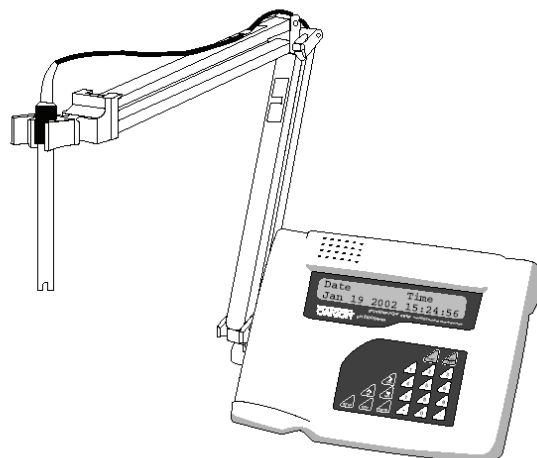
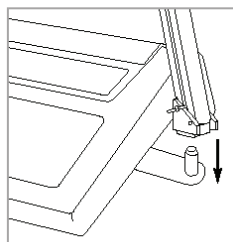
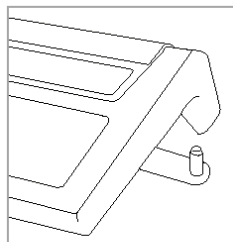

Figure 4: Fix electrode holder arm to holder base

2 STARTING UP

Attention: Do not get water on the BNC connector during operation. Avoid touching the connector with soiled or wet hands.

2.1 Back Panel Connections

Refer back to **Figure 2**. Make the necessary connections as mentioned in *Section 1.3 Rear Panel, pg 8*.

2.2 Powering up and powering down

2.2.1 Powering up

1. When first connected to the power supply, the meter runs a self test, the display flashes *Hardware Testing...* Status: Pass. See **Figure 5**.
2. It then displays current date and time. See **Figure 6**. This display will also appear when the meter is turned off while still connected to the power supply. See **Figure 6**.
3. See **Figure 7**. To turn the meter on press ON/OFF. The upper display flashes *Bench pH/Ion 2100* for the pH 2100, (Display flashes *Bench pH 1100* for the pH 1100 meter.) and then the lower display flashes *SW Rev 1.20*. See **Figure 7**.
4. The display flashes *System Initializing, Please wait...* See **Figure 8**.
5. If this is the first power up since the power was connected, you must indicate desired measurement mode. Use **>/CAL** to select. The mode selected will flash. See **Figure 9**. Press **ENTER** to confirm. The meter then enters measurement mode.
6. After initial startup, the meter will automatically return to the measurement mode previously selected as long as power connection is maintained.



Hardware Testing...
Status: Pass

Figure 5



Date Time
Jan 25 2002 09:09:30

Figure 6



Bench pH/Ion 2100
SW Rev 1.20

Figure 7



System Initializing
Please wait...

Figure 8

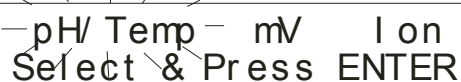

pH/Temp mV Ion
Select & Press ENTER

Figure 9



System Shutting Down
Please wait...

Figure 10

2.2.2 Powering down

1. **To turn the meter off** press **ON/OFF**. The display flashes *System Shutting Down, Please wait...* See **Figure 10**. Then, the date and time display will appear. See **Figure 6**. The date and time will continue to display until the power supply is disconnected.

3 PH CALIBRATION & MEASUREMENT

3.1 pH calibration

This meter is capable of up to 5 point calibration with selectable buffer sets (USA, NIST, Bf1, Bf2 or any 5 custom buffers of your choice). The meter retains stored pH calibrations even when turned off. For best accuracy, we recommend that you perform at least a 2-point calibration using buffers that bracket (one above and one below) the expected sample range. A single point cal is possible only at the offset points namely 7.00 or 6.86. For custom buffer sets, you must perform at least a 2 point calibration.

Selectable buffer sets:

USA: 1.68, 4.01, 7.00, 10.01, 12.45

NIST: 1.68, 4.01, 6.86, 9.18, 12.45

Bf1: 1.68, 4.01, 7.00, 9.18, 12.45

Bf2: 1.68, 4.01, 6.86, 10.01, 12.45

Any 5 user selected custom buffers

To select which buffer sets you wish to use see *Section 10.2.2: Program pH Buffer Setup: P1.0* in the *pH/Temp setup* mode (page 30).

When you recalibrate your meter, old pH calibration points are replaced on a point by point basis. For example, if you previously calibrated your meter at pH 4.01, 7.00, and 10.01, and you recalibrate at pH 7.00, the meter retains the old calibration data at pH 4.01 and pH 10.01. To view current calibration points, see *Section 10.2.8: Program pH Cal Data P1.6* in the *pH/Temp setup* mode (page 35).

If you choose to recalibrate to only 1 or 2 pH values, the older calibration values you do not calibrate to will remain stored. These old stored calibration values may cause accuracy loss when your readings are close to the old values. To clear old calibration data, reset the meter as shown in *Section 10.2.9 Program pH Cal Reset: P1.7* in the *pH/Temp setup* mode (page 36).

3.1.1 Automatic Temperature Compensation (ATC)

If you will be taking pH measurement using Automatic Temperature Compensation (ATC), you must perform your pH calibration with ATC temperature probe attached. Attach the temperature probe to the rear of the meter. The **ATC** mode annunciator shows on the display. See **Figure 11**. Insert the probe into the pH buffer solution along with your pH electrode.

If manual temperature compensation is preferred, do not plug a temperature probe into the meter. The **MTC** mode annunciator shows on the display. See **Figure 12**. The default manual temperature compensation is 25.0°C. To change the manual temperature compensation default, see *Section 9 Temperature Calibration* for instructions (page 26).

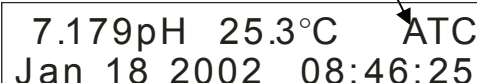

7.179pH 25.3°C ATC
Jan 18 2002 08:46:25

Figure 11

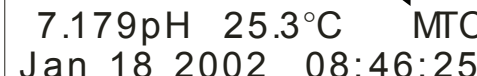

7.179pH 25.3°C MTC
Jan 18 2002 08:46:25

Figure 12

3.1.2 Starting pH calibration

1. Turn the meter **ON**. If the meter is not in the pH measurement mode, press **EXIT** and press **>/CAL** to select pH/Temp. The mode selected will flash. See **Figure 13**. Press **ENTER** to confirm selection. The meter is now in pH measurement mode. See **Figure 14**.
2. Rinse the electrode in deionized water or rinse solution. If using the ATC function with a separate temperature probe, rinse the temperature probe as well. **Do not wipe the pH electrode or temperature probe dry.** Wiping the probes causes static, and will create calibration and measurement instability.
3. Select pH buffer and pour into a clean container.
4. Dip the electrode and ATC probe into the calibration buffer. The end of the probes must be completely immersed into the sample. Stir probes gently to create a homogeneous sample.
5. Press **>/CAL** to enter the pH calibration mode. The display flashes *Cal Mode Activated, Please wait...*. See **Figure 15**. The meter is now in pH calibration mode.

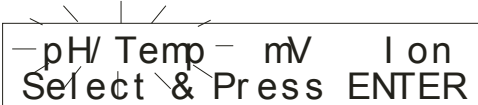

pH/Temp mV I on
Select & Press ENTER

Figure 13

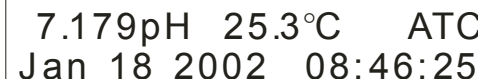

7.179pH 25.3°C ATC
Jan 18 2002 08:46:25

Figure 14



Cal Mbde Activated
Please wait...

Figure 15

The meter automatically recognizes the buffers in the set you have selected in the **SETUP** mode. If you wish to change the buffer set selected, see *Section 10.2.2, Program pH Buffer Setup: P1.0* in the *pH/Temp* setup mode (page 30). If your meter is set up for standard buffers (USA, NIST, Bf1, Bf2), proceed to *Section 3.1.3: Standard pH buffer calibration* (page 13). If your meter is set up for custom buffers, proceed to *Section 3.1.4: Custom pH buffer calibration* (page 14).

3.1.3 Standard pH buffer calibration

1. When entering the standard calibration mode, the first buffer calibration point for standard pH buffers is 7.000 or 6.860 (depending upon which pH buffer set is selected). The upper display shows the current reading, the lower display will show *Auto Buf Scan: 7.000* (or 6.860). The upper display will flash pH until the reading has stabilized. See **Figure 16**. If the selected buffer value is not within ± 1.0 of the measured pH value, the Auto pH Scan will continue to change until the pH buffer is within ± 1.0 .
2. When pH reading has stabilized, press **ENTER**. The lower display flashes **pH Offset Cal Done*. See **Figure 17**. This calibration point is now stored in the meter.
 - If you are performing a one-point calibration, press **EXIT**. The screen flashes *Sys Updating...Please wait....* The meter then returns to the pH measurement mode. You may now start taking pH readings.
 - If you are performing a multi-point calibration, go to step 3.
3. Rinse the probe with deionized water or a rinse solution, and place it in the next pH buffer. The lower display automatically scans to the next pH buffer solution.
4. Wait for the measured pH value to stabilize. The upper display will flash pH until the reading has stabilized.
5. When pH reading has stabilized, press **ENTER**. The lower display flashes *2 Point Cal Done ** (3 if you have calibrated 3 points, 4 if 4 points, etc.). See **Figure 18**. This calibration point is now stored in the meter. Repeat steps 3-5 for each point you wish to calibrate. When you are finished calibrating, press **EXIT**. The screen flashes *Sys. Updating... Please wait....* The meter then returns to the pH measurement mode. You may now start taking pH readings.
6. If you perform a complete 5-point pH calibration, when you calibrate the fifth point and press **ENTER**, the meter automatically returns to measurement mode. You may now start taking pH readings.

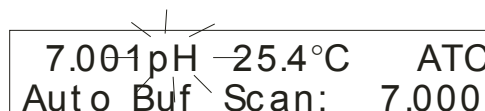

Figure 16

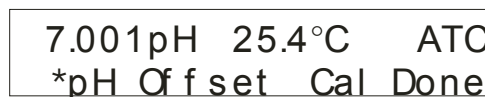

Figure 17

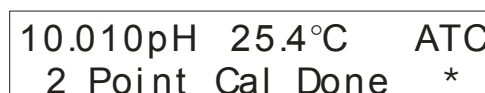

Figure 18

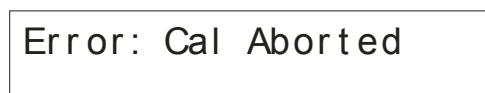

Figure 19

NOTE:

To exit from pH calibration mode at any point without confirming calibration, **DO NOT** press **ENTER** in steps 2, 5 or 6. Press **EXIT** instead. If **EXIT** is pressed before a 1-point calibration is performed the upper display flashes *Error: Cal Aborted*. See **Figure 19**.

DO NOT REUSE SOLUTIONS AFTER CALIBRATION.

Contaminants in the solution can affect the calibration, and eventually the accuracy of the measurements.

3.1.4 Custom pH buffer calibration

1. When entering the custom calibration mode, the lower display will show *Key In Std:*. The upper display shows the pH buffer the electrode is dipped into. The lower display will show the same value as the upper display only if the meter has not been calibrated or if the meter has been reset. See **Figure 20**. If the meter has previously been calibrated, the lower display will toggle to the stored calibration point that is closest to current buffer value.

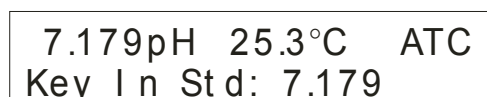

Figure 20

2. Using the numeric keypad (See **Figure 21**), enter the value of the first custom pH buffer. If you make a mistake, use the Δ /MI or ∇ /MR to highlight mistake, then retype.

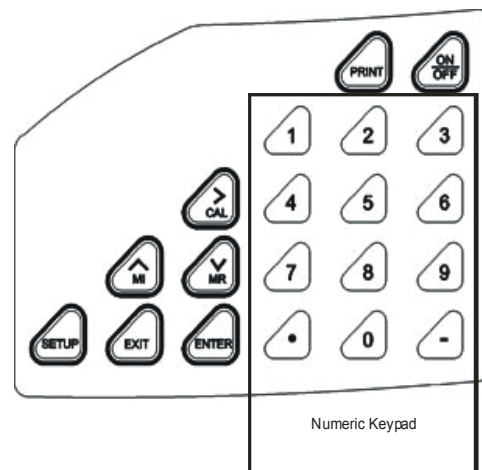

Figure 21

3. Press **ENTER** when first custom pH buffer is keyed in. The display will read *1 Point Cal Done **. See **Figure 22**.

NOTE: In the custom pH buffer calibration mode you must perform at least a 2-point calibration, if you press **EXIT** before you calibrate at 2 points the screen will flash *Error: Cal Aborted* (See Figure 23) and will return to the pH measurement mode without confirming any calibration points.

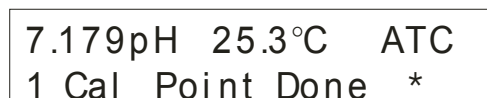

Figure 22

4. Rinse the probe with deionized water or a rinse solution, and place it in the next custom pH buffer. The lower display will show *Key In Std:*. The upper and lower displays show the pH buffer value.

5. Enter the value of the next custom pH buffer. Press **ENTER** when done. The display will read *2 Point Cal Done **. If you are performing a 2-point calibration, press **EXIT**. The screen flashes *Sys Updating...Please wait...*. The meter then returns to the pH measurement mode. You may now start taking pH readings.

- If you are performing a 3, 4 or 5-point calibration go to step 6.

6. Repeat steps 4 and 5 for each additional custom buffer. Upon confirmation of pH buffer, the display will read *3 Point Cal Done ** (4 if you have calibrated points, etc). When you have finished calibrating desired number of points, press **EXIT**. The screen flashes *Sys. Updating... Please wait...*. The meter then returns to the pH measurement mode. If you have entered 5 calibration points, the meter will automatically return to pH measurement mode. You may start taking pH readings.

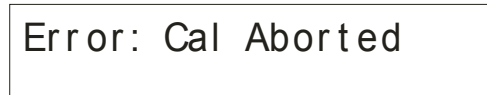

Figure 23

NOTE:

To exit from pH calibration mode at any point without confirming calibration, DO NOT press **ENTER** in steps 3 or 5. Press **EXIT**. If **EXIT** is pressed before a 2-point calibration is performed the upper display flashes *Error: Cal Aborted*. See **Figure 23**.

DO NOT REUSE SOLUTIONS AFTER CALIBRATION.

Contaminants in the solution can affect the calibration, and eventually the accuracy of the measurements.

3.1.5 Calibration error messages

Standard pH Buffer Calibration:

If the first buffer value of 7.000 or 6.860 is off by more than ± 1.0 , the upper display will flash *Error:* and the lower display will read *pH Offset Error*. See **Figure 24**. Press **EXIT** to clear error message and return to pH measurement mode.

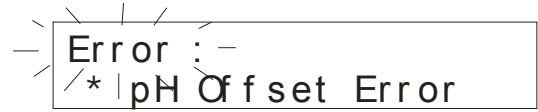

Figure 24

If any other pH buffer point is off by more than ± 1.0 , the upper display will flash *Error:* and the lower display will read *pH Slope Error*. See **Figure 25**. Press **EXIT**, to clear error message and return to pH measurement mode.

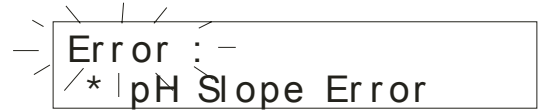

Figure 25

Custom pH Buffer Calibration:

If the each custom pH buffer value is not within ± 1.0 pH of the keyed in value, the upper display will flash *Error:* and the lower display will read *Too much offset @7pH*. See **Figure 26**. Press **EXIT** to clear error message and return to pH measurement mode.



Figure 26

If the slope is not within 75% to 105%, the upper display will flash *Error:* and the lower display will read *Slope out: 75% - 105%*.

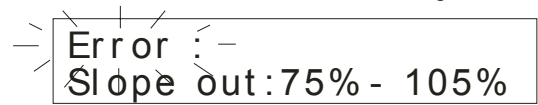

Figure 27

See **Figure 27**. Press **EXIT** to clear error message and return to pH measurement mode.

If adjacent calibration points are less than ± 1.0 pH apart, the upper display will read *Error: Pts too close*, and the lower display will read *OR slope diff. sign*. See **Figure 28**. Press **EXIT** to clear error message and return to pH measurement mode.

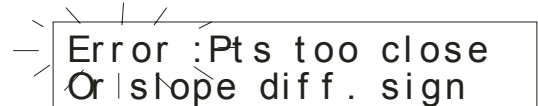

Figure 28

3.2 pH measurement

This meter is capable of taking measurements with automatic or manual temperature compensation. Automatic Temperature Compensation (ATC) occurs when a temperature sensor is plugged into the meter. If there is no temperature sensor plugged into the meter, the default setting is automatically 25°C (if the meter has never been manually set for temperature) or the last manually set value. You can manually set the temperature to match your working conditions using a separate thermometer.

3.2.1 Automatic temperature compensation

For automatic temperature compensation, simply plug the temperature probe into the meter (see page 8). The **ATC** indicator will light on the LCD. See **Figure 29**.

NOTE: If you are using a temperature probe, the probe must be submersed in the liquid you are measuring.

3.2.2 Adjusting manual temperature compensation

IMPORTANT: For manual compensation, you must disconnect the temperature probe.

1. Turn the meter **ON**. If the meter is NOT in the pH measurement mode, press **EXIT** and use **>/CAL** to select pH/Temp. The mode selected will flash. See **Figure 30**. Press **ENTER** to confirm selection. The meter is now in pH measurement mode. If the temperature probe is disconnected, the upper display will indicate **MTC**. See **Figure 31**.
2. Press **>/CAL** to enter pH/Temp calibration mode. The display will flash *Cal Mode Activated, Please wait...* Press **>/CAL** key again to enter the temperature calibration mode. The display will flash *Temperature Cal Mode*. See **figure 32**. The upper display then reads *MTC Temp: 25.0°C* and the lower display reads *Key In Std: 25.0°C*. See **Figure 33**.
3. Check the temperature of your sample using an accurate thermometer.
4. Key in the temperature value using the numeric keypad. If you make a mistake, use the **Δ/MI** or **∇/MR** key to highlight mistake, then re-enter.
5. Press **ENTER** to confirm temperature and to return to the pH measurement mode. Display will flash *Temp Cal Complete* in the upper display and *MTC Set Temp:* (temperature that was keyed in). See **Figure 34**. The display will flash *Sys. Updating...Please wait...* The meter then returns to pH measurement mode and will now compensate pH reading with the manually set temperature.

NOTE: To exit this program without confirming the manual temperature compensation value, do not press **ENTER** in step 5. Press **EXIT** instead. The display will flash *Error: Cal Aborted* and meter will return to pH measurement mode.



Figure 29

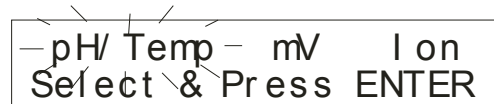

Figure 30

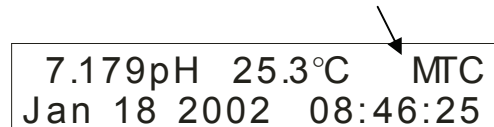

Figure 31



Figure 32

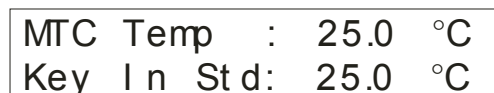

Figure 33

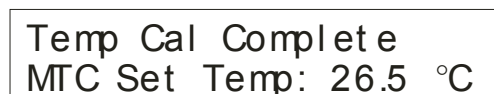
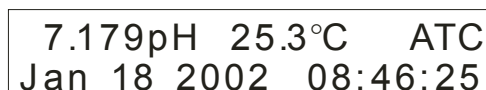

Figure 34

3.2.3 Taking pH Measurements

NOTE: Be sure to remove the electrode soaker bottle or protective rubber cap on the electrode before measurement.

1. Rinse the probe with deionized or distilled water before use to remove any impurities adhering to the probe body. If the pH electrode dehydrated, soak it for 30 minutes in electrode storage solution or a 2M to 4M KCl solution.
2. Press **ON**. The upper display shows current pH reading and temperature, and indicates automatic or manual temperature compensation. The lower display shows month, date, year and time. See **Figure 35**.
3. Dip the probe into the sample. Make sure the sensor or the glass bulb of the electrode is completely immersed into the sample. Stir the probe gently to create a homogenous sample.
4. Allow time for the reading to stabilize. The pH indicator blinks when reading is not stable. See **Figure 36**. When the readings stabilizes, the pH indicator freezes and no longer blinks.



7.179pH 25.3°C ATC
Jan 18 2002 08:46:25

Figure 35

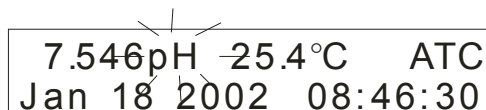

7.546pH 25.4°C ATC
Jan 18 2002 08:46:30

Figure 36

4 mV CALIBRATION AND MEASUREMENT

4.1 mV Calibration

1. Turn the meter **ON**. If the meter is not in the mV measurement mode, press **EXIT** and use **>/CAL** to select mV. The mode selected will flash. See **Figure 37**. Press **ENTER** to confirm selection. The meter is now in absolute mV measurement mode. See **Figure 38**.

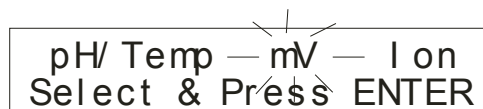

pH/Temp — mV — Ion
Select & Press ENTER

Figure 37

2. Rinse the electrode in deionized water or rinse solution. **Do not wipe the electrode dry.** Wiping the probes causes static, and will create calibration and measurement instability.



Abs. mV : 226.9mV
Jan 20 2002 20:30:05

Figure 38

3. Select your standard and pour into a clean container.
4. Dip the probe into the standard. The end of the probe must be completely immersed into the sample. Stir the probe gently to create a homogeneous sample.

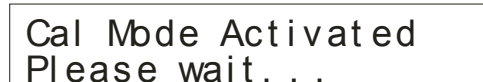

Cal Mode Activated
Please wait...

Figure 39

5. Press **>/CAL** key to enter the mV calibration mode. The display will read *Cal Mode Activated, Please wait...* See **Figure 39**. The meter is now in mV calibration mode. The upper display shows *Abs. mV*: and lower display shows *Key In Std*: See **Figure 40**.



Abs. mV : 226.9mV
Key In Std: 226.9 mV

Figure 40

NOTE: In mV calibration, the value shown in the upper display is the same as the lower display.



mV Cal Completed
mV Offset: -3.7 mV

Figure 41

6. Key in the mV value to match the standard value using the numeric keypad. If you make a mistake, use the **Δ/MI** or **∇/MR** to highlight mistake, then re-enter.

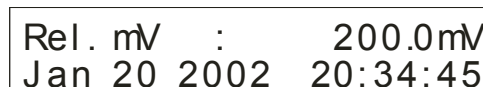

Rel. mV : 200.0mV
Jan 20 2002 20:34:45

Figure 42

7. Press **ENTER** key to confirm the reading. The display flashes *mV Cal Completed, mV Offset*: (shows the mV offset value). See **Figure 41**. It then flashes *Sys Updating... Please wait...* The meter returns to mV measurement mode. The upper display now reads *Rel. mV*. See **Figure 42**.



Error: Cal Aborted

Figure 43

NOTE: New mV calibrations will override existing the stored mV calibration data. The meter retains stored mV calibrations even when the meter is turned off.

To exit from mV calibration mode at any point without confirming calibration, DO NOT press **ENTER** in step 7. Press **EXIT**.

The upper display then flashes *Error: Cal Aborted*. See **Figure 43**.



Error : -
mV Offset too large

Figure 44

4.1.1 mV Calibration error message

If the offset adjustment of your mV calibration is not within ± 150.0 mV; the upper display will flash *Error*: and the lower display will read *mV Offset too large*. See **Figure 44**. Press **EXIT** to clear error message and return to mV measurement mode.

4.2 mV Measurement

1. Turn the meter **ON**. If the meter is NOT in the mV measurement mode, press **EXIT** and use **>/CAL** to select mV. The mode selected will flash. See **Figure 45**. Press **ENTER** to confirm selection.

Figure 45

The meter is now in Rel mV measurement mode. See **Figure 46**. If you have not performed a mV calibration or have reset the meter, the display will read Abs. mV. See **Figure 47**.

2. Dip the electrode into the sample. The sensor or glass bulb of the electrode must be completely immersed into the sample. Stir the electrode gently to create a homogeneous sample.
3. Allow time for the reading to stabilize. The upper display will show the mV reading, and the lower display will show the current month, day and time. See **Figure 46**.

Figure 46

Figure 47

5 ION CALIBRATION AND MEASUREMENT (ONLY APPLICABLE FOR pH 2100)

The pH 2100 meter reads ion concentration in ppm, ppt, mg/l, g/l, mmol/l and mol/l units. See *Ion setup Program P3.0* (page 43) to select ion concentration units.

5.1 Ion calibration

This instrument is capable of up to 5-point custom ion calibration with a minimum of 2-point calibration. Custom calibration values can be any value between 0.001 and 19998. Once the first calibration value is keyed in, all other calibration will automatically be at least one decade apart.

For example if your first calibration point is at 0.001, all other calibration points will be at least one decade apart from 0.001 (0.001, 0.01, 0.1, 1.0, 10.0, 100, 1000, 10000).

For best accuracy calibrate your meter to points with similar concentrations to the solutions you want to test.

1. Connect an Ion Selective Electrode (ISE) to the BNC input connector on the back of the meter.
2. Turn the meter **ON**. If the meter is not in the Ion measurement mode, press **EXIT** and use **>/CAL** to select Ion. The mode selected will flash. See **Figure 48**. Press **ENTER** to confirm selection. The meter is now in Ion measurement mode.
3. If the meter has not been calibrated or has been reset, the display will flash *Ion Meas* and current mV value. See **Figure 49**. If the meter has been calibrated previously, the display will show the current concentration value plus the absolute mV produced by the electrode.
4. Dip the electrode into the first calibration standard. Start with the calibration standard that has the lowest concentration and move up to higher concentration standards.
5. Press **>/CAL** to enter the ion calibration mode. The display will flash *Cal Mode Activated, Please wait...* See **Figure 50**. The display then shows *Ion Conc: ppm* (or unit selected in ion setup mode) in the upper display and *Abs. mV:* in the lower display. See **Figure 51**.
6. The first calibration point must be keyed in by the user. Key in the concentration value of the standard using the numeric keypad. If you make a mistake, use the **Δ/MI** or **∇/MR** keys to highlight mistake, then re-enter.
7. Press **ENTER** to confirm the first calibration point. The display will flash *1 Cal Point Done **, then the meter proceeds to the next calibration point at least 1 decade apart from the first calibration point. See **Figure 52**.
8. Use **Δ/MI** or **∇/MR** keys to move the cursor to next calibration point. All points will be a decade apart from the first calibration point.
9. Rinse off the electrode with deionized water before placing it in the next calibration standard.
10. Allow probe to stabilize in calibration standard. Press **ENTER** to confirm. The display flashes *2 Point Cal Done **. See **Figure 53**.
The meter proceeds to the next calibration point.



Figure 48

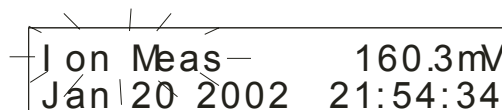

Figure 49

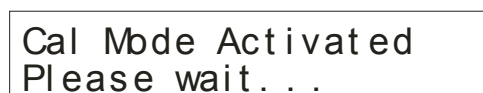

Figure 50

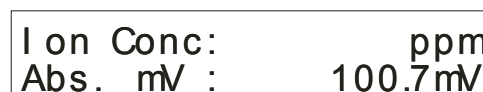

Figure 51

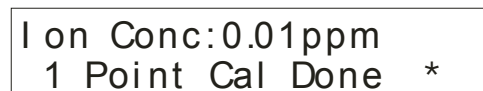

Figure 52

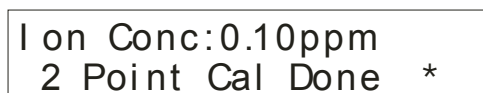

Figure 53

If you are performing a 2-point calibration, press **EXIT**.

The screen flashes *Aver. Slope =* (the average slope of the electrode) in the upper display and *Sys Updating...* in the lower display. See **Figure 54**. The meter returns to the Ion measurement mode. You may now start taking readings.

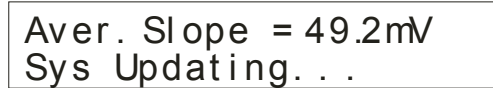

Figure 54

If you are performing a 3, 4 or 5-point calibration go to step 11.

11. Use **Δ/MI** or **∇/MR** keys to move the cursor to next calibration point.
12. Rinse off the electrode with deionized water before placing it in the next calibration standard.
13. Allow probe to stabilize in calibration standard. Press **ENTER** to confirm. The display flashes *3 Point Cal Done * (4 for 4 point, etc.)*. See **Figure 55**. The meter proceeds to the next calibration point.
14. Repeat steps 11-13 until you finish calibrating at desired number of points (up to 5 points). Press **EXIT**. The screen flashes *Aver.Slope =* (the average slope of the electrode) in the upper display and *Sys Updating...* in the lower display. See **Figure 54**. The meter returns to the Ion measurement mode. At the end of a 5-point calibration, the meter automatically flashes *Aver. Slope =* and *Sys Updating*, and returns to measurement mode.

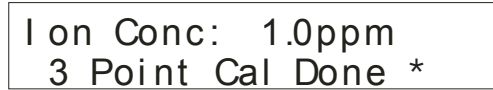

Figure 55

NOTES: You may compare the average electrode slope value with the expected slope value for your electrode from your electrode manual to verify electrode operation. If you want to leave the calibration mode prior to confirming two calibration points, press **EXIT** key to exit calibration mode. The meter will revert to back to the earlier calibration curve. If you have calibrated to two points, pressing **EXIT** will confirm the new calibration. New ion calibrations will over-ride the existing stored ion calibration data. The meter retains stored ion calibrations even when the meter is turned off or if the power cord is unplugged or power is cut off to the AC adapter.

5.2 Ion calibration error messages

If you leave the ion calibration mode prior to confirming two calibration points by pressing the **EXIT** key, the screen will flash *Error: Cal Aborted*. See **Figure 56**. The meter will revert to back to the earlier calibration curve and return to the ion measurement mode.

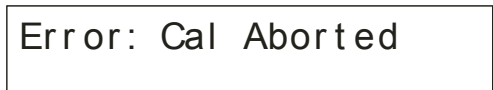

Figure 56

If the average ion slope is not within 10 to 75 mV per decade, the upper display will flash *Error:* and the lower display will read *Ion Slope Error*. See **Figure 57**.



Figure 57

5.3 Ion measurement

The pH 2100 meter features two different modes of ion measurement: high resolution mode and low resolution mode. These modes are user selectable in the *Ion setup program P3.4* (page 47). The default is high resolution mode. Low resolution mode should only be used if your ion solution concentration will produce an absolute mV value of ± 500 mV.

1. Turn the meter **ON**. If the meter is NOT in the Ion measurement mode, press **EXIT** and use **>/CAL** to select Ion. The mode selected will flash. See **Figure 58**. Press **ENTER** to confirm selection. The meter is now in Ion measurement mode. If the meter has not been calibrated, or has been reset, the display will flash *Ion Meas* and current mV value. See **Figure 59**. If the meter has been calibrated, the display will show the current concentration value plus the absolute mV produced by the electrode. See **Figure 60**.

2. Prepare samples as necessary. Sample preparations varies depending on ion type—see your electrode manual for details on the specific electrode that you are using.
3. Dip electrode into the sample. The sensor or glass bulb of the electrode must be completely immersed into the sample.
4. Allow time for the reading to stabilize, then record your measurement.

NOTE: The display in the ion measurement mode shows mV that correlates to the electrode output. Charge in mV will typically be 59.7 mV for monovalent ions (1+ or 1- charge) and 29.8 mV for divalent ions (2+ or 2- charge).



pH/ Temp mV Ion
Select & Press ENTER

Figure 58

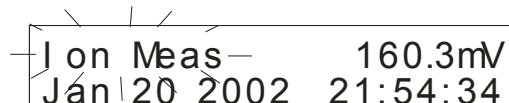

Ion Meas 160.3mV
Jan 20 2002 21:54:34

Figure 59



0.013ppm 160.3mV
Jan 21 2002 21:35:34

Figure 60

6 MEMORY FUNCTIONS

6.1 Memory input

This meter can store up to 100 sets of data in several combinations:

pH 1100 meter:

- pH, temperature, date and time
- mV, temperature, date and time

pH 2100 meter:

- pH, temperature, date and time
- mV, temperature, date and time
- ion, mV, date and time

For example, you can store 32 pH and 68 mV values for the pH 1100 or 50 ion, 25 mV and 25 pH values for the pH 2100. This meter can be setup to log readings automatically or manually. To set the meter to log automatically, see *Meter Setup Program P4.2, Data Log Setup* (page 52). The meter can log readings at intervals from 10 seconds to 23 hours 59 minutes and 59 seconds.

6.1.1 Manually storing a reading into memory

1. During any measurement mode function, press Δ /MI key to input data into memory.
2. The upper display will read current measurement function and the lower display will flash *Data Log.... Loc:* (the memory storage location). See **Figure 61**. The meter then returns to measurement mode.

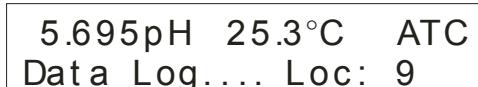

5.695pH 25.3°C ATC
Data Log.... Loc: 9

Figure 61

NOTE: If the memory is full, the first value stored will be erased to create space for the new value.

6.2 Memory recall

This function recalls the previous readings stored in the memory. You can only access memory recall from the measurement mode. Memory recall is in “Last In First Out” (LIFO) order.

There are two methods of viewing stored data in the memory recall function: manual and automatic. In manual memory recall, the user must manually scroll through the memory points using the Δ /MI and ∇ /MR keys. In automatic memory recall, the meter automatically scrolls through the memory points. To choose the method of viewing stored data you wish to use, see *Meter Setup mode Program P4.3 MemRecall Setup* (page 52).

6.2.1 Recalling readings in manual recall mode

1. Press the ∇ /MR key once to retrieve the last reading stored. The display flashes *Mem Recall Activated, Please wait...* See **Figure 62**.

The display then flashes the memory location last stored in the lower display. See **Figure 63**. Then the display shows the recorded value (pH/temp, mV or Ion/mV) in the upper display and toggles between memory location and date in the lower display. See **Figures 64-65**.

2. Use the ∇ /MR key to select the next memory location or the Δ /MI key to select the previous memory location.
3. Repeat step 2 to review additional stored data sets.
4. To exit Memory Recall, press **EXIT** and return to the measurement mode.

6.2.2 Recalling readings in automatic recall mode

1. Press the ∇ /MR key once to retrieve the last reading stored.

The display flashes *Mem Recall Activated, Please wait...* See **Figure 62**. The display then flashes the memory location last stored in the lower display. See **Figure 63**. Then the display shows the recorded value (pH/temp, mV or Ion/mV) in the upper display and date and time in the lower display. See **Figure 64**.

2. After 8 seconds, the meter automatically scrolls to the next memory location. The display flashes the next memory location stored. See **Figure 66**. The display then shows the recorded value (pH/temp, mV or Ion/mV) in the upper display and date and time in the lower display. See **Figure 67**.
3. The meter will continuously scroll through all the memory points stored indefinitely. To exit memory recall, press **EXIT** and return to the measurement mode.

NOTES: If no new readings are stored after memory recall function has been exited, the next time the memory recall function is activated, it will resume at the memory location point where it was last exited. If a new point is stored, the memory recall function will begin with that point. Readings stored in memory are retained even if the unit is turned off. To erase all readings stored in memory, see *Meter Setup Program P4.6, Mem Clear Setup* (page 54).



Mem Recall Activated
Please wait...

Figure 62



Mem Loc:9

Figure 63

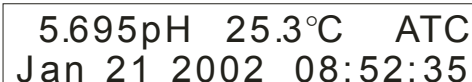

5.695pH 25.3°C ATC
Jan 21 2002 08:52:35

Figure 64

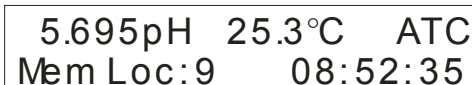

5.695pH 25.3°C ATC
Mem Loc:9 08:52:35

Figure 65



Mem Loc:8

Figure 66

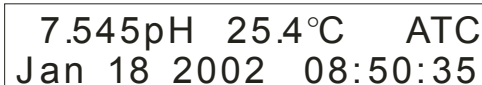

7.545pH 25.4°C ATC
Jan 18 2002 08:50:35

Figure 67

7 STABILITY INDICATOR

The stability indicator signals when pH, mV or Ion readings are stable. The pH, mV or Ion annunciator will blink when reading are not stable. See **Figure 68**. Once the reading becomes stable the annunciator becomes static and no longer blinks.

You can turn the stability indicator on and off and set the level of stability in *pH Setup Section P1.5* (page 34); *mV Setup P2.2* (page 40); and *Ion Setup P3.3* (page 46).

Figure 68

8 ALARM FUNCTIONS

8.1 High and Low measurement alarm

Your meter has high and low measurement alarms that can be individually set for pH, mV and Ion (pH 2100 only). To set high and low measurement alarms, please refer to the setup sections *pH Setup P1.3* (page 32); *mV Setup P2.0* (page 38); and *Ion Setup P3.1* (page 44).

If the measured value exceeds the alarm setting, the meter will “beep”; the upper display flashes measured parameter flashes; and the lower displays *Hi-Alarm* or *Lo-Alarm*. See **Figures 69** and **70**.

The following conditions are necessary to signal an alarm:

- **pH:** The high alarm must be at least 1.0 pH greater than the low alarm
- **mV:** The high alarm setting must be at least 100.0 greater than the low alarm
- **Ion:** The high alarm setting must be at least half of the next decade greater than the low alarm

Figure 69

Figure 70

Figure 71

8.2 Calibration due alarm

You can set this meter to signal an alarm when calibration is due. Individual calibration due alarms can be set for pH, mV and Ion (pH 2100 only) at a period of 1 to 365 days from the last calibration.

To set calibration due alarm, please refer to the setup sections *pH Setup P1.4* (page 33); *mV Setup P2.1* (page 39); and *Ion Setup P3.2* (page 45). The meter will “beep” during power up if calibration is due. The upper display will read *pH* (mV or Ion) *Calibration Due*, the lower display will flash *Calibration* and read *Abort*. See **Figure 71**.

Use **>ICAL** to select *Calibration* or *Abort*.

- Select **Calibration** to enter calibration mode and begin meter calibration.
- Select **Abort** to override alarm. Meter reverts to measurement mode.

Press **ENTER** to confirm selection.

9 TEMPERATURE CALIBRATION

9.1 Temperature Calibration

For this calibration procedure, the ATC probe should be attached to the meter. ATC will appear in the upper display. See **Figure 72**.

1. Dip the temperature probe into a solution of known temperature, such as a temperature bath, for a few minutes until the temperature probe stabilizes.
2. If you are not already in pH/temp measurement mode, press **EXIT** and use **>/CAL** to select pH/Temp. The mode selected will flash. See **Figure 73**. Press **ENTER** to confirm selection. The meter is now in pH measurement mode.
3. Press **>/CAL** to enter pH/Temp calibration mode. The display will flash *Cal Mode Activated, Please wait...* Press **>/CAL** again to enter the temperature calibration mode. The display will flash *Temperature Cal Mode*. See **Figure 74**. Then the upper display will read *ATC Temp: (current temperature)* and the lower display will read *Key In Std: (current temperature)*. See **Figure 75**.
4. Key in the known temperature value from step 1 using the numeric keypad. If you make a mistake, use the **Δ/MI** or **▽/MR** keys to highlight mistake, then re-enter.
5. Press **ENTER** to confirm. The display flashes *Temp Cal Complete, ATC Offset:* (shows offset value). See **Figure 76**. The display then flashes *Sys Updating, Please wait...*, and the meter returns to pH measurement mode.

NOTE: The meter will not allow input values that exceed the allowable limit of $\pm 5^{\circ}\text{C}$ ($\pm 9^{\circ}\text{F}$) of the original displayed reading.

9.2 Temperature Calibration Error Messages

If you press **EXIT** to leave the temperature calibration mode prior to confirming the calibration, the screen will flash *Error: Cal Aborted*. See **Figure 77**. The meter then returns to pH measurement mode. If the temperature value keyed in (temperature offset) is not within $\pm 5.0^{\circ}\text{C}$ ($\pm 9.0^{\circ}\text{F}$) of the current temperature value, the upper display will flash *Error:* and the lower display will read *ATC offset too large*. See **Figure 78**. The meter returns to temperature calibration mode and a new temperature offset value needs to be entered.

7.546pH 25.3°C ATC
Jan 18 2002 08:46:30

Figure 72

pH/Temp - mV Ion
Select & Press ENTER

Figure 73

Temperature Cal Mode

Figure 74

ATC Temp : 25.0 °C
Key In Std: 25.0 °C

Figure 75

Temp Cal Complete
ATC Offset: 2.0 °C

Figure 76

Error: Cal Aborted

Figure 77

Error :-
ATC Offset too large

Figure 78

10 SETUP MODE

The advanced setup mode lets you customize your meter's preferences and defaults. The pH 2100 benchtop meter features 4 different setup modes (the pH 1100 meter features 3 modes):

1. pH/Temperature
2. mV
3. Ion (pH 2100 only)
4. Meter general configuration

Each setup mode has submenus to configure specific meter parameters.

10.1 Setup mode overview

10.1.1 pH/Temperature setup submenus

Press **SETUP** to enter setup mode from the pH measurement mode. Use **>/CAL** to select pH/Temp, and then press **ENTER** to enter pH/Temp setup mode. Use the **Δ/MI** and **∇/MR** keys to scroll through sub menus. There are 8 sub menus (programs) in the pH/Temperature setup mode:

pH Buffer Setup:P1.0
-Selects calibration buffer sets (USA, NIST, Bf1, Bf2 or custom)

pH Buffer Setup: P1.0
Press ENT. to Select
see page 30

pH Resolution Setup:P1.1
-Selects pH resolution (0.01 or 0.001 pH)

pH Resol. Setup: P1.1
Press ENT. to Select
see page 31

Temperature Unit Setup:P1.2
-Selects temperature measurement unit (°C or °F)

Temp Unit Setup: P1.2
Press ENT. to Select
see page 31

pH Measurement Alarm Setup P1.3
-Sets low and high pH alarm

pH Meas. Alarm :P1.3
Press ENT. to Select
see page 32

pH Calibration Due Alarm Setup:P1.4
-Sets calibration reminder alarm, select 1-365 days from last calibration date

pH Cal Due Alarm: P1.4
Press ENT. to Select
see page 33

Stability Setup:P1.5
-Sets stability indicator criteria, off or on (high, medium or low)

Stability Setup: P1.5
Press ENT. to Select
see page 34

View Calibration Data:P1.6
-Last pH calibration date/time
-pH buffer set selected
-pH calibration temperature and temperature compensation mode
-pH offset value
-pH slopes (from acid to alkaline)

pH Cal Data :P1.6
Press ENT. to Select
see page 35

pH Calibration Reset:P1.7
-Clears all pH calibration data

pH Cal Reset :P1.7
Press ENT. to Select
see page 36

10.1.2 mV setup submenus

Press **SETUP** to enter setup mode. Use **>/CAL** to select mV, and then press **ENTER**. Use the **Δ/MI** and **∇/MR** keys to scroll through submenus. There are 5 submenus (programs) in the mV setup mode:

mV Measurement Alarm Setup :P2.0

-Sets low and high mV alarms

mV Meas. Alarm : P2.0
Press ENT. to Select

see page 38

mV Calibration Due Alarm Setup: P2.1

-Sets calibration reminder alarm, select 1-365 days from last calibration date

mV Cal Due Alarm : P2.1
Press ENT. to Select

see page 39

Stability Setup:P2.2

-Sets stability indicator criteria, off or on (high, medium or low)

Stability Setup: P2.2
Press ENT. to Select

see page 40

View mV Calibration Data:P2.3

-Last mV calibration date/time
mV offset value

mV Cal Data : P2.3
Press ENT. to Select

see page 41

mV Calibration Reset:P2.4

-Clears all mV calibration data

mV Cal Reset : P2.4
Press ENT. to Select

see page 42

10.1.3 Ion setup submenus (pH 2100 only)

Press **SETUP** to enter setup mode from the Ion measurement mode. Use **>/CAL** to select ion, and then press **ENTER**. Use the **Δ/MI** and **∇/MR** keys to scroll through submenus. There are 7 submenus (programs) in the ion setup mode:

Ion Unit Setup:P3.0

-Selects Ion measurement unit(ppm, ppt, mg/L, g/L, mmol/L, mol/L)

Ion Unit Setup : P3.0
Press ENT. to Select

see page 43

Ion Measurement Alarm Setup:P3.1

-Sets low and high Ion alarms

Ion Meas. Alarm : P3.1
Press ENT. to Select

see page 44

Ion Calibration Due Alarm Setup:P3.2

-Sets calibration reminder alarm, select 1-365 days from last calibration date

Ion Cal Due Alarm : P3.2
Press ENT. to Select

see page 45

Stability Setup:P3.3

-Sets stability indicator criteria, off or on (high, medium or low)

Stability Setup: P3.3
Press ENT. to Select

see page 46

Ion Mode Setup:P3.4

-Selects between high or low Ion resolution mode (high has ±500 mV value, low has ±1850 mV value)

Ion Mode Setup: P3.4
Press ENT. to Select

see page 47

View Calibration Data:P3.5

-Last Ion calibration date/time. Calibration points with absolute mV values
Ion slopes (from low to high concentration)

Ion Cal Data : P3.5
Press ENT. to Select

see page 48

Ion Calibration Reset:P3.6

-Clears all Ion calibration data

Ion Cal Reset : P3.6
Press ENT. to Select

see page 49

10.1.4 Meter general configuration setup submenus

Press **SETUP** to enter setup mode. Use **>/CAL** to select meter, and then press **ENTER**. Use the **Δ/MI** and **∇/MR** keys to scroll through submenus. There are 8 submenus (programs) in the meter setup mode:

Date/Time Setup:P4.0
Sets day, month, year, hour and minute

Date/ Time Set up:P4.0
Press ENT. to Select
see page 50

Backlight Setup:P4.1
-Turns backlight on or off and selects amount of time backlight stays on after button press

Backlight Set up:P4.1
Press ENT. to Select
see page 51

Data Log Setup:P4.2
-Sets automatic or manual memory recall and sets datalogging time interval (10 seconds to 23 hours, 59 minutes, 59 seconds).

Data Log Set up:P4.2
Press ENT. to Select
see page 52

Memory Recall Setup:P4.3
-Selects automatic or manual memory recall.

MemRecall Set up:P4.3
Press ENT. to Select
see page 52

Rs232 Communication Setup:P4.4
-Sets Baud Rate (4800, 9600 or 19200)
-Sets Stop Bit (One or Two)
-Sets Parity (None, Odd or Even)

Tx/ Rx Parameter: P4.4
Press ENT. to Select
see page 53

Data Transfer Setup:P4.5
-Selects what data gets sent to computer/printer when PRINT

Data Transfer :P4.5
Press ENT. to Select
see page 53

Memory Clear Setup:P4.6
Clears data from stored memory

Mem Clear Set up:P4.6
Press ENT. to Select
see page 54

Meter Reset:P4.7
-Resets meter to factory defaults
-Resets baud rate to 9600
-Resets stop bit to 2
-Resets parity to EVEN
-Clears all pH/mV/Ion calibration data
-Resets manual temperature compensation to 25.0°C
-Resets pH/mV/Ion measurement alarm to OFF
-Resets pH/mV/Ion calibration due alarm to OFF
-Resets stable indicator to ON with low stability setting
-Resets datalogging and memory recall to manual
-Resets backlight to ON with 2.0 minute duration
-Clears all data from stored memory

Meter Reset :P4.7
Press ENT. to Select
see page 54

10.2 pH/ temperature setup mode

10.2.1 Entering pH/temperature setup mode

1. Turn the meter **ON**. If the meter is not in the pH measurement mode, press **EXIT** and use **>/CAL** to select pH/Temp. The mode selected will flash. Press **ENTER** to confirm. The meter is now in pH measurement mode.
2. Press **SETUP** to enter the setup mode. The display will flash *Setup Mode Activated, Please wait...* See **Figure 79**.
3. The meter then enters the pH/Temp Meter Setup screen. Use **>/CAL** to select pH/Temp. The mode selected will flash. See **Figure 80**. Press **ENTER** to enter pH/Temp setup mode.
4. The first setup program in pH/Temp mode is *pH Buffer Setup: P1.0*. See **Figure 81**. If you want to skip to another program, use the **Δ/MI** and **∇/MR** keys to scroll to the desired program.
5. To exit the setup mode at anytime, press **EXIT**. The meter returns to the pH/Temp measurement mode.

NOTE: To exit the setup mode at anytime without confirming changes, press **EXIT**. If you have made any changes to any programs and press **EXIT**, these changes will be confirmed. To reset meter to default factory settings, see setup program *Meter Reset P4.7* (page 54).

Setup Mde Activated
Please wait...

Figure 79

Setup: pH/ Temp Meter
Select & Press ENTER

Figure 80

pH Buffer Setup: P1.0
Press ENT. to Select

Figure 81

10.2.2 pH buffer setup program P1.0

Use this program to select calibration buffer sets: USA, NIST, Bf1, Bf2 or custom.

Selectable buffer sets:

USA: 1.68, 4.01, 7.00, 10.01, 12.45

NIST: 1.68, 4.01, 6.86, 9.18, 12.45

Bf1: 1.68, 4.01, 7.00, 9.18, 12.45

Bf2: 1.68, 4.01, 6.86, 10.01, 12.45

Custom: any 5 user selected custom buffers

1. Enter the pH/Temperature setup mode as described above (10.2.1 Entering pH/temperature setup mode). The first setup mode is *pH Buffer Setup: P1.0*. See **Figure 81**.
2. Press **ENTER** to enter program *pH Buffer Setup: P1.0*.
3. Press **>/CAL** key to toggle between *USA NST Bf1 Bf2 Cust*. Buffer set selected will flash. See **Figure 82**.
4. Press **ENTER** to confirm selection and return to the setup mode. Press **Δ/MI** key to continue to the next setup program, or press **∇/MR** to go to the previous program (P1.7 pH Calibration Reset). Press **EXIT** to return to the pH measurement mode.

USA NST Bf 1 Bf 2 Cust
Select & Press ENTER

Figure 82

10.2.3 pH resolution setup program P1.1

Use this program to select pH resolution (0.01 or 0.001 pH).

1. Enter pH/Temperature setup mode as described in steps 1-4 in 10.2.1 *Entering pH/temperature setup mode* (page 30).
2. Use Δ/MI key to scroll to program *pH Resol. Setup: P1.1*. See **Figure 83**.
3. Press **ENTER** to enter program *pH Resol. Setup: P1.1*.
4. Press $>/CAL$ to toggle between *0.01* and *0.001*. The resolution selected will flash. See **Figure 84**.
5. Press **ENTER** to confirm selection and return to the setup mode. Press Δ/MI to continue to the next setup program, or press ∇/MR to go to the previous program. Press **EXIT** to return to the pH measurement mode.



Figure 83

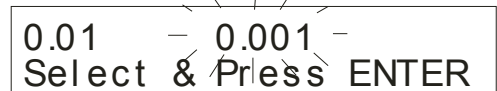

Figure 84



Figure 85

10.2.4 Temperature unit setup program P1.2

Use this program to select temperature measurement unit ($^{\circ}C$ or $^{\circ}F$).

1. Enter pH/Temperature setup mode as described in steps 1-4 in 10.2.1 *Entering pH/temperature setup mode* (page 30).
2. Use Δ/MI key to scroll to program *Temp Unit Setup: P1.2*. See **Figure 85**.
3. Press **ENTER** to enter program *Temp Unit Setup: P1.2*.
4. Press $>/CAL$ to toggle between *Degree C* and *Degree F*. The unit selected will flash. See **Figure 86**.
5. Press **ENTER** to confirm selection and return to the setup mode. Press Δ/MI to continue to the next setup program, or press ∇/MR to go to the previous program. Press **EXIT** to return to the pH measurement mode.



Figure 86

10.2.5 pH Measurement Alarm Setup Program P1.3

Use this program to select alarm for low and high pH measurements.

1. Enter pH/Temperature setup mode as described in steps 1-4 in 10.2.1 *Entering pH/temperature setup mode* (page 30).
2. Use Δ/MI to scroll to program *pH Meas. Alarm: P1.3*. See **Figure 87**.
3. Press **ENTER** to enter program *pH Meas. Alarm: P1.3*.
4. Press $>/CAL$ to toggle between pH Alarm *On* and *Off*. The selection will flash. See **Figure 88**.
5. Press **ENTER** to confirm selection.
 - If you selected **On** continue to step 6
 - If you select **Off**, pressing **ENTER** returns to the setup mode.

Press Δ/MI key to continue to the next setup program, or press ∇/MR to go to the previous program. Press **EXIT** to return to the pH measurement mode.

6. If you selected **On**, the display now reads *Key in Low Alarm pH Set Point*. Key in the low pH alarm set point using the numeric keypad. If you make a mistake, use the Δ/MI or ∇/MR keys to highlight mistake, then re-enter. See **Figure 89**. Press **ENTER** to confirm keyed in value.
7. The display now reads *Key in High Alarm pH Set Point*. Key in the high pH alarm set point using the numeric keypad. The high alarm must be set at least 1.0 pH greater than the low alarm. If you make a mistake, use the Δ/MI or ∇/MR keys to highlight mistake, then re-enter. See **Figure 90**.
8. Press **ENTER** to confirm high pH set point value and return to the setup mode.

Press Δ/MI key to continue to the next setup program, or press ∇/MR to go to the previous program. Press **EXIT** to return to the pH measurement mode.

pH Meas. Alarm :P1.3
Press ENT. to Select

Figure 87

pH Alarm— On — Of f
Select & Press ENTER

Figure 88

Key I n Low Alarm
pH Set Point:2 .000

Figure 89

Key I n High Alarm
pH Set Point:14 .000

Figure 90

10.2.6 pH Calibration Due Alarm Setup program P1.4

Use this program to set a reminder when the next calibration is due. Choose from 1 to 365 days from last calibration.

1. Enter pH/Temperature setup mode as described in steps 1-4 in *10.2.1 Entering pH/temperature setup mode* (page 30).
2. Use Δ/MI to scroll to program *pHCalDue Alarm: P1.4*. See **Figure 91**.
3. Press **ENTER** to enter program *pHCalDue Alarm: P1.4*.
4. Press $>/CAL$ to toggle between Cal Alarm Due: *On* and *Off*. The selection will flash. See **Figure 92**.
5. Press **ENTER** to confirm selection.
 - If you selected **On**, continue to step 6
 - If you select **Off**, pressing **ENTER** returns to the setup mode.

Press Δ/MI to continue to the next setup program, or press ∇/MR to go to the previous program. Press **EXIT** to return to the pH measurement mode.

6. If you selected **On** in step 5, the display reads *Key in Cal Due Period (1-365 days) =*. Key number of days using the numeric keypad. If you make a mistake, use the Δ/MI or ∇/MR keys to highlight mistake, then re-enter. See **Figure 93**.
7. Press **ENTER** to confirm number of days to next calibration, screen flashes *Sys Updating, Please wait...* and returns to the setup mode. Press Δ/MI key to continue to the next setup program, or press ∇/MR to go to the previous program. Press **EXIT** to return to the pH measurement mode.

pHCalDue Alarm : P1.4
Press ENT. to Select

Figure 91

Cal Alarm Due: On-Off
Select & Press ENTER

Figure 92

Keyin Cal Due Period
(1-365 days) = 1

Figure 93

10.2.7 Stability Setup Program P1.5

Use this program to turn on or off the pH stability indicator and to set level of stability (low, medium or high).

Stability definitions

High stability:

reading is stabilized quickly, but reading is less accurate.

Medium stability:

reading stability is averaged between high and low stability.

Low stability:

reading is stabilized slowly, but guarantees high accuracy

1. Enter pH/Temperature setup mode as described in steps 1-4 in *10.2.1 Entering pH/temperature setup mode* (page 30).
2. Use Δ/MI to scroll to program *Stability Setup: P1.5*. See **Figure 94**.
3. Press **ENTER** to enter program *Stability Setup: P1.5*.
4. Press **>ICAL** key to toggle between pH Stable Criteria: *On* and *Off*. The selection will flash. See **Figure 95**.
5. Press **ENTER** to confirm selection.
 - If you selected **On**, continue to step 6.
 - If you select **Off**, pressing **ENTER** returns to the setup mode.

Press Δ/MI to continue to the next setup program, or press ∇/MR to go to the previous program. Press **EXIT** to return to the pH measurement mode.

6. If you selected **On** in step 5, the display now reads *Degree of Stability: Low Medium High*. Press **>ICAL** to toggle between *Low*, *Medium* and *High*. The selection will flash. See **Figure 96**.
7. Press **ENTER** to confirm selection and return to the setup mode. Press Δ/MI to continue to the next setup program, or press ∇/MR to go to the previous program. Press **EXIT** to return to the pH measurement mode.

Stability Setup : P1.5
Press ENT. to Select

Figure 94

pH Stable Criteria
— On — Off

Figure 95

Degree of Stability
Low — Medium High

Figure 96

10.2.8 View pH calibration data setup program P1.6

Use this program to view the following:

- Last pH calibration date/time
- pH buffer set selected
- pH calibration temperature and temperature compensation
- pH offset value
- pH slopes (from acid to alkaline)

1. Enter pH/Temperature setup mode as described in steps 1-4 in 10.2.1 *Entering pH/temperature setup mode* (page 30).
2. Use Δ /MI to scroll to program *pH Cal Data: P1.6*. See **Figure 97**.
3. Press **ENTER** to enter program *pH Cal Data: P1.6*. The first screen in *pH Cal Data: P1.6* is the pH Cal Date/Time. See **Figure 98**.
4. Press **ENTER** to proceed to the second screen. This screen shows current buffer set and calibration points. See **Figure 99**.
5. Press **ENTER** to proceed to the third screen. This screen shows calibration temperature and temperature compensation mode. See **Figure 100**.
6. Press **ENTER** to proceed to the fourth screen. This screen shows current pH offset value in mV. See **Figure 101**.
7. Press **ENTER** to proceed to the fifth screen. This screen shows current acid slope 1 and 2. See **Figure 102**.
8. Press **ENTER** to proceed to the sixth screen. This screen shows current acid slope 2 and alkaline slope 1.—See **Figure 103**.
9. Press **ENTER** to proceed to the seventh screen. This screen shows current alkaline slope 1 and 2.—See **Figure 104**.
10. Press **ENTER** to return to the setup mode. Press Δ /MI to continue to the next setup program, or press ∇ /MR to go to the previous program. Press **EXIT** to return to the pH measurement mode.

Note: While viewing calibration data, you may press **EXIT** at any time to return to the setup mode.

pH Cal Data	:P1.6
Press ENT.	to Select

Figure 97

pH Cal Date / Time
Jan 22 2002 09:01:46

Figure 98

USA:	1.680	4.010
	7.000	10.010 12.450

Figure 99

pH Cal Temp =	25.3°C
Compensation =	ATC

Figure 100

pH Offset =	0.2 mV
-------------	--------

Figure 101

Acid Slope1 =	100.0 %
Acid Slope2 =	99.7 %

Figure 102

Acid Slope2 =	99.7 %
Alk. Slope1 =	99.7 %

Figure 103

Alk. Slope1 =	99.7 %
Alk. Slope2 =	98.2 %

Figure 104

pH Cal Reset :P1.7
Press ENT. to Select

Figure 105

pH Reset: Yes — No
Select & Press ENTER

Figure 106

pH being Reset
Please wait...

Figure 107

Reset Aborted

Figure 108

10.2.9 pH calibration data reset setup program P1.7

Use this program to erase all pH calibration data.

1. Enter pH/Temperature setup mode as described in steps 1-4 in Section 10.2.1 *Entering pH/temperature setup mode* (page 30).
2. Press Δ/MI to scroll to program *pH Cal Reset: P1.7*. See **Figure 105**.
3. Press **ENTER** to enter program *pH Cal Reset: P1.7*.
4. Press **>/CAL** to toggle between pH Reset: Yes and No. The selection will flash. See **Figure 106**.
5. Press **ENTER** to confirm selection.
 - If you selected **Yes**, the screen flashes *pH being Reset, Please wait...* See **Figure 107**. The meter then returns to setup mode.
 - If you select **No**, the screen flashes *Reset Aborted* and then returns to the setup mode. See **Figure 108**.

This is the last pH setup program. Press ∇/MR to go to the previous program. Press Δ/MI to go back to the first pH setup program. Press **EXIT** to return to the pH measurement mode.

10.3 mV setup mode

10.3.1 Entering mV setup mode

1. Turn the meter **ON**. If the meter is not in the mV measurement mode, press **EXIT** and use **>/CAL** to select mV. The mode selected will flash. Press **ENTER** to confirm selection. Their meter is now in mV measurement mode.
2. Press **SETUP** to enter the setup mode. The display will flash *Setup Mode Activated, Please wait...* See **Figure 109**.
3. Press **>/CAL** to select mV. The mode selected will flash. See **Figure 110**. Press **ENTER** to enter mV setup mode. You are now in the mV setup mode.
4. The first setup program in mV mode is *mV Meas. Alarm: P2.0*. See **Figure 111**. If you want to skip to another program, use the **Δ/MI** and **∇/MR** keys to scroll to the desired program.
5. To exit the setup mode at anytime, press **EXIT**. The meter returns to the mV measurement mode.



Figure 109

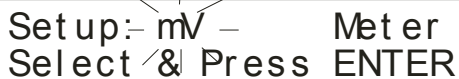

Figure 110

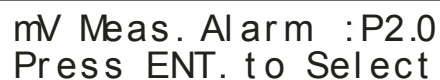

Figure 111

NOTE: To exit the setup mode at anytime without confirming changes, press **EXIT**. If you have made any changes to any programs and press **EXIT**, these changes will be confirmed. To reset meter to default factory settings, see setup program *Meter Reset P4.7* (page 54).

10.3.2 mV measurement alarm setup program P2.0

Use this program to select alarm for low and high mV measurements.

1. Enter mV setup mode as described in steps 1-4 in *Section 10.3.1 Entering mV setup mode* (page 37). The first setup mode is *mV Meas. Alarm: P2.0*. See **Figure 112**.
2. Press **ENTER** to enter program *mV Meas. Alarm: P2.0*.
3. Press **>/CAL** to toggle between mV Alarm *On* and *Off*. The selection will flash. See **Figure 113**.
4. Press **ENTER** to confirm selection.
 - If you selected **On**, continue to step 5.
 - If you select **Off**, pressing **ENTER** returns to the setup mode.

To continue to the next setup program, press **Δ/MI**.
To continue to the previous program, press **∇/MR**.
Press **EXIT** to return to the mV measurement mode.

5. If you selected **On** in step 4, the display now reads *Key in Low Alarm mV Set Point*. Key in the low mV alarm set point using the numeric keypad, using the “-” key for negative numbers. See **Figure 114**. If you make a mistake, use the **Δ/MI** or **∇/MR** to highlight mistake, then re-enter. Press **ENTER** to confirm value.
6. The display now reads *Key in High Alarm mV Set Point*. The high alarm setting must be at least 100.0 mV greater than low alarm. Key in the high mV alarm set point using the numeric keypad, using the “-” key for negative numbers. See **Figure 115**. If you make a mistake, use the **Δ/MI** or **∇/MR** to highlight mistake, then re-enter. Press **ENTER** to confirm value.
7. Press **ENTER** to confirm mV set point values. The screens flashes *Sys Updating, Please wait...* and returns to the setup mode. To continue to the next setup program, press **Δ/MI**. To continue to the previous program, press **∇/MR**. Press **EXIT** to return to mV measurement mode.

mV Meas. Alarm : P2.0
Press ENT. to Select

Figure 112

mV Alarm - On - Off
Select & Press ENTER

Figure 113

Key In Low Alarm
mV Set Point: -1550.0

Figure 114

Key In High Alarm
mV Set Point: 1550.0

Figure 115

10.3.3 mV calibration due alarm setup program P2.1

Use this program to set a reminder when the next calibration is due. Choose from 1 to 365 days from last calibration.

1. Enter mV setup mode as described in steps 1-4 in *Section 10.3.1 Entering mV setup mode* (page 37).
2. Use Δ/MI key to scroll to program *mVCalDue Alarm: P2.1*. See **Figure 116**.
3. Press **ENTER** to enter program *mVCalDue Alarm: P2.1*.
4. Press $>/CAL$ to toggle between Cal Alarm Due: *On* and *Off*. The selection will flash. See **Figure 117**.
5. Press **ENTER** to confirm selection.
 - If you selected **On**, continue to step 6.
 - If you select **Off**, pressing **ENTER** returns to the setup mode.

Press Δ/MI to continue to the next setup program, or press ∇/MR to go to the previous program. Press **EXIT** to return to mV measurement mode.

6. If you selected **On** in step 5, the display reads *Key in Cal Due Period (1-365 days) =*. Key number of days using the numeric keypad. If you make a mistake, use the Δ/MI or ∇/MR keys to highlight mistake, then re-enter. See **Figure 118**.
7. Press **ENTER** to confirm number of days to next calibration, screen flashes *Sys Updating, Please wait...* and returns to the setup mode.

Press Δ/MI to continue to the next setup program, or press ∇/MR to go to the previous program. Press **EXIT** to return to mV measurement mode.

mVCalDue Alarm :P2.1
Press ENT. to Select

Figure 116

Cal Alarm Due On-Off
Select & Press ENTER

Figure 117

Keyin Cal Due Period
(1-365 days) = 1

Figure 118

10.3.4 Stability setup program P2.2

Use this program to turn on or off the mV stability indicator and to set level of stability (low, medium or high).

Stability definitions

High stability:

reading is stabilized quickly, but reading is less accurate.

Medium stability:

reading stability is averaged between high and low stability.

Low stability:

reading is stabilized slowly, but guarantees high accuracy

1. Enter mV setup mode as described in steps 1-4 in *Section 10.3.1 Entering mV setup mode* (page 37).
2. Use Δ/MI key to scroll to program *Stability Setup: P2.2*. See **Figure 119**.
3. Press **ENTER** to enter program *Stability Setup: P2.2*.
4. Press **>/CAL** to toggle between mV Stable Criteria: *On* and *Off*. The selection will flash. See **Figure 120**.
5. Press **ENTER** to confirm selection.
 - If you selected **On**, continue to step 6.
 - If you select **Off**, pressing **ENTER** returns to the setup mode.

Press Δ/MI key to continue to the next setup program, or press ∇/MR to go to the previous program. Press **EXIT** to return to the mV measurement mode.

6. If you selected **On** in step 5, the display now reads *Degree of Stability: Low Medium High*. Press **>/CAL** to toggle between *Low*, *Medium* and *High*. The selection will flash. See **Figure 121**.
7. Press **ENTER** to confirm selection and return to the setup mode. Press Δ/MI to continue to the next setup program, or press ∇/MR to go to the previous program. Press **EXIT** to return to the pH measurement mode.



Figure 119



Figure 120



Figure 121

10.3.5 View mV calibration data setup program P2.3

Use this program to view the following:

- Last mV calibration date/time
- mV offset value

1. Enter mV setup mode as described in steps 1-4 in *Section 10.3.1 Entering mV setup mode* (page 37).
2. Use Δ/MI to scroll to program *mV Cal Data: P2.3*. See **Figure 122**.
3. Press **ENTER** to enter program *mV Cal Data: P2.3*. The first screen in *mV Cal Data: P2.3* is the mV Cal Date/Time. See **Figure 123**.
4. Press **ENTER** to proceed to the second screen. This screen shows current mV offset value. See **Figure 124**.
5. Press **ENTER** to return to the setup mode.
Press Δ/MI to continue to the next setup program, or press ∇/MR to go to the previous program. Press **EXIT** to return to mV measurement mode.

Note: While viewing calibration data, you may press **EXIT** at any time to return to the setup mode.



mV Cal Data :P2.3
Press ENT. to Select

Figure 122



mV Cal Date/ Time
Jan 22 2002 11:55:08

Figure 123

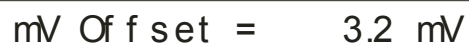

mV Of f set = 3.2 mV

Figure 124

10.3.6 mV calibration data reset setup program P2.4

Use this program to erase all mV calibration data.

1. Enter mV setup mode as described in steps 1-4 in *Section 10.3.1 Entering mV setup mode* (page 37).
2. Use Δ/MI key to scroll to program *mV Cal Reset: P2.4*. See **Figure 125**.
3. Press **ENTER** to enter program *mV Cal Reset: P2.4*.
4. Press $>/CAL$ key to toggle between *mV Reset: Yes* and *No*. The selection will flash. See **Figure 126**.
5. Press **ENTER** to confirm selection.
 - If you selected **Yes**, the screen flashes *mV being Reset, Please wait...* See **Figure 127**. The meter then returns to setup mode.
 - If you select **No**, the screen flashes *Reset Aborted* and then returns to the setup mode. See **Figure 128**. This is the last mV setup program. Press ∇/MR to go to the previous program. Press Δ/MI to go back to the first mV setup program. Press **EXIT** to return to mV measurement mode.

mV Cal Reset :P2.4
Press ENT. to Select

Figure 125

mV Reset: Yes No
Select & Press ENTER

Figure 126

mV being Reset
Please wait...

Figure 127

Reset Aborted

Figure 128

10.4 Ion setup mode (pH 2100 meter only)

10.4.1 Entering ion setup mode

1. Turn the meter **ON**. If the meter is not in ion measurement mode, press **EXIT** and use **>/CAL** key to select ion. The mode selected will flash. Press **ENTER** to confirm selection. The meter is now in Ion measurement mode.
2. Press **SETUP** to enter the setup mode. The display will flash *Setup Mode Activated, Please wait...* See **Figure 129**.
3. Use **>/CAL** key to select ion. See **Figure 130**. The mode selected will flash. Press **ENTER** to enter Ion setup mode. You are now in the Ion setup mode.
4. The first setup program in Ion mode is *Ion Unit Setup: P3.0*. See **Figure 131**. If you want to skip to another program, use the **Δ/MI** and **∇/MR** keys to scroll to the desired program.
5. To exit the setup mode at anytime, press **EXIT**. The meter returns to the ion measurement mode.

NOTE: To exit the setup mode at anytime without confirming changes, press **EXIT**. If you have made any changes to any programs and press **EXIT**, these changes will be confirmed. To reset meter to default factory settings, see setup program *Meter Reset P4.7* (page 54).

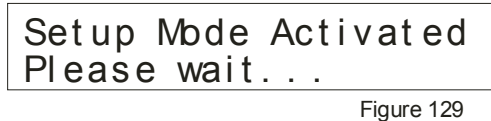

Figure 129

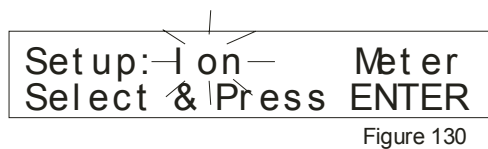

Figure 130

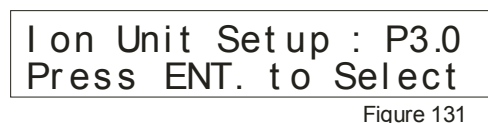

Figure 131

10.4.2 Ion unit setup mode P3.0

Use this program to select Ion measurement units: ppm, ppt, mg/L, g/L, mmol/L, or mol/L

1. Enter ion setup mode as described in above in *Section 10.4.1 Entering ion setup mode*. The first setup mode is *Ion Unit Setup: P3.0* See **Figure 132**.
2. Press **ENTER** to enter program *Ion Unit Setup: P3.0*. Press **>/CAL** key to toggle between *ppm*, *ppt*, *mg/l*, *g/l*, *mmol/l* or *mol/l*. The unit selected will flash. See **Figure 133**.
3. Press **ENTER** to confirm selection and return to the setup mode. To continue to the next setup program, press **Δ/MI**. To continue to the previous program press **∇/MR**. Press **EXIT** to return to the ion measurement mode.



Figure 132

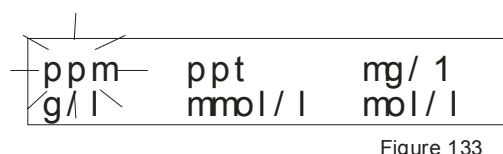

Figure 133

10.4.3 Ion measurement alarm setup program P3.1

Use this program to select alarm for low and high ion measurements.

1. Enter ion setup mode as described in steps 1-4 in *Section 10.4.1 Entering ion setup mode* (page 43).
2. Use Δ/MI key to scroll to program *Ion Meas. Alarm: P3.1*. See **Figure 134**.
3. Press $>/CAL$ key to toggle between ion alarm *On* and *Off*. The selection will flash. See **Figure 135**.
4. Press **ENTER** to confirm selection.
 - If you selected **On**, continue to step 5.
 - If you select **Off**, pressing **ENTER** returns to the setup mode.

To continue to the next setup program, press Δ/MI .
 To continue to the previous program, press ∇/MR .
 Press **EXIT** to return to the ion measurement mode.

5. If you selected **On** in step 4, the display now reads *Key in Low Alarm Ion Set Point*. Key in the low ion alarm set point using the numeric keypad. See **Figure 136**. If you make a mistake, use the Δ/MI or ∇/MR to highlight mistake, then re-enter. Press **ENTER** to confirm value.
6. The display now reads *Key in High Alarm Ion Set Point*. The high alarm setting must be at least one-half decade greater than the low alarm. Key in the high ion alarm set point using the numeric keypad. See **Figure 137**. If you make a mistake, use the Δ/MI or ∇/MR to highlight mistake, then re-enter. Press **ENTER** to confirm value.
7. Press **ENTER** to confirm ion set point values. The screens flashes *Sys Updating, Please wait...* and returns to the setup mode. To continue to the next setup program, press Δ/MI . To continue to the previous program, press ∇/MR . Press **EXIT** to return to mV measurement mode.



Figure 134



Figure 135



Figure 136



Figure 137

10.4.4 Ion calibration due alarm setup program P3.2

Use this program to set a reminder when the next calibration is due. Choose from 1 to 365 days from last calibration.

1. Enter ion setup mode as described in steps 1-4 in *Section 10.4.1 Entering ion setup mode* (page 43).
2. Use Δ/MI key to scroll to program *IonCalDue Alarm: P3.2*. See **Figure 138**.
3. Press **ENTER** to enter program *IonCalDue Alarm: P3.2*.
4. Press $>/CAL$ key to toggle between **Cal Alarm Due: On** and **Off**. The selection will flash. See **Figure 139**.
5. Press **ENTER** to confirm selection.
 - If you selected **On**, continue to step 6.
 - If you select **Off**, pressing **ENTER** returns to the setup mode.

Press Δ/MI key to continue to the next setup program, or press ∇/MR to go to the previous program. Press **EXIT** to return to mV measurement mode.

6. If you selected On in step 5, the display reads *Key in Cal Due Period (1-365 days) = 1*. Key number of days using the numeric keypad. If you make a mistake, use Δ/MI or ∇/MR keys to highlight mistake, then re-enter. See **Figure 140**.
7. Press **ENTER** to confirm number of days to next calibration; screen flashes *Sys Updating, Please wait...* and returns to the setup mode. Press Δ/MI key to continue to the next setup program, or press ∇/MR to go to the previous program. Press **EXIT** to return to mV measurement mode.



Figure 138



Figure 139

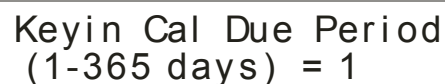

Figure 140

10.4.5 Stability setup program P3.3

Use this program to turn on or off the ion stability indicator and to set level of stability (low, medium or high).

Stability definitions

High stability:

Reading is stabilized quickly, but reading is less accurate.

Medium stability:

Reading stability is averaged between high and low stability.

Low stability:

Reading is stabilized slowly, but guarantees high accuracy.

1. Enter ion setup mode as described in steps 1-4 in *Section 10.4.1 Entering ion setup mode* (page 43).
2. Use Δ/MI key to scroll to program *Stability Setup: P3.3* See **Figure 141**.
3. Press **ENTER** to enter program *Stability Setup: P3.3*
4. Press $>/CAL$ key to toggle between *Ion Stable Criteria: On* and *Off*. The selection will flash. See **Figure 142**.
5. Press **ENTER** to confirm selection.
 - If you selected **On**, continue to step 6.
 - If you select **Off**, pressing **ENTER** returns to the setup mode.

Press Δ/MI key to continue to the next setup program, or Press ∇/MR to go to the previous program. Press **EXIT** to return to the ion measurement mode.

6. If you selected **On** in step 5, the display now reads *Degree of Stability: Low Medium High*. Press $>/CAL$ to toggle between **Low**, **Medium** and **High**. The selection will flash. See **Figure 143**.
7. Press **ENTER** to confirm selection and return to the setup mode. Press Δ/MI key to continue to the next setup program, or press ∇/MR to go to the previous program. Press **EXIT** to return to the ion measurement mode.



Figure 141

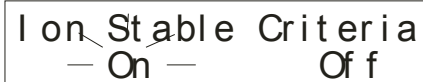

Figure 142



Figure 143

10.4.6 Ion mode setup program P3.4

Use this program to select high or low ion resolution mode. High resolution has ± 500 mV value, low has ± 1850 mV value.

1. Enter ion setup mode as described in steps 1-4 in *Section 10.4.1 Entering ion setup mode* (page 43).
2. Use Δ /MI key to scroll to program *Ion Mode Setup: P3.4*. See **Figure 144**.
3. Press **ENTER** to enter program *Ion Mode Setup: P3.4*.
4. Press $>$ /CAL to toggle between **High** or **Low**. The unit selected will flash. See **Figure 145**.
5. Press **ENTER** to confirm selection and return to the setup mode.
6. Press Δ /MI key to continue to the next setup program, or press ∇ /MR to go to the previous program. Press **EXIT** to return to the ion measurement mode.



Ion Mode Setup: P3.4
Press ENT. to Select

Figure 144

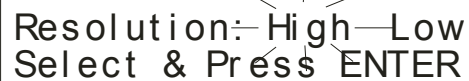

Resolution: High—Low
Select & Press ENTER

Figure 145

10.4.7 View ion calibration data setup program P3.5

Use this program to view the following:

- Last ion calibration date/time
- Calibration points with absolute mV values
- Ion slope values

1. Enter ion setup mode as described in steps 1-4 in *Section 10.4.1 Entering ion setup mode* (page 43).
2. Use Δ /MI key to scroll to program *Ion Cal Data: P3.5*. See **Figure 146**.
3. Press **ENTER** to enter program *Ion Cal Data: P3.5*. The first screen in *Ion Cal Data: P3.5* is the Ion Cal Date/Time. See **Figure 147**.
4. Press **ENTER** to proceed to the second screen, showing 1st and 2nd ion calibration points and corresponding absolute mV value. See **Figure 148**.
5. Press **ENTER** to proceed to the third screen, showing 2nd and 3rd ion calibration points and corresponding absolute mV value. See **Figure 149**.
6. Press **ENTER** to proceed to the fourth screen, showing 3rd and 4th ion calibration points and corresponding absolute mV value. See **Figure 150**.
7. Press **ENTER** to proceed to the fifth screen, showing 4th and 5th ion calibration points and corresponding absolute mV value. See **Figure 151**.
8. Press **ENTER** to proceed to the sixth screen, showing Ion Slope 1 and 2 mV value. See **Figure 152**.
9. Press **ENTER** to proceed to the seventh screen, showing Ion Slope 2 and 3 mV value. See **Figure 153**.
10. Press **ENTER** to proceed to the eighth screen, showing Ion Slope 3 and 4 mV value. See **Figure 154**.
Press Δ /MI key to continue to the next setup program, or Press ∇ /MR to go to the previous program. Press **EXIT** to return to ion measurement mode.

NOTE: While viewing calibration data, you may press **EXIT** at any time to return to the setup mode.

```

Ion Cal Data :P3.5
Press ENT. to Select
    
```

Figure 146

```

Ion Cal Date/ Time
Jan 22 2002 14:55:38
    
```

Figure 147

```

1st :0.001 → 0.6 mV
2nd:0.010 → 50.1 mV
    
```

Figure 148

```

2nd:0.010 → 50.1 mV
3rd:0.100 → 100.8 mV
    
```

Figure 149

```

3rd:0.100 → 100.8 mV
4th: 1.00 → 149.4 mV
    
```

Figure 150

```

4th: 1.00 → 149.4 mV
5th: 10.0 → 201.0 mV
    
```

Figure 151

```

Ion Slope1 = 49.5 mV
Ion Slope2 = 50.6 mV
    
```

Figure 152

```

Ion Slope2 = 50.6 mV
Ion Slope3 = 48.6 mV
    
```

Figure 153

```

Ion Slope3 = 48.6 mV
Ion Slope4 = 51.5 mV
    
```

Figure 154

10.4.8 Ion calibration data reset setup program P3.6

Use this program to erase all ion calibration data.

1. Enter ion setup mode as described in steps 1-4 in *Section 10.4.1 Entering ion setup mode* (page 43).
2. Use Δ/MI key to scroll to program *Ion Cal Reset: P3.6*. See **Figure 155**.
3. Press **ENTER** to enter program *Ion Cal Reset: P3.6*.
4. Press $>/CAL$ key to toggle between **Ion Reset: Yes** and **No**. The selection will flash. See **Figure 156**.
5. Press **ENTER** to confirm selection.
 - If you selected **Yes**, the screen flashes *Ion being Reset, Please wait...* See **Figure 157**. The meter then returns to setup mode.
 - If you select **No**, the screen flashes *Reset Aborted* and then returns to the setup mode. See **Figure 158**.

This is the last ion setup program. Press ∇/MR to go to the previous program. Press Δ/MI to go back to the first ion setup program. Press **EXIT** to return to mV measurement mode.



Figure 155



Figure 156

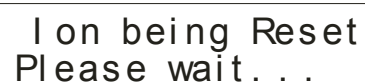

Figure 157



Figure 158

10.5 Meter general configuration setup mode

10.5.1 Entering meter general setup mode

1. Turn the meter **ON**. The meter setup mode can be entered from any measurement mode—pH, mV or ion (pH 2100 meter only).
2. Press **SETUP** to enter the setup mode. The display will flash *Setup Mode Activated, Please wait. .*See **Figure 159**.
3. Use **>/CAL** to select "Meter". The mode selected will flash. See **Figure 160, 161 and 162**. Press **ENTER** to enter Meter setup mode. You are now in the Meter setup mode.
4. The first setup program in Ion mode is *Date/Time Setup: P4.0*. See **Figure 163**. If you want to skip to another program, use the **Δ/MI** and **∇/MR** keys to scroll to the desired program.
5. To exit the setup mode at anytime, press **EXIT**. The meter returns to the measurement mode that it was in prior to entering meter setup mode.

NOTE: To exit the setup mode at anytime without confirming changes, press **EXIT**. If you have made any changes to any programs and press **EXIT**, these changes will be confirmed. To reset meter to default factory settings, see setup program *Meter Reset P4.7* (page 54).

10.5.2 Date/time setup mode P4.0

Use this program to set the meter date and time.

1. Enter the Meter setup mode as described above in *Section 10.5.1 Entering meter general setup mode* (Pg 50). The first setup mode is *Date/Time Setup: P4.0*. See **Figure 163**.
2. Press **ENTER** to enter program *Date/Time Setup: P4.0*.
3. Key in the Date, Month, Year, Hr and Min using the numeric keypad. Use the **>/CAL** key or the **ENTER** key to toggle to each field. If you make a mistake keying the value, use the **Δ/MI** and **∇/MR** keys to highlight mistake, then re-enter. See **Figure 164**.
4. After keying in a value for the last field (Min), press **ENTER** to confirm. The screen flashes *Clock Updating, Please wait. .* See **Figure 165**. The clock then flashes the date and time.

See **Figure 166**.

Press **Δ/MI** key to continue to the next setup program, or press **∇/MR** to go to the previous program. Press **EXIT** to return to the measurement mode you were in prior to entering meter setup mode.



Setup Mode Activated
Please wait. . .

Figure 159



Setup: pH/ Temp - Meter
Select & Press ENTER

Figure 160



Setup: mV - Meter
Select & Press ENTER

Figure 161



Setup: Ion - Meter
Select & Press ENTER

Figure 162



Date/ Time Setup: P4.0
Press ENT. to Select

Figure 163



Date: 23 Month: 01
Year: 02 Hr: 8 Mn: 07

Figure 164



Clock Updating
Please wait. . .

Figure 165



Date Time
Jan 23 2002 08:07:31

Figure 166

10.5.3 Backlight setup mode P4.1

Use this program to turn backlight on or off and set duration time (0.1 to 10 minutes).

1. Enter meter setup mode as described in steps 1-4 in *Section 10.5.1 Entering meter setup mode* (page 50).
2. Use Δ/MI key to scroll to program *Backlight Setup: P4.1*. See **Figure 167**.
3. Press **ENTER** to enter program *Backlight Setup: P4.1*.
4. Press $>/CAL$ key to toggle between **Backlight On** and **Off**. The selection will flash. See **Figure 168**.
5. Press **ENTER** to confirm selection.
 - If you selected **On**, continue to step 6.
 - If you select **Off**, pressing **ENTER** returns to the setup mode.

Press Δ/MI to continue to the next setup program, or press ∇/MR to go to the previous program. Press **EXIT** to return to measurement mode.

6. If you selected On in step 5, the display now reads *Key BL On Period, (0.1-10.0 min) =2.00*. See **Figure 169**. Key in the backlight on period using the numeric keypad. If you make a mistake, use Δ/MI or ∇/MR keys to highlight mistake, then re-enter .
7. Press **ENTER** to confirm selection. The screen flashes *Sys Updating... Please wait...* and then returns to the setup mode. Press Δ/MI key to continue to the next setup program, or press ∇/MR to go to the previous program. Press **EXIT** to return to measurement mode.

BackLight Setup:P4.1
Press ENT. to Select

Figure 167

BackLight On - Off
Select & Press ENTER

Figure 168

Key BL ON Period
(0.1-10.0 min) =2.00

Figure 169

10.5.4 Data log setup mode P4.2

Use this program select automatic or manual data logging. Automatic data logging can be set at timed intervals from 10 seconds to 23 hours, 59 minutes, 59 seconds.

1. Enter meter setup mode as described in steps 1-4 in *Section 10.5.1 Entering meter setup mode* (page 50).
2. Use Δ/MI key to scroll to program *Data Log Setup: P4.2*. See **Figure 170**.
3. Press **ENTER** to enter program *Data Log Setup: P4.2*.
4. Press $>/CAL$ key to toggle between **Data Log Auto** and **Manual**. The selection will flash. See **Figure 171**.
5. Press **ENTER** to confirm selection.
 - If you selected Auto, continue to step 6.
 - If you select Manual, pressing **ENTER** returns to the setup mode. Press Δ/MI key to continue to the next setup program, or press ∇/MR to go to the previous program.

Press **EXIT** to return to measurement mode.

6. If you selected Auto in step 5, the display now reads **Auto DataLog Period Hr: Min: Sec** : Key in the time period (minimum of 10 seconds to maximum of 23 hours, 59 minutes, 59 seconds) using the numeric keypad. If you make a mistake, use Δ/MI or ∇/MR keys to highlight mistake, then re-enter. See **Figure 172**.
7. Press **ENTER** to confirm selection. The screen flashes *Sys Updating... Please wait...* and then returns to the setup mode. Press Δ/MI key to continue to the next setup program, or press ∇/MR to go to the previous program. Press **EXIT** to return to measurement mode.

10.5.5 Memory recall setup mode P4.3

Use this program to select automatic or manual memory recall. See page 24 for more information on memory recall.

1. Enter meter setup mode as described in steps 1-4 in *Section 10.5.1 Entering meter setup mode* (page 50).
2. Use Δ/MI key to scroll to program *MemRecall Setup: P4.3*. See **Figure 173**.
3. Press **ENTER** to enter program *MemRecall Setup: P4.3*.
4. Press $>/CAL$ key to toggle between **Memory Recall Mode Auto** and **Manual**. The selection will flash. See **Figure 174**.
5. Press **ENTER** to confirm selection and return to the setup mode. Press Δ/MI key to continue to the next setup program, or press ∇/MR to go to the previous program. Press **EXIT** to return to measurement mode.

Data Log Setup :P4.2
Press ENT. to Select

Figure 170

Data Log:Auto-
Select & Press ENTER-
Manual-

Figure 171

Auto DataLog Period
Hr:1 Mn:30 Sec:0

Figure 172

MemRecall Setup:P4.3
Press ENT. to Select

Figure 173

Memory Recall Mode
Auto - Manual-

Figure 174

10.5.6 Communication setup mode P4.4

Use this program to set parameters of serial communication.

1. Enter meter setup mode as described in steps 1-4 in *Section 10.5.1 Entering meter setup mode* (page 50).
2. Use Δ/MI key to scroll to program *Tx/Rx Parameter: P4.4*. See **Figure 175**.
3. Press **ENTER** to enter program *Tx/Rx Parameter: P4.4*.
4. Press $>/CAL$ key to toggle between **Baud Rate 4800, 9600 and 19200**. The selection will flash. See **Figure 176**. Press **ENTER** to confirm selection and go to the next setup screen.
5. Press $>/CAL$ key to toggle between **Stop Bit One and Two**. The selection will flash. See **Figure 177**. Press **ENTER** to confirm selection and go to the next setup screen.
6. Press $>/CAL$ key to toggle between **Parity Bit None, Odd and Even**. The selection will flash. See **Figure 178**.
7. Press **ENTER** to confirm selection and return to the setup mode. Press Δ/MI key to continue to the next setup program, or press ∇/MR to go to the previous program. Press **EXIT** to return to measurement mode.



Figure 175

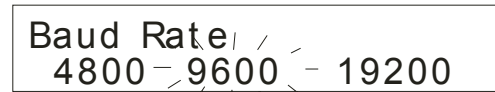

Figure 176

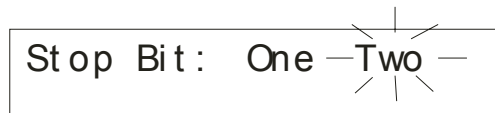

Figure 177



Figure 178

10.5.7 Data transfer setup mode P4.5

1. This program lets you select what data is sent to your printer or computer.
2. Enter meter setup mode as described in steps 1-4 in *Section 10.5.1 Entering meter setup mode* (page 50).
3. Use Δ/MI key to scroll to program *Data Transfer: P4.5*. See **Figure 179**.
4. Press **ENTER** to enter program *Data Transfer: P4.5*.
5. Press $>/CAL$ key to toggle between Data send to printer **Current** and **Memory**. The selection will flash. See **Figure 180**.
6. Press **ENTER** to confirm selection and return to the setup mode. Press Δ/MI key to continue to the next setup program, or press ∇/MR to go to the previous program. Press **EXIT** to return to measurement mode.



Figure 179



Figure 180

10.5.8 Memory clear setup mode P4.6

Clears all pH, mV and Ion (pH2100 only) memory points stored in memory.

1. Enter meter setup mode as described in steps 1-4 in *Section 10.5.1 Entering meter setup mode* (page 50).
2. Use Δ/MI key to scroll to program *Mem Clear Setup: P4.6*. See **Figure 181**.
3. Press **ENTER** to enter program *Mem Clear Setup: P4.6*.
4. Press $>/CAL$ key to toggle between **Memory Clear Yes** and **No**. The selection will flash. See **Figure 182**.
5. Press **ENTER** to confirm selection.
 - If you select **Yes**, the screen flashes *Memory being Cleared, Please wait...* See **Figure 183**. The meter then returns to the setup mode.
 - If you select **No**, the meter returns to the setup mode. Press Δ/MI to continue to the next setup program, or press ∇/MR to go to the previous program. Press **EXIT** to return to measurement mode.



Figure 181



Figure 182

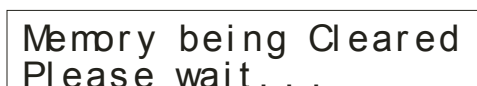

Figure 183

10.5.9 Meter reset setup mode P4.7

Resets the meter to factory default settings:

- pH/mV/Ion* calibration data is erased
- Manual temperature compensation is set to 25.0°C
- pH/mV/Ion* measurement alarm is off
- pH/mV/Ion* calibration due alarm is off
- Stability indicator is turned on with low stability setting
- Data logging and memory recall has manual setting
- Backlight is on with 2.0 minute duration
- Memory is cleared

*Ion features on the CyberScan pH2100 meter only

1. Enter meter setup mode as described in steps 1-4 in *Section 10.5.1 Entering meter setup mode* (page 50).
2. Use Δ/MI key to scroll to program *Meter Reset: P4.7*. See **Figure 184**.
3. Press **ENTER** to enter program *Meter Reset: P4.7*.
4. Press $>/CAL$ key to toggle between **Meter Reset Yes** and **No**. The selection will flash. See **Figure 185**.
5. Press **ENTER** to confirm selection.
 - If you selected **Yes**, the screen flashes *Meter being Reset, Please wait...* See **Figure 186**. The meter then returns to measurement mode.
 - If you select **No**, the screen flashes *Reset Aborted*. See **Figure 187**. The meter then returns to the measurement mode.



Figure 184



Figure 185

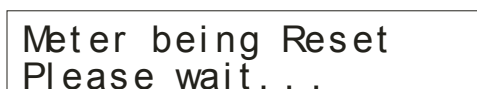

Figure 186



Figure 187

11 ELECTRODE CARE

11.1 Electrode Activation

DO NOT touch or rub the glass bulb. If you follow the storage and maintenance procedure, you can use your electrode immediately. If the electrode responds sluggishly or drifts, the bulb may be dehydrated. Immerse the electrode in an ideal storage solution such as electrode storage solution or pH 4 buffer solution for 1-2 hours to hydrate it. See **Storing pH/ORP electrodes** below.

If this procedure does not hydrate the electrode, reactivate or replace it.

Use 2 or 3 point calibration to test your electrode performance. If you do not get good readings, use a different pH electrode to confirm the meter is working properly. If the results are still not satisfactory, consult your distributor/dealer.

11.2 Electrode Maintenance

pH electrodes are susceptible to dirt, dehydration and contamination. Clean them regularly depending on the extent and condition of use.

11.3 Storing pH/ORP electrodes

For best results, always keep the bulb wet, preferably in pH storage solution. Other pH buffers or tap water are also acceptable. Do not store in de-ionized water. Eutech Instruments/ Oakton Instruments offers a complete range of electrode storage and cleaning solutions.

After Use

1. After each series of measurements, wash the electrode and reference junction in de-ionized water.
2. If using a refillable electrode, close the refilling hole by placing its rubber sleeve or stopper plug into its position.
3. Store the electrode as mentioned above.

Electrode Cleaning

Electrodes that are mechanically intact can often be restored to normal performance by one or a combination of the following options.

Some suggestions for:

a. Salt deposits which are normal on all electrodes

Dissolve the deposit by immersing the electrode in tap water for 10 to 15 minutes. Thoroughly rinse with de-ionized water.

b. General dirt and protein coatings

Soak the electrode for several hours in the general-purpose electrode cleaning solutions. Rinse in de-ionized or tap water.

c. Oil/Grease Films

Wash the electrode pH bulb in a little dish washing detergent and water. Rinse the electrode tip with de-ionized water.

d. Clogged reference junction.

Heat a dilute 1% KCl solution or pH 4.01 buffer solution to 60-80°C. Place the sensing portion of the pH electrode into the heated KCl solution for approximately 30 minutes. Allow the electrode to cool while immersed in some unheated KCl solution or pH 4.01 buffer solution. Rinse with deionized water.

12 RS 232 COMMUNICATION

This meter will send data to a printer and computer through the RS-232 port located on the back panel of the meter. See **Figure 188**. This meter uses a 9 pin serial connection for RS-232 communication.

12.1 Using with printer

If you are going to use your meter to send data to a printer, you must first configure your meter to match the settings for your printer (consult printer manual for proper printer operation). See *Meter Setup mode P4.4 Tx/Rx Parameter* (page 53) to set baud rate, stop bit and parity for your meter.

12.1.1 Sending data to printer

You can either send current data or data stored in memory to your printer. See *Meter Setup mode Program P4.5 Data Transfer* (page 53) to select which data is sent to your printer.

1. Connect your meter to printer (consult printer manual for cable connections). Use a 9 pin serial connection for pH 1100 and pH 2100).
2. To send data to your printer, press the **PRINT** key on the meter.

12.2 Using with computer

Use the RS-232 cable to connect your meter to a computer. Refer to enclosed software disc for instructions on how to use software with your meter.

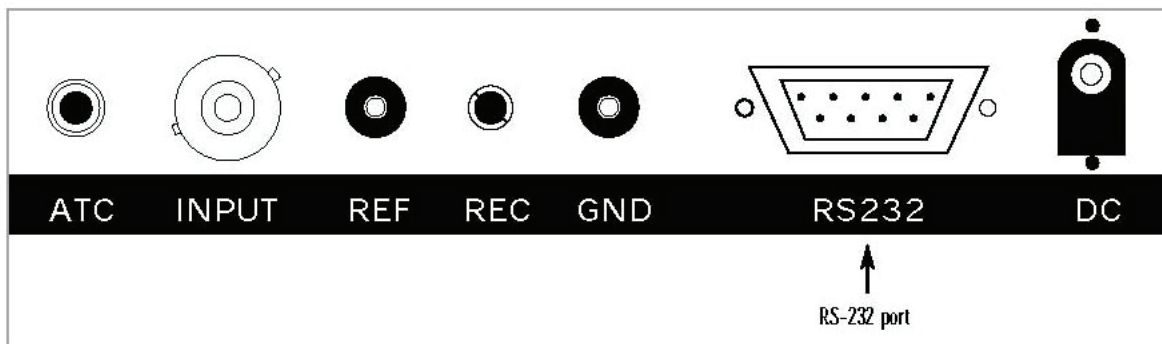

Figure 188: Back Panel of Meter

13 ADDITIONAL INFORMATION

13.1 pH and Temperature

The pH electrode is affected by temperature changes. Automatic Temperature Compensation (ATC) compensates for these temperature changes. Some solutions show an increase while others a decrease in pH with the same temperature change. Record the solution temperature along with the pH value, or the measurement may be meaningless.

Temperature changes also affect the signal the pH electrode sends to the meter and causes a loss of accuracy for the reading. To limit the loss of accuracy during calibration, make the temperature of the pH buffer calibrating solutions and the sample solution the same.

13.2 pH Buffer Calibration Solution

You can use standard buffer solutions to calibrate a pH meter before you measure the pH of a sample. Calibration solutions serve as basis of comparison between measurements. The most common standard buffers are pH 4.01, pH 7.00 and pH 10.01.

For 1-point calibration, use a standard buffer of pH 7.00 or 6.86, or a standard or custom buffer whose pH value is close to that of the sample. Use 2-point calibration when you know the sample is acidic (low pH) or basic (high pH). For example: in acidic samples, use standard buffers such as pH 7.00 and pH 4.01; in basic samples, use standards such as pH 7.00 and pH 10.01.

Use multi-point calibration when the sample pH is completely unknown or for best accuracy over the entire pH range. Contact your distributor for information on pH buffer and calibration solutions.

13.3 Standard pH Buffers

The following table shows the various pH values at different temperature of the solution during calibration. The table also illustrates why a calibration value may be different from the buffer value at 25°C.

Temperature (°C)	USA Buffer					NIST Buffer				
	1.68	4.01	7.00	10.01	12.45	1.68	4.01	6.86	9.18	12.45
0	1.67	4.01	7.12	10.32	13.43	1.67	4.01	6.98	9.46	13.43
5	1.67	4.01	7.09	10.25	13.21	1.67	4.01	6.95	9.40	13.21
10	1.67	4.01	7.06	10.18	13.00	1.67	4.01	6.92	9.33	13.00
15	1.67	4.00	7.04	10.12	12.81	1.67	4.00	6.90	9.28	12.81
20	1.68	4.00	7.02	10.06	12.63	1.68	4.00	6.87	9.23	12.63
25	1.68	4.01	7.00	10.01	12.45	1.68	4.01	6.86	9.18	12.45
30	1.69	4.01	6.99	9.97	12.29	1.69	4.01	6.85	9.14	12.29
35	1.69	4.02	6.98	9.93	12.13	1.69	4.02	6.84	9.11	12.13
40	1.70	4.03	6.97	9.93	11.99	1.70	4.03	6.84	9.07	11.99
45	1.70	4.04	6.97	9.86	11.84	1.70	4.04	6.83	9.04	11.84
50	1.71	4.06	6.97	9.83	11.70	1.71	4.06	6.83	9.01	11.70
55	1.72	4.08	6.97	9.81	11.58	1.72	4.08	6.83	8.99	11.58
60	1.73	4.10	6.98	9.79	11.45	1.73	4.10	6.84	8.96	11.45
65	1.73	4.11	6.98	9.77	11.45	1.73	4.11	6.84	8.94	11.45
70	1.74	4.12	6.99	9.76	11.45	1.74	4.12	6.84	8.92	11.45
75	1.75	4.14	6.99	9.75	11.45	1.75	4.14	6.85	8.91	11.45
80	1.77	4.16	7.00	9.74	11.45	1.77	4.16	6.86	8.89	11.45
85	1.78	4.18	7.01	9.73	11.45	1.78	4.18	6.87	8.87	11.45
90	1.80	4.23	7.02	9.73	11.45	1.80	4.23	6.88	8.85	11.45
95	1.81	4.23	7.03	9.74	11.45	1.81	4.23	6.88	8.85	11.45
100	1.81	4.23	7.03	9.74	11.45	1.81	4.23	6.88	8.85	11.45
105	1.81	4.23	7.03	9.74	11.45	1.81	4.23	6.88	8.85	11.45

14 SUMMARY OF DEFAULT SETTINGS / OPTIONS

Program	Setup Menus	Options	Factory Defaults
pH SETUP Menu			
P1.0	pH Buffer Setup	USA, NIST, Bf1, Bf2, Custom	USA
P1.1	pH Resolution Setup	0.01, 0.001	0..001
P1.2	Temperature Unit Setup	°C, °F	°C
P1.3	pH Measurement Alarm	On, Off	Off
P1.4	pH Calibration Due Alarm	On, Off	Off
P1.5	Stability Setup	On, Off	On (Low)
P1.6	pH Cal Data	-	-
P1.7	pH Cal Reset	Yes, No	No
mV SETUP Menu			
P2.0	mV Measurement Alarm	On, Off	Off
P2.1	mV Calibration Due Alarm	On, Off	Off
P2.2	Stability Setup	On, Off	On (Low)
P2.3	mV Cal Data	-	-
P2.4	mV Cal Reset	Yes, No	No
Ion SETUP Menu			
P3.0	Ion Unit Setup	ppm, ppt, mg/l, g/l, mmol/l, mol/l	ppm
P3.1	Ion Measurement Alarm	On, Off	Off
P3.2	Ion Calibration Due Alarm	On, Off	Off
P3.3	Stability Setup	On, Off	On (Low)
P3.4	Ion Mode Setup	High, Low	High
P3.5	Ion Cal Data	-	-
P3.6	Ion Cal Reset	Yes, No	No
Meter SETUP Menu			
P4.0	Date/Time Setup	-	-
P4.1	Backlight Setup	On, Off	On
P4.2	Data Log Setup	Auto, Manual	Manual
P4.3	Memory Recall Setup	Auto, Manual	Manual
P4.4	Tx/Rx Parameter	Baud Rate: 4800, 9600, 19200, 38400	9600
		Stop Bit: One, Two	One
		Parity Bit: None, Odd, Even	Even
P4.5	Data Transfer	Current, Memory	Current
P4.6	Memory Clear Setup	Yes, No	No
P4.7	Meter Reset	Yes, No	No

15 TROUBLESHOOTING & ERROR MESSAGES

TROUBLESHOOTING

Problem	Possible Cause	Solution
Power ON but no display	AC adapter not connected properly	Connect AC adapter properly
Unstable Reading	Electrode submersion in sample is insufficient	Place electrode deeper into sample
	Broken electrode	Replace electrode
	External noise causing instability in reading.	Remove or switch off interfering motor
	Dirty electrode	Clean Electrode. Reactivate if necessary
Slow response	Dirty electrode	Clean Electrode. Reactivate if necessary

ERROR MESSAGES

LCD Display	Indicates	Cause	Solution
Error: EEPROM Read Error	Memory write error	Unit is too old (> 10 years)	Turn meter off and return to authorized distributor if necessary
Error: EEPROM write Error	Memory checksum error	Hardware failure	Turn meter off and return to authorized distributor if necessary
Error: DTR is set too high	DTR line is disconnected	Hardware fault	Turn meter off and return to authorized distributor if necessary
Error: Communication error	Frame/parity errors		Turn meter off and return to authorized distributor if necessary
Error: Buffer Overflow	Received buffer overflowing		Turn meter off and return to authorized distributor if necessary
Error: pH Offset Error	pH offset too much	pH offset should not exceed ± 1 pH from the display	Check electrode condition Make sure buffer is fresh and correct Recalibrate meter
Error: pH Slope Error	Incorrect pH slope	pH slope is out of allowable limit	Check electrode condition Make sure buffer is fresh and correct Recalibrate meter
Error: Ion Slope Error (pH 2100 meter only)	Incorrect ion slope	Average ion slope is not within 10mV-75mV/decade	Check electrode condition Make sure buffer is fresh and correct Recalibrate meter
Error: mV Offset too large	Offset too much	Value input is not within ± 150.0 mV from the display	Recalibrate meter
Error: Out of Range	Out of Range	Value input exceeds the specified range	Re-enter value
Error: ATC offset too much	Offset of temp. probe too much	Temp. calibration offset is not within $\pm 5^{\circ}\text{C}$ (or $\pm 9^{\circ}\text{F}$)	Re-enter value
Error: Too much offset@7pH	Offset too much	pH offset should not exceed ± 1 pH from the display (custom pH buffer)	Re-enter value
Error: Slope out:75%-105%	Incorrect pH slope	pH slope is not within 75% to 105% (custom pH buffer)	Re-enter value
Error: Pts too close Or slope diff. sign	Incorrect slope alignment	Slope is not negative or cal. Points are not ± 1 pH apart (custom pH buffer)	Re-enter value

16 SPECIFICATIONS

<p>pH</p> <p>Range</p> <p>Resolution</p> <p>Accuracy</p> <p>Calibration</p> <p>pH Buffer Set Options</p>	<p>-1.000 to 14.000 pH</p> <p>0.001 / 0.01 pH (user-selectable)</p> <p>± 0.002 / ±0.01 pH</p> <p>1 to 5 points (standard buffers); first point must be pH 7.000, 6.860 (offset) Min. 2 points and Max. 5 points for custom entry</p> <p>1 - USA: pH 1.68, 4.01, 7.00, 10.01, 12.45 2- NIST: pH 1.68, 4.01, 6.86, 9.18, 12.45 3- Bf1: 1.68, 4.01, 7.00, 9.18, 12.45 4-Bf2: 1.68, 4.01, 6.86, 10.01, 12.45 5 - Custom entry buffer calibration</p>
<p>mV/ Relative mV</p> <p>Range</p> <p>Resolution</p> <p>Accuracy</p> <p>Calibration</p>	<p>- 1850.0 to 1850.0 mV</p> <p>0.1 mV</p> <p>± 0.2 mV</p> <p>mV offset up to ± 150 mV</p>
<p>Temperature</p> <p>Range</p> <p>Resolution</p> <p>Accuracy</p> <p>Calibration</p>	<p>-5.0 to 105.0 °C; 23.0 to 221.0 °F</p> <p>0.1 °C / °F</p> <p>± 0.3 °C / 0.5 °F</p> <p>Manual Temperature compensation: adjust from -0.5 to 105.0°C/ 23.0 to 221.0°F Automatic Temperature compensation (ATC) offset ±5.0°C/ ±9.0°F</p>
<p>pH 2100 meter only</p>	
<p>Ion</p> <p>Range</p> <p>Resolution (High resolution mode: ±500.0 mV)</p> <p>Resolution (Low resolution mode: ±1850.0 mV)</p> <p>Accuracy</p> <p>Calibration</p> <p>Minimum Average Slope</p> <p>Maximum Average Slope</p>	<p>0.001 to 19999</p> <p>0.001: from 0.001 to 0.999 0.01: from 1.00 to 9.99 0.1: from 10.0 to 99.9 1: from 100 to 19999</p> <p>0.001: from 0.001 to 0.099 0.01: from 0.10 to 0.99 0.1: from 1.0 to 9.9 1: from 10 to 19999</p> <p>± 0.5% of full scale for monovalent ions 1% of full scale for divalent ions</p> <p>2 to 5 points, First point keyed in. the rest are selected using the ▲MI and ▼MR keys</p> <p>10 mV/ decade 75 mV/ decade</p>
<p>Inputs</p> <p>Output</p> <p>Recorder Output</p> <p>Power Requirements</p> <p>Display</p> <p>Dimensions (L x W x H)</p> <p>Weight</p>	<p>BNC, Phono (ATC), Reference, Ground</p> <p>RS232C</p> <p>± 1800 mV, 1 mV/mV unit</p> <p>AC/DC 9V Adapter (110 VAC/220 VAC)</p> <p>Custom Dual LCD (1 x 4 digit, 1 x 3.5 digit, 24 annunciators)</p> <p>230 x 180 x 63 mm (meter only); 395 x 260 x 90 mm (boxed)</p> <p>1.4lbs/ 850 gm (unit); 1400 gm (boxed)</p>

17 ACCESSORIES

Consult your Authorized Distributors for these items and other range of specialized pH electrodes or Ion Selective Electrodes.

Item Description	Eutech Instruments Order Code	Oakton Instruments Order Code
Glass-body combination pH electrode (refillable) with 1m cable length and BNC connector	EC-FG73504-01B	35801-04
Plastic-body combination double junction pH electrode with 1m cable length and BNC connector	EC-FC72522-01B	35805-05
Plastic-body combination double junction ORP electrode with 1m cable length and BNC connector	EC-FC79602-01B	35805-15
Temperature probe (for ATC)	EC-PH5-TEMB01P	35613-05
Meter to computer communication 1 m cable length (9-pin male to 25-pin female)	ECCA01M09F25	35615-09
Meter to computer communication 1 m cable length (25-pin male to 25-pin male)	ECCA01M09M25	35622-59
Serial Impact Dot-matrix Micro-printer; paper-roll portable printer with 25-pin female connector, with a roll of paper and 120VAC power adapter provided	EC-MICROPRNTR01	35622-00
Serial Impact Dot-matrix Micro-printer; paper-roll portable printer with 25-pin female connector, with a roll of paper and 220VAC power adapter provided	EC-MICROPRNTR02	35622-05
ADPTR, SMPS, 100/240VAC, 9V, 6W Centre+,with USA/ UK/ EUR Plug	60X030130	35621-07
pH 4.01 calibration buffer (480 ml) (1 pint)	EC-BU-4BT	00654-00
pH 7.01 calibration buffer (480 ml) (1 pint)	EC-BU-7BT	00654-04
pH 10.01 calibration buffer (480 ml) (1 pint)	EC-BU-10BT	00654-08
Protein Cleaning Solution for pH electrode (480 ml) (1 pint)	EC-DPC-BT	00653-06
Storage Solution for pH electrode (480 ml) (1 pint)	EC-RE-005	00653-04
pH sachet assortment pack; 5 each of pH4.01, 7.00, 10.01 and deionized water (20 x 20 ml per box)	EC-AST-PK	35653-04
pH 4.01 buffer sachets (20 x 20 ml per box)	EC-BU-4BS	35653-01
pH 7.00 buffer sachets (20 x 20 ml per box)	EC-BU-7BS	35653-02
pH 10.01 buffer sachets (20 x 20 ml per box)	EC-BU-10BS	35653-03
Deionised water rinse sachets (20 x 20 ml per box)	EC-RIN-WT	35653-00

18 WARRANTY

Eutech Instruments/ Oakton Instruments supplies this bench meter with a **3-year** warranty and **6-month** warranty for against manufacturing defects from the date of purchase. If repair or adjustment is necessary and has not been the result of abuse or misuse within the warranty period, please return, freight prepaid, and correction will be made without charge. Out of warranty items will be repaired on a charge basis.

Exclusions to the Warranty

The warranty shall not apply to defects resulting from:

- Improper or inadequate maintenance by customer;
- Unauthorized modification or misuse;
- Operation outside of the environmental specifications of the products.

Return of Items

Authorization must be obtained from your Authorized Distributor or Customer Service Dept. before returning items for any reason. When applying for authorization, please include data regarding reason the items are to be returned.

Packing the item for repair should be done using the original packaging or material, with information about any fault identified.

Shipment damage as a result of inadequate packaging is your or your distributor's responsibility, whoever applicable.

Note: Eutech Instruments/ Oakton Instruments reserves the rights to make improvements in design, construction, and appearance of products without notice.

NOTES

For more information on Eutech Instruments/ Oakton Instruments' products, contact your nearest distributor or visit our website listed below:

<p>Oakton Instruments P.O Box 5136, Vernon Hills, IL60061, USA Tel: (1) 888-462-5866 Fax: (1) 847-247-2984 E-mail: info@4oakton.com Web-sites: www.4oakton.com</p>	<p>Eutech Instruments Pte Ltd Blk 55, Ayer Rajah Crescent, #04-16/24 Singapore 139949 Tel: (65) 6778 6876 Fax: (65) 6773 0836 E-mail: eutech@thermofisher.com Web-site: www.eutechinst.com</p>	<p>Distributed by:</p>
--	--	-------------------------------