

# GE Sensing

## Key Benefits

- Multivariable vortex flowmeter for measuring volumetric flow, temperature, pressure, density, and mass flow using a single meter
- Measures most gases, liquids and steam without the need to recalibrate
- Advanced design and digital signal processing for vibration isolation
- Cost effective, accurate and reliable meter for volumetric and mass flow measurement for pipe sizes from ½ in to 8 in (15 mm to 200 mm)
- Energy management through accurate measurement of both temperature and mass flow simultaneously
- Remote monitoring and integration to DCS using HART® and Modbus® communication protocols
- Significant cost savings through reduced installation costs, wiring runs and services support using MV meter with no moving parts
- FM USA/Canada-approved, explosion-proof and dust ignition-proof

## Applications

- Ideal for high temperature and high velocity steam
- Power Generation—steam applications
- Industrial—HVAC, district energy management
- Commercial—building, campus and facility energy management
- Oil & gas—allocation of natural gas
- Petrochemical—mass balancing, reaction processes heating

---

# PanaFlow™ MV80

In-line Multivariable  
Flowmeter for Mass,  
Temperature, and  
Pressure



# GE Sensing

## Unique Multivariable Design

GE Sensing's PanaFlow MV80 In-line Multivariable Mass Vortex flowmeter is the next generation vortex meter. PanaFlow MV80's multivariable design consists of a vortex shedding velocity sensor, an RTD temperature sensor and a solid state pressure transducer that measures the mass flow rate of steam, gases and liquids.

Other meter types use external process measurements to calculate mass flow. The temperature and pressure devices are typically not installed in the same location as the flowmeter. Process conditions can vary greatly between the two locations, causing inaccurate mass flow readings. PanaFlow MV80 measures velocity, temperature and pressure at the same location, which provides more accurate process measurement.

## Simple and Cost Effective

Integrating pressure and temperature into the vortex flowmeter simplifies system complexity and helps minimize initial capital costs, as well as reduce the installation costs. There is no need to purchase additional instrumentation to monitor pressure and temperature since the PanaFlow MV80 will output all parameters to your data acquisition system.

The product line is available with a wide range of options and meter configurations to meet your specific application requirements.

## Portfolio of Flowmeter Solutions

GE Sensing is committed to providing customers with the best technologies for their flow measurement needs. PanaFlow MV80 is the newest addition to the PanaFlow family of flowmeters, providing effective solutions for smaller pipe sizes for a variety of applications. GE Sensing offers the PanaFlow MV80 in a number of configurations to best suit your application measurement needs.

## PanaFlow MV80-VTP

The MV80-VTP offers flow computer functionality in a compact field device. This multivariable instrument incorporates temperature and pressure sensors to provide an instantaneous reading of compensated mass flow rate of gases, liquids and steam. In addition to outputs for totalized mass and alarm settings, the field-configurable electronics deliver up to three analog 4-20 mA outputs of five process measurements, including volumetric flow rate, mass flow rate, pressure, temperature and density.

## PanaFlow MV80-VT

The MV80-VT integrates a precision 1000 ohm platinum RTD temperature sensor used to calculate and output a compensated mass flow reading. This device is typically used to measure flow rates of saturated steam.

## PanaFlow MV80-V

The MV80-V delivers a direct reading of volumetric flow rate—generally the most cost-effective solution for liquid flow monitoring—in applications ranging from general water flows to hydrocarbon fuel flow measurement.

## PanaFlow MV80-EM

The MV80-EM energy monitoring option enables real time-of-flight diffraction calculation of energy consumption for a facility or process. The meter can be programmed to measure steam, hot water or chilled water. This option uses the MV80-EM flowmeter to monitor one side of the process, either sent or return, and uses the input from a second separate temperature sensor on the opposite leg of the process to calculate the change in energy. Selectable energy units include BTU, joules, calories, Watt-hours, Megawatt-hours and Horsepower-hours. The local or remote electronics indicate two temperatures, delta T, mass total and energy total.

# PanaFlow MV80 Specifications

## Performance

### Accuracy

Mass flow rate accuracy for gas and steam based on 50-100% of pressure range

| PanaFlow MV80 Accuracy Flowmeter |                     |                     |
|----------------------------------|---------------------|---------------------|
| Process Variables                | Liquids             | Gas and Steam       |
| Volumetric Flow Rate             | ± .7% of Rate       | ± 1% of Rate        |
| Mass Flow Rate                   | ± 1% of Rate        | ± 1.5% of Rate      |
| Temperature                      | ± 2°F (± 1°C)       | ± 2°F (± 1°C)       |
| Pressure                         | ± .3% of Full Scale | ± .3% of Full Scale |
| Density                          | ± .3% of Reading    | ± .5% of Reading    |

### Repeatability

|                      |                       |
|----------------------|-----------------------|
| Mass Flow Rate       | ± 0.2% of rate        |
| Volumetric Flow Rate | ± 0.1% of rate        |
| Temperature          | ± 0.2°F (± 0.1°C)     |
| Pressure             | ± 0.05% of full scale |
| Density              | ± 0.1% of reading     |

### Stability Over 12 Months

|                      |                      |
|----------------------|----------------------|
| Mass Flow Rate       | ± 0.2% of rate       |
| Volumetric Flow Rate | negligible           |
| Temperature          | ± 0.9°F (± 0.5°C)    |
| Pressure             | ± 0.1% of full scale |
| Density              | ± 0.1% of reading    |

### Response Time

Adjustable from 1 to 100 seconds

## Operating

### Process and Ambient Temperature

|   |                                |
|---|--------------------------------|
| Process Standard Temperature (code ST): | -40 to 500°F<br>(-40 to 260°C) |
| Process High Temperature (code HT):     | Up to 750°F<br>(400°C)         |
| Ambient Operating:                      | -5 to 185°F<br>(-20 to 85°C)   |
| Ambient Storage:                        | -40 to 185°F<br>(-40 to 85°C)  |

| Pressure Transducer Ratings   |      |                          |      |
|-------------------------------|------|--------------------------|------|
| Full Scale Operating Pressure |      | Max. Over-Range Pressure |      |
| psia                          | bara | psia                     | bara |
| 30                            | 2    | 60                       | 4    |
| 100                           | 7    | 200                      | 14   |
| 300                           | 20   | 600                      | 40   |
| 500                           | 35   | 1000                     | 70   |
| 1500                          | 100  | 2500                     | 175  |

### Power Requirements

Model MV80-V: 12-36 VDC loop powered  
 Model MV80-VTP, DC option: 12-36 VDC, 100 mA max  
 Model MV80-VTP, AC option: 85-240 VAC, 50/60 Hz, 1 Watt

### Display

Alphanumeric 2 line x 16 character LCD digital display

Six pushbuttons for full field configuration

Pushbuttons can be operated with magnetic wand without removal of enclosure covers

Display can be mounted in 90° intervals for better viewing

### Output Signals

Analog: 4-20 mA, loop powered for volumetric meters

Alarm: Solid state relay, 40 VDC

Totalizer Pulse: 50 millisecond, 40 VDC

Volumetric: One analog, one totalizer pulse, HART

Multivariable: Up to three analog signals, three alarms, one totalizer pulse, HART

Multivariable option: Modbus process monitoring

## Physical

### Wetted Materials

316L stainless steel, plus:

- PTFE-based thread sealant on models with pressure transducer
- PTFE packing on standard temperature models with packing gland
- Graphite-based packing on high temperature models with packing gland

### FM USA/Canada Approvals

Explosion-proof for Class I, Division 1, Groups B, C & D  
 Dust-ignitionproof for Class II/III, Division 1, Groups E, F & G

Type 4x and IP66

T6 at Tamb = 140°F (60°C)

# PanaFlow MV80 Specifications

## Sizing Considerations

| Condition                                 | Piping Conditions |            |
|---|-------------------|------------|
|   | Pipe Diameters, D |            |
|   | Upstream          | Downstream |
| One 90° elbow before meter                | 10D               | 5D         |
| Two 90° elbows before meter               | 15D               | 5D         |
| Two 90° elbows before meter, out of plane | 25D               | 5D         |
| Reduction before meter                    | 10D               | 5D         |
| Expansion before meter                    | 20D               | 5D         |
| Partially open valve                      | 25D               | 5D         |

### Velocity Range

Maximum velocity, liquid: 30 feet/sec (9 meters/second)

Minimum velocity, liquid: 1 foot/sec (.3 meters/second)

Maximum velocity, gas or steam: 300 feet/sec (90 meters/second)

Minimum velocity, gas or steam feet/sec (meters/second):

$$\frac{5}{\sqrt{\text{density (lb/ft}^3\text{)}}} \qquad \frac{6.1}{\sqrt{\text{density (kg/m}^3\text{)}}}$$

Consult the PanaFlow MV Sizing Program for easy calculation of flow range.

| Water Minimum and Maximum Flow Rates |                        |      |     |     |     |     |      |      |      |
|--------------------------------------|------------------------|------|-----|-----|-----|-----|------|------|------|
| Rate                                 | Nominal Pipe Size (in) |      |     |     |     |     |      |      |      |
|                                      | 0.5                    | 0.75 | 1   | 1.5 | 2   | 3   | 4    | 6    | 8    |
| GPM min                              | 0.9                    | 1.4  | 2.2 | 5.5 | 9.2 | 21  | 36   | 81   | 142  |
| GPM max                              | 22                     | 40   | 67  | 166 | 276 | 618 | 1076 | 2437 | 4270 |
|                                      | Nominal Pipe Size (mm) |      |     |     |     |     |      |      |      |
|                                      | 15                     | 20   | 25  | 40  | 50  | 80  | 100  | 150  | 200  |
| M <sup>3</sup> /hr min               | 0.2                    | 0.3  | 0.5 | 1.3 | 2.1 | 4.7 | 8.1  | 18   | 32   |
| M <sup>3</sup> /hr max               | 5                      | 9    | 15  | 38  | 63  | 140 | 244  | 554  | 970  |

## Dimensional Outline: Remote Electronics Option

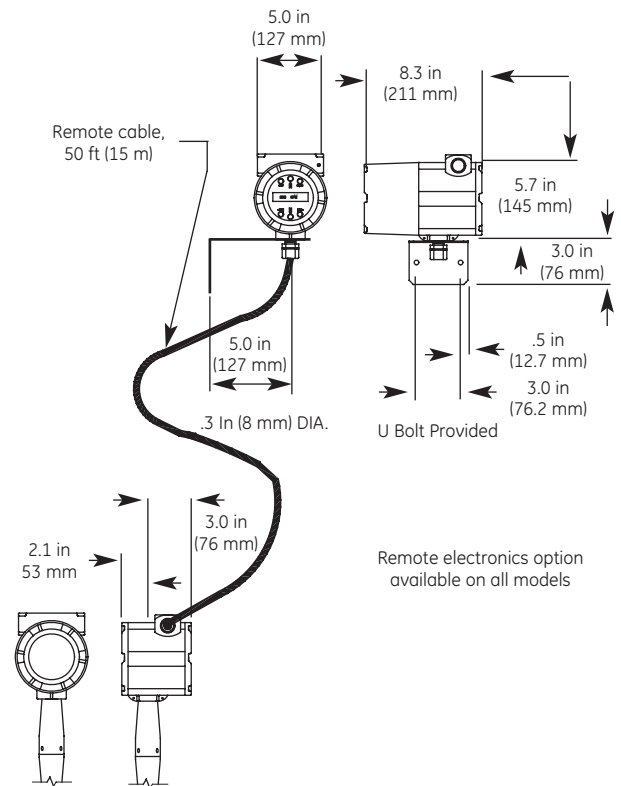

# PanaFlow MV80 Specifications

## Dimensional Outline: In-line Flanged Models

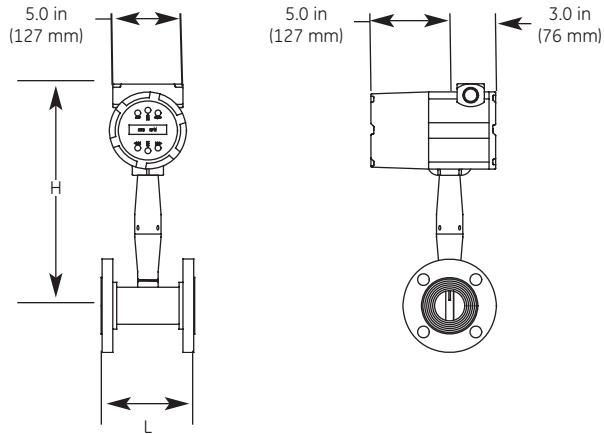

## Dimensional Outline: Wafer Models

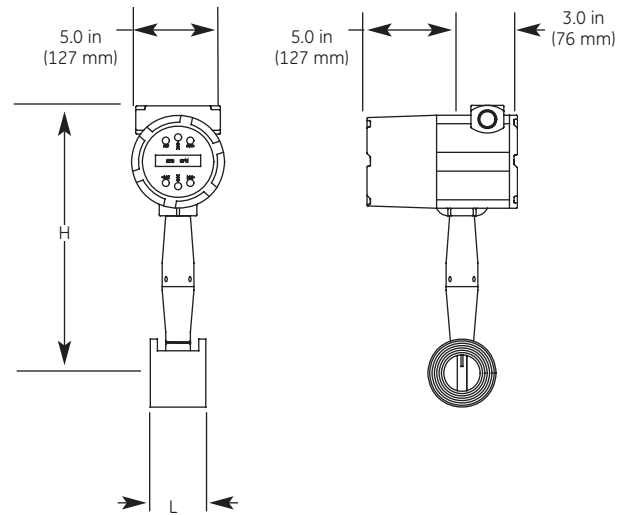

| Flow Meter Nominal Size | L                   | H                   | WEIGHT               |                      |                      |
|-------------------------|---------------------|---------------------|----------------------|----------------------|----------------------|
|                         |                     |                     | ANSI 150<br>(PN 16)  | ANSI 300<br>(PN 40)  | ANSI 600<br>(PN 64)  |
| 1/2 in (15 mm)          | 4.6 in<br>(116 mm)  | 14.8 in<br>(376 mm) | 12 lb<br>(5.5kg)     | 12.5 lb<br>(5.7 kg)  | 13 lb<br>(5.9 kg)    |
| 3/4 in (20 mm)          | 4.8 in<br>(122 mm)  | 15 in<br>(381 mm)   | 13 lb<br>(5.9 kg)    | 14 lb<br>(6.4 kg)    | 14.5 lb<br>(6.6 kg)  |
| 1 (25 mm)               | 5 in<br>(126 mm)    | 15 in<br>(381 mm)   | 13.4 lb<br>(6.1 kg)  | 16.3 lb<br>(7.4 kg)  | 16.3 lb<br>(7.4 kg)  |
| 1-1/2 in (40 mm)        | 5.5 in<br>(140 mm)  | 15 in<br>(384 mm)   | 14.5 lb<br>(6.6 kg)  | 22.7 lb<br>(10.3 kg) | 24.6 lb<br>(11.2 kg) |
| 2 in (50 mm)            | 6.0 in<br>(153 mm)  | 15.3 in<br>(389 mm) | 19.4 lb<br>(8.8 kg)  | 26.8 lb<br>(12.2 kg) | 33.2 lb<br>(15.1 kg) |
| 3 in (80 mm)            | 7.0 in<br>(175 mm)  | 15.8 in<br>(401 mm) | 27.5 lb<br>(12.5 kg) | 39.4 lb<br>(17.9 kg) | 56.1 lb<br>(25.5 kg) |
| 4 in (100 mm)           | 8.0 in<br>(203 mm)  | 16.2 in<br>(411 mm) | 43.3 lb<br>(19.7 kg) | 60.3 lb<br>(27.4 kg) | 96 lb<br>(43.6 kg)   |
| 6 in (150 mm)           | 9 in<br>(229 mm)    | 17.3 in<br>(439 mm) | 48.4 lb<br>(22.0 kg) | 96 lb<br>(43.6 kg)   | 178 lb<br>(80.8 kg)  |
| 8 in (200 mm)           | 10.5 in<br>(267 mm) | 18.2 in<br>(462 mm) | 71 lb<br>(32.2 kg)   | 148 lb<br>(67.4 kg)  | 299 lb<br>(136 kg)   |

Add 11 lb (5 kg) for remote electronics

| Flow Meter Nominal Size | L                  | H                   | WEIGHT               |
|-------------------------|--------------------|---------------------|----------------------|
|                         |                    |                     |                      |
| 1 in (25 mm)            | 2.8 in<br>(71 mm)  | 14.8 in<br>(376 mm) | 10.1 lb<br>(4.6 kg)  |
| 1-1/2 in (40 mm)        | 2.8 in<br>(71 mm)  | 15.1 in<br>(384 mm) | 11.9 lb<br>(5.4 kg)  |
| 2 in (50 mm)            | 3.0 in<br>(76 mm)  | 15.3 in<br>(389 mm) | 14.1 lb<br>(6.4 kg)  |
| 3 in (80 mm)            | 4 in<br>(102 mm)   | 15.8 in<br>(401 mm) | 22.7 lb<br>(10.3 kg) |
| 4 in (100 mm)           | 4.7 in<br>(119 mm) | 16.2 in<br>(411 mm) | 33 lb<br>(15 kg)     |

Add 11 lb (5 kg) for remote electronics

# PanaFlow MV80 Specifications

**Typical Saturated Steam Minimum and Maximum  
Flow Rates (lb/hr)**

| Pressure | Nominal Pipe Size (in) |      |      |       |       |       |       |        |        |
|----------|------------------------|------|------|-------|-------|-------|-------|--------|--------|
|          | 0.5                    | 0.75 | 1    | 1.5   | 2     | 3     | 4     | 6      | 8      |
| 5 psig   | 6.5                    | 12   | 20   | 49    | 82    | 183   | 318   | 722    | 1264   |
|          | 52                     | 122  | 265  | 650   | 1087  | 2431  | 4231  | 9594   | 16806  |
| 100 psig | 15                     | 27   | 46   | 112   | 187   | 419   | 728   | 1652   | 2893   |
|          | 271                    | 639  | 1386 | 3405  | 5690  | 12729 | 22156 | 50233  | 87998  |
| 200 psig | 20                     | 37   | 62   | 151   | 253   | 565   | 983   | 2229   | 3905   |
|          | 493                    | 1163 | 2525 | 6203  | 10365 | 23184 | 40354 | 91494  | 160279 |
| 300 psig | 24                     | 45   | 74   | 182   | 304   | 680   | 1184  | 2685   | 4704   |
|          | 716                    | 1688 | 3664 | 9000  | 15040 | 33642 | 58556 | 132763 | 232575 |
| 400 psig | 28                     | 51   | 85   | 209   | 349   | 780   | 1358  | 3079   | 5393   |
|          | 941                    | 2220 | 4816 | 11831 | 19770 | 44222 | 76971 | 174516 | 305717 |
| 500 psig | 31                     | 57   | 95   | 233   | 389   | 870   | 1514  | 3433   | 6014   |
|          | 1170                   | 2760 | 5988 | 14711 | 24582 | 54987 | 95710 | 217001 | 380148 |

**Typical Saturated Steam Minimum and Maximum  
Flow Rates (kg/hr)**

| Pressure | Nominal Pipe Size (mm) |      |      |      |      |       |       |       |        |
|----------|------------------------|------|------|------|------|-------|-------|-------|--------|
|          | 15                     | 20   | 25   | 40   | 50   | 80    | 100   | 150   | 200    |
| 0 barg   | 3                      | 5    | 8    | 19   | 32   | 72    | 126   | 286   | 500    |
|          | 18                     | 42   | 91   | 224  | 375  | 838   | 1459  | 3309  | 5797   |
| 5 barg   | 6                      | 11   | 18   | 45   | 75   | 167   | 290   | 658   | 1153   |
|          | 95                     | 224  | 485  | 1192 | 1992 | 4455  | 7754  | 17581 | 30799  |
| 10 barg  | 8                      | 15   | 24   | 59   | 99   | 222   | 387   | 877   | 1537   |
|          | 168                    | 397  | 862  | 2118 | 3539 | 7915  | 13777 | 31237 | 54720  |
| 15 barg  | 9                      | 17   | 29   | 71   | 119  | 266   | 463   | 1050  | 1840   |
|          | 241                    | 569  | 1236 | 3036 | 5073 | 11347 | 19750 | 44779 | 78444  |
| 20 barg  | 11                     | 20   | 33   | 81   | 136  | 304   | 529   | 1199  | 2100   |
|          | 314                    | 742  | 1610 | 3956 | 6611 | 14787 | 25738 | 58355 | 102226 |
| 30 barg  | 13                     | 24   | 40   | 99   | 165  | 369   | 642   | 1455  | 2548   |
|          | 463                    | 1092 | 2370 | 5822 | 9729 | 21763 | 37880 | 85884 | 150451 |

**Typical Air Minimum and Maximum Flow Rates (SCFM)  
Air at 70°F**

| Pressure | Nominal Pipe Size (in) |      |      |      |       |       |       |        |        |
|----------|------------------------|------|------|------|-------|-------|-------|--------|--------|
|          | 0.5                    | 0.75 | 1    | 1.5  | 2     | 3     | 4     | 6      | 8      |
| 0 psig   | 1.8                    | 3    | 5    | 13   | 22    | 50    | 87    | 198    | 347    |
|          | 18                     | 41   | 90   | 221  | 369   | 826   | 1437  | 3258   | 5708   |
| 100 psig | 5                      | 9    | 15   | 38   | 63    | 141   | 245   | 555    | 972    |
|          | 138                    | 325  | 704  | 1730 | 2890  | 6466  | 11254 | 25515  | 44698  |
| 200 psig | 7                      | 13   | 21   | 52   | 86    | 193   | 335   | 761    | 1332   |
|          | 258                    | 609  | 1322 | 3248 | 5427  | 12140 | 21131 | 47911  | 83931  |
| 300 psig | 8                      | 15   | 25   | 63   | 104   | 234   | 407   | 922    | 1615   |
|          | 380                    | 896  | 1944 | 4775 | 7978  | 17847 | 31064 | 70431  | 123375 |
| 400 psig | 10                     | 18   | 29   | 72   | 120   | 269   | 467   | 1060   | 1857   |
|          | 502                    | 1183 | 2568 | 6309 | 10542 | 23580 | 41043 | 93057  | 163000 |
| 500 psig | 11                     | 20   | 33   | 80   | 134   | 300   | 521   | 1182   | 2071   |
|          | 624                    | 1472 | 3195 | 7849 | 13115 | 28034 | 51063 | 115775 | 203000 |

**Typical Air Minimum and Maximum Flow Rates (nm<sup>3</sup>/hr)  
Air at 20°C**

| Pressure | Nominal Pipe Size (mm) |      |      |       |       |       |       |        |        |
|----------|------------------------|------|------|-------|-------|-------|-------|--------|--------|
|          | 15                     | 20   | 25   | 40    | 50    | 80    | 100   | 150    | 200    |
| 0 barg   | 3                      | 5    | 9    | 21    | 36    | 79    | 138   | 313    | 549    |
|          | 28                     | 66   | 142  | 350   | 584   | 1307  | 2275  | 5157   | 9034   |
| 5 barg   | 7                      | 13   | 21   | 52    | 87    | 194   | 337   | 764    | 1339   |
|          | 165                    | 390  | 847  | 2080  | 3476  | 7775  | 13533 | 30682  | 53749  |
| 10 barg  | 9                      | 17   | 29   | 70    | 117   | 262   | 457   | 1035   | 1814   |
|          | 304                    | 716  | 1554 | 3819  | 6381  | 14273 | 24844 | 56329  | 98676  |
| 15 barg  | 11                     | 21   | 34   | 85    | 142   | 317   | 551   | 1250   | 2190   |
|          | 442                    | 1044 | 2265 | 5565  | 9299  | 20801 | 36205 | 82087  | 143801 |
| 20 barg  | 13                     | 24   | 40   | 97    | 162   | 363   | 632   | 1434   | 2511   |
|          | 582                    | 1373 | 2979 | 7318  | 12229 | 27354 | 47612 | 107949 | 189105 |
| 30 barg  | 16                     | 29   | 48   | 118   | 198   | 442   | 770   | 1745   | 3057   |
|          | 862                    | 2034 | 4414 | 10843 | 18119 | 40529 | 70544 | 159942 | 280187 |

## Turndown

Turndown is application-dependent. Consult the PanaFlow MV Sizing Program for exact values. Turndown can exceed 100:1.

## PanaFlow MV80 Ordering Information

**Parent Number Code**

**MV80** In-line Multivariable Mass  
Vortex Flowmeter

**Feature 1: Multivariable Options**

- V** Volumetric flowmeter for liquid, gas and steam
- VT** Velocity and temperature sensors
- VTP** Velocity, temperature and pressure sensors
- VT-EM** Energy output options
- VTP-EM** Energy options with pressure sensor

**Feature 2: Flow Body**

- 04** 1/2-inch Nominal Bore (15 mm)
- 06** 3/4-inch Nominal Bore (20 mm)
- 08** 1-inch Nominal Bore (25 mm)
- 12** 1.5-inch Nominal Bore (40 mm)
- 16** 2-inch Nominal Bore (50 mm)
- 24** 3-inch Nominal Bore (80 mm)
- 32** 4-inch Nominal Bore (100 mm)
- 48** 6-inch Nominal Bore (150 mm)
- 64** 8-inch Nominal Bore (200 mm)

**Feature 3: Meter Body Material**

- C** Carbon Steel
- S** 316 Stainless Steel
- H** Hastelloy

**Feature 4: Process Connection**

- 150** ANSI 150# Flange
- 300** ANSI 300# Flange
- 600** ANSI 600# Flange
- W** Wafer ANSI 600#
- 16** PN 16
- 40** PN 40
- 64** PN 64

**Feature 5: Electronics Enclosure**

- L** Type 4X Enclosure
- R (25)** Remote electronics Type 4X, 25 ft (8 m) cable
- R (50)** Remote electronics Type 4X, 50 ft (8 m) cable

**Feature 6: Display Options**

- DD** Digital Display and Programming Buttons
- ND** No Display

**Feature 7: Input Power**

- DC2** 12 to 36 VDC required on 2-wire (loop powered) meters with 1AHL only
- DC4** 12 to 36 VDC standard volumetric meter on 4-wire
- AC** 100-240 VAC, 50/60 Hz

**Feature 8: Output**

- 1AHL** Loop powered option—one analog output (4-20 mA), one pulse, HART communication protocol. Must use DC2 input power
- 1AM** One analog output (4-20 mA), one alarm, one pulse, MODBUS Communication Protocol
- 3AH** Three analog outputs (4-20 mA), three alarms, one pulse, HART (VT,VTP only)
- 3AM** Three analog outputs (4-20 mA), three alarms, one pulse, MODBUS (VT,VTP only)

**Feature 9: Process Temperature Options**

- ST** Standard process temperature -40° to 500°F (-40° to 260°C)
- HT** High process temperature 750°F (400°C)

**Feature 10: Process Pressure**

- P0** No Pressure Sensor
- P1** Maximum 30 psia (2 bara), Proof 60 psia (4 bara)
- P2** Maximum 100 psia (7 bara), Proof 200 psia (14 bara)
- P3** Maximum 300 psia (20 bara), Proof 600 psia (41 bara)
- P4** Maximum 500 psia (34 bara), Proof 1000 psia (64 bara)
- P5** Maximum 1500 psia (100 bara), Proof 2500 psia (175 bara)



GE  
Sensing



©2007 GE. All rights reserved.  
920-404B

All specifications are subject to change for product improvement without notice.  
GE® is a registered trademark of General Electric Co. Other company or product names mentioned in this document may be trademarks or registered trademarks of their respective companies, which are not affiliated with GE.

[www.gesensing.com](http://www.gesensing.com)