



OPTIFLUX 4000 Handbook

Electromagnetic flow sensor

The documentation is only complete when used in combination with the relevant documentation for the converter.

All rights reserved. It is prohibited to reproduce this documentation, or any part thereof, without the prior written authorisation of KROHNE Messtechnik GmbH.

Subject to change without notice.

Copyright 2010 by
KROHNE Messtechnik GmbH - Ludwig-Krohne-Str. 5 - 47058 Duisburg (Germany)

1	Safety instructions	5
1.1	Intended use	5
1.2	Safety instructions from the manufacturer	5
1.2.1	Copyright and data protection	5
1.2.2	Disclaimer	5
1.2.3	Product liability and warranty	6
1.2.4	Information concerning the documentation	6
1.2.5	Warnings and symbols used	7
1.3	Safety instructions for the operator	7
2	Device description	8
2.1	Scope of delivery	8
2.2	Nameplates	8
3	Installation	9
3.1	Notes on installation	9
3.2	Storage	9
3.3	Transport	9
3.4	Installation conditions	10
3.4.1	Inlet and outlet	10
3.4.2	Mounting position	10
3.4.3	Flange deviation	11
3.4.4	T-section	11
3.4.5	Vibration	11
3.4.6	Magnetic field	12
3.4.7	Bends	12
3.4.8	Open discharge	13
3.4.9	Control valve	13
3.4.10	Air venting	13
3.4.11	Pump	14
3.4.12	Temperatures	14
3.5	Mounting	15
3.5.1	Torques and pressures	15
4	Electrical connections	18
4.1	Safety instructions	18
4.2	Grounding	18
4.3	Virtual reference for IFC 300 (C, W and F version)	19

5 Service20

5.1 Spare parts availability	20
5.2 Availability of services	20
5.3 Returning the device to the manufacturer.....	20
5.3.1 General information.....	20
5.3.2 Form (for copying) to accompany a returned device.....	21
5.4 Disposal	21

6 Technical data 22

6.1 Measuring principle.....	22
6.2 Technical data.....	23
6.3 Vacuum load	29
6.4 Dimensions and weights	30

7 Notes 34

1.1 Intended use

The measurement of volumetric flowrate of electrically conductive fluids. Basic measurement is the flow velocity upon which all other measurements are based.

1.2 Safety instructions from the manufacturer

1.2.1 Copyright and data protection

The contents of this document have been created with great care. Nevertheless, we provide no guarantee that the contents are correct, complete or up-to-date.

The contents and works in this document are subject to German copyright. Contributions from third parties are identified as such. Reproduction, processing, dissemination and any type of use beyond what is permitted under copyright requires written authorisation from the respective author and/or the manufacturer.

The manufacturer tries always to observe the copyrights of others, and to draw on works created in-house or works in the public domain.

The collection of personal data (such as names, street addresses or e-mail addresses) in the manufacturer's documents is always on a voluntary basis whenever possible. Whenever feasible, it is always possible to make use of the offerings and services without providing any personal data.

We draw your attention to the fact that data transmission over the Internet (e.g. when communicating by e-mail) may involve gaps in security. It is not possible to protect such data completely against access by third parties.

We hereby expressly prohibit the use of the contact data published as part of our duty to publish an imprint for the purpose of sending us any advertising or informational materials that we have not expressly requested.

1.2.2 Disclaimer

The manufacturer will not be liable for any damage of any kind by using its product, including, but not limited to direct, indirect, incidental, punitive and consequential damages.

This disclaimer does not apply in case the manufacturer has acted on purpose or with gross negligence. In the event any applicable law does not allow such limitations on implied warranties or the exclusion of limitation of certain damages, you may, if such law applies to you, not be subject to some or all of the above disclaimer, exclusions or limitations.

Any product purchased from the manufacturer is warranted in accordance with the relevant product documentation and our Terms and Conditions of Sale.

The manufacturer reserves the right to alter the content of its documents, including this disclaimer in any way, at any time, for any reason, without prior notification, and will not be liable in any way for possible consequences of such changes.

1.2.3 Product liability and warranty

The operator shall bear responsibility for the suitability of the device for the specific purpose. The manufacturer accepts no liability for the consequences of misuse by the operator. Improper installation and operation of the devices (systems) will cause the warranty to be void. The respective "Standard Terms and Conditions" which form the basis for the sales contract shall also apply.

1.2.4 Information concerning the documentation

To prevent any injury to the user or damage to the device it is essential that you read the information in this document and observe applicable national standards, safety requirements and accident prevention regulations.

If this document is not in your native language and if you have any problems understanding the text, we advise you to contact your local office for assistance. The manufacturer can not accept responsibility for any damage or injury caused by misunderstanding of the information in this document.

This document is provided to help you establish operating conditions, which will permit safe and efficient use of this device. Special considerations and precautions are also described in the document, which appear in the form of underneath icons.

1.2.5 Warnings and symbols used

Safety warnings are indicated by the following symbols.



DANGER!

This information refers to the immediate danger when working with electricity.



DANGER!

This warning refers to the immediate danger of burns caused by heat or hot surfaces.



DANGER!

This warning refers to the immediate danger when using this device in a hazardous atmosphere.



DANGER!

These warnings must be observed without fail. Even partial disregard of this warning can lead to serious health problems and even death. There is also the risk of seriously damaging the device or parts of the operator's plant.



WARNING!

Disregarding this safety warning, even if only in part, poses the risk of serious health problems. There is also the risk of damaging the device or parts of the operator's plant.



CAUTION!

Disregarding these instructions can result in damage to the device or to parts of the operator's plant.



INFORMATION!

These instructions contain important information for the handling of the device.



LEGAL NOTICE!

This note contains information on statutory directives and standards.



• **HANDLING**

This symbol designates all instructions for actions to be carried out by the operator in the specified sequence.

➔ **RESULT**

This symbol refers to all important consequences of the previous actions.

1.3 Safety instructions for the operator



WARNING!

*In general, devices from the manufacturer may only be installed, commissioned, operated and maintained by properly trained and authorized personnel.
This document is provided to help you establish operating conditions, which will permit safe and efficient use of this device.*

2.1 Scope of delivery

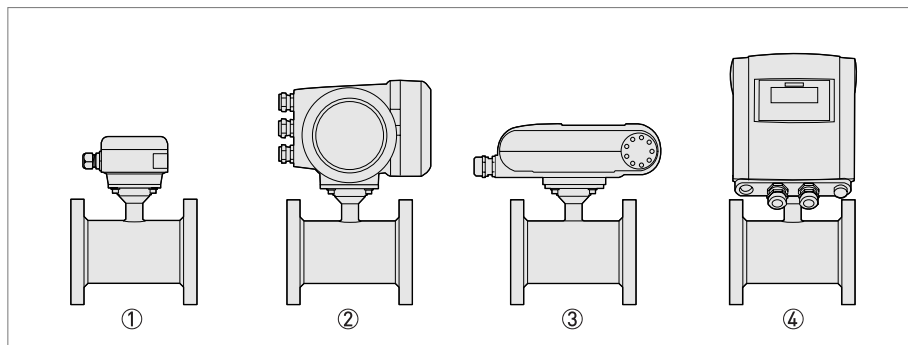

- ① Remote version
- ② Compact version with IFC 300 signal converter
- ③ Compact version with IFC 100 (0°) signal converter
- ④ Compact version with IFC 100 (45°) signal converter

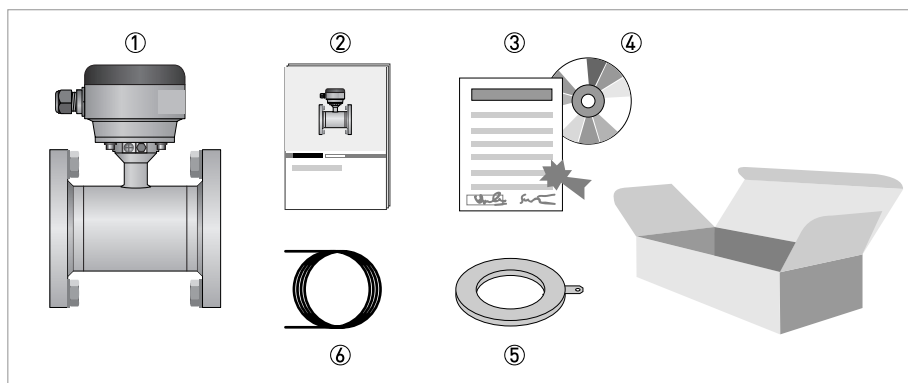

Figure 2-1: Scope of delivery

- ① Ordered flowmeter
- ② Product documentation
- ③ Factory calibration report
- ④ CD-ROM with product documentation
- ⑤ Grounding rings (optionally)
- ⑥ Cable (remote versions only)

2.2 Nameplates



INFORMATION!

Look at the device nameplate to ensure that the device is delivered according to your order. Check for the correct supply voltage printed on the nameplate.

3.1 Notes on installation

**INFORMATION!**

Inspect the cartons carefully for damage or signs of rough handling. Report damage to the carrier and to the local office of the manufacturer.

**INFORMATION!**

Check the packing list to check if you received completely all that you ordered.

**INFORMATION!**

Look at the device nameplate to ensure that the device is delivered according to your order. Check for the correct supply voltage printed on the nameplate.

3.2 Storage

- Store the device in a dry and dust-free location.
- Avoid lasting direct exposure to the sun.
- Store the device in its original packing.

3.3 Transport

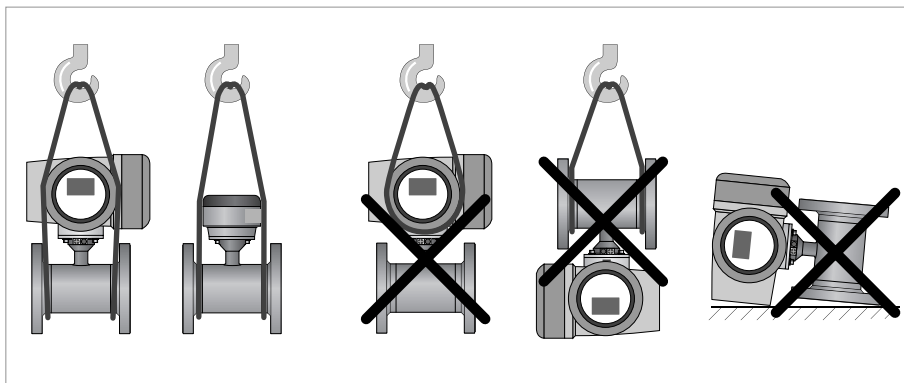

Figure 3-1: Transport

3.4 Installation conditions

3.4.1 Inlet and outlet

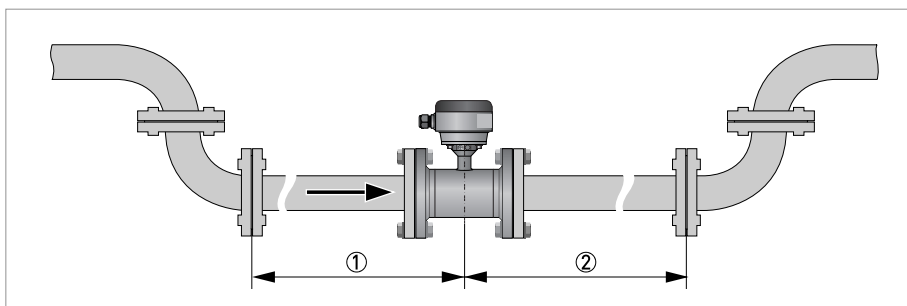

Figure 3-2: Recommended inlet and outlet sections

- ① ≥ 5 DN
- ② ≥ 2 DN

3.4.2 Mounting position

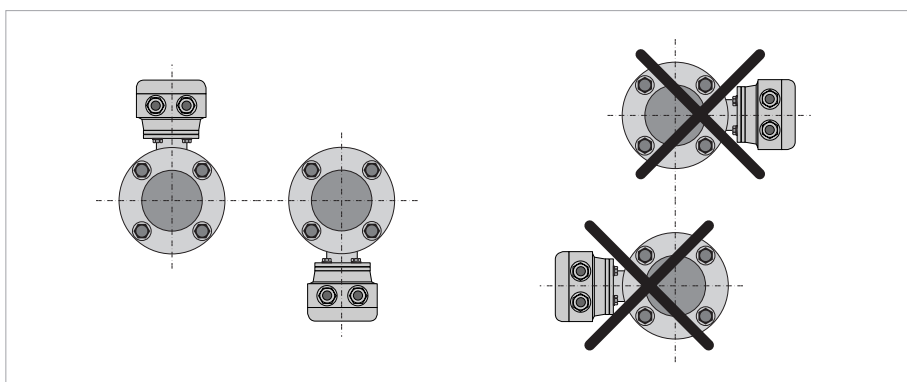

Figure 3-3: Mounting position

3.4.3 Flange deviation



CAUTION!

Max. permissible deviation of pipe flange faces:

$$L_{max} - L_{min} \leq 0.5 \text{ mm} / 0.02''$$

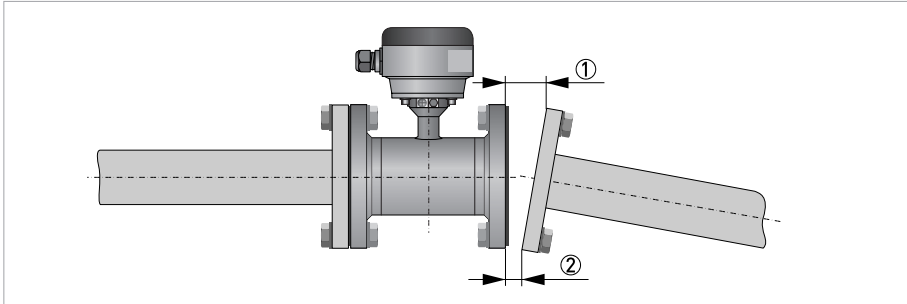

Figure 3-4: Flange deviation

- ① L_{max}
- ② L_{min}

3.4.4 T-section

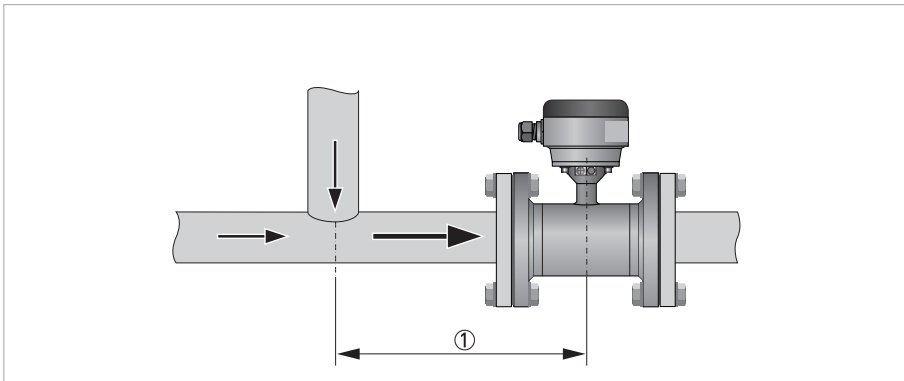

Figure 3-5: Distance after T-sections

- ① $\geq 10 \text{ DN}$

3.4.5 Vibration

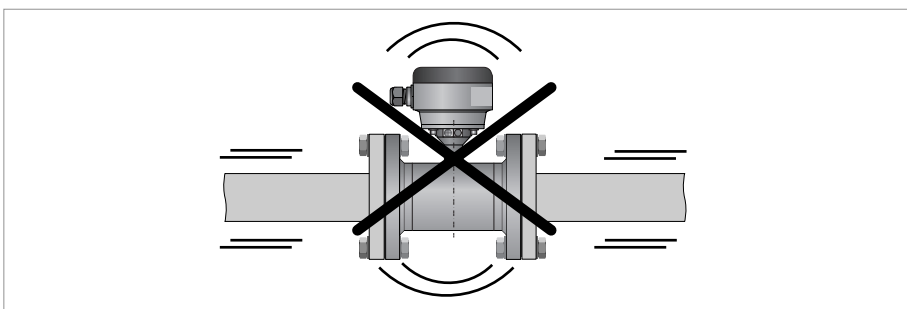

Figure 3-6: Avoid vibrations

3.4.6 Magnetic field

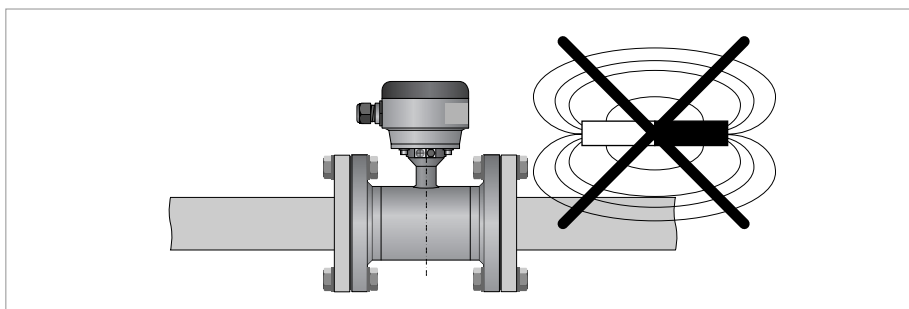

Figure 3-7: Avoid magnetic fields

3.4.7 Bends

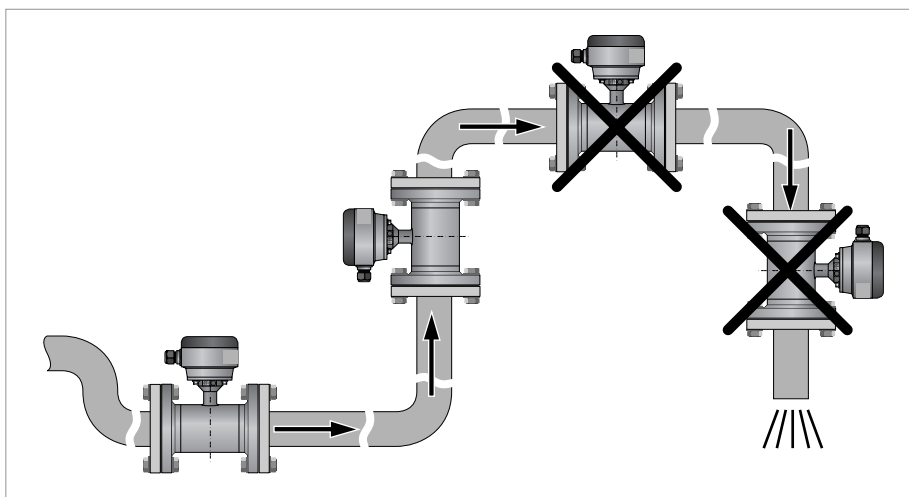

Figure 3-8: Installation in bending pipes

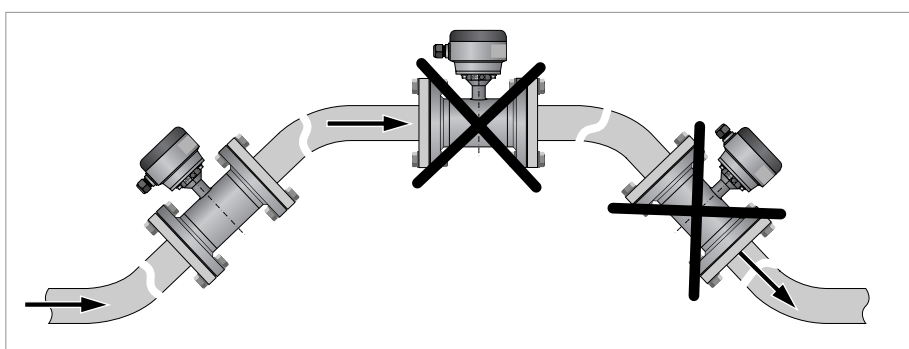

Figure 3-9: Installation in bending pipes

3.4.8 Open discharge

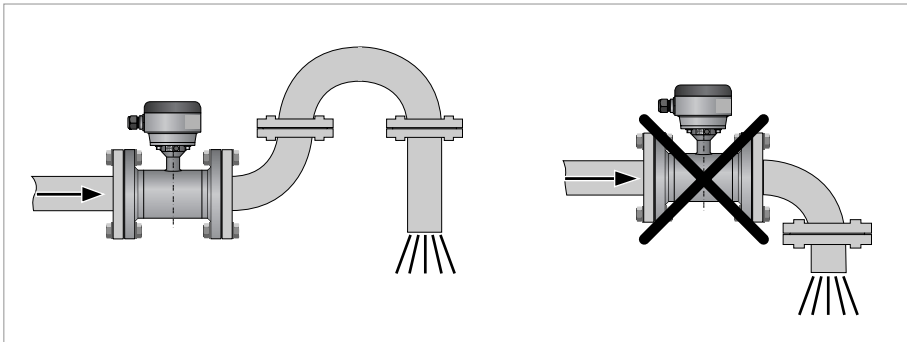

Figure 3-10: Installation before an open discharge

3.4.9 Control valve

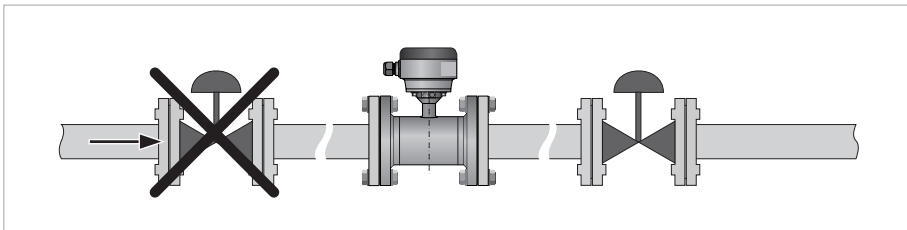

Figure 3-11: Installation before control valve

3.4.10 Air venting

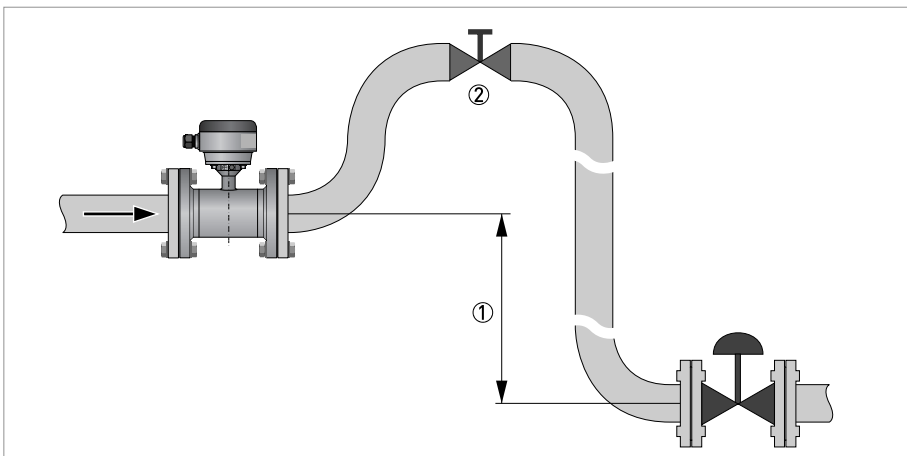

Figure 3-12: Air venting

- ① ≥ 5 m
- ② Air ventilation point

3.4.11 Pump

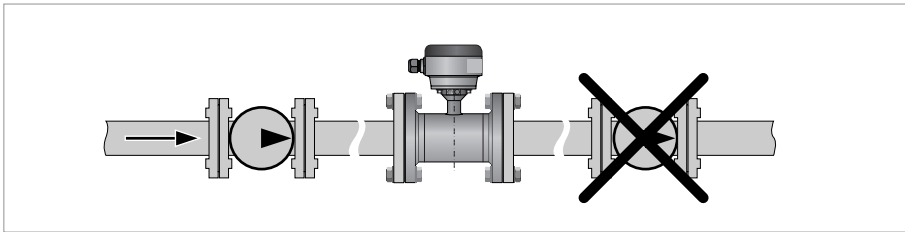

Figure 3-13: Installation after pump

3.4.12 Temperatures



CAUTION!
Protect the device from direct sunlight.

Temperature range	Process [°C]		Ambient [°C]		Process [°F]		Ambient [°F]	
	min.	max.	min.	max.	min.	max.	min.	max.

PTFE

Separate flow sensor	-40	180	-40	65	-40	356	-40	149
Compact with IFC 300	-40	140	-40	65	-40	284	-40	149
Compact with IFC 100	-40	120 ①	-40	65	-40	248 ①	-40	149

PFA

Separate flow sensor	-40	180	-40	65	-40	356	-40	149
Compact with IFC 300	-40	140	-40	65	-40	284	-40	149
Compact with IFC 100	-40	120 ①	-40	65	-40	248 ①	-40	149

ETFE

Separate flow sensor	-40	120	-40	65	-40	248	-40	149
Compact with IFC 300	-40	120	-40	65	-40	248	-40	149
Compact with IFC 100	-40	120	-40	65	-40	248	-40	149

Hardrubber

Separate flow sensor ②	-5	80	-40	65	23	176	-40	149
Compact with IFC 300 ②	-5	80	-40	65	23	176	-40	149
Compact with IFC 100 ②	-5	80	-40	65	23	176	-40	149

PU

Separate flow sensor	-5	65	-40	65	23	149	-40	149
Compact with IFC 300	-5	65	-40	65	23	149	-40	149
Compact with IFC 100	-5	65	-40	65	23	149	-40	149

① 140°C / 284°F if ambient temperature ≤ 40°C / 104°F.

② Hardrubber liner is available for Ex-versions only

3.5 Mounting

3.5.1 Torques and pressures

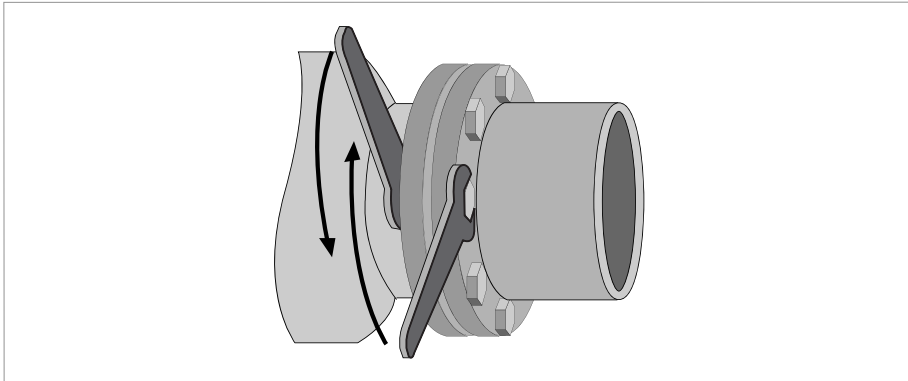

Figure 3-14: Tightening of bolts



Tightening of bolts

- ① Step 1: Apply approx. 50% of max. torque given in table.
- ② Step 2: Apply approx. 80% of max. torque given in table.
- ③ Step 3: Apply 100% of max. torque given in table.

Nominal size DN [mm]	Pressure rating	Bolts	Max. torque [Nm]	
			PFA, PTFE, ETFE	PU, hardrubber
2.5	PN 40	4 × M 12	32	-
4	PN 40	4 × M 12	32	-
6	PN 40	4 × M 12	32	-
10	PN 40	4 × M 12	7.6	4.6
15	PN 40	4 × M 12	9.3	5.7
20	PN 40	4 × M 12	16	9.6
25	PN 40	4 × M 12	22	11
32	PN 40	4 × M 16	37	19
40	PN 40	4 × M 16	43	25
50	PN 40	4 × M 16	55	31
65	PN 16	4 × M 16	51	42
65	PN 40	8 × M 16	38	21
80	PN 10	8 × M 16	47	25
100	PN 16	8 × M 16	39	30
125	PN 16	8 × M 16	53	40
150	PN 16	8 × M 20	68	47
200	PN 10	8 × M 20	84	68
200	PN 16	12 × M 20	68	45
250	PN 10	12 × M 20	78	65
250	PN 16	12 × M 24	116	78
300	PN 10	12 × M 20	88	76
300	PN 16	12 × M 24	144	105
350	PN 10	16 × M 20	97	75
400	PN 10	16 × M 24	139	104
450	PN 10	20 × M 24	127	93
500	PN 10	20 × M 24	149	107
600	PN 10	20 × M 27	205	138
700	PN 10	20 × M 27	238	163
800	PN 10	24 × M 30	328	219
900	PN 10	28 × M 30	-	205
1000	PN 10	28 × M 35	-	261

Nominal size [inch]	Flange class [lbs]	Bolts	Max. torque [Nm]	
			PFA, PTFE, ETFE	PU, hardrubber
1/10	150	4 × 1/2"	32	-
1/6	150	4 × 1/2"	32	-
1/4	150	4 × 1/2"	32	-
3/8	150	4 × 1/2"	3.5	3.6
1/2	150	4 × 1/2"	3.5	3.6
3/4	150	4 × 1/2"	4.8	4.8
1	150	4 × 1/2"	6.7	4.4
1 1/2	150	4 × 1/2"	13	12
2	150	4 × 5/8"	24	23
3	150	4 × 5/8"	43	39
4	150	8 × 5/8"	34	31
6	150	8 × 3/4"	61	51
8	150	8 × 3/4"	86	69
10	150	12 × 7/8"	97	79
12	150	12 × 7/8"	119	104
14	150	12 × 1"	133	93
16	150	16 × 1"	130	91
18	150	16 × 1 1/8"	199	143
20	150	20 × 1 1/8"	182	127
24	150	20 × 1 1/4"	265	180
28	150	28 × 1 1/4"	242	161
32	150	28 × 1 1/2"	380	259
36	150	32 × 1 1/2"	-	269
40	150	36 × 1 1/2"	-	269

4.1 Safety instructions



DANGER!

All work on the electrical connections may only be carried out with the power disconnected. Take note of the voltage data on the nameplate!



DANGER!

Observe the national regulations for electrical installations!



DANGER!

For devices used in hazardous areas, additional safety notes apply; please refer to the Ex documentation.



WARNING!

Observe without fail the local occupational health and safety regulations. Any work done on the electrical components of the measuring device may only be carried out by properly trained specialists.



INFORMATION!

Look at the device nameplate to ensure that the device is delivered according to your order. Check for the correct supply voltage printed on the nameplate.

4.2 Grounding



DANGER!

The device must be grounded in accordance with regulations in order to protect personnel against electric shocks.

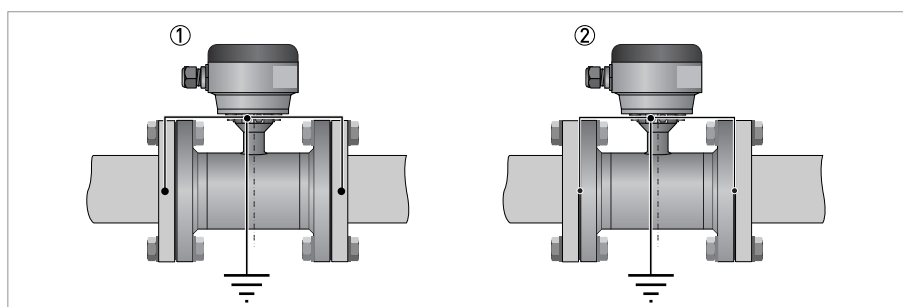

Figure 4-1: Grounding

- ① Metal pipelines, not internally coated. Grounding without grounding rings.
- ② Metal pipelines with internal coating and non-conductive pipelines. Grounding with grounding rings.

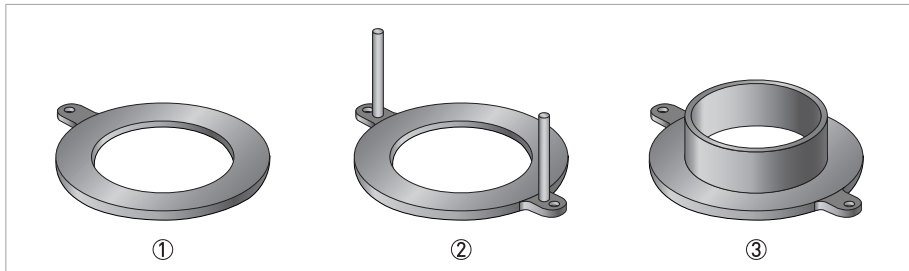

Figure 4-2: Different types of grounding rings

- ① Grounding ring number 1
- ② Grounding ring number 2
- ③ Grounding ring number 3

Grounding ring number 1:

- 3 mm / 0.1" thick (tantalum: 0.5 mm / 0.1")

Grounding ring number 2:

- 3 mm / 0.1" thick
- Prevents damage to the flanges during transport and installation
- Especially for flow sensors with PTFE liner

Grounding ring number 3:

- 3 mm / 0.1" thick
- With cylindrical neck (length 30 mm / 1.25" for DN10...150 / 3/8...6")
- Prevents damage to the liner when abrasive liquids are used

4.3 Virtual reference for IFC 300 (C, W and F version)

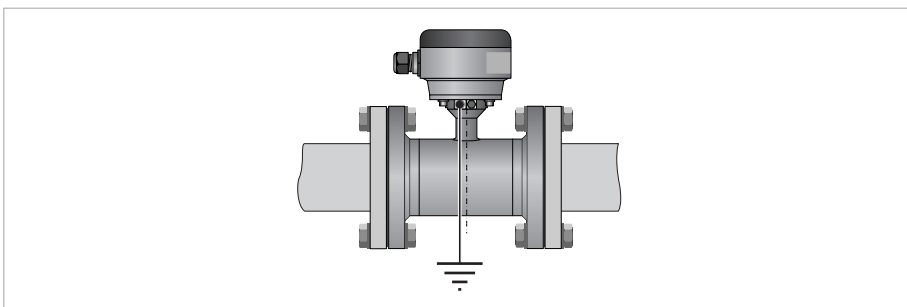

Figure 4-3: Virtual reference

Possible if:

- \geq DN10
- Electrical conductivity \geq 200 μ S/cm
- Electrode cable max. 50m.

5.1 Spare parts availability

The manufacturer adheres to the basic principle that functionally adequate spare parts for each device or each important accessory part will be kept available for a period of 3 years after delivery of the last production run for the device.

This regulation only applies to spare parts which are under normal operating conditions subjects to wear and tear.

5.2 Availability of services

The manufacturer offers a range of services to support the customer after expiration of the warranty. These include repair, technical support and training.



INFORMATION!

For more precise information, please contact your local representative.



INFORMATION!

Before calling the customer support, please collect the information which are listed in the support information form (see appendix) and have it at hand.

5.3 Returning the device to the manufacturer

5.3.1 General information

This device has been carefully manufactured and tested. If installed and operated in accordance with these operating instructions, it will rarely present any problems.



CAUTION!

Should you nevertheless need to return a device for inspection or repair, please pay strict attention to the following points:

- *Due to statutory regulations on environmental protection and safeguarding the health and safety of our personnel, manufacturer may only handle, test and repair returned devices that have been in contact with products without risk to personnel and environment.*
- *This means that the manufacturer can only service this device if it is accompanied by the following certificate (see next section) confirming that the device is safe to handle.*



CAUTION!

If the device has been operated with toxic, caustic, flammable or water-endangering products, you are kindly requested:

- *to check and ensure, if necessary by rinsing or neutralizing, that all cavities are free from such dangerous substances,*
- *to enclose a certificate with the device confirming that is safe to handle and stating the product used.*

5.3.2 Form (for copying) to accompany a returned device

Company:		Address:	
Department:		Name:	
Tel. no.:		Fax no.:	
Manufacturer's order no. or serial no.:			
The device has been operated with the following medium:			
This medium is:	water-hazardous		
	toxic		
	caustic		
	flammable		
	We checked that all cavities in the device are free from such substances.		
	We have flushed out and neutralized all cavities in the device.		
We hereby confirm that there is no risk to persons or the environment through any residual media contained in the device when it is returned.			
Date:		Signature:	
Stamp:			

5.4 Disposal



CAUTION!

Disposal must be carried out in accordance with legislation applicable in your country.

6.1 Measuring principle

An electrically conductive fluid flows inside an electrically insulating pipe through a magnetic field. This magnetic field is generated by a current, flowing through a pair of field coils. Inside of the fluid, a voltage U is generated:

$$U = v * k * B * D$$

in which:

v = mean flow velocity

k = factor correcting for geometry

B = magnetic field strength

D = inner diameter of flow meter

The signal voltage U is picked off by electrodes and is proportional to the mean flow velocity v and thus the flow rate q . The signal voltage is quite small (typically 1 mV at $v = 3$ m/s / 10 ft/s and field coil power of 1 W). Finally, a signal converter is used to amplify the signal voltage, filter it (separate from noise) and convert it into signals for totalising, recording and output processing.

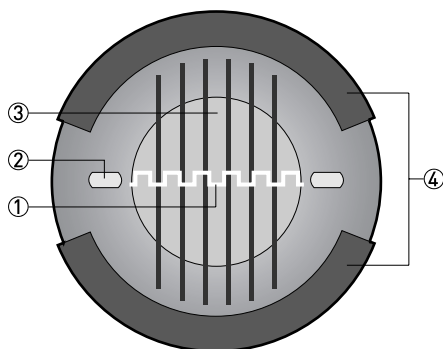

- ① Induced voltage (proportional to flow velocity)
- ② Electrodes
- ③ Magnetic field
- ④ Field coils

6.2 Technical data



INFORMATION!

- The following data is provided for general applications. If you require data that is more relevant to your specific application, please contact us or your local representative.
- Additional information (certificates, special tools, software,...) and complete product documentation can be downloaded free of charge from the website (Download Center).

Measuring system

Measuring principle	Faraday's law
Application range	Electrically conductive fluids
Measured value	
Primary measured value	Flow velocity
Secondary measured value	Volume flow, mass flow, electrical conductivity, coil temperature

Design

Features	Flange version with full bore flow tube
	Standard as well as higher pressure ratings
	Broad range of nominal sizes
	Industry specific insertion lengths
Modular construction	The measurement system consists of a flow sensor and a signal converter. It is available as compact and as separate version. More information about the signal converter can be found in the documentation of the signal converter.
Compact version	With IFC 100 converter: OPTIFLUX 4100 C
	With IFC 300 converter: OPTIFLUX 4300 C
Remote version	In wall (W) mount version with IFC 100 converter: OPTIFLUX 4100 W
	In field (F), wall (W) or rack (R) mount version with IFC 300 converter: OPTIFLUX 4300 F, W or R
Nominal diameter	With IFC 100 converter: DN2.5...1200 / 1/10...48"
	With IFC 300 converter: DN2.5...3000 / 1/10...120"
Measurement range	-12...+12 m/s / -40...+40 ft/s

Measuring accuracy

Reference conditions	Medium: water
	Temperature: 20°C / 68°F
	Inlet section: 10 DN
	Outlet section: 5 DN
	Flow velocity: > 1 m/s / > 3 ft/s
	Operating pressure: 1 bar / 14.5 psig
	Valve closing time variation: < 1 ms
	Wet calibrated on EN 17025 accredited calibration rig by direct volume comparison
	Flow conditions: similar to EN 29104
Maximum measuring error	Related to volume flow (MV = Measured Value)
	These values are related to the pulse / frequency output
	The additional typical measuring deviation for the current output is $\pm 10 \mu\text{A}$
	With IFC 100 converter:
	DN2.5...6: $\pm 0.4\%$ of MV + 1 mm/s
	DN10...1200: $\pm 0.3\%$ of MV + 1 mm/s
	With IFC 300 converter:
	DN2.5...6: $\pm 0.3\%$ of MV + 2 mm/s
	DN10...1600: $\pm 0.2\%$ of MV + 1 mm/s
DN1800...3000: $\pm 0.3\%$ of MV + 2 mm/s	
Repeatability	$\pm 0.1\%$ of MV, minimum 1 mm/s
Long term stability	$\pm 0.1\%$ of MV
Special calibration	Better accuracies optional

Operating conditions

Temperature	
Process temperature	Temperature depends on the liner material.
	PTFE: -40...+180°C / -40...+356°F (remote versions, compact versions are limited to +140°C / 284°F).
	PFA: -40...+180°C / -40...+356°F (remote versions, compact versions are limited to +140°C / 284°F).
	ETFE: -40...+120°C / -40...+248°F
	Hard rubber: -5...+80°C / 23...+176°F
	PU: -5...+65°C / 23...+149°F
	For Ex versions different temperatures count. Please see the relevant Ex documentation for details.
	For detailed information see chapter "Temperatures".
Ambient temperature	Non-Ex: -40...+65°C / -40...+149°F
	Ex: -40...+60°C / -40...+140°F
Storage temperature	-50...+70°C / -58...+158°F

Pressure	
Ambient	Atmospheric
Nominal flange pressure	Information for sizes larger than DN2000 / ASME80" on request.
DIN (EN 1092-1)	Standard:
	PN 6 for DN1200...2000
	PN 10 for DN200...1000
	PN 16 for DN65 and DN100...150
	PN 40 for DN2.5...50 and DN80
	Option:
	PN 10 for DN1200...2000
	PN 16 for DN200...2000
	PN 25 for DN65 and DN100...1000
	PN 40 for DN65 and DN100...600
Other pressures on request	
ISO insertion length	Optional for DN15...600
ASME B16.5	Standard:
	150 lbs RF for ASME1/10...24"
	Option:
	300 lbs RF for ASME1/10...24"
	600 lbs RF for ASME3/8...24"
	900 lbs RF for ASME3/8...12"
	1500 lbs RF for ASME3/8...12"
Other pressures on request	
JIS	Standard:
	10 K for DN50...1000
	20 K for DN2.5...40
	Option:
	20 K for DN200...600
Other pressures on request	
Vacuum load	For information on pressure limits depending on liner material see chapter "Vacuum load".
Pressure ranges for secondary containment	Pressure resistant up to 40 bar / 580 psi
	Burst pressure up to approx. 160 bar / 2320 psi

Chemical properties	
Physical condition	Liquids
Electrical conductivity	Water: $\geq 20 \mu\text{S/cm}$
	Non water: $\geq 1 \mu\text{S/cm}$
Permissible gas content (volume)	$\leq 5\%$
Permissible solid content (volume)	$\leq 70\%$
Recommended flow velocity	-12...+12 m/s / -40...+40 ft/s
Other conditions	

Installation conditions

Inlet run	$\geq 5 \text{ DN}$ (without disturbing flow, after a single 90° bend)
	$\geq 10 \text{ DN}$ (after a double bend $2 \times 90^\circ$)
	$\geq 10 \text{ DN}$ (behind a control valve)
Outlet run	$\geq 2 \text{ DN}$
Dimensions and weights	For detailed information see chapter "Dimensions and weights".

Materials

Sensor housing	DN2.5...15: Stainless steel 1.4408
	DN20: GTW-S 30
	DN25...2000: Standard sheet steel, optional stainless steel 304 (1.4306)
	Other materials on request.
Flange	Standard: carbon steel, PU coated
	Option: stainless steel
	Other materials on request
Liner	PTFE: standard for DN20, optional for DN200...600
	PFA: standard for DN2.5...12 and DN25...150
	ETFE: standard for DN200...2000
	PU: optional for DN200...1800
	hard rubber: optional for DN200...2000 (Ex only)
	Other materials on request.
Grounding rings	Stainless steel, Hastelloy [®] C, Titanium, Tantalum
	Other materials on request
	Also available as alternative for grounding rings (IFC 300 only): Virtual Reference.
Connection box	F versions only
	Standard: Aluminum, polyurethane coated
	Option: Stainless steel 304 (1.4306)
Measuring electrodes	Standard: Hastelloy [®] C
	Option: Platinum, Stainless steel, Titanium, Tantalum (DN2.5...1200), low noise Hastelloy [®] C4 (DN10...2000), Low noise SS 316 Ti (1.4571) (DN10...2000)
	Other materials on request.
Grounding electrodes (option)	Same material as measuring electrodes.

Process connections

DIN	DN2.5...3000 in PN 2.5...40 (others on request)
ASME	1/10...120" in 150...2500 lbs RF (others on request)
JIS	DN2.5...1000 in JIS 10...20 K (others on request)
Design of gasket surface	RF (others on request)

Electrical connections

Signal cable	Only for remote systems
Type A	Standard cable, double shielded. Max. length: 600 m / 1950 ft (dep. on electrical conductivity and measuring sensor). See documentation of the converter for more information.
Type B	Optional cable, triple shielded. Max. length: 600 m / 1950 ft (dep. on electrical conductivity and measuring sensor). See documentation of the converter for more information.

Approvals and certifications**CE**

CE Sign	This device fulfills the statutory requirements of the EC directives. The manufacturer certifies successful testing of the product by applying the CE mark.
Electromagnetic compatibility	Directive: 2004/108/EC, NAMUR NE21/04
	Harmonized standard: EN 61326-1 : 2006
Low Voltage Directive	Directive: 2006/95/EC
	Harmonized standard: EN 61010 : 2001
Pressure Equipment Directive	Directive: 97/23/EC
	Category I, II or SEP
	Fluid group 1
	Production module H

Hazardous areas	
ATEX	with IFC 100 converter:
	KEMA 08 ATEX 0157 X / KEMA 04 ATEX 2125 X
	II 2 G Ex e ia mb IIC T4
	II 2 G Ex d ia mb T4
	II 2 G Ex e ia mb q T4...T3
	II 2 D Ex tD A21 IP64 T120°C
	with IFC 300 converter:
	KEMA 04 ATEX 2077 X / KEMA 04 ATEX 2125 X
	II 2 GD EEx me ia IIC
	II 2 GD EEx de ia IIC
	II 2 GD EEx qe ia IIC
	II 2 GD EEx e ia IIC
	T6...T3 or T5...T3
	For more details, see Ex documentation of sensor and converter.
FM	Class I, Div 2, groups A, B, C and D
	Class II, Div 2, groups F and G
	Class III, Div 2, groups F and G
CSA	Class I, Div 2, groups A, B, C and D
	Class II, Div 2, groups F and G
IEC-Ex	pending
NEPSI	GYJ05234 / GYJ05237
	Ex me ia IIC T6...T3
	Ex de ia II T6...T3
	Ex qe ia IIC T6...T3
	Ex e ia IIC T6...T3
Other approvals and standards	
Custody transfer	Standard: without
	Option: MI-001, MI-005, OIML R-49, OIML R-117
Hygiene	PFA liner is FDA approved.
Protection category acc. to IEC 529 / EN 60529	Standard: IP 66/67 (NEMA 4/4X/6)
	Optional: IP 68 (NEMA 6P)
Vibration resistance	IEC 68-2-6
Random vibration test	IEC 68-2-34
Shock test	IEC 68-2-27

6.3 Vacuum load

Diameter	Max. pressure	Vacuum load in mbar abs. at a process temperature of								
[mm]	[bar]	40°C	60°C	70°C	80°C	90°C	100°C	120°C	140°C	180°C
Liner in PFA										
DN2.5...150	50	0	0	0	0	0	0	0	0	0
Liner in Hardrubber										
DN200...300	150	250	400	400	400	-	-	-	-	-
DN350...3000	150	500	600	600	600	-	-	-	-	-
Liner in ETFE										
DN200...2000	150	100	100	100	100	100	100	100	-	-
Liner in PTFE										
DN10...20	50	0	0	0	0	0	0	500	750	1000
DN200...300	50	500	750	1000	1000	1000	1000	1000	1000	1000
DN350...600	50	800	1000	1000	1000	1000	1000	1000	1000	1000
Liner in PU										
DN200...1800	1500	500	600	-	-	-	-	-	-	-

Diameter	Max. pressure	Vacuum load in psia at a process temperature of								
[inches]	[psi]	104°F	140°F	158°F	176°F	194°F	212°F	248°F	284°F	356°F
Liner in PFA										
1/10...6"	725	0	0	0	0	0	0	0	0	0
Liner in Hardrubber										
8...12"	2176	3.6	5.8	5.8	5.8	-	-	-	-	-
14...120"	2176	7.3	8.7	8.7	8.7	-	-	-	-	-
Liner in ETFE										
8...72"	2176	1.5	1.5	1.5	1.5	1.5	1.5	1.5	-	-
Liner in PTFE										
3/8...3/4"	725	0	0	0	0	0	0	7.3	10.9	14.5
8...12"	725	7.3	10.9	14.5	14.5	14.5	14.5	14.5	14.5	14.5
14...24"	725	11.6	14.5	14.5	14.5	14.5	14.5	14.5	14.5	14.5
Liner in PU										
8...72"	21756	7.3	8.7	-	-	-	-	-	-	-

6.4 Dimensions and weights

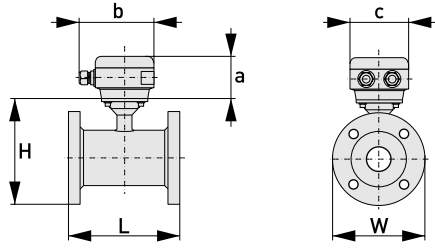
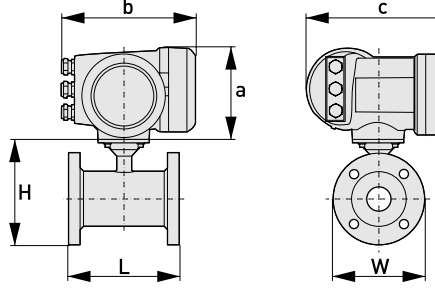
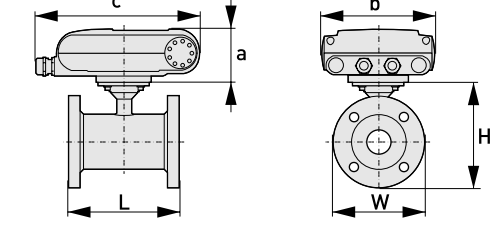
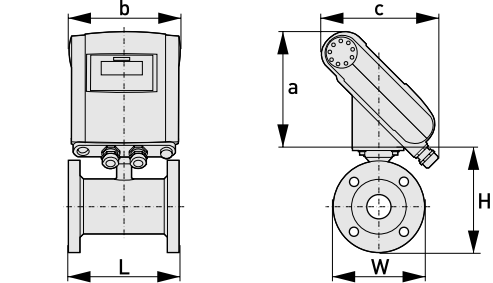
Remote version		<p>a = 77 mm / 3.1"</p> <p>b = 139 mm / 5.5" ①</p> <p>c = 106 mm / 4.2"</p> <p>Total height = H + a</p>
Compact version with IFC 300		<p>a = 155 mm / 6.1"</p> <p>b = 230 mm / 9.1" ①</p> <p>c = 260 mm / 10.2"</p> <p>Total height = H + a</p>
Compact version with IFC 100 (0°)		<p>a = 82 mm / 3.2"</p> <p>b = 161 mm / 6.3"</p> <p>c = 257 mm / 10.1" ①</p> <p>Total height = H + a</p>
Compact version with IFC 100 (45°)		<p>a = 186 mm / 7.3"</p> <p>b = 161 mm / 6.3"</p> <p>c = 184 mm / 7.3" ①</p> <p>Total height = H + a</p>

① The value may vary depending on the used cable glands.

**INFORMATION!**

- All data given in the following tables are based on standard versions of the sensor only.
- Especially for smaller nominal sizes of the sensor, the converter can be bigger than the sensor.
- Note that for other pressure ratings than mentioned, the dimensions may be different.
- For full information on converter dimensions see relevant documentation.

DIN/ISO flanges

Nominal size		Dimensions [mm]				Approx. weight [kg]
DN	PN [bar]	L		H	W	
		DIN	ISO			
2.5	40	130	-	142	90	3
4	40	130	-	142	90	3
6	40	130	-	142	90	3
10	40	130 ①	-	106	90	6
15	40	130 ①	200	106	95	6
20	40	150	200	158	105	7
25	40	150	200	140	115	5
32	40	150	200	157	140	6
40	40	150	200	166	150	7
50	40	200	200	186	165	11
65	16	200	200	200	185	9
80	40	200	200	209	200	14
100	16	250	250	237	220	15
125	16	250	250	266	250	19
150	16	300	300	300	285	27
200	10	350	350	361	340	34
250	10	400	450	408	395	48
300	10	500	500	458	445	58
350	10	500	550	510	505	78
400	10	600	600	568	565	101
450	10	600	-	618	615	111
500	10	600	-	671	670	130
600	10	600	-	781	780	165
700	10	700	-	898	895	248
800	10	800	-	1012	1015	331
900	10	900	-	1114	1115	430
1000	10	1000	-	1225	1230	507
1200	6	1200	-	1417	1405	555
1400	6	1400	-	1619	1630	765
1600	6	1600	-	1819	1830	1035
1800	6	1800	-	2027	2045	1470
2000	6	2000	-	2259	2265	1860

① 150 mm for construction according to order code VN03.

150 lbs flanges

Nominal size		Dimensions [inches]			Approx. weight [lbs]
ASME	PN [psi]	L	H	W	
1/10"	284	5.12	5.59	3.50	6
1/8"	284	5.12	5.59	3.50	6
1/4"	284	5.12	5.59	3.50	6
3/8"	284	5.12 ①	5.08	3.50	12
1/2"	284	5.12 ①	5.08	3.50	12
3/4"	284	5.91	5.28	3.88	18
1"	284	5.91	5.39	4.25	18
1 1/4"	284	5.91	5.98	4.62	15
1 1/2"	284	5.91	6.10	5.00	22
2"	284	7.87	7.05	5.98	29
3"	284	7.87	8.03	7.50	37
4"	284	9.84	9.49	9.00	51
5"	284	9.84	10.55	10.0	60
6"	284	11.81	11.69	11.0	75
8"	284	13.78	14.25	13.5	95
10"	284	15.75	16.3	16.0	143
12"	284	19.69	18.78	19.0	207
14"	284	27.56	20.67	21.0	284
16"	284	31.50	22.95	23.5	364
18"	284	31.50	24.72	25.0	410
20"	284	31.50	26.97	27.5	492
24"	284	31.50	31.38	32.0	675

① 5.91" for construction according to order code VN03

**CAUTION!**

- Pressures at 20°C / 68°F.
- For higher temperatures, the pressure and temperature ratings are as per ASME B16.5 (up to 24") or ASME B16.47 (>24").
- Dimensions for other sizes on request.

300 lbs flanges

Nominal size		Dimensions [inches]			Approx. weight [lbs]
ASME	PN [psi]	L	H	W	
1/10"	741	5.12	5.59	3.75	6
1/8"	741	5.12	5.59	3.75	6
1/4"	741	5.12	5.59	3.75	6
3/8"	741	5.12 ①	5.24	3.75	15
1/2"	741	5.12 ①	5.24	3.75	15
3/4"	741	5.91	5.67	4.62	20
1"	741	5.91	5.71	4.87	18
1 1/2"	741	7.87	6.65	6.13	20
2"	741	9.84	7.32	6.50	29
3"	741	9.84	8.43	8.25	37
4"	741	11.81	10.00	10.0	51
6"	741	12.60	12.44	12.5	79
8"	741	15.75	15.04	15.0	157
10"	741	19.69	17.05	17.5	247
12"	741	23.62	20.00	20.5	375
14"	741	27.56	21.65	23.0	474
16"	741	31.50	23.98	25.5	639
20"	741	31.50	28.46	30.5	937
24"	741	31.50	33.39	36.0	1345

① 5.91" for construction according to order code VN03

**CAUTION!**

- Pressures at 20°C / 68°F.
- For higher temperatures, the pressure and temperature ratings are as per ASME B16.5 (up to 24") or ASME B16.47 (>24").
- Dimensions for other sizes on request.







KROHNE product overview

- Electromagnetic flowmeters
- Variable area flowmeters
- Ultrasonic flowmeters
- Mass flowmeters
- Vortex flowmeters
- Flow controllers
- Level meters
- Temperature meters
- Pressure meters
- Analysis products
- Measuring systems for the oil and gas industry
- Measuring systems for sea-going tankers

Head Office KROHNE Messtechnik GmbH
Ludwig-Krohne-Str. 5
D-47058 Duisburg (Germany)
Tel.: +49 (0)203 301 0
Fax: +49 (0)203 301 10389
info@krohne.de

The current list of all KROHNE contacts and addresses can be found at:
www.krohne.com

KROHNE