



H250 Technical Datasheet

Variable area flowmeter

- Sturdy construction for high pressure, temperature and media resistance
- Simple to install - Measure and display without auxiliary power supply
- Modular and adaptable to meet customer-specific applications



1	Product features	3
<hr/>		
1.1	The standard solution for the process industry.....	3
1.2	Options and variants.....	5
1.3	Operating principle.....	8
2	Technical data	9
<hr/>		
2.1	Technical data.....	9
2.2	Dimensions and weights.....	20
2.3	Measuring ranges.....	24
3	Installation	32
<hr/>		
3.1	Intended use.....	32
3.2	Installation conditions.....	33
3.2.1	Magnetic filters.....	34
3.2.2	Heat insulation.....	35
3.2.3	Float damping.....	36
3.2.4	Pointer damping.....	36
4	Electrical connections	37
<hr/>		
4.1	Electrical connection indicator M8.....	37
4.1.1	Indicator M8M - limit switches.....	37
4.1.2	Indicator M8E - current output.....	37
4.2	Electrical connection indicator M9.....	40
4.2.1	Indicator M9 - limit switches.....	40
4.2.2	Indicator M9 - current output ESK2A.....	43
4.2.3	Indicator M9 - Profibus PA (ESK3-PA).....	46
4.2.4	Indicator M9 - totalizer (ESK-Z).....	47
4.3	Electrical connection indicator M10.....	50
4.3.1	Indicator M10.....	50
4.3.2	Power supply - current output.....	50
4.3.3	Switching outputs B1 and B2.....	53
4.3.4	Switching output B2 as a pulse output.....	55
4.3.5	Connection reset input R.....	56
5	Order form	57
<hr/>		
6	Notes	58
<hr/>		

1.1 The standard solution for the process industry

The all-metal variable area flowmeter H250 is used for flow measurement of conductive and non-conductive liquids, gases and vapours.



- ① 4...20 mA output / Profibus PA
- ② Limit switch
- ③ Flow counter

Highlights

- Simple, low-cost installation: Measure and display without auxiliary power supply
- Rugged stainless steel construction for high operating pressure up to 3000 bar / 44100 psi and extreme process temperatures of -200...+400°C / -328...+752°F
- Optionally available with PTFE/ceramic liner for acids and alkalis
- High application safety, even with extremely low flows
- Excellent long-term stability
- Modular and flexible to adapt to customer-specific applications
- SIL 2 certified
- International approvals for use in hazardous areas and nuclear power plants

Industries

Can be used in all industrial sectors, for example:

- Chemicals
- Petrochemicals
- Pharmaceutical
- Machinery
- Food & Beverage
- Oil & Gas
- Iron, Steel & Metals
- Power plants
- Pulp & Paper
- Water & Wastewater

Applications

- Continuous gas and liquid measurement
- Measurement of conductive and non-conductive media
- Industrial burner controlling
- Compressor monitoring
- Dry-run protection of pumps

1.2 Options and variants

Stainless steel indicator housing (H250/M9R)



For particularly rough environmental conditions, the M9 indicator housing is optionally available in stainless steel.

This guarantees its reliable use in corrosive atmospheres caused by operational emissions.

When installed outdoors, external influences such as salt fog or contaminated precipitation no longer lead to corrosion.

The stainless steel housing is equally well-suited for use in splash water zones such as in the food and luxury food industry.

FOOD & PHARMA (H250 F)



The only EHEDG-certified variable area flowmeter approved for used in the food and pharmaceuticals industry.

Smooth stainless steel surfaces with a surface roughness of $\leq 0.8 \mu\text{m}$ or $0.6 \mu\text{m}$ of the wetted parts make deposition difficult and are very easy to clean.

Combined with a design featuring no dead spaces or stagnation zones, micro-organisms have no chance to adhere and multiply.

The measuring devices can be cleaned (CIP) and sterilised (SIP) in place.

Suitable connections and FDA conforming materials for the food and pharmaceutical industry are available.

PTFE/ceramic liner for aggressive media



All wetted parts are made of PTFE or ceramic and can thus be used for almost all acids and alkalis.

Depending on the choice of material, the measuring device can be used up to a maximum temperature of 70°C / 158°F (PTFE) or 250°C / 482°F (ceramic).

Versions for special installation positions (H250H / H250U)



Variable area flowmeters typically feature a vertically positioned measuring cone through which the medium flows from bottom to top, lifting a float against the weight.

If the installation structure does not permit otherwise, versions for horizontal or inverted (from top to bottom) installation positions are used.

The missing reset force of the variable area float weight is replaced by a spring.

Indicator variants

Indication M9 (modular)



- Local indication without auxiliary power supply
- 2 limit switches (NAMUR or 3-wire transistor)
- 2-wire current output 4...20 mA with HART®
- Profibus PA interface
- 6-digit flow counter with pulse output (non Ex)
- Intrinsically safe Ex i (ATEX, FM, NEPSI)

Indicator M10 (integrated)



- Graphic display for measured value and counter display
- 2 limit switches (NAMUR or open collector transistor)
- 2-wire current output 4...20 mA with HART®
- 12-digit flow counter with pulse output and reset input
- Explosion proof enclosure Ex d (ATEX, FM, CSA, NEPSI)

Indicator M8 (compact)



- Compact, space saving design
- Intrinsically safe Ex i (ATEX)

M8M

- Mechanical indicator without auxiliary power
- 2 limit switches (NAMUR)

M8E

- Electronic bargraph indicator
- 2-wire current output 4...20 mA with HART®

1.3 Operating principle

The flowmeter H250 operates on the float measuring principle. The measuring unit consists of a metal cone in which a float can move freely up and down. The medium flows through the flowmeter from bottom to top. The float adjusts itself so that the buoyancy force **B**, acting on it, the form drag **D** and its weight **W** are in equilibrium: $W = B + D$.

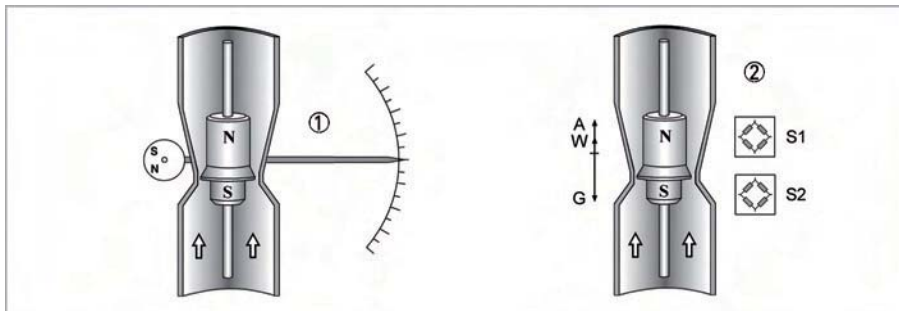

Figure 1-1: Operating principle

- ① Indication principle M9 and M8MG
- ② Indication principle M10 and M8EG

For indicators M9 and M8MG ① the flow-dependent height of the float in the measuring unit is transmitted by means of a magnetic coupling and displayed on a scale. For indicators M10 and M8EG ② the flow-dependent height of the float in the measuring unit is transmitted to the electronic display by means of a magnetic coupling on sensors S1 and S2.

Operating principle of H250H and H250U

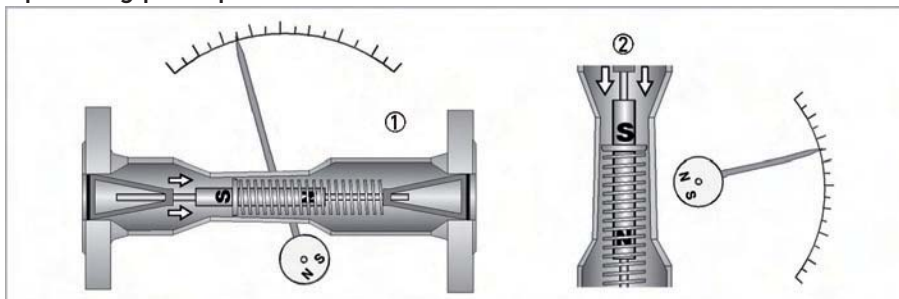

Figure 1-2: Operating principle H250H and H250U

- ① H250H - horizontal flow direction
- ② H250U - flow direction from top to bottom

The flowmeters operate according to a modified float measuring principle. The guided float adjusts itself so that the flow force acting on it is in equilibrium with the opposing spring force. The flow-dependent position of the float in the measuring unit is displayed on a scale by means of a magnetic coupling.

Flowmeters H250H and H250U only work in conjunction with indicator M9.

2.1 Technical data

- *The following data is provided for general applications. If you require data that is more relevant to your specific application, please contact us or your local representative.*
- *Additional information (certificates, special tools, software,...) and complete product documentation can be downloaded free of charge from the website (Downloadcenter).*

Measuring system

Application range	Flow measurement of liquids, gases and vapors
Operating method / measuring principle	Variable area measuring principle
Measured value	
Primary measured value	Float position
Secondary measured value	Operating and standard volumetric flow

Measuring accuracy

Directive	VDI / VDE 3513, sheet 2 (q _G = 50%)
H250 /RR /HC /F	1.6%
H250/C (Ceramic, PTFE) H250H, H250U, H250 (100 : 1)	2.5%

Operating conditions

Temperature	
Max. operating temperature TS	-196..+300°C / -321...+572°F
Pressure	
Max. operating pressure PS	Depending on the version up to 400 bar / 5802 psig
Max. test pressure PT	Pressure equipment directive 97/23/EC or AD 2000-HP30
Min. required operating pressure	2 times greater than pressure loss (see measuring ranges)
Float damping during gas measurement recommended:	
DN15...25 / ½" ...1"	Operating pressure <0.3 bar / 4.4 psig
DN50...100 / 2" ...4"	Operating pressure <0.2 bar / 2.9 psig

Installation conditions

Inlet run	≥ 5 x DN
Outlet run	≥ 3 x DN

Materials

Device	Flanges / raised face	Measuring tube	Float	Float stop / guide	Ring orifice
H250 /RR Stainless Steel	CrNi steel 1.4404 massive ①	CrNi steel 1.4404 ①			-
H250/HC Hastelloy®	CrNi steel 1.4571 with plated Hastelloy® C4 (2.4610) ①	Hastelloy® C4 (2.4610)			-
H250/C Ceramic/PTFE	CrNi steel 1.4571 with TFM/PTFE liner ②	PTFE or Al ₂ O ₃ with FFKM gasket	Al ₂ O ₃ and PTFE		Al ₂ O ₃
H250/F F - Food	CrNi steel 1.4435				-

① CrNi steel 1.4571 on request, for clamp connection CrNi steel 1.4435

② TFM/PTFE liner (electrically non-conductive)

H250/C - DN100 / 4" only PTFE

H250/F: wetted surfaces Ra ≤ 0.8 μm, optional ≤ 0.6 μm

Other options:

- Special materials on request: e.g. SMO 254, titanium, 1.4435
- Float damping: ceramic or PEEK
- Gasket for devices with female thread as insert: O-ring FPM / FKM

Temperatures

For devices to be used in hazardous areas, special temperature ranges apply. These can be found in the separate instructions.

Temperatures H250/M9 - mechanical indicator without power supply

	Float	Liner	Product temperature		Ambient temperature	
			[°C]	[°F]	[°C]	[°F]
H250/RR	Stainless Steel	Stainless Steel	-196...+300	-321...+572	-40...+120	-40...+248
H250/RR screw fitting					-20...+120	-4...+248
H250/HC	Hastelloy® C4	Hastelloy® C4	-196...+300	-321...+572	-40...+120	-40...+248
H250/C	PTFE	PTFE	-196...+70	-321...+158	-40...+70	-40...+158
H250/C	Ceramic	PTFE	-196...+150	-321...+302	-40...+70	-40...+158
H250/C	Ceramic	TFM	-196...+250	-321...+482	-40...+120	-40...+248
H250 H/U	Stainless Steel	Stainless Steel	-40...+100	-40...+212	-20...+90	-4...+194

Temperatures H250/M9 - with electrical components [°C]

Maximum product temperatures T_m			$T_{amb.} < +40^\circ\text{C}$		$T_{amb.} < +60^\circ\text{C}$ ①	
EN	ASME	Version with	Standard	HT	Standard	HT
DN15, DN25	½", 1"	ESK2A, ESK3-PA	+200	+300	+180	+300
		ESK2A with counter	+200	+300	+80	+130
		Limit switch NAMUR	+200	+300	+200	+300
		3-wire limit switch	+200	+300	+130	+295
DN50	2"	ESK2A, ESK3-PA	+200	+300	+165	+300
		ESK2A with counter	+180	+300	+75	+100
		Limit switch NAMUR	+200	+300	+200	+300
		3-wire limit switch	+200	+300	+120	+195
DN80, DN100	3", 4"	ESK2A, ESK3-PA	+200	+300	+150	+250
		ESK2A with counter	+150	+270	+70	+85
		Limit switch NAMUR	+200	+300	+200	+300
		3-wire limit switch	+190	+300	+110	+160

Temperatures H250/M9 - with electrical components [°F]

Maximum product temperatures T_m			$T_{amb.} < +104^\circ\text{F}$		$T_{amb.} < +104^\circ\text{F}$ ①	
EN	ASME	Version with	Standard	HT	Standard	HT
DN15, DN25	½", 1"	ESK2A, ESK3-PA	392	572	356	572
		ESK2A with counter	392	572	176	266
		Limit switch NAMUR	392	572	392	572
		3-wire limit switch	392	572	266	563
DN50	2"	ESK2A, ESK3-PA	392	572	165	572
		ESK2A with counter	356	572	167	212
		Limit switch NAMUR	392	572	392	572
		3-wire limit switch	392	572	248	383
DN80, DN100	3", 4"	ESK2A, ESK3-PA	392	572	302	482
		ESK2A with counter	302	518	158	185
		Limit switch NAMUR	392	572	392	572
		3-wire limit switch	374	572	230	320

① if there are no heat insulation measures, a heat-resistant cable is necessary (continuous operating temperature of the cable to be used: +100°C)

Abbreviation

HT	High-temperature version
ESK2A	Current output 2-wire 4...20 mA
ESK3-PA	PROFIBUS PA interface

Minimum ambient temperatures $T_{amb.}$ with ESK and limit switches

Device	[°C]	[°F]
Limit switch	-25 / -40	-13 / -40
ESK2A - ESK3-PA	-40	-40

Temperatures H250 /M8 /M10

	[°C]	[°F]
--	------	------

M8M

Min. product temperature T_m without limit switches	-80...+200	-112...+392
Min. product temperature T_m with limit switches	-25...+200	-13...+392
Ambient temperature $T_{amb.}$	-25...+70	-13...+158

M8E

Max. product temperature T_m at $T_{amb.}$ +40°C / +104°F	-25...+200	-13...+392
Max. product temperature T_m at $T_{amb.}$ +50°C / +122°F	-25...+185	-13...+365
Max. product temperature T_m at $T_{amb.}$ +60°C / +140°F	-25...+145	-13...+293
Ambient temperature $T_{amb.}$	-25...+70	-13...+158

M10

Max. product temperature T_m at $T_{amb.}$ +60°C / +140°F	-80...+200	-112...+392
Ambient temperature $T_{amb.}$	-40...+75	-40...+167

Indicator M8

M8M limit switches

Terminal connection	2.5 mm ²		
Limit switch	I7S2002-N SC2-N0	SJ2-SN	SJ2-S1N
Type	2-wire NAMUR	2-wire NAMUR ①	2-wire NAMUR ①
Switch configuration	NC contact	NC contact	NO contact
Nominal voltage U ₀	8 VDC	8 VDC	8 VDC
Pointer vane not read	≥ 3 mA	≥ 3 mA	≤ 1 mA
Pointer vane read	≤ 1 mA	≤ 1 mA	≥ 3 mA

① safety oriented

M8E current output

Cable gland	M16 x 1.5
Cable diameter	8...10 mm
Terminal connection	4 mm ²
Measuring signal	4...20 mA = 0...100 % flow value in 2-wire technology
Power supply	14.8...30 VDC
Min. power supply for HART®	20.5 VDC
Power supply influence	< 0.1%
Dependence on external resistance	< 0.1%
Temperature influence	< 10 µA / K
Max. external resistance / load	640 Ohm (30 VDC)
Min. load for HART®	250 Ohm

M8E HART® configuration

Manufacturer name (code)	KROHNE Messtechnik (69)
Model name	M8E (230)
HART® protocol revision	5.1
Device revision	1
Physical layer	FSK
Device category	Transmitter

M8E process variable

M8E process variable flow rate	Values [%]	Signal output [mA]
Over range	+105 (±1%)	20.64...20.96
Device error identification	>110	>21.60
Maximum	112.5	22
Multidrop operation	-	4.5

Indicator M9

M9 cable glands

Cable gland	Material	Cable diameter	
M 16x1.5 Standard	PA	5...10 mm	0.197...0.394"
M20 x 1.5	PA	8...13 mm	0.315...0.512"
M 16x1.5	Nickel-plated brass	5...9 mm	0.197...0.355"
M20 x 1.5	Nickel-plated brass	10...14 mm	0.394...0.552"

M9 limit switches

Terminal connection	2.5 mm ²			
Limit switch	I7S23,5-N SC3,5-N0	SJ3,5-SN ①	SJ3,5-S1N ①	SB3,5-E2
Type	2-wire NAMUR	2-wire NAMUR	2-wire NAMUR	3-wire
Switching element function	NC contact	NC contact	NO contact	PNP NO contact
Nominal voltage U ₀	8 VDC	8 VDC	8 VDC	10...30 VDC
Pointer vane not detected	≥ 3 mA	≥ 3 mA	≤ 1 mA	≤ 0.3 VDC
Pointer vane detected	≤ 1 mA	≤ 1 mA	≥ 3 mA	U _B - 3 VDC
Continuous current	-	-	-	max. 100 mA
No load current I ₀	-	-	-	≤ 15 mA

① safety oriented

M9 current output ESK2A

Terminal connection	2.5 mm ²
Power supply	12...30 VDC
Min. power supply for HART®	18 VDC
Measuring signal	4.00...20.00 mA = 0...100% flow value in 2-wire technology
Power supply influence	<0.1%
Dependence on external resistance	<0.1%
Temperature influence	5 µA / K
Max. external resistance / load	800 Ohm (30 VDC)
Min. load for HART®	250 Ohm
Software firmware version	02.15
Ident No.	4000054602
ESK2A HART® configuration	
Manufacturer name (code)	KROHNE Messtechnik (69 = 45h)
Model name	ESK2A (226 = E2h)
HART® protocol revision	5.9
Device revision	1
Physical layer	FSK
Device category	Transmitter without galvanic isolation

M9 ESK2A process variable

ESK2A process variable flow rate	Values [%]	Signal output [mA]
Over range	+102.5 ($\pm 1\%$)	20.24...20.56
Device error identification	> 106.25	>21.00
Maximum	131.25	25
Multidrop operation	-	4.5
Min. $U_{\text{ext.}}$	12 VDC	

M9 ESK-Z totalizer

Terminal connection	2.5 mm ²
Power supply	10...30 VDC
$R_{\text{ext.}}$ current loop	0...600 Ohm
Power consumption	max. 2.5 Watt
Indication error	< 1% in relation to the value displayed
Max. reset voltage	30 VDC
Min. reset pulse	300 ms
Software firmware version	1.19
Power supply	10...30 VDC
Max. current	50 mA
Max. dissipation	250 mW
T on	80 ms fixed pulse width
T off	depending on flow rate
U on	$U_b - 3$ VDC
U off	0 VDC
Pulse value	1 pulse = 1 display counter advance (1 litre, 1 m ³ ...)

Indicator M9 ESK3-PA Profibus

Terminal connection	2.5 mm ²
Bus cable R´	15...150 Ohm/km
Bus cable L´	0.4...1 mH/km
Bus cable C´	80...200 nF/km

M9 ESK3PA Hardware

Hardware	acc. to IEC 1158-2 and FISCO model
Supply voltage	9...32 VDC
Base current	12 mA
Starting current	< base current
FDE (fault drop electronics)	< 18 mA
Accuracy acc. to VDI/ VDE 3513	1.6
Measurement resolution	< 0.1% full scale value
Temperature influence	< 0.05% / K full scale value
Software firmware version	1.01/000418
Ident No.	3184980200

M9 ESK3PA Software

GSD	Devices master file
Device profile	Profiles B, V3.0
Function blocks	
Flow rate (AI0)	Volume or mass
Totalizer (TOT0)	Volume totalizer Default unit: [m ³]
Totalizer (TOT1)	Mass totalizer Default unit: [kg]
Address range	0...126, default 126
SAP`s	Service Access Points
DD	Device Description

Indicator M10

M10 cable gland

(Standard)	without
M20 x 1.5	On request
M 20x1.5 Ex d	On request

M10 current output

Terminal connection	2.5 mm ²
Power supply	24 VDC ±30%
Min. power supply for HART®	18 VDC
Measuring signal	4.00...20.00 mA = 0...100% flow value in 2-wire technology
Power supply influence	< 0.1%
Dependence on external resistance	< 0.1%
Temperature influence	< 5 µA/K
Max. external resistance / load	≤ 630 Ohm
Min. load for HART	≥ 250 Ohm
Software firmware version	02.17
Ident No.	3209470500

M10 HART®

Manufacturer name (code)	KROHNE Messtechnik (69 = 45h)
Model name	M10 (234 = EA)
HART® protocol revision	5.9
Device revision	1
Physical layer	FSK
Device category	Transmitter

M10 process variable

	Values [%]	Signal output [mA]
Over range	+105 (±1%)	20,64...20.96
Device error identification	> 110	> 21.60
Maximum	112.5	22
Multidrop operation	-	4.5
Lift-off voltage	12 VDC	

M10 binary output

Two binary outputs	Galvanically isolated	
Operating mode	Switch output	NAMUR or open collector
Configurable as	Switch contact or pulse output	open / closed or max. 10 pulses / s
NAMUR switch output		
Power supply	8 VDC	
Signal current	> 3 mA switching value not reached;	< 1 mA switching value reached
Switch output, open collector		
Power supply	8...30 VDC	
P _{max}	500 mW	
I _{max}	100 mA	

M10 reset input

Binary input	Galvanically isolated
Operating mode	Reset counter
Configurable as	active Hi / active Lo
Voltage level	5...30 VDC
Current consumption	≤ 1 mA
Pulse length (active)	≥500 ms

Approvals

Standard	Indicator	Designation
ATEX	M9 mechanical	II2GD IIC II3GD IIC
	M9 electrical	II2G Ex ia IIC T6 II3G Ex nA II T6 II3D IP65 T65°C
	M8 mechanical	II2GD IIC II3GD IIC
	M8 electrical	II2G Ex ia IIC T6...T1
	M10	II2G Ex d IIC T6...T1 II3D Ex tD A22 IP66 T65°C
FM	M9	IS/I/1/ABCD;T6 NI/I/2/ABCD;T6 IS/I, II, III/1/A-G NI/II/2/ABCD
	M10	XP/I/1/ABCD;T6 NI/I/2/ABCD;T6 XP/I/1/IIC/T6 NI/I/2/IIC/T6 DIP/II,III/1/EFG/T6 S/II,III/2/FG/T6
CSA	M10	XP/I/1/ABCD;T6 NI/I/2/ABCD;T6 XP/I/1/IIC/T6 NI/I/2/IIC/T6 DIP/II,III/1/EFG/T6 S/II,III/2/FG/T6
Nepsi	M9	Ex ia IIC T1-T6 Ex nA II T1-T6
	M8	Ex ia IIC T1-T6
	M10	Ex d IIC T1-T6
INMETRO	M10	II2G EEx d IIC T6...T1

2.2 Dimensions and weights

Dimensions H250/M9

Front view

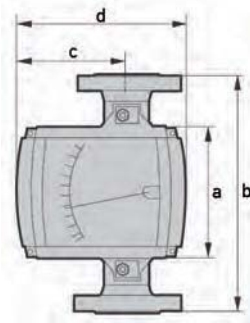

Side view

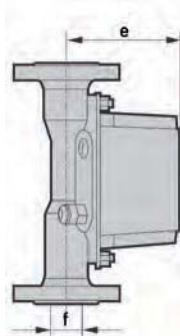

with heating

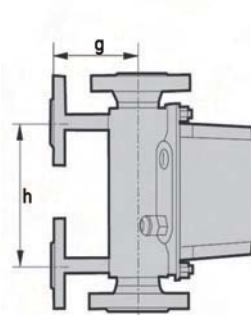

High-temperature

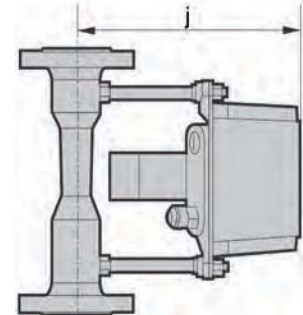

	a		b		d		h	
	[mm]	["]	[mm]	["]	[mm]	["]	[mm]	["]
All nominal sizes	138	5.44	250	9.85	181	7.13	150	5.91
ISO 228			300	11.82				
H250/C - 3"/300 lbs			300	11.82				

EN	ASME	c		e		Ø f		g		j	
		[mm]	["]	[mm]	["]	[mm]	["]	[mm]	["]	[mm]	["]
DN15	½"	110.5	4.35	107	4.22	20	0.79	100	3.94	187	7.37
DN25	1"	110.5	4.35	119	4.69	32	1.26	106	4.18	199	7.84
DN50	2"	123.5	5.22	132	5.20	65	2.56	120	4.73	212	8.35
DN80	3"	123.5	5.22	148	5.83	89	3.51	145	5.71	228	8.98
DN100	4"	123.5	5.22	158	6.22	114	4.49	150	5.91	232	9.14

ISO 228 female thread screwed

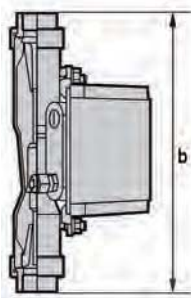

ISO 228 female thread welded

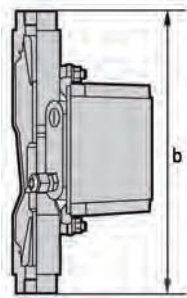

H250/F Clamp connection

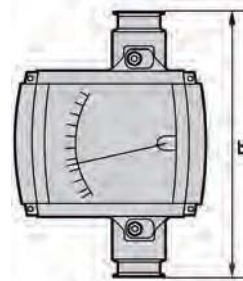

H250/F Screw connection DIN 11851

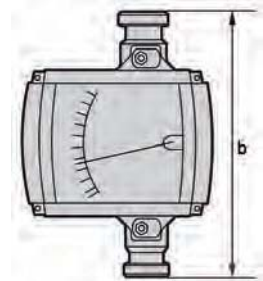

①

① Stainless steel 1.4435 - EHEDG tested - wetted surfaces Ra ≤ 0.8 / 0.6 µm

Dimensions H250/M10 /M8

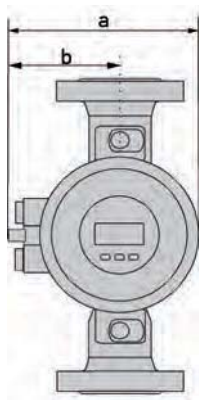
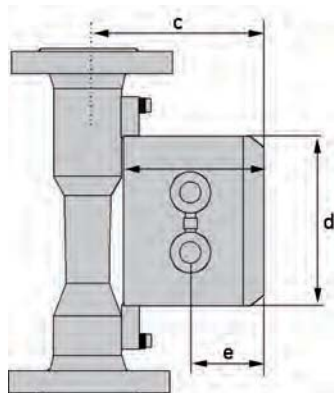
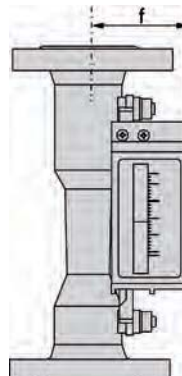
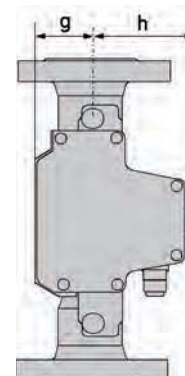
M10
Front viewM10
Side viewM8
Front viewM8
Side view

		Dimensions M10									
		a		b		c		Ø d		e	
EN	ASME	[mm]	["]	[mm]	["]	[mm]	["]	[mm]	["]	[mm]	["]
DN15	½"	147	5.79	83	3.27	118	4.65	132	5.20	55	2.17
DN25	1"	147	5.79	83	3.27	130	5.12	132	5.20	55	2.17
DN50	2"	147	5.79	83	3.27	143	5.63	132	5.20	55	2.17
DN80	3"	147	5.79	83	3.27	160	6.30	132	5.20	55	2.17
DN100	4"	147	5.79	83	3.27	169	6.66	132	5.20	55	2.17

		Dimensions M8M						Dimensions M8E					
		f		g		h		f		g		h	
EN	ASME	[mm]	["]	[mm]	["]	[mm]	["]	[mm]	["]	[mm]	["]	[mm]	["]
DN15	½"	63	2.48	60	2.36	58.5	2.30	53.5	2.11	66	2.60	52.5	2.07
DN25	1"	75	2.95	60	2.36	58.5	2.30	65.5	2.58	66	2.60	52.5	2.07
DN50	2"	89	3.51	73	2.88	45.5	1.79	79.5	3.13	79	3.11	39.5	1.56
DN80	3"	105	4.14	73	2.88	45.5	1.79	95.5	3.76	79	3.11	39.5	1.56
DN100	4"	114	4.49	73	2.88	45.5	1.79	104	4.12	79	3.11	39.5	1.56

For overall height see devices with indicator M9

Weights

		H250		with heating			
Nominal size		EN 1092-1		Flange connection		Ermeto connection	
EN	ASME	[kg]	[lbs]	[kg]	[lbs]	[kg]	[lbs]
DN15	½"	3.5	7.7	5.6	12.6	3.9	8.6
DN25	1"	5	11	7.5	16.5	5.8	12.8
DN50	2"	8.2	18.1	11.2	24.7	9.5	21
DN80	3"	12.2	26.9	14.8	32.6	13.1	28.9
DN100	4"	14	30.9	17.4	38.4	15.7	34.6

		H250/C [Ceramic / PTFE]						Screw connection	
Nominal size		EN 1092-1		ASME 150 lbs		ASME 300 lbs		DIN 11864-1	
EN	ASME	[kg]	[lbs]	[kg]	[lbs]	[kg]	[lbs]	[kg]	[lbs]
DN15	½"	3.5	7.7	3.2	7.1	3.5	7.7	2	4.4
DN25	1"	5	11	5.2	11.5	6.8	15	3.5	7.7
DN50	2"	10	22.1	10	22.1	11	24.3	5	11
DN80	3"	13	28.7	13	28.7	15	33.1	7.6	16.8
DN100	4"	15	33.1	16	35.3	17	37.5	10.3	22.7

Process connections

	Standards	Conn. dim.	Pressure rating
Flanges (H250/RR /HC /C)	EN 1092-1	DN15...100	PN16...250
	ASME B16.5	½...4"	150...2500 lbs
	JIS B 2220	15...100	10...20K
Clamp connections (H250/RR /F)	DIN 32676	DN15...100	10...16 bar
	ISO 2852	Size 25...139.7	10...16 bar
Screw connections (H250/RR /HC /F)	DIN 11851	DN15...100	25...40 bar
	SMS 1146	1...4"	6 bar / 88.2 psig
Female thread welded (H250/RR /HC)	ISO 228	G½...G2"	≥ 50 bar / 735 psig
	ASME B1.20.1	½...2" NPT	
Female thread (H250/RR /HC) with insert, FPM gasket and union nut	ISO 228	G½...2"	≤ 50 bar / 735 psig
	ASME B1.20.1	½...2" NPT	
Thread connection aseptic (H250/F)	DIN 11864 - 1	DN15...50	PN40
		DN80...100	PN 16
Flange aseptic (H250/F)	DIN 11864 - 2	DN15...50	PN40
		DN80...DN100	PN 16
Meters (H250/RR /HC) with heating:			
Heating with flange connection	EN 1092-1	DN15	PN40
	ASME B16.5	½"	150 lbs / RF
Heating pipe connection for Ermeto	-	E12	PN40

Higher pressure ratings and other connections on request

Bolts and tightening torques

For flowmeters with PTFE liner or ceramic liner and PTFE raised face, tighten the flange threads with the following torques:

Nominal sizes EN

Nominal size acc. to EN 1092-1	Bolts		Tightening torques	
	Quantity x size		[Nm]	[lb-ft]
DN15 PN40 ①	4 x M 12		9.8	7.1
DN25 PN40 ②	4 x M 12		21	15
DN50 PN40 ②	4x M16		57	41
DN80 PN16 ②	8x M16		47	34
DN100 PN16 ②	8x M16		67	48

① standard connections; other connection on request

② standard connections; other connections on request

Nominal size ASME

Nominal size acc. to ASME B 16.5	Bolts		Tightening torques	
	Quantity x size		[Nm]	[lb-ft]
	150 lbs	300 lbs		
½" 150 lbs / 300 lbs ①	4x ½"	4x ½"	5.2	3.8
1" 150 lbs / 300 lbs ①	4x ½"	4x 5/8"	10	7.2
2" 150 lbs / 300 lbs ①	4x 5/8"	8x 5/8"	41	30
3" 150 lbs / 300 lbs ①	4x 5/8"	8x ¾"	70	51
4" 150 lbs / 300 lbs ①	8x 5/8"	8x ¾"	50	36

① standard connections; other connections on request

2.3 Measuring ranges

H250/RR - Stainless Steel, H250/HC - Hastelloy®

Measuring span 10 : 1; flow values 100%

Float ▶		Water			Air			Max. pressure loss			
		TIV	CIV	DIV	TIV Alu	TIV	DIV	TIV Alu	TIV	CIV	DIV
Nominal size	Cone	[l/h]			[m ³ /h]			[mbar]			
DN15, ½"	K 15.1	18	25	-	0.42	0.7	-	12	21	26	-
	K 15.2	30	40	-	0.7	1	-	12	21	26	-
	K 15.3	55	63	-	1	1.5	-	12	21	26	-
	K 15.4	80	100	-	1.7	2.2	-	12	21	26	-
	K 15.5	120	160	-	2.5	3.6	-	12	21	26	-
	K 15.6	200	250	-	4.2	5.5	-	12	21	26	-
	K 15.7	350	400	700	6.7	10	18 ①	12	21	28	38
	K 15.8	500	630	1000	10	14	28 ①	13	22	32	50
DN25, 1"	K 15.8	-	-	1600 ②	-	-	50 ②	-	-	-	85
	K 25.1	480	630	1000	9.5	14	-	11	24	32	72
	K 25.2	820	1000	1600	15	23	-	11	24	33	74
	K 25.3	1200	1600	2500	22	35	-	11	25	34	75
	K 25.4	1700	2500	4000	37	50	110 ①	12	26	38	78
DN50, 2"	K 25.5	3200	4000	6300	62	95	180 ①	13	30	45	103 ③
	K 55.1	2700	6300	8400	58	80	230 ①	8	13	74	60
	K 55.2	3600	10000	14000	77	110	350 ①	8	13	77	69
DN80, 3"	K 55.3	5100	16000	25000	110	150	700 ①	9	13	84	104
	K 85.1	12000	25000	37000	245	350	1000 ①	8	16	68	95
DN100, 4"	K 85.2	16000	40000	64000	280	400	1800 ①	9	16	89	125
	K105.1	19000	63000	100 000	-	550	2800 ①	-	-	120	220

① P > 0.5 bar

② with TR float

③ 300 mbar with damping (gas measurement)

Reference condition:

Water 20°C

Air 20°C - 1.013bar abs.

Remarks:

- Air measurement - TIV float: heating not possible.
- The indicated pressure losses are valid for water and air at maximum flow rate.
- Other flow ranges on request.
- Conversion of other media or operating data is performed using the calculation method in accordance with VDI /VDE Directive 3513.

H250/RR - Stainless Steel, H250/HC - Hastelloy®

Measuring span 10 : 1; flow values 100%

		Water			Air			Max. pressure loss			
Float ▶		TIV	CIV	DIV	TIV Alu	TIV	DIV	TIV Alu	TIV	CIV	DIV
Nominal size	Cone	[gph]			[scfm]			[psig]			
DN15, ½"	K 15.1	4.76	6.60	-	0.26	0.43	-	0.18	0.31	0.38	-
	K 15.2	7.93	10.6	-	0.43	0.62	-	0.18	0.31	0.38	-
	K 15.3	14.5	16.6	-	0.62	0.93	-	0.18	0.31	0.38	-
	K 15.4	21.1	26.4	-	1.05	1.36	-	0.18	0.31	0.38	-
	K 15.5	31.7	42.3	-	1.55	2.23	-	0.18	0.31	0.38	-
	K 15.6	52.8	66.0	-	2.60	3.41	-	0.18	0.31	0.38	-
	K 15.7	92.5	106	185	4.15	6.20	11.2 ①	0.18	0.31	0.41	0.56
	K 15.8	132	166	264	6.20	8.68	17.4 ①	0.19	0.32	0.47	0.74
DN25, 1"	K 15.8	-	-	423 ②	-	-	31.0 ②	-	-	-	1.25
	K 25.1	127	166	264	5.89	8.68	-	0.16	0.35	0.47	1.06
	K 25.2	217	264	423	9.30	14.3	-	0.16	0.35	0.49	1.09
	K 25.3	317	423	660	13.6	21.7	-	0.16	0.37	0.50	1.10
	K 25.4	449	660	1057	22.9	31.0	68.2 ①	0.18	0.38	0.56	1.15
DN50, 2"	K 25.5	845	1057	1664	38.4	58.9	111 ①	0.19	0.44	0.66	1.51 ③
	K 55.1	713	1664	2219	36.0	49.6	143 ①	0.12	0.19	1.09	0.88
	K 55.2	951	2642	3698	47.7	68.2	217 ①	0.12	0.19	1.13	1.01
DN80, 3"	K 55.3	1347	4227	6604	68.2	93.0	434 ①	0.13	0.19	1.23	1.53
	K 85.1	3170	6604	9774	152	217	620 ①	0.12	0.24	1.00	1.40
DN100, 4"	K 85.2	4227	10567	16907	174	248	1116 ①	0.13	0.24	1.31	1.84
	K105.1	5019	16643	26418	-	341	1736 ①	-	-	1.76	3.23

① P > 7.4 psig

② with TR float

③ 4.4 psig with damping [gas measurement]

Reference condition:

Water 68°F

Air 68°F - 14.7 psi

Remarks:

- Air measurement - TIV float: heating not possible.
- The indicated pressure losses are valid for water and air at maximum flow rate.
- Other flow ranges on request.
- Conversion of other media or operating data is performed using the calculation method in accordance with VDI /VDE Directive 3513.

H250/C - Ceramic/PTFE

Measuring span 10 : 1; flow values 100%

		Flow rate			Max. pressure loss		
		Water		Air	Water		Air
Liner / Float ▶		PTFE	Ceramic	Ceramic	PTFE	Ceramic	Ceramic
Nominal size	Cone	[l/h]		[m ³ /h]	[mbar]		
DN15, ½"	E 17.2	25	30	-	65	62	62
	E 17.3	40	50	1.8	66	64	64
	E 17.4	63	70	2.4	66	66	66
	E 17.5	100	130	4	68	68	68
	E 17.6	160	200	6.5	72	70	70
	E 17.7	250	250	9	86	72	72
	E 17.8	400	-	-	111	-	-
DN25, 1"	E 27.1	630	500	18	70	55	55
	E 27.2	1000	700	22	80	60	60
	E 27.3	1600	1100	30	108	70	70
	E 27.4	2500	1600	50	158	82	82
	E 27.5	4000 ①	2500	75	290	100	100
DN50, 2"	E 57.1	4000	4500	140	81	70	70
	E 57.2	6300	6300	200	110	80	80
	E 57.3	10000	11000	350	170	110	110
	E 57.4	16000 ①	-	-	284	-	-
DN80, 3"	E 87.1	16000	16000	-	81	70	-
	E 87.2	25000	25000	-	95	85	-
	E 87.3	40000 ①	-	-	243	-	-
DN100, 4"	E 107.1	40000	-	-	100	-	-
	E 107.2	60000 ①	-	-	225	-	-

① special float

Reference condition:

Water 20°C

Air 20°C - 1.013bar abs.

Remarks:

- The indicated pressure losses are valid for water and air at maximum flow rate.
- Other flow ranges on request.
- Conversion of other media or operating data is performed using the calculation method in accordance with VDI /VDE Directive 3513.

H250/C - Ceramic/PTFE

Measuring span 10 : 1; flow values 100%

		Flow rate			Max. pressure loss		
		Water		Air	Water		Air
Liner / Float ▶		PTFE	Ceramic	Ceramic	PTFE	Ceramic	Ceramic
Nominal size	Cone	[gph]		[scfm]	[psig]		
DN15, ½"	E 17.2	6.60	7.93	-	0.96	0.91	0.91
	E 17.3	10.6	13.2	1.12	0.97	0.94	0.94
	E 17.4	16.6	18.5	1.49	0.97	0.97	0.97
	E 17.5	26.4	34.3	2.48	1.00	1.00	1.00
	E 17.6	42.3	52.8	4.03	1.06	1.03	1.03
	E 17.7	66.0	66.0	5.58	1.26	1.06	1.06
	E 17.8	106	-	-	1.63	-	-
	DN25, 1"	E 27.1	166	132	11.2	1.03	0.81
E 27.2		264	185	13.6	1.18	0.88	0.88
E 27.3		423	291	18.6	1.59	1.03	1.03
E 27.4		660	423	31.0	2.32	1.21	1.21
E 27.5		1056 ①	660	46.5	4.26	1.47	1.47
DN50, 2"	E 57.1	1057	1189	86.8	1.19	1.03	1.03
	E 57.2	1664	1664	124	1.62	1.18	1.18
	E 57.3	2642	2906	217	2.50	1.62	1.62
	E 57.4	4226 ①	-	-	4.17	-	-
DN80, 3"	E 87.1	4227	4227	-	1.19	1.03	-
	E 87.2	6604	6604	-	1.40	1.25	-
	E 87.3	10567 ①	-	-	3.57	-	-
DN100, 4"	E 107.1	10567	-	-	1.47	-	-
	E 107.2	15850 ①	-	-	3.31	-	-

① special float

Reference condition:

Water 68°F

Air 68°F - 14.7 psi

Remarks:

- The indicated pressure losses are valid for water and air at maximum flow rate.
- Other flow ranges on request.
- Conversion of other media or operating data is performed using the calculation method in accordance with VDI /VDE Directive 3513.

H250H - Horizontal installation position

Measuring span 10 : 1; flow values 100%

EN	ASME	Cone	Flow rate Water [l/h]	Flow rate Air [Nm ³ /h]	Pressure loss [mbar]
DN15	½	K 15.1	70	1.8	195
		K 15.2	120	3	204
		K 15.3	180	4.5	195
		K 15.4	280	7.5	225
		K 15.5	450	12	250
		K 15.6	700	18	325
		K 15.7	1200	30	590
		K 15.8	1600	40	950
DN25	1"	K 25.1	1300	35	122
		K 25.2	2000	50	105
		K 25.3	3000	80	116
		K 25.4	5000	130	145
		K 25.5	8500	220	217
		K 25.5	10000	260	336
DN50	2"	K 55.1	10000	260	240
		K 55.2	16000	420	230
		K 55.3	22000	580	220
		K 55.3	34000	900	420
DN80	3"	K 85.1	25000	650	130
		K 85.2	35000	950	130
		K 85.2	60000	1600	290
DN100	4"	K 105.1	80000	2200	250
		K 105.1	120000	3200	340

Reference condition:

Water 20°C

Air 20°C - 1.013bar abs.

Remarks:

- The indicated pressure losses are valid for water and air at maximum flow rate.
- Other flow ranges on request.
- Conversion to other media or operating data in accordance with VDE /VDI Directive 3513

H250H - Horizontal installation position

Measuring span 10 : 1; flow values 100%

EN	ASME	Cone	Flow rate Water [gph]	Flow rate Air [scfm]	Pressure loss [psig]
DN15	1/2"	K 15.1	18.5	1.12	2.87
		K 15.2	31.7	1.86	3.00
		K 15.3	47.6	2.79	2.87
		K 15.4	74.0	4.65	3.31
		K 15.5	119	7.44	3.68
		K 15.6	185	11.2	4.78
		K 15.7	317	18.6	8.68
		K 15.8	423	24.8	14.0
DN25	1"	K 15.8	634	37.2	23.5
		K 25.1	343	21.7	1.79
		K 25.2	528	31.0	1.54
		K 25.3	793	49.6	1.71
		K 25.4	1321	80.6	2.13
		K 25.5	2245	136	3.19
		K 25.5	2642	161	4.94
DN50	2"	K 55.1	2642	161	3.53
		K 55.2	4227	260	3.38
		K 55.3	5812	360	3.23
		K 55.3	8982	558	6.17
DN80	3"	K 85.1	6604	403	1.91
		K 85.2	9246	589	1.91
		K 85.2	15851	992	4.26
DN100	4"	K 105.1	21134	1364	3.68
		K 105.1	31701	1984	5.00

Reference condition:

Water 68°F

Air 68°F - 14.7 psi

Remarks:

- The indicated pressure losses are valid for water and air at maximum flow rate.
- Other flow ranges on request.
- Conversion to other media or operating data in accordance with VDE /VDI Directive 3513

H250U - Vertical installation position

Flow direction from top to bottom

Measuring span 10 : 1; flow values 100%

EN	ASME	Cone	Flow rate Water [l/h]	Flow rate Air [Nm ³ /h]	Pressure loss [mbar]
DN15	½"	K 15.1	65	1.6	175
		K 15.2	110	2.5	178
		K 15.3	170	4	180
		K 15.4	260	6	200
		K 15.5	420	10	220
		K 15.6	650	16	290
		K 15.7	1100	28	520
		K 15.8	1500	40	840
DN25	1"	K 25.1	1150	30	97
		K 25.2	1800	45	85
		K 25.3	2700	70	92
		K 25.4	4500	120	115
		K 25.5	7600	200	172
DN50	2"	K 55.1	9000	240	220
		K 55.2	15000	400	230
		K 55.3	21000	550	240

Reference condition:

Water 20°C

Air 20°C - 1.013bar abs.

Remarks:

- The indicated pressure losses are valid for water and air at maximum flow rate.
- Other flow ranges on request.
- Conversion to other media or operating data in accordance with VDE /VDI Directive 3513

H250U - Vertical installation position

Flow direction from top to bottom

Measuring span 10 : 1; flow values 100%

EN	ASME	Cone	Flow rate Water [gph]	Flow rate Air [scfm]	Pressure loss [psig]
DN15	½"	K 15.1	17.2	0.99	2.57
		K 15.2	29.1	1.55	2.62
		K 15.3	44.9	2.48	2.65
		K 15.4	68.7	3.72	2.94
		K 15.5	111	6.20	3.23
		K 15.6	172	9.92	4.26
		K 15.7	291	17.4	7.64
		K 15.8	396	24.8	12.3
DN25	1"	K 25.1	304	18.6	1.42
		K 25.2	476	27.9	1.25
		K 25.3	713	43.4	1.35
		K 25.4	1189	74.4	1.69
		K 25.5	2008	124	2.53
DN50	2"	K 55.1	2378	149	3.23
		K 55.2	3963	248	3.38
		K 55.3	5548	341	3.53

Reference condition:

Water 68°F

Air 68°F - 14.7 psi

Remarks:

- The indicated pressure losses are valid for water and air at maximum flow rate.
- Other flow ranges on request.
- Conversion to other media or operating data in accordance with VDE /VDI Directive 3513

3.1 Intended use

The variable area flowmeters are suitable for measuring gases, vapours and liquids.

The devices are particularly suitable for the measurement of:

- Liquids
- Hydrocarbons
- Water
- Chemicals with low corrosiveness
- Saturated steam
- Superheated steam
- Food and luxury food
- Industrial gases

For devices used in hazardous areas, additional safety notes apply; please refer to the Ex documentation.

The operator himself bears the sole responsibility for the intended use of the device regarding the suitability and the corrosion resistance of the used materials against the measured fluid. The manufacturer is not liable for any damage resulting from improper use or use for other than the intended purpose.

Do not use any abrasive or highly viscous media.

3.2 Installation conditions

When installing the device in the piping, the following points must be observed:

- *The variable area flowmeter must be installed vertically (measuring principle). Flow direction from bottom to top. For installation recommendations please refer also to VDI/VDE 3513 Sheet 3.
H250Hs are installed horizontally and H250U devices are installed vertically with the flow direction from top to bottom.*
- *A straight unimpeded inlet run of $\geq 5x$ DN upstream of the device and a straight outlet run of $\geq 3x$ DN downstream of the device are recommended.*
- *Screws, bolts and gaskets are to be provided by the customer and must be selected in accordance with the pressure rating of the connection or the operating pressure.*
- *The inside diameter of the flange deviates from the standard dimensions. Flange seal standard DIN 2690 can be applied without any limitation.*
- *Align the gaskets. Tighten the nuts with the tightening torques of the appropriate pressure rating.
For devices with PTFE liner or ceramic liner and PTFE raised faces, see chapter "Tightening torques".*
- *Control devices are to be positioned downstream of the measuring device.*
- *Shutoff devices are preferably to be positioned upstream of the measuring device.*
- *Before connecting, blow or flush out the pipes leading to the device.*
- *Pipes for gas flow need to be dried before the device is installed.*
- *Use connectors suitable for the particular device version.*
- *Align the pipes axially with the connections on the measuring device so they are free of stresses.*
- *If necessary, the piping has to be supported to prevent vibrations being transmitted to the measuring device.*
- *Do not lay signal cables directly next to cables for the power supply.*

Take special note of the installation position for the H250H with horizontal flow direction:

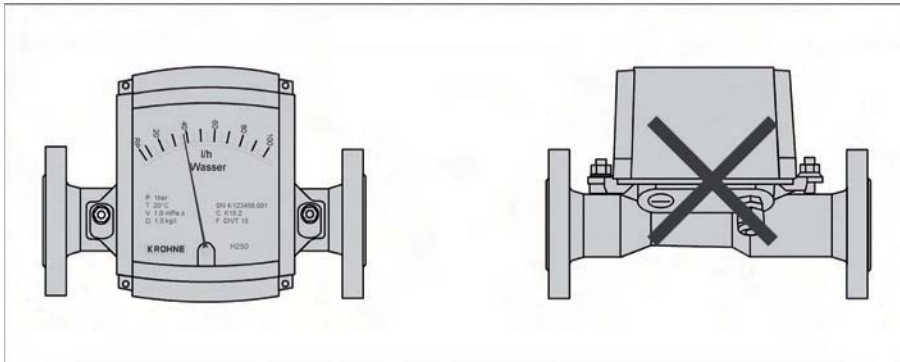

In order to comply with thermal parameters and measuring accuracy, H250H flowmeters for horizontal installation are to be installed in the pipeline so that the display is located on the side of the measuring tube. The maximum medium and ambient temperatures indicated as well as the measuring accuracy are based on lateral installation of the display.

3.2.1 Magnetic filters

The use of magnetic filters is recommended when the medium contains particles which can be influenced magnetically.

The magnetic filter is to be installed in the flow direction upstream of the flowmeter.

Bar magnets are positioned helically in the filter to provide optimal efficiency at low pressure loss.

All of the magnets are coated individually with PTFE to protect against corrosion.

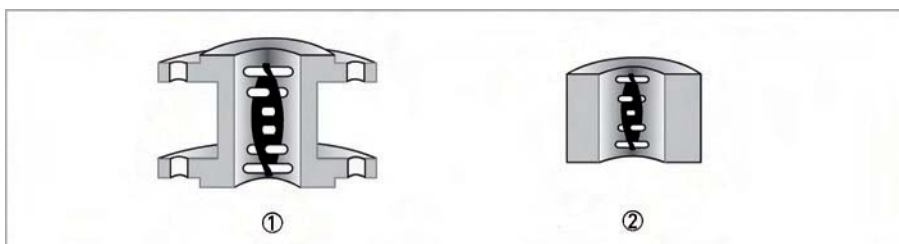

Figure 3-1: Magnetic filters

- ① Type F - fitting part with flange - overall length 100 mm
- ② Type FS - fitting part without flange - overall length 50 mm

Material: 1.4571

3.2.2 Heat insulation

The indicator housing may not be heat-insulated.

The heat insulation ③ may only reach as far as the housing fastening ④.

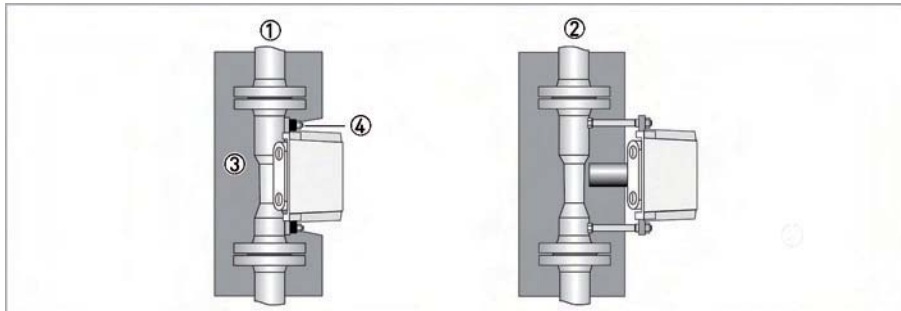

Figure 3-2: H250 heat insulation

- ① Standard indicator M9
- ② Indicator with HT extension

This applies in the same manner to indicators M8 and M10.

The heat insulation ① may only reach to the rear of the housing ②. The area of the cable entries ③ must be freely accessible.

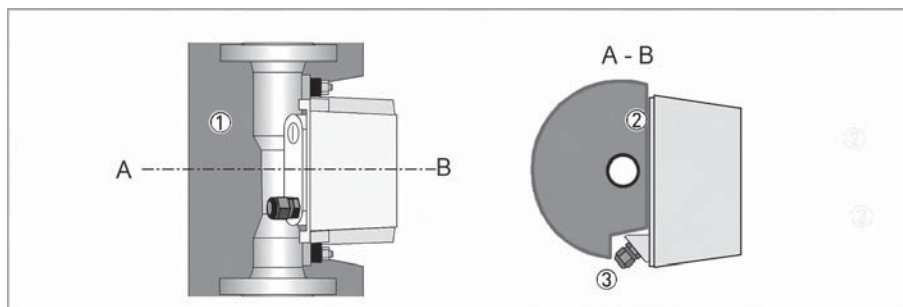

Figure 3-3: Insulation - cross section

3.2.3 Float damping

Float damping is characterised by high standstill times and self-centering. The damping sleeve is made of high performance ceramic or PEEK, depending on the medium and the application. Float damping can also be retrofitted for the user (see Service).

Use of damping

- Generally when CIV and DIV floats are used for gas measurement.
- For TIV floats (H250/RR and H250/HC only) with an operating primary pressure:

Nominal size acc. to		Operating primary pressure	
EN 1092-1	ASME B16.5	[bar]	[psi]
DN15	½"	≤0.3	≤4.4
DN25	1"	≤0.3	≤4.4
DN50	2"	≤0.2	≤2.9
DN80	3"	≤0.2	≤2.9
DN100	4"	≤0.2	≤2.9

3.2.4 Pointer damping

The pointer system with its magnetic system basically contains pointer damping. An additional eddy current brake is advantageous for fluctuating or pulsing flows. The eddy current brake magnets surround the pointer vane ① without touching it, damping its movement. The result is a pointer position that is considerably calmer, and no distortion of the measured value. A clamp screw holds it in place securely. The eddy current brake can be retrofitted without having to recalibrate and while in operation (see Service).

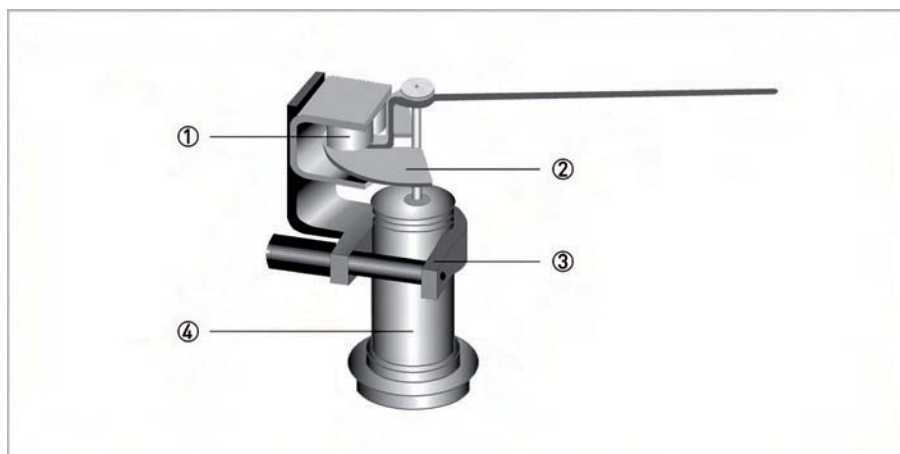

- ① Eddy current brake
- ② Pointer vane
- ③ Bracket
- ④ Pointer cylinder

4.1 Electrical connection indicator M8

4.1.1 Indicator M8M - limit switches

The limit switches can be set over the entire measuring range using the maximum pointer ①. The set limit values are displayed on the scale. The pointers are set to the desired limit values using a slip coupling along the scale.

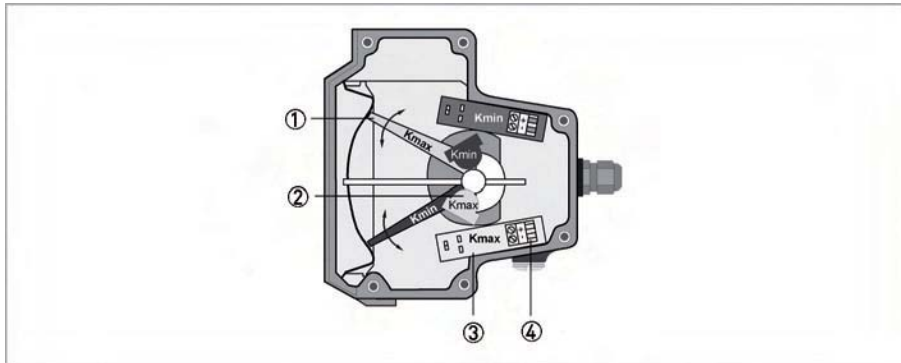

Figure 4-1: Limit switch settings M8MG

- ① Maximum pointer, switching point indicator
- ② Limit switch
- ③ Connection board
- ④ Connection terminal

4.1.2 Indicator M8E - current output

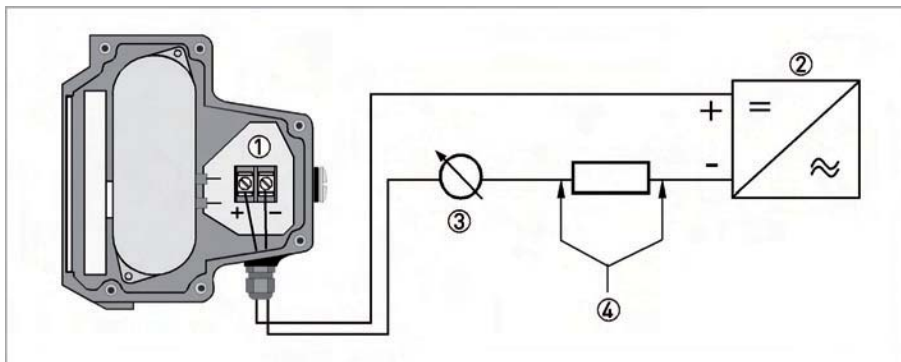

Figure 4-2: Electrical connection M8EG

- ① Terminal connection
- ② Power supply 14.8...30 VDC
- ③ Measuring signal 4...20 mA
- ④ External load, HART® communication

Power supply M8 with electrical isolation

The circuitry for connection to other devices such as digital evaluator units or process control equipment must be designed with especial care. In some circumstances internal connections in these devices (e.g. GND with PE, ground loops) may lead to impermissible voltage potentials, which can compromise the function of the device itself or a connected device. In such cases a protected extra-low voltage (PELV) is recommended.

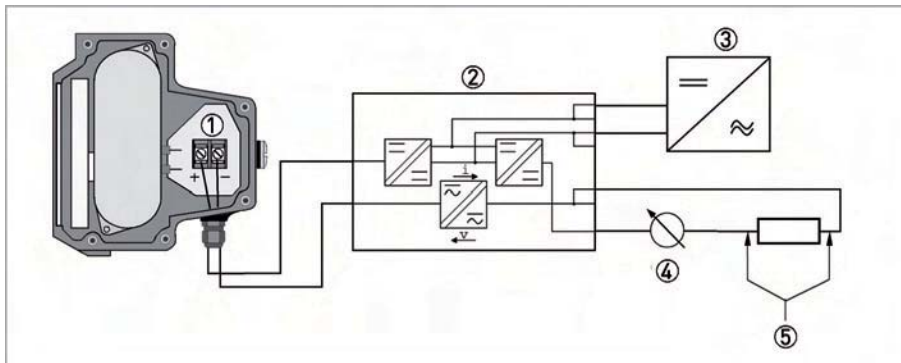

Figure 4-3: Electrical connection M8EG with electrical isolation

- ① Terminal connection
- ② Converter supply isolator with electrical isolation
- ③ Power supply (see supply isolator information)
- ④ Measuring signal 4...20 mA
- ⑤ External load, HART® communication

Power supply

The supply voltage has to be between 14.8 VDC and 30 VDC. This is based on the total resistance of the measuring loop. To determine this, add up the resistances of each component in the measuring loop (not including the device).

The required supply voltage can be calculated using the formula below:

$$U_{\text{ext.}} = R_L \cdot 22 \text{ mA} + 14.8 \text{ V}$$

where

$U_{\text{ext.}}$ = the minimum supply voltage and

R_L = the total measuring loop resistance is.

The power supply has to be able to supply a minimum of 22 mA.

HART® communication

When HART® communication is carried out with the M8E display, the analogue measured data transmission (4...20 mA) is not impaired in any way.

Exception for multidrop mode. In multidrop mode, a maximum of 15 devices with HART® function can be operated in parallel, whereby their current outputs are switched inactive (I approx. 4 mA per device).

Load for HART® communication

For HART® communication a load of at least 230 ohm is required.

The maximum load resistance is calculated as follows:

$$R_L = \frac{U_{ext.} - 14,8V}{22 mA}$$

Use a twisted two-core cable to prevent electrical interference from impeding the DC output signal.

In some cases a shielded cable may be necessary. The cable shield may only be earthed (grounded) at one place (on the power supply unit).

Configuration

The M8E electronic indicator can be configured via HART® communication. DD (Device Descriptions) for AMS 6.x and PDM 5.2 as well as a DTM (Device Type Manager) are available for configuration. They can be downloaded free of charge from our website.

The current flow rate can be transmitted using the integrated HART® communication. A flow counter can be configured. Two limit values can be set and monitored. The limit values are assigned either to flow values or to the counter overflow. The limit values are not depicted on the display.

4.2 Electrical connection indicator M9

4.2.1 Indicator M9 - limit switches

The M9 indicator can be equipped with a maximum of two electronic limit switches. The limit switch functions as a slot sensor which is operated inductively through the semicircular metal vane belonging to the measuring pointer. The switching points are set using the contact pointers. The position of the contact pointer is indicated on the scale. The position of the contact pointer is indicated on the scale.

Limit switch module

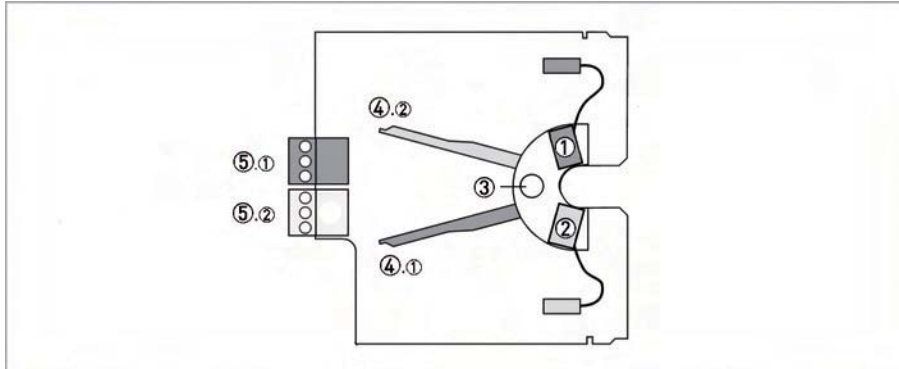

- ① Min. contact
- ② Max. contact
- ③ Locking screw
- ④ Maximum pointer
- ⑤ Connection terminal

The connecting terminals have a pluggable design and can be removed in order to connect the cables. The built-in limit switch types are shown on the indicator.

Electrical connection of the limit switches

Contact	MIN			MAX		
	1	2	3	4	5	6
Terminal no.						
Connection 2-wire NAMUR	-	+		-	+	
Connection 3-wire	+	DC	-	+	DC	-

Limit switch connection terminals

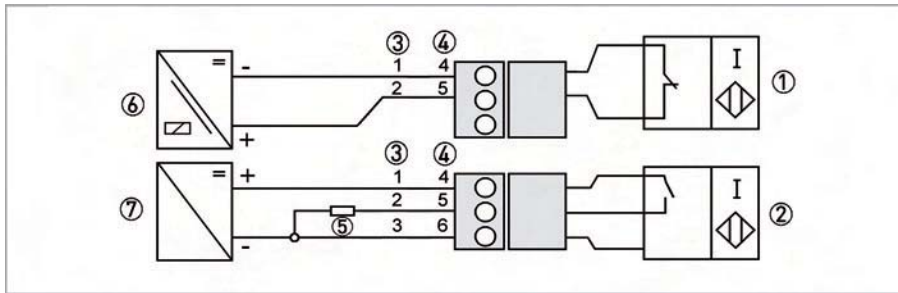

- ① 2-wire limit switch NAMUR
- ② 3-wire limit switch
- ③ Terminal connection min contact
- ④ Terminal connection max contact
- ⑤ 3-wire load
- ⑥ NAMUR isolated switching amplifier
- ⑦ 3-wire power supply

Limit setting

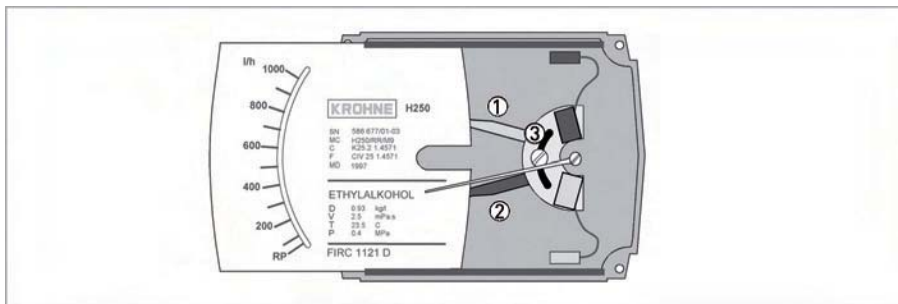

Figure 4-4: Limit switch settings

- ① Contact pointer MAX
- ② Contact pointer MIN
- ③ Locking screw

Setting is carried out directly via contact pointers ① and ②:

- Slide the scale away
- Loosen the locking screw ③ slightly
- Slide the scale back to the latching point
- Set contact pointers ① and ② to the desired switching point

After setting has been carried out: Fix the contact pointers with the locking screw ③.

Switch contact definition

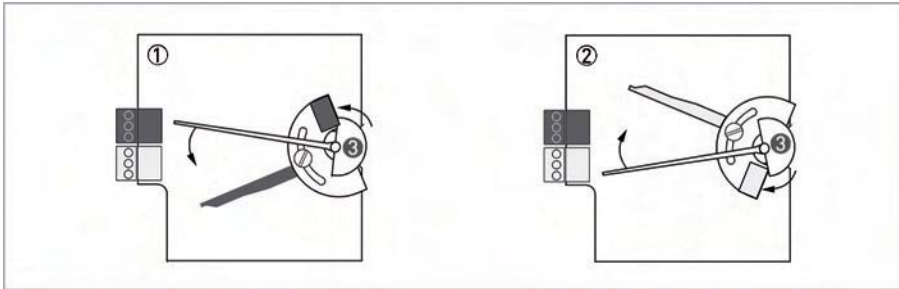

- ① MIN contact
- ② MAX contact
- ③ Pointer vane with switching vane

If the pointer vane enters the slot, an alarm is triggered. If the pointer vane lies outside the slot sensor, a wire break also causes the alarm to be triggered.

The 3-wire limit switch does not have any wire break detection.

Definition MinMin - MaxMax

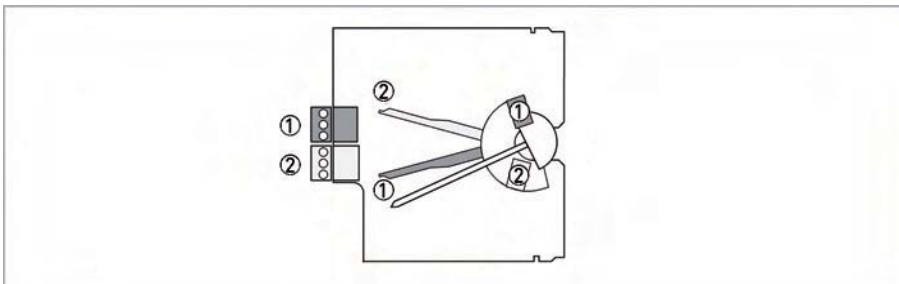

- ① MIN 2 contact or MAX 1 contact
- ② MIN 1 contact or MAX 2 contact

Current consumption in the position shown:

Contact	Type	Current
MIN 1	NAMUR	≤ 1 mA
MIN 2	NAMUR	≤ 1 mA
MAX 1	NAMUR	≥ 3 mA
MAX 2	NAMUR	≥ 3 mA

4.2.2 Indicator M9 - current output ESK2A

The connecting terminals of the ESK2A have a pluggable design and can be removed in order to connect the cables.

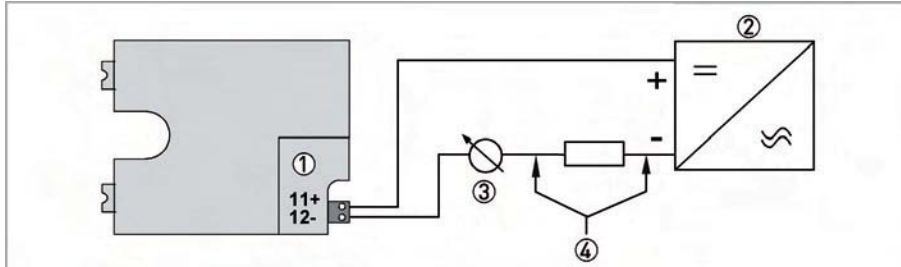

- ① ESK2A current output
- ② Power supply 12...30VDC
- ③ Measuring signal 4...20 mA
- ④ External load, HART® communication

Power supply M9 with electrical isolation

The circuitry for connection to other devices such as digital evaluator units or process control equipment must be designed with especial care. In some circumstances internal connections in these devices (e.g. GND with PE, ground loops) may lead to impermissible voltage potentials, which can compromise the function of the device itself or a connected device. In such cases a protected extra-low voltage (PELV) is recommended.

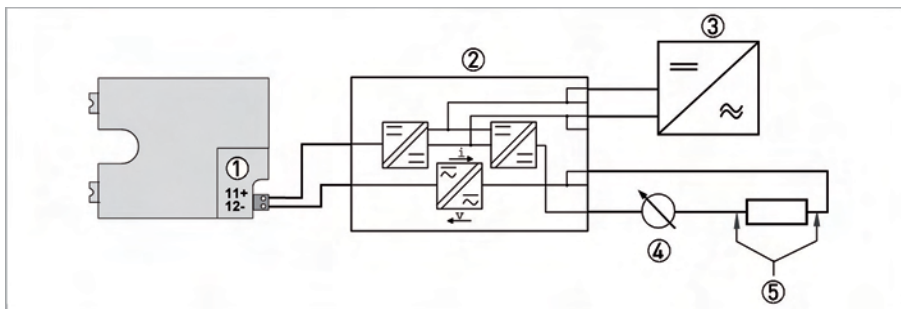

- ① Terminal connection
- ② Converter supply isolator with electrical isolation
- ③ Power supply (see supply isolator information)
- ④ Measuring signal 4...20 mA
- ⑤ External load, HART® communication

Power supply

The supply voltage has to be between 12 VDC and 30 VDC. This is based on the total resistance of the measuring loop. To determine this, add up the resistances of each component in the measuring loop (not including the device).

The required supply voltage can be calculated using the formula below:

$$U_{\text{ext.}} = R_L \cdot 22 \text{ mA} + 12 \text{ V}$$

where

$U_{\text{ext.}}$ = the minimum supply voltage and

R_L = the total measuring loop resistance is.

The power supply has to be able to supply a minimum of 22 mA.

HART® communication

When HART® communication is carried out with the ESK, the analogue measured data transmission (4...20 mA) is not impaired in any way.

Exception for multidrop mode. In multidrop mode, a maximum of 15 devices with HART® function can be operated in parallel, whereby their current outputs are switched inactive (I approx. 4 mA per device).

Load for HART® communication

For HART® communication a load of at least 230 ohm is required.

The maximum load resistance is calculated as follows:

$$R_L = \frac{U_{ext.} - 12V}{22 mA}$$

Use a twisted two-core cable to prevent electrical interference from impeding the DC output signal.

In some cases a shielded cable may be necessary. The cable shield may only be earthed (grounded) at one place (on the power supply unit).

Configuration

The ESK can be configured via HART® communication. DD (Device Descriptions) for AMS 6.x and PDM 5.2 as well as a DTM (Device Type Manager) are available for configuration. They can be downloaded free of charge from our website.

The current flow rate can be transmitted using the integrated HART® communication. A flow counter can be configured. Two limit values can be monitored. The limit values are assigned either to flow values or to the counter overflow.

Self monitoring - Diagnostics

During both start-up and operation, a wide variety of diagnostic functions are performed cyclically in the ESK2A, in order to guarantee function reliability. When an error is detected, a failure signal (high) is activated (current > 21 mA) via the analogue output. In addition, more detailed information can be requested via HART® (CMD#48). The failure signal is not activated for information and warnings.

Diagnostic functions (Monitoring):

- Plausibility of FRAM data
- Plausibility of ROM data
- Working range of internal reference voltages
- Signal detection of the measuring range of the internal sensors
- Temperature compensation of the internal sensors
- Calibration corresponding the application
- Plausibility of counting value
- Plausibility of physical unit, system and selected unit

4.2.3 Indicator M9 - Profibus PA (ESK3-PA)

Bus cable

Shielding and grounding

The statements of the FISCO model only apply if the bus cable used meets the required specifications. For specifications, see the chapter "Technical data" ESK3-PA.

In order to ensure optimum electromagnetic compatibility of systems it is important that the system components, and in particular the bus cables, are shielded. These shields must have as few gaps as possible.

Connection

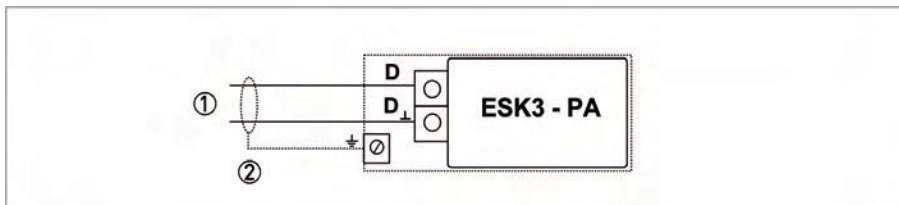

Figure 4-5: ESK3-PA connection

- ① Signal connection
- ② Shielding and grounding

Polarity reversal has no effect on the function. The cable shield should be connected with minimum length to the functional ground FE.

4.2.4 Indicator M9 - totalizer (ESK-Z)

The totalizer only works in conjunction with the ESK2A current output. A 6-digit display shows the totalised flow value. It can be changed over to the instantaneous flow value in 0...100%.

A data backup is carried out automatically in the event of a power failure.

The counter is factory-set to the measuring range of the indicator. The total value can be read directly.

Supply 11/12 and measured signals S+ and S- are not electrically isolated.

If the measured signal is not needed externally, a short-circuit jumper has to be connected to terminals S+ and S-.

Pulse outputs P+ and P- are electrically isolated. A pulse is generated for each counter advance. If the pulse output is not required, its terminals can remain unused.

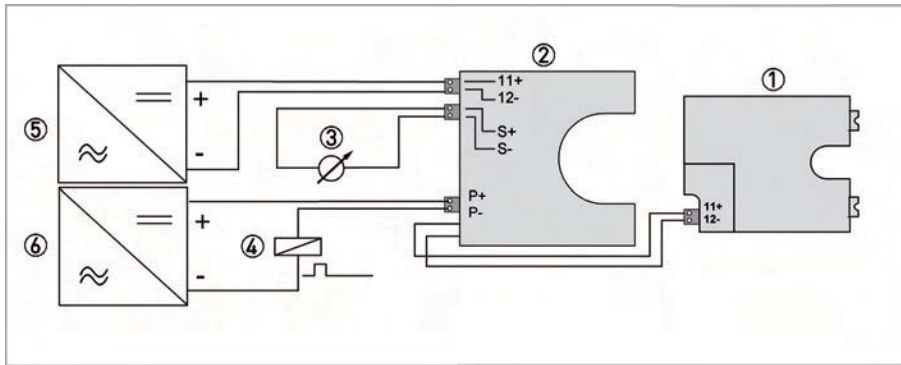

Figure 4-6: Counter connection

- ① ESK - measurement signal 4...20 mA
- ② Counter module
- ③ Transfer of the measurement signal or short-circuit jumper
- ④ Pulse output load
- ⑤ Counter power supply
- ⑥ Pulse output power supply

A functional extra-low voltage with protective electrical isolation (PELV) in accordance with VDE 0100 Part 410 is required as a power supply. All the instruments (recorder, display, etc.) connected to measuring circuits S+ and S- are connected in series. If this measuring circuit is not needed, then a short-circuit jumper ③ required.

Settings - display modes

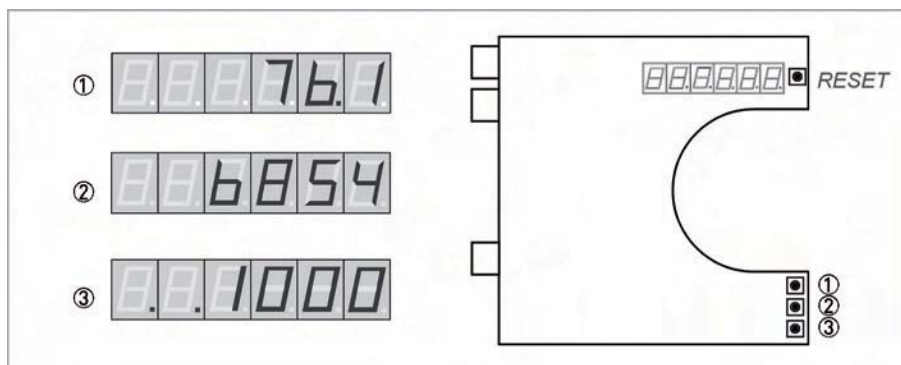

Figure 4-7: Counter display modes

- ① Flow rate as % display
- ② Flow totalizer display
- ③ Conversion factor display

The RESET button deletes only the current total value.

Settings by pressing a button at the moment of switch-on

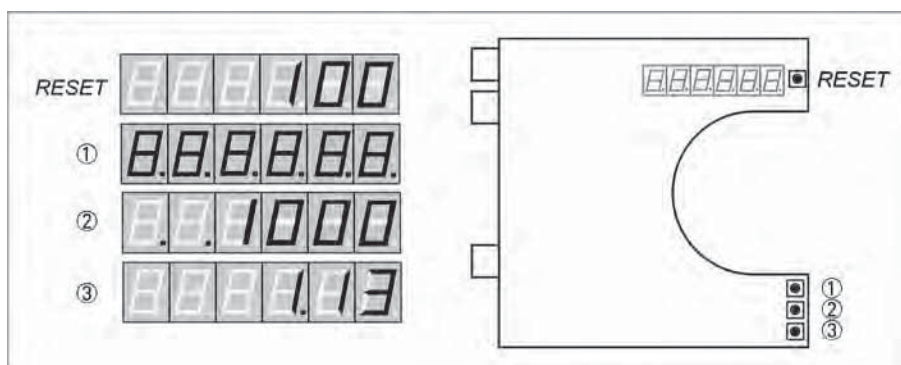

Figure 4-8: Settings of the counter at the moment of switch-on

- RESET button - mA calibration
- Button ① - Display test
- Button ② - Changing the conversion factor
- Button ③ - Software hardware version (information)

Conversion factor

The conversion factor is always 10% of the full-scale range.

If the measuring range is not known, the conversion factor is factory-set to 1000.

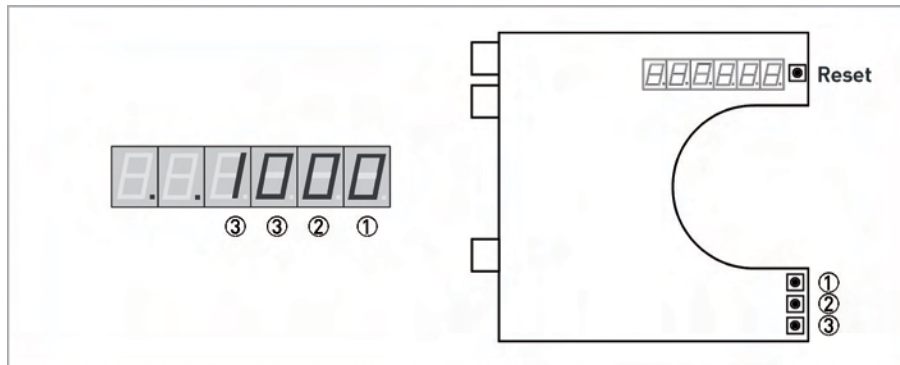

Figure 4-9: Changing the conversion factor

- ① Units position
- ② Tens position
- ③ Hundreds and 1000s position

Exit the setting by pressing the RESET button

The largest factor that can be set is 1099.

Factors with decimal values are not possible.

Counter overflow



Figure 4-10: Depiction of counter overflow

A counter overflow is signaled by all the decimal points lighting up.

Reset by pressing the RESET button.

Current input calibration

During the switching-on process keep the RESET button pressed until three decimal points light up.

- Set 4.00 mA
- Keep button ① pressed until the number 0 is displayed
- Set 20.00 mA
- Keep button ③ pressed until the number 100 is displayed
- Exit calibration by pressing button ②

4.3 Electrical connection indicator M10

4.3.1 Indicator M10

The display can be removed after the housing lid has been unscrewed. The connection terminals have a spring locking system.

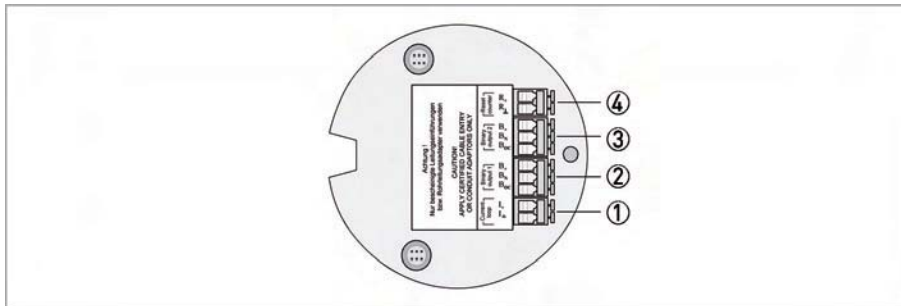

Figure 4-11: Indicator M10 terminal connection

- ① Power supply - analog output
- ② Switching output B1
- ③ Switching output B2 or pulse output
- ④ Reset input R

4.3.2 Power supply - current output

The electrical connection is reverse-polarity protected.

Terminal connection I

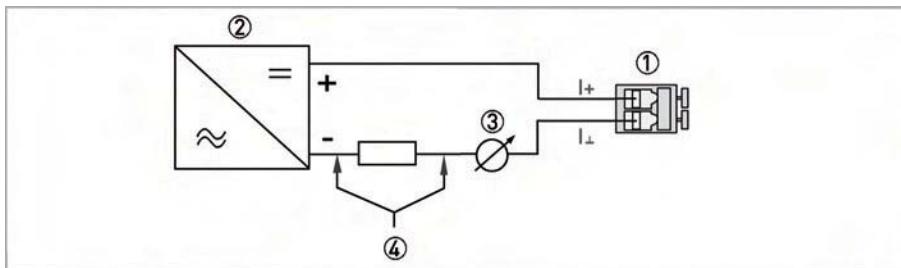

- ① Terminal connection
- ② Power supply 16...32 VDC
- ③ Measuring signal 4...20 mA
- ④ External load, HART® communication

Power supply M10 with electrical isolation

The circuitry to other devices must be designed with special care. In some circumstances, internal connections in these devices (e.g. GND with PE, ground loops) may lead to impermissible voltage potentials, which can compromise the function of the device itself or a connected device. In such cases a protected extra-low voltage (PELV) is recommended.

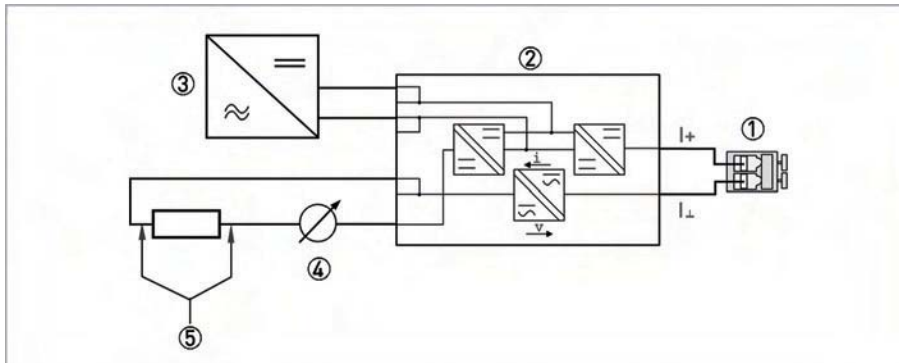

- ① Terminal connection
- ② Converter supply isolator with electrical isolation
- ③ Power supply (see supply isolator information)
- ④ Measuring signal 4...20 mA
- ⑤ External load, HART® communication

Power supply

The supply voltage has to be between 16 VDC and 32 VDC. This is based on the total resistance of the measuring loop. To determine this, add up the resistances of each component in the measuring loop (not including the device).

The required supply voltage can be calculated using the formula below:

$$U_{\text{ext.}} = R_L \cdot 22 \text{ mA} + 16 \text{ V}$$

where

$U_{\text{ext.}}$ = the minimum supply voltage and

R_L = the total measuring loop resistance is.

The power supply has to be able to supply a minimum of 22 mA.

HART[®] communication

When HART[®] communication is carried out with the M10, this will not in any way impair analogue measured data transmission (4...20 mA).

Exception for multidrop operation. In multidrop operation, a maximum of 15 devices with HART[®] function can be operated in parallel, for which the current outputs are switched to inactive.

Load for HART[®] communication

For HART[®] communication a load of at least 230 ohm is required.

The maximum load resistance is calculated as follows:

$$R_L = \frac{U_{ext.} - 16V}{22 mA}$$

Use a twisted two-core cable to prevent electrical interference from impeding the DC output signal.

In some cases a shielded cable may be necessary. The cable shield may only be earthed (grounded) at one place (on the power supply unit).

Configuration

The M10 electronic indicator can be configured via HART[®] communication. DD (Device Descriptions) for AMS 6.x and PDM 5.2 as well as a DTM (Device Type Manager) are available for configuration. They can be downloaded free of charge from our website.

The current flow rate can be transmitted using the integrated HART[®] communication. The flow counter can be configured. Two limit values can be monitored. The limit values are assigned either to flow values or to the counter.

4.3.3 Switching outputs B1 and B2

The switching outputs are electrically isolated from each other and from the current output.

The switching outputs can only be operating if the power supply is applied to terminals I+ and I-.

Switching outputs B1 and B2 can be electrically connected in two ways:

- NAMUR switching output - R_i approx. 1 kOhm
- OC - (open collector) low-resistance switching output with PNP technology

M10 switching outputs

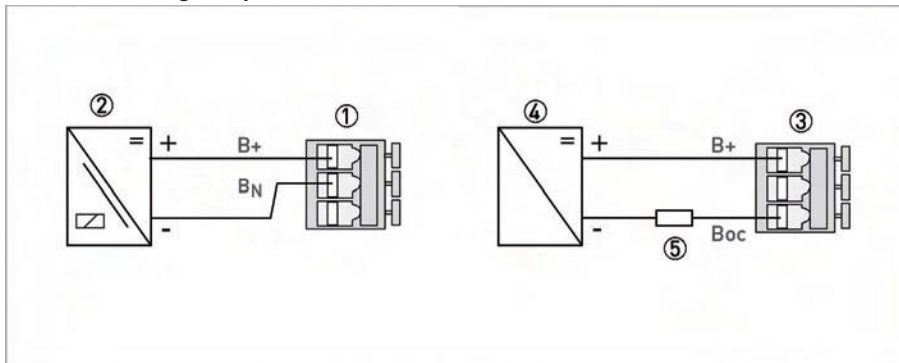

- ① NAMUR terminal connection
- ② Isolated switching amplifier
- ③ PNP technology terminal connection
- ④ Power supply U_{ext} .
- ⑤ Load R_L

Switching values

	NO contact		NC contact	
	NAMUR	OC	NAMUR	OC
	I [mA]			
Switching value reached	< 1	< 1	> 3	max. 100
Switching value not reached	> 3	max. 100	< 1	< 1

Switching capacity of B1 and B2 with PNP technology

Due to the PNP technology and the associated protective elements, there is a voltage drop U_v for the load to be operated.

Switching capacity of B1 and B2

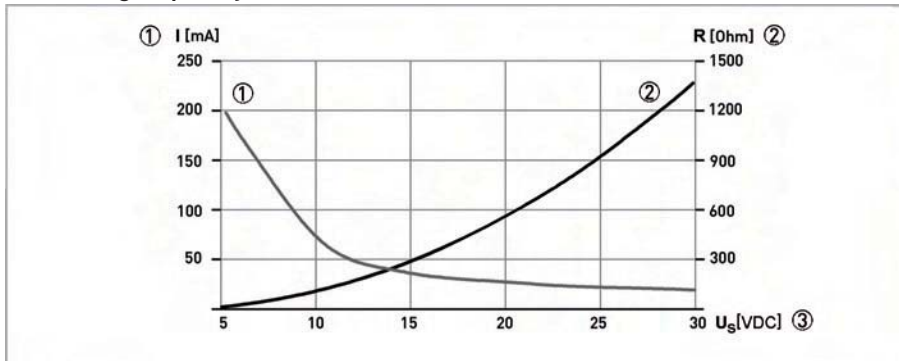

- ① Max. switching current I [mA]
- ② Minimum load impedance R_L [Ohm]
- ③ Power supply U_{ext} .

Power loss of B1 and B2

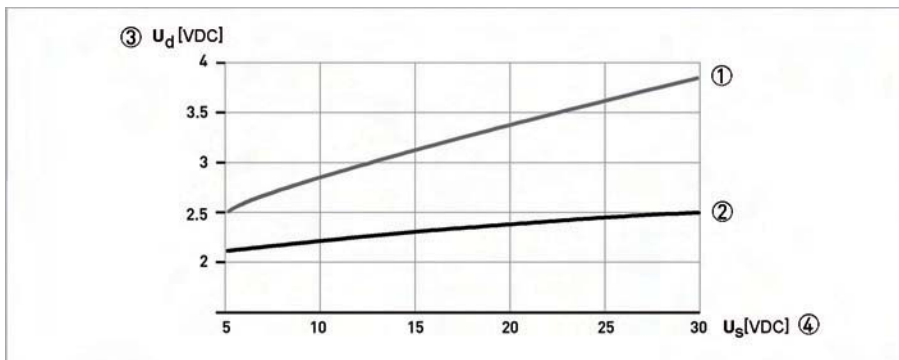

- ① Load impedance R_L 100 Ohm
- ② Load impedance R_L 1000 Ohm
- ③ Power loss U_d
- ④ Power supply U_{ext} .

4.3.4 Switching output B2 as a pulse output

When switching output B2 is used as a pulse output, two separate signal circuits are required. Each signal circuit requires its own power supply.

The total resistance must be adapted so that the total current I_{tot} does not exceed 100 mA.

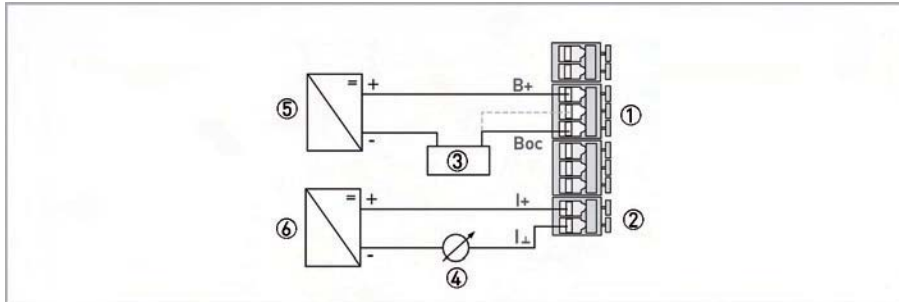

Figure 4-12: Electrical pulse output

- ① Terminal B2
- ② Terminal I
- ③ e.g. counter
- ④ Flow rate measurement 4...20 mA
- ⑤ Pulse output power supply
- ⑥ M10 power supply

Pulse output B2 is a passive "open collector" output which is electrically isolated from the current output and output B1. It can be operated as a low-resistance output or as a NAMUR output.

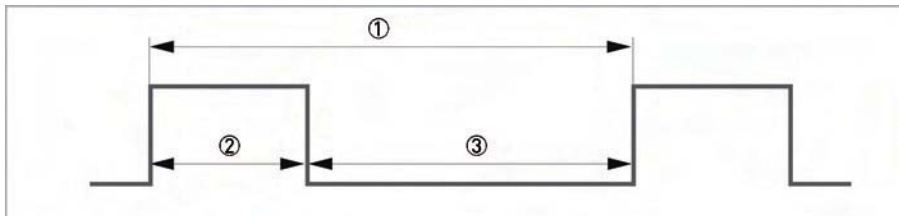

Figure 4-13: Data pulse output

- ① $f_{max} = 10 \text{ Hz}$
- ② t_{on}
- ③ t_{off}

The pulse width t_{on} can be configured from 30...500 ms in the menu of the indicator.

4.3.5 Connection reset input R

Input R can be used as a reset input for the internal counter.

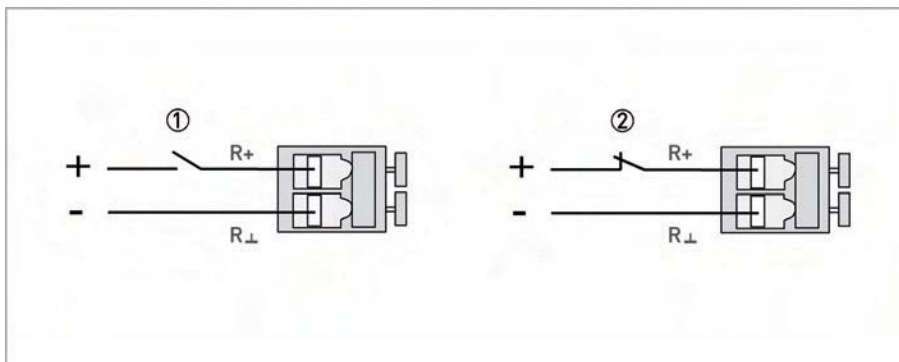

Figure 4-14: Indicator M10 - reset input

- ① Function active HI
- ② Function active LO

This reset input can be activated in the menu of indicator M10, and can be configured to ACTIVE HI or ACTIVE LO. See also chapter "Indicator M10 menu explanations".

If the input is set as ACTIVE LO, an interruption causes the counter to be reset.

Please provide us with the missing information so that we can be of help to you as quickly as possible.

Then please fax this page to the appropriate sales associate. We will then contact you as soon as possible.

Device data

Connection type:						
Nominal connection size:						
Pressure rating:						
Raised face:						
Material of pipeline:						
Indicator:	<input type="checkbox"/> M9	<input type="checkbox"/> M8MG	<input type="checkbox"/> M8EG	<input type="checkbox"/> M10		
Indicator options:	<input type="checkbox"/> K1 ① <input type="checkbox"/> K2 ② <input type="checkbox"/> ESK2A <input type="checkbox"/> Profibus <input type="checkbox"/> ESK-Z	<input type="checkbox"/> K1 ① <input type="checkbox"/> K2 ②				
Approval:	<input type="checkbox"/> Without	<input type="checkbox"/> ATEX	<input type="checkbox"/> FM	<input type="checkbox"/> NEPSI	<input type="checkbox"/> CSA	<input type="checkbox"/> INMETRO

① 1 limit switch

② 2 limit switches

Rating data

Product:			
Operating pressure:		<input type="checkbox"/> Absolute pressure	<input type="checkbox"/> Overpressure
Rated pressure:			
Operating temperature:			
Rated temperature:			
Density:		<input type="checkbox"/> Standard density	<input type="checkbox"/> Operating density
Viscosity:			
Measuring range:			
Comments:			

Contact data

Company:	
Contact person:	
Telephone number:	
Fax number:	
E-mail:	





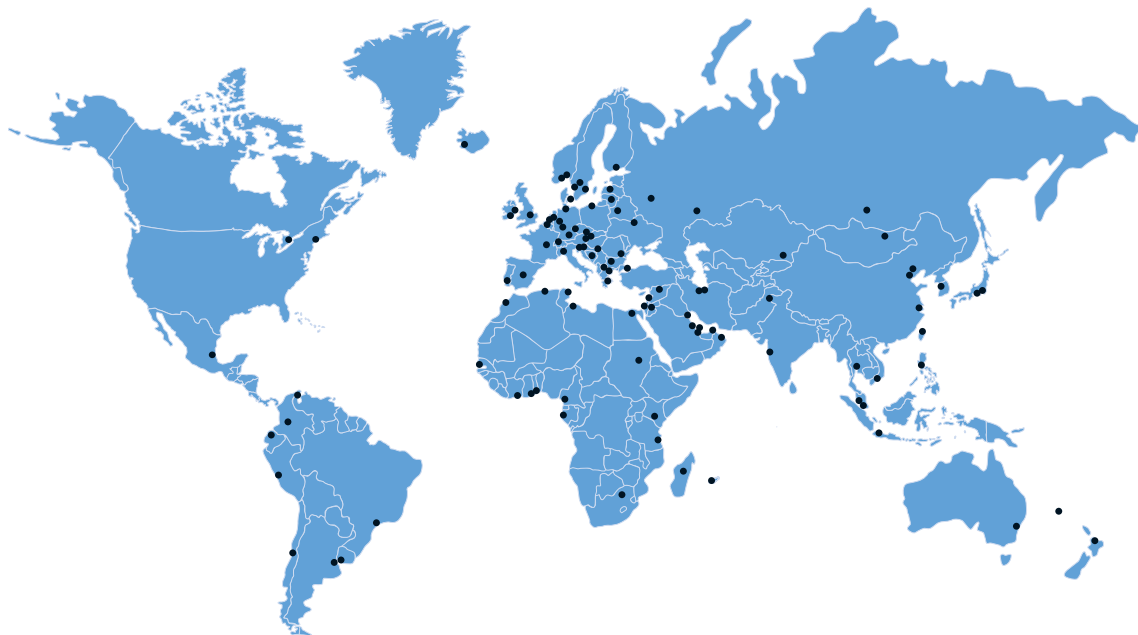

KROHNE product overview

- Electromagnetic flowmeters
- Variable area flowmeters
- Ultrasonic flowmeters
- Mass flowmeters
- Vortex flowmeters
- Flow controllers
- Level meters
- Temperature meters
- Pressure meters
- Analysis products
- Measuring systems for the oil and gas industry
- Measuring systems for sea-going tankers

Head Office KROHNE Messtechnik GmbH & Co. KG
Ludwig-Krohne-Str. 5
D-47058 Duisburg
Tel.: +49 (0)203 301 0
Fax: +49 (0)203 301 10389
info@krohne.de

The current list of all KROHNE contacts and addresses can be found at:
www.krohne.com

KROHNE