

Flow-Alert™ Flow Switch Installation & Maintenance Instructions

HEDLAND
DIVISION OF RACINE FEDERATED INC.

FORM #HLIT 290

8635 Washington Avenue • Racine • Wisconsin 53406-3738
TEL 1-800-HEDLAND • FAX 1-800-CHK-FLOW

I. INTRODUCTION

The Flow-Alert flow meter combines the rugged proven technology of a direct reading, piston-type, variable area flow meter, coupled with electrical contacts utilized to signal at selected flow rates. This combination is sealed against industrial contamination by a NEMA 12 and 13 (IP52/54) rated enclosure.

This product provides a local flow indication and automatically signals the operator or PLC if flow is too high or too low.

Uses of the Flow-Alert flow meter include: bearing lubrication, case drain verification, gun drill cooling, pump flow confirmation, etc.

II. SPECIFICATIONS

Enclosure Rating

- NEMA 12 & 13 (equivalent to IP52 & 54)

Temperature Range

- -20 °F to +240 °F (-20 °C to +116 °C)

Pressure Rating Aluminum/Brass

- Liquids (¼" to 1-½"): 3500 psi (241 bar) maximum with a 3:1 safety factor
- Gases (¼" to 1-½"): 1000 psi (69 bar) maximum with a 10:1 safety factor

Pressure Rating Stainless Steel

- Liquids (¼" to ½"): 6000 psi (414 bar) maximum with a 3:1 safety factor
- Liquids (¾" to 1-½"): 5000 psi (345 bar) maximum with a 3:1 safety factor
- Gases (¼" to 1-½"): 1500 psi (103 bar) maximum with a 10:1 safety factor

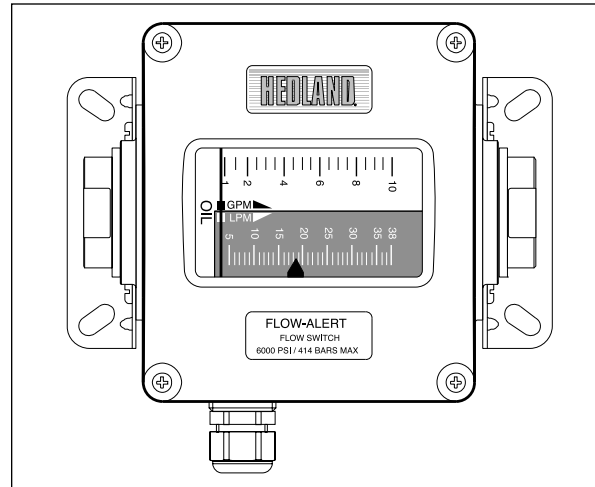

Figure 1. Flow-Alert Flow Meter

Accuracy

- $\pm 2\%$ of full scale

Repeatability

- $\pm 1\%$

Pressure Drop

- See Appendix for specific meter information

Micro Switch

- Single (1) or double (2) switch, prewired single-pole, double-throw (SPDT), UL recognized and CSA certified switch
- Type: SPDT
- Contact Rating VAC: 250 Volt, 10 Amp
- Contact Rating VDC: 125 Volt, 0.5 Amp
- Cable Single Switch: 34", 4-wire, #18 AWG, SO jacket
- Cable Dual Switch: 18", 7-wire, #16 AWG, SO jacket

Reed Switch

- Single (1) or double (2) reed switch, prewired single-pole, single-throw normally open (SPST-NO); or single-pole, single-throw normally closed (SPST-NC); UL recognized and CSA certified switch
- Type: SPST
- Contact Rating (maximum, see Figure 2): Normally Open, 10 Watts; Normally Closed, 5 Watts
- Voltage (maximum at switching): Normally Open, 50 VDC; Normally Closed, 50 VDC
- Current (maximum amps at switching, resistive load): Normally Open, 0.5 Amp; Normally Closed, 0.5 Amps
- Initial Contact Resistance: 0.100 Ohms
- Cable: 15' (4.6m), 4-wire, #22 AWG, PVC jacket

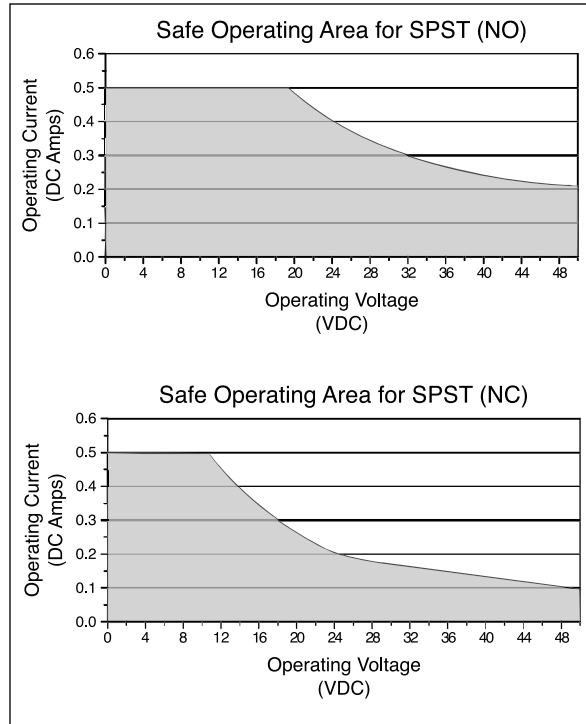

Dimensions

Figure 2. Reed Switch Power Dissipation

A Nominal Port Size	B Length in. (mm)	C Length in. (mm)	D Length in. (mm)	E Width in. (mm)	F Width in. (mm)	G Width in. (mm)	H Width in. (mm)	I Depth in. (mm)	J Offset in. (mm)	K Hole Dia. in. (mm)
¼ (SAE 6)	6.60 (168)	5.27 (134)	6.41 (163)	6.00 (152)	3.23 (82)	3.00 (76)	4.20 (107)	2.94 (75)	1.51 (38)	.31 (8)
½ (SAE 10)	6.60 (168)	5.27 (134)	6.41 (163)	6.00 (152)	3.23 (82)	3.00 (76)	4.20 (107)	2.94 (75)	1.51 (38)	.31 (8)
¾ (SAE 12)	7.20 (183)	5.27 (134)	7.04 (179)	6.00 (152)	3.60 (91)	3.00 (76)	4.20 (107)	2.94 (75)	1.27 (32)	.31 (8)
1 (SAE 16)	7.20 (183)	5.27 (134)	7.04 (179)	6.00 (152)	3.60 (91)	3.00 (76)	4.20 (107)	2.94 (75)	1.27 (32)	.31 (8)
1-¼ (SAE 20)	12.20 (310)	10.68 (271)	11.65 (296)	7.63 (194)	4.84 (123)	3.82 (97)	5.02 (128)	4.50 (114)	2.20 (56)	.31 (8)
1-½ (SAE 24)	12.20 (310)	10.68 (271)	11.65 (296)	7.63 (194)	4.84 (123)	3.82 (97)	5.02 (128)	4.50 (114)	2.20 (56)	.31 (8)

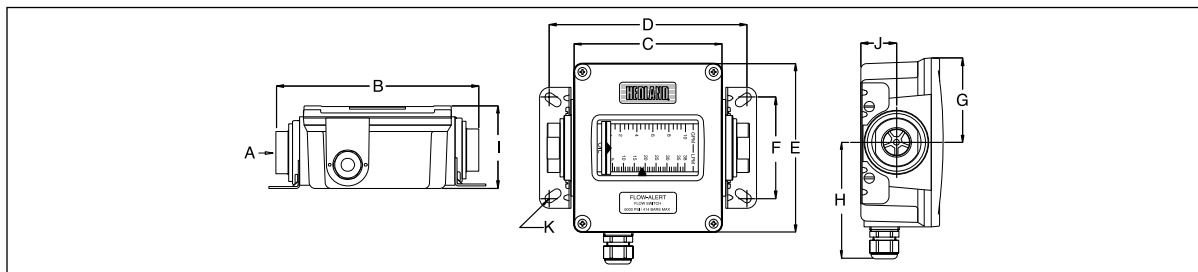

III. INSTALLATION

CAUTION

This product should be installed and serviced by technically qualified personnel trained in maintaining industrial class flow instrumentation and processing equipment.

CAUTION

Read instructions thoroughly before installing the unit. If you have any questions regarding product installation or maintenance, call your local supplier for more information.

CAUTION

This meter may contain residual amounts of test fluid at the time of shipment. This fluid should be removed prior to installation as the fluid may be incompatible or hazardous with some liquids or gases. Failure to follow these instructions could result in damage to the equipment.

CAUTION

This standard meter is unidirectional. Attempts to flow fluids in the opposite direction of the flow arrow will result in the meter acting as a check valve, creating a deadheading situation. If the differential pressure magnitude is great enough, damage to the internal parts of the meter will result.

WARNING

Disconnect electrical power before opening wiring enclosure. Failure to follow these instructions could result in serious personal injury or death and/or damage to the equipment.

WARNING

All wiring should be installed in accordance with the National Electrical Code® and must conform to any applicable state and local codes. Failure to follow these instructions could result in serious personal injury or death and/or damage to the equipment.

CAUTION

Air/gas meters are NOT oxygen cleaned. Use with oxygen may cause hazardous or explosive conditions that may cause serious personal injury and/or damage to the equipment.

Installation Recommendations

The in-line flow meter is a simple device to install. However, the following measures are recommended for reliable, trouble-free operation:

Do - Align pipe accurately. Piping should be accurately aligned and of correct length. The high pressure body of the flow meter can withstand shock and flow/pressure pulsation. However, the piping should be firmly supported by external mounting brackets, both upstream and downstream of the meter, to avoid any pipe flexing actions that could reduce meter life.

Do - Use rigid mounting. If the flow meter inlet or outlet are to be rigidly mounted, and the opposing port is to be connected to flexible hose, the end connected with the flexible hose must be rigidly mounted.

Do - Use Teflon® tape for sealing NPT fitting.

Do - Install unions. Install a union near the inlet or outlet of the meter. This will facilitate quick, easy meter removal and inspection during periodic maintenance procedures.

Do - Mount the meter either horizontally or vertically (flow arrow pointing to either side or straight up). If the meter must be mounted inverted, special inverted scales are available from the factory.

Do - Ensure the fluid is traveling in the direction of the flow arrow (Figure 3 on page 5).

Do - Use at least a 200 mesh (74 micron) filter. The meter will allow particulate to pass that would jam most valves and flow controls. Systems that do not have filtration should be equipped with at least a 200 mesh (74 micron)

filter. Most hydraulic systems already have much finer filtration.

Dirt, ferrous metal or sealing agents, such as Teflon® tape may lodge and cause malfunction. If the meter is jammed at a fixed position, follow cleaning and maintenance instructions.

Don't - Use thread locking compounds as thread sealant.

Don't - Install the flow meter near turbulence producing fittings such as elbows, reducers, close coupled valves, etc. The in-line flow meter does not require flow straighteners or special lengths of straight inlet/outlet piping to stabilize turbulent flow patterns. However, to assure maximum operational reliability, avoid installation of elbows, valves and/or reducers immediately adjacent to the meter inlet.

Don't - Install the meter near fast-acting valves. Fast-acting valves have the potential to create high magnitude hydraulic pressure spikes. These spikes can damage the internal components of the meter, resulting in inaccuracies or malfunction.

Don't - Allow unidirectional meters to be operated against the direction of the flow arrow. The standard flow meter is an unidirectional flow meter. The piston acts as a check valve to block flow in the reverse direction. This causes an excessive pressure differential, which can result in damage to internal meter components. The flow meter is also available in a modified design, which offers a reverse flow by-pass feature to accommodate bi-directional flow.

NOTE: In-line meters with a reverse flow by-pass feature are available. Consult factory for details.

Installing the Flow-Alert

1. See Figure 3. Mount the meter so fluid is traveling in the direction of the flow arrow.
2. See Figure 4. Select a mounting location that is suitable for viewing and product service. To connect the flow meter into the piping system, place an open-ended wrench onto the flow meter wrench flats adjacent to the pipe connection being installed. **DO NOT** wrench on the opposite end of the flow meter or leakage may result.
3. See Figure 5. After installation, rotate meter by hand to view flow scale.

Electrical Connections

Micro Switch Equipped Models

All meters (size ¼" to 1-½") are offered in single (1) switch or double (2) switch models. The single switch model is equipped with a 34" length of 4-wire #18 AWG type SO jacketed cable. The double switch model is equipped with a 18" length of 7-wire #16 AWG type SO jacketed cable.

One Switch – 4-Wire Cable	
Red	Normally Closed (NC)
Black	Normally Open (NO)
White	Common
Green	Ground

Two Switch – 7-Wire Cable – Switch 1	
Red	Normally Closed (NC)
Black	Normally Open (NO)
White	Common

Two Switch – 7-Wire Cable – Switch 2	
Orange	Normally Closed (NC)
Blue	Normally Open (NO)
White/Black	Common
Green	Ground

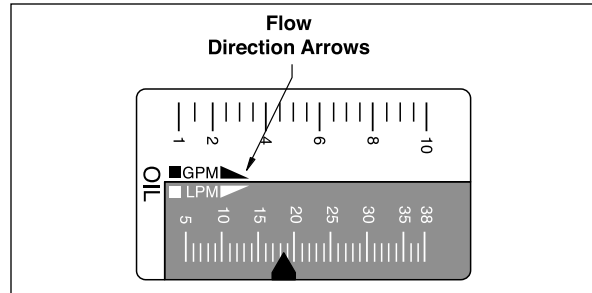

Figure 3. Flow Direction Arrows

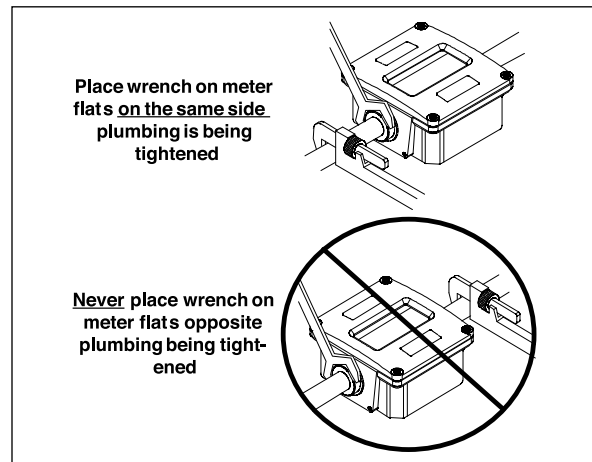

Figure 4. Installing Meter

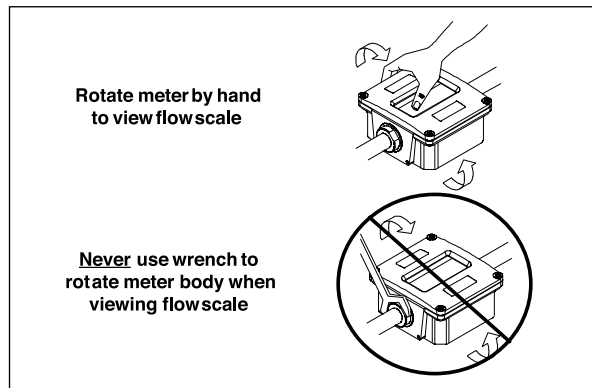

Figure 5. Rotating Meter

A 4-pin Brad Harrison® quick-disconnect plug is available upon special order.

Wiring Configurations

4-Pin Connector used with SPDT Micro Switch	
Red	Normally Closed (NC)
Black	Normally Open (NO)
White	Common
Green	Ground

NOTE: If the factory supplied cable is removed for hard wiring the meter, switches must be connected with 0.187" × 0.020" insulated flag terminals designed for the appropriate wire gauge for the application.

Reed Switch Equipped Models

All meters (size ¼" to 1-½") are offered in single (1) switch or double (2) switch models and come equipped with a 4-pin Hirschmann connector. All units are equipped with a 15' length of 4-wire #22 AWG type PVC jacketed cable.

4-Pin Connector used with SPST Reed Switch	
Red	Switch 1 Contact
Black	Switch 1 Contact
White	Optional Switch 2 Contact
Green	Optional Switch 2 Contact

All Models

The strain relief connection on the outside of the enclosure is water-tight. Be sure to consult local wiring codes before applying power. Some installations will require rigid conduit. By removing the black strain relief connections from the outside of the enclosure, a conduit connection is accessible.

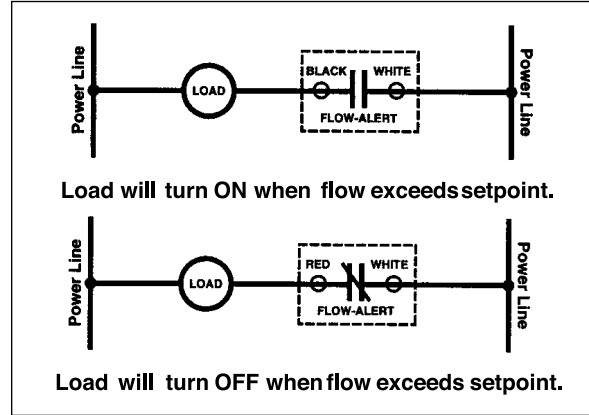

Wiring Configuration for Loads Within Flow-Alert Contact Ratings

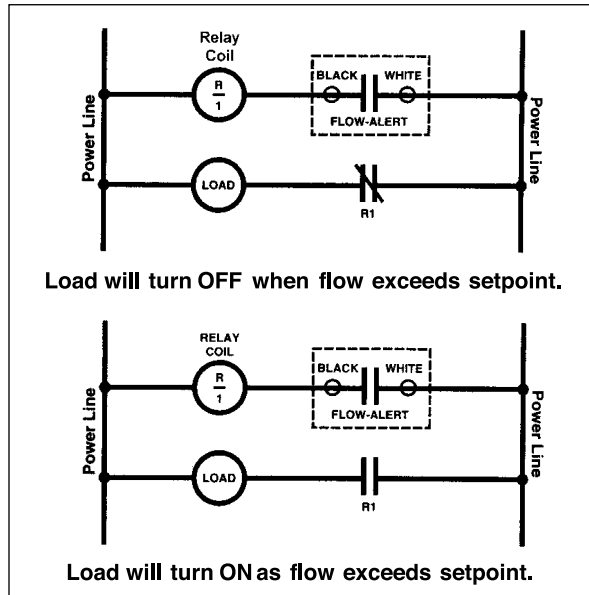

Wiring Configuration for Loads that Exceed Flow-Alert Contact Ratings

IV. OPERATION

NOTE: Refer to the Appendix for application information and fluid charts.

Micro Switch Adjustment

1. Remove cover screws and front cover.

NOTE: On meters equipped with dual micro switches, the right-side is the decreasing flow switch; the left-side is the increasing flow switch.

2. Loosen the screws securing the switching roller and latching rollers to the guide bar. Turn each screw one full turn maximum.
3. All rollers are secured as a set to the spacer strip. Slide the entire roller set until pointer is at the desired setting.

NOTE: The spacer strip controls the maximum distance between rollers. This distance may be shortened when the switching setting is close to the end of the flow scale. Latching rollers may also be removed if the switching setting is close to the end of the flow scale.

4. Make sure roller brackets are flush against the guide bar. Tighten roller screws.
5. For dual switch models, repeat steps 1-4 for left-side switch setting.
6. Install the cover gasket and front cover and secure with screws. To properly seat the cover gasket, tighten cover screws in a crisscross pattern as show in Figure 7.

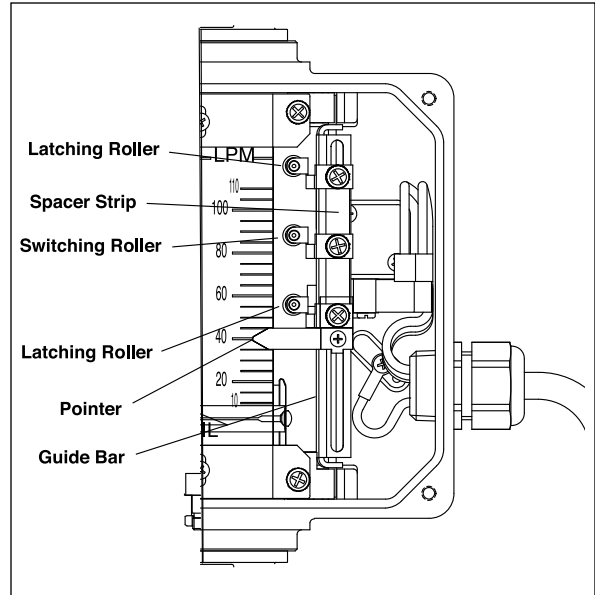

Figure 6. Snap Switch Adjustment

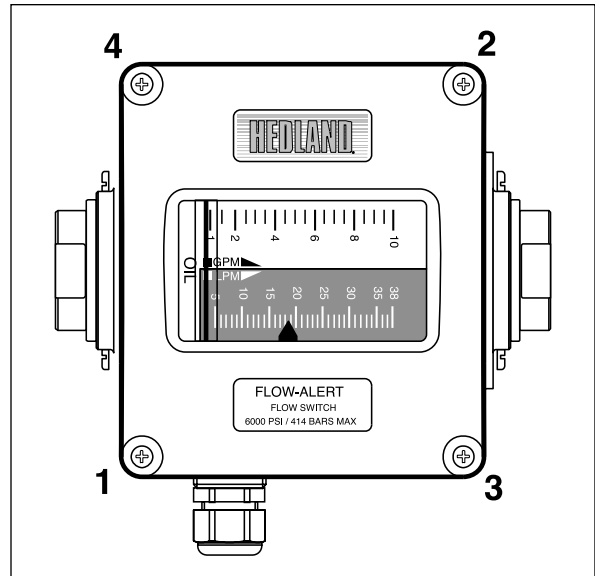
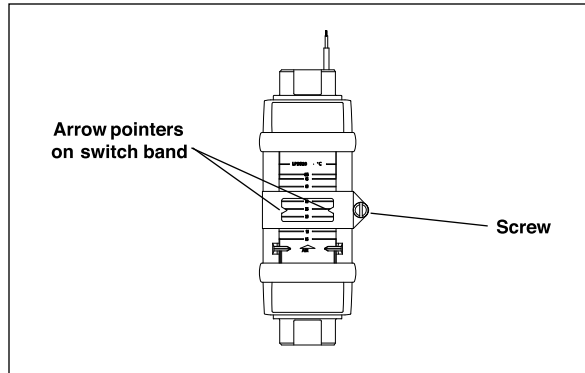

Figure 7. Cover Screw Tightening Sequence

Reed Switch Adjustment - ¼" Models

1. Loosen the screw securing the switch assembly (Figure 8).
2. Slide the switch assembly until the arrow pointers on the switch band are aligned with the desired flow rate indicated on the scale.
3. Tighten the screw.



**Figure 8. Reed Switch
Adjustment - ¼" Models**

Reed Switch Adjustment - ¼" to 1-½" Models

1. Remove cover screws and front cover.
2. Loosen the screw securing the switch assembly (Figure 9).

NOTE: On meters equipped with dual switches, the right-side is the decreasing flow switch; the left-side is the increasing flow switch.

3. Slide the switch assembly until the arrow pointer aligns with the desired flow rate indicated on the scale.
4. Tighten the screw.
5. For dual switch models, repeat steps 1-4 for left-side setting.
6. Install the front cover and gasket. To properly seat the cover gasket, tighten cover screws in a crisscross pattern as shown in Figure 7 on page 7.

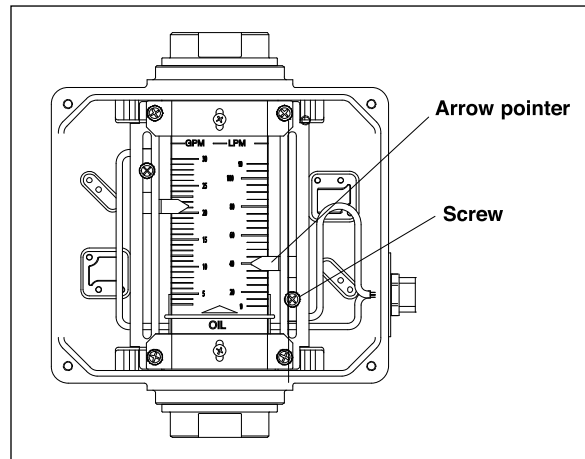

**Figure 9. Reed Switch
Adjustment - ¼" - 1-½" Models
(Dual Switch Shown)**

V. MAINTENANCE



WARNING

Disconnect electrical power before removing meter cover. Failure to follow these instructions could result in serious personal injury or death and/or damage to the equipment.

Switch Replacement

Micro Switch (Figure 10 on page 10)

1. Disconnect cable connection to the meter.
2. Remove screws securing cover and remove cover.
3. Note the positions of the colored wire connections on the switch. Disconnect the wires from the switch.
4. Remove the two mounting bracket screws at the bottom of the meter.
5. Remove mounting bracket/switch assembly from the meter. Remove the two screws securing switch to mounting bracket.
6. Install new switch to mounting bracket using screws removed in step 5.
7. Install wires to terminals on switch as marked in step 3.
8. Install mounting bracket/switch assembly to meter using screws removed in step 4.
9. Install the front cover and gasket. To properly seat the cover gasket, tighten cover screws in a crisscross pattern as shown in Figure 7 on page 7.

Reed Switch (Figure 11 on page 10)

1. Disconnect the Hirschmann connector and remove connector from wires.
2. Remove screws securing cover and remove cover.
3. Remove the two scale mounting screws.
4. Remove the screws securing the two mounting brackets and remove the brackets.
5. Loosen the two slide bracket screws.
6. Remove the switch mounting screw and remove mounting block/switch assembly from slide bracket.
7. Remove the two mounting screws securing switch to mounting block and pointer. Make note of switch position.
8. Install new switch to mounting block and pointer using screws removed in step 7.
9. Remove the strain relief.
10. Install mounting block/switch assembly to slide bracket using screw removed in step 6.
11. Tighten the slide bracket screws.
12. Install strain relief.
13. Install mounting brackets to scale using scale mounting screws. Do not fully tighten yet.
14. Secure mounting brackets using screws removed in step 4.
15. Tighten screws installed in step 10.
16. Solder Hirschmann connector to new switch wires.

NOTE: For ¼", ½", ¾" and 1" units, wire should be cut to 5" length. For 1-¼" and 1-½" units, wire should be cut to 10" length.

17. Install the front cover and gasket. To properly seat the cover gasket, tighten cover screws in a crisscross pattern as shown in Figure 7 on page 7.

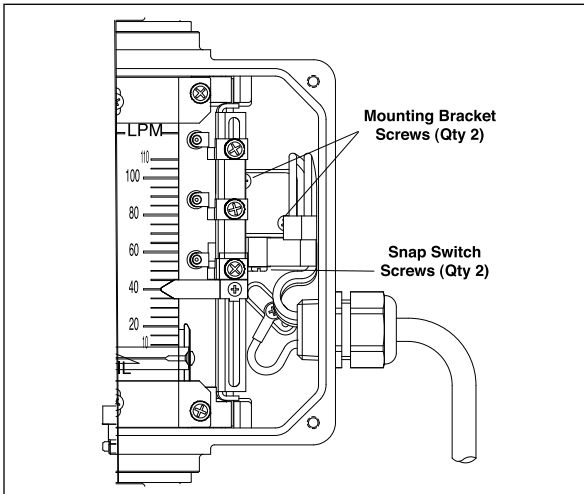

Figure 10. Micro Switch Replacement

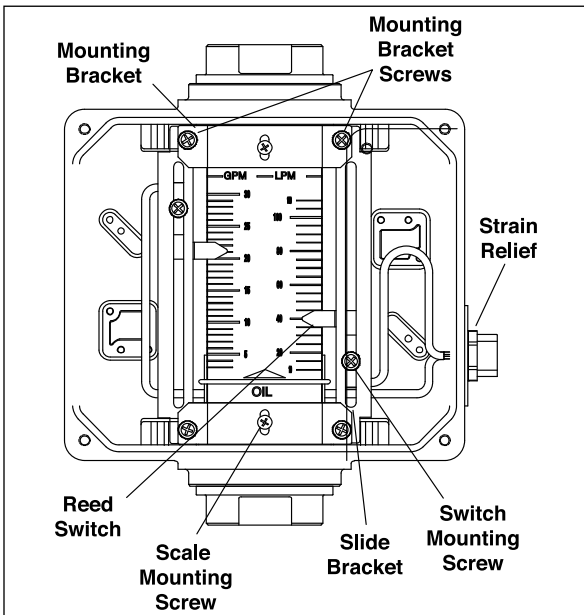

Figure 11. Reed Switch Replacement

Cartridge Cleaning (Figure 12 on page 11)

1. Disconnect the meter cable.
2. Remove the meter from the line. Remove excess piping from meter.

! WARNING

Before attempting to remove the meter from the line, check the system to confirm that line pressure has been reduced to zero PSI. Failure to follow these instructions could result in serious personal injury or death and/or damage to the equipment.

NOTE: It is not necessary to remove the aluminum housing from the meter to remove it from the line.

3. Thoroughly wipe off the entire meter surface using mild detergent or isopropyl alcohol.

! CAUTION

Do not use aromatic hydrocarbons, halogenated hydrocarbons, ketones or ester based fluids on polycarbonate lens. Failure to follow these instructions could result in damage to the meter.

4. Remove the inlet end fitting, retaining spring, and metering cone/spider plate assembly from the cartridge.
5. Gently push the cartridge assembly towards the outlet port while holding magnetic indicator assembly in place.
6. The cartridge internal parts are secured with a retaining ring. Remove the retaining ring and the remaining internal parts from the cartridge.

NOTE: If internal parts do not slide freely from cartridge, use a wooden dowel inserted into the outlet port of the meter to push parts out.

7. Place all parts on a clean work surface. Clean and inspect all parts. Replace any that appear worn or damaged. Check inlet port O-ring for damage and replace if required.
8. Reassemble spring, then piston/magnet assembly and retaining ring into cartridge.
9. Gently push cartridge assembly into housing while holding the magnetic flow indicator in position.
10. Install metering cone/spider plate assembly, retaining spring, and secure with inlet fitting.
11. Reinstall meter to the line. Reconnect electrical power.

Quick Re-Coupling

This piston-type variable area flow meter is inherently less sensitive to shock and vibration than other variable area designs. The unique magnetic coupling also eliminates the need for mechanical linkages that can wear or loosen over the functional life of the meter.

However, on occasion, a pressure spike or extreme flow surge can cause the piston to move at such rapid speed that it disconnects the piston magnet and the external indicator ring. If this occurs, use one of these procedures to re-couple the magnet and the external indicator ring:

- If the system permits, simply change flow rate from “no flow” to “full flow” allowing the moving piston to magnetically re-couple to the indicator ring.
- Remove cover and manually re-attach external flow indicator to internal magnet/piston assembly.
- For rigorous cyclical applications where de-coupling may occur frequently, consult the technical services staff for further recommendations.

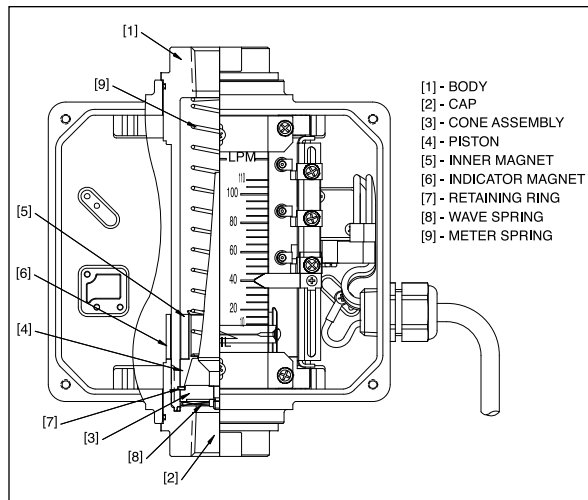

Figure 12. Cartridge Components

VI. APPENDIX

Application Information - Liquid

Viscosity Effect (SUS/cSt)

The design utilizes a precision machined, sharp-edged orifice and biasing calibration spring that assures operating stability and accuracy over the wide viscosity range common to many fluids. Generally, high flow models of each meter size provide good accuracy over a viscosity range of 40 to 500 SUS (4.2 to 109 cSt).

Density Effect (specific gravity)

Any fluid density change from stated standards has a proportional effect on meter accuracy. Special scales can be supplied if actual specific gravity decreases accuracy beyond application limits. Corrections for more or less dense fluids can be made to standard scales using the following correction factor:

$$\sqrt{\frac{1.0}{\text{Specific Gravity}}} \quad \text{for water/water-based meters}$$

$$\sqrt{\frac{0.876}{\text{Specific Gravity}}} \quad \text{for petroleum-based meters}$$

Application Information - Pneumatic

NOTE: Pressure and temperature readings must be taken at the flow meter inlet to ensure accurate correction factors.

The pneumatic flow meter is offered with a standard graduated dual scale, calibrated for air in standard cubic feet per minute (scfm) at 1.0 s.g. (70 °F @ 100 psi), and liter per second (lps) at 1.0 s.g. (21 °C @ 6.9 bar).

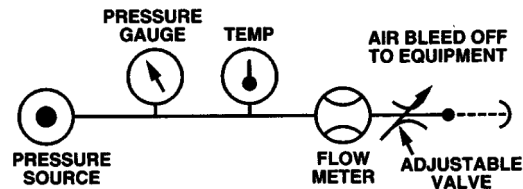

Conversion Chart

The Conversion Chart provides a series of simplified mathematical formulas to “correct” the graduated scale for changes in pressure (Table 1), temperature (Table 2), and/or specific gravity (Table 3). *Special scales can be made to accommodate other pressures, temperatures and specific gravity.*

The Conversion Chart can also be used to “correct” (adjust) the Multi-pressure Flow Scale to indicate flow rates in applications beyond the parameters stated on the scale.

To adjust Pressures beyond (above or below) scale limits:

Step 1. Locate point at which the brightly colored indicator line intersects the vertical 100 PSIG pressure line.

Step 2. Divide this reading by the Pressure Correction Factor (f_1) indicated in the Conversion Chart.

To adjust for changes in temperature:

Step 1. Divide the 100 PSIG flow rate reading by the Temperature Correction Factor (f_2).

To adjust for changes in Specific Gravity:

Step 1. Establish the square root of the new specific gravity.

Step 2. Divide the 100 PSIG flow rate reading by the Specific Gravity Correction Factor (f_3).

DETERMINE FLOW RATES USING DIFFERENT PRESSURES & TEMPERATURES										
$\text{scfm (actual)} = \frac{\text{scfm (indicated)}}{f_1 \times f_2 \times f_3}$ Where f_1 = Conversion factor for inlet pressure f_2 = Conversion factor for temperature f_3 = Conversion factor for specific gravity										
TABLE 1 PRESSURE CORRECTION FACTOR (f_1) Operating Pressure										
psig	25	50	75	100	125	150	175	200	225	250
BAR	1.7	3.5	5.2	6.9	8.6	10.4	12.1	13.8	15.5	17.2
kPa	172	345	517	689	862	1034	1207	1379	1551	1724
f_1	1.700	1.331	1.131	1.00	.902	.835	.778	.731	.692	.658
$f_1 = \sqrt{\frac{114.7}{14.7 + \text{psig}}}$ $f_1 = \sqrt{\frac{7.914}{1.014 + \text{BAR}}}$ $f_1 = \sqrt{\frac{790.857}{101.357 + \text{kPa}}}$										
TABLE 2 TEMPERATURE CORRECTION FACTOR (f_2)										
°F	+10	+30	+50	+70	+90	+110	+130	+150	+170	+190
°C	-12.2	-1.1	+9.9	+21.0	+32.1	+43	+54	+65	+76	+88
f_2	.942	.962	.981	1.00	1.018	1.037	1.055	1.072	1.090	1.107
$f_2 = \sqrt{\frac{460 + \text{°F}}{530}}$ $f_2 = \sqrt{\frac{273 + \text{°C}}{293}}$										
TABLE 3 SPECIFIC GRAVITY CORRECTION FACTOR (f_3)										
$f_3 = \sqrt{\text{Sp. Gr.}}$										

Figure 13. Conversion Chart

FLUID SELECTION CHART	Specific Gravity	Correction Factor Std. Scale	Aluminum	Brass	T316 SST	T303 SST	Viton®	EPR	Polycarbonate	Nylon	Pyrex®
Air	1.0	1.000	R	R	R	R	R	R	R	R	R
Argon(A)	1.38	1.175	R	R	R	R	R	R	R	R	R
Carbon Dioxide(CO ₂)	1.53	1.237	R	R	R	R	R	R	R	R	R
Freon 11 (CCl ₃ F)	4.92	2.218	R	R	R	R	R	R	R	R	R
Freon 12 (CCl ₂ F)	4.26	2.060	R	R	R	R	R	R	R	R	R
Helium(HE)	0.14	0.374	R	R	R	R	R	R	R	R	R
Hydrogen (H ₂)	0.07	0.265	R	R	R	R	R	R	R	R	R
Natural Gas	0.60	0.775	C	C	R	C	R	N	C	R	R
Nitrogen (N ₂)	0.97	0.985	C	C	R	R	R	R	C	R	R
Oxygen (O ₂)	1.10	1.049	R	R	R	R	R	R	R	R	R
Propane (C ₃ H ₈)	1.57	1.253	R	R	R	R	R	N	N	R	R

R = Recommended
 N = Not recommended
 C = Consult Factory

Figure 14. Fluid Selection Chart

Flow vs. Pressure Drop

Petroleum Fluids

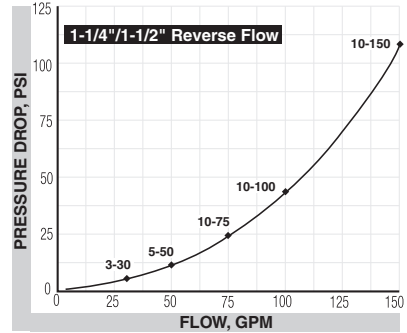
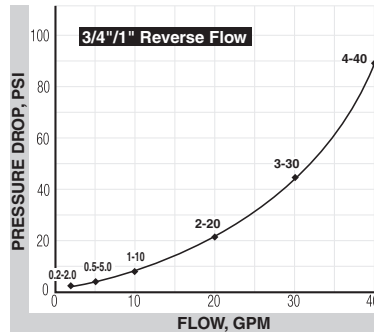
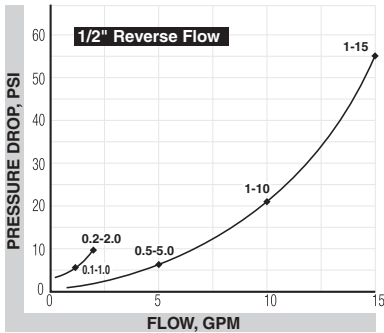
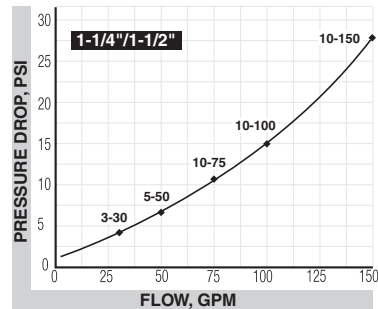
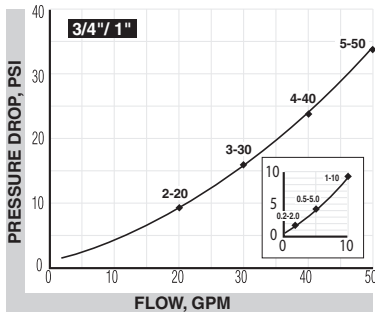
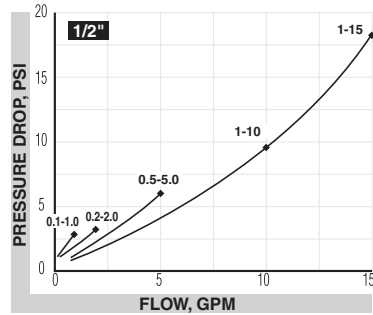
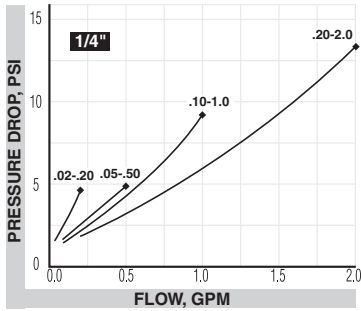

Phosphate Ester

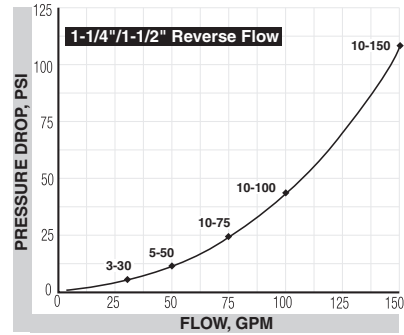
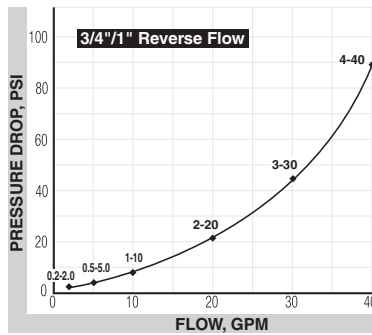
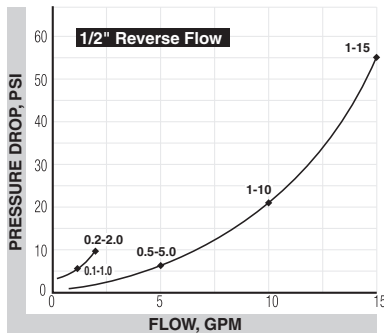
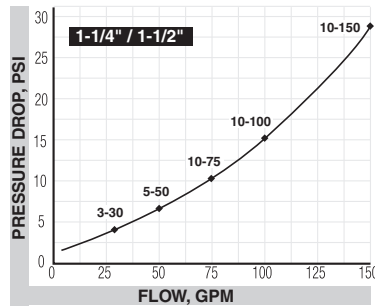
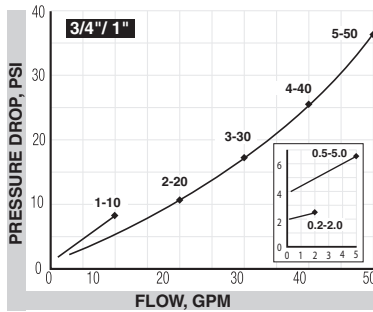
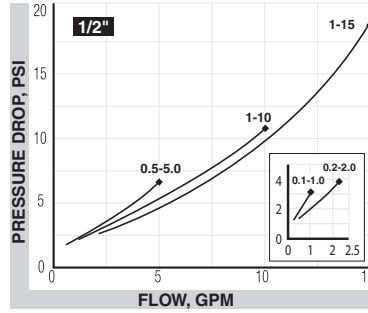
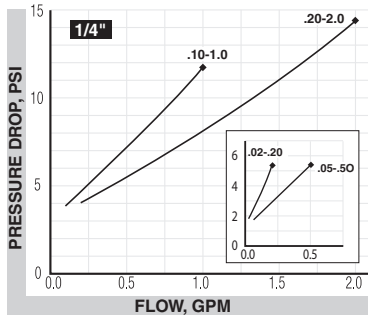

A.P.I. Oil

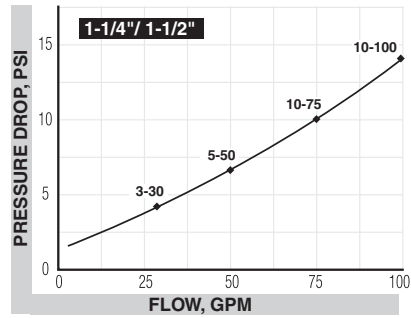
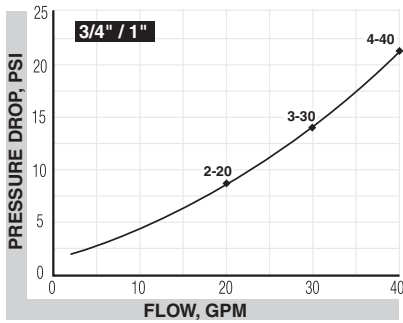
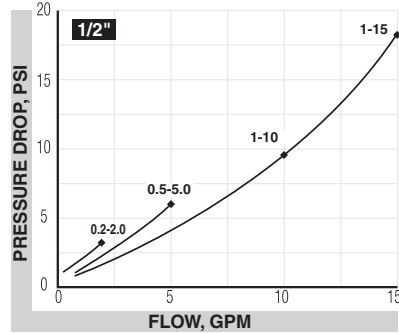
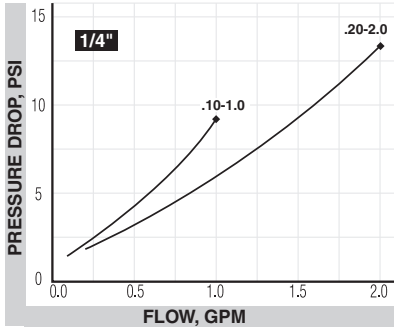

Water-based Fluids

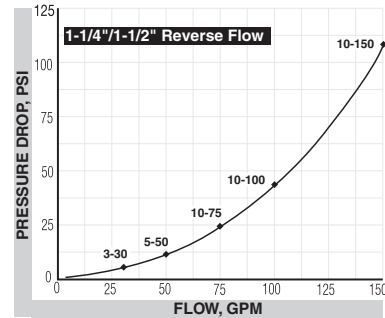
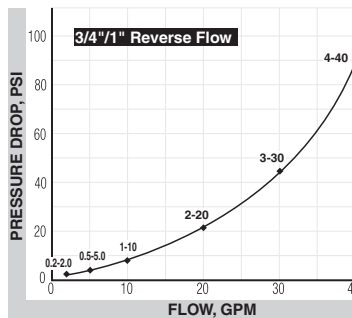
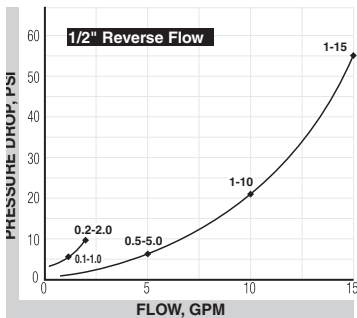
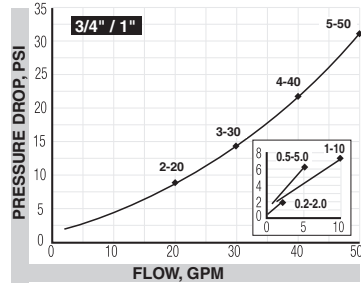
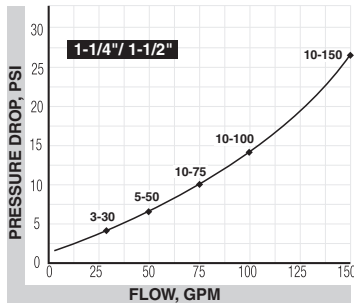
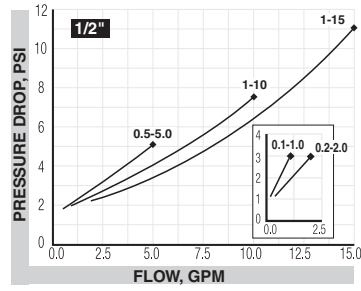
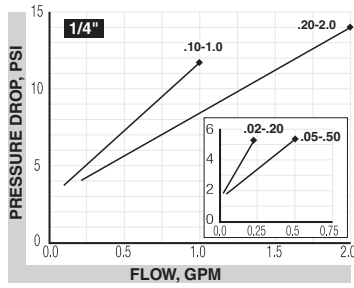

Water

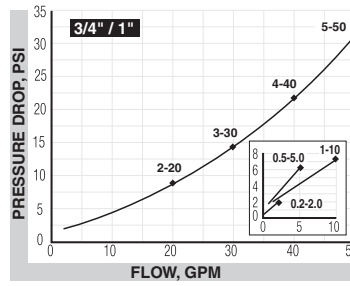
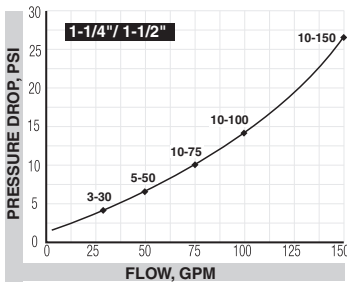
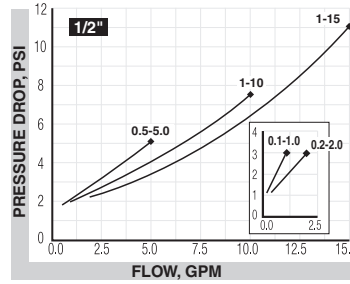
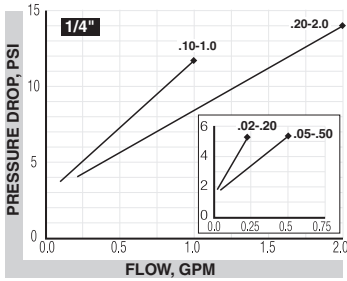

Caustic and Corrosive Liquids

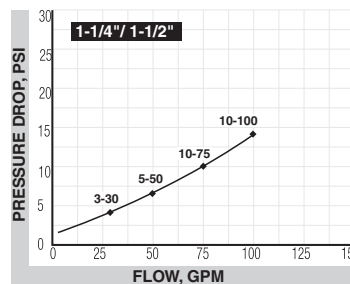
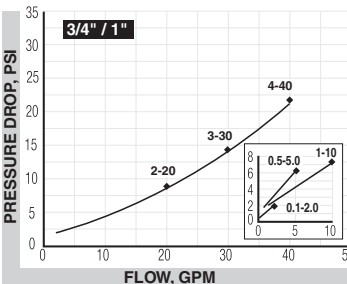
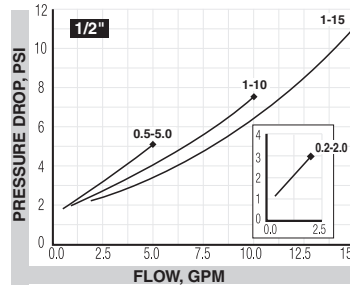
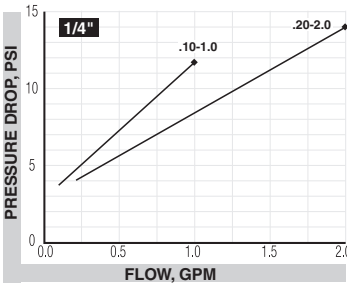

Air / Compressed Gases

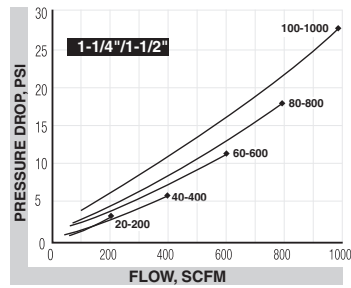
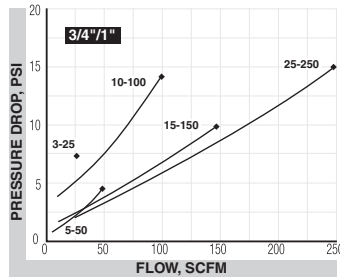
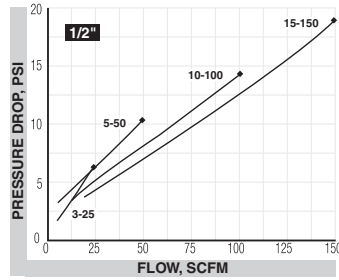
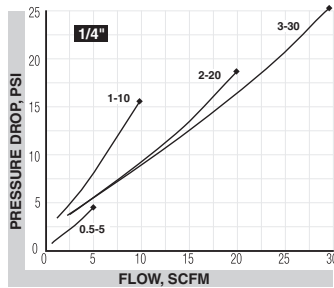

Air / Caustic and Corrosive Gases

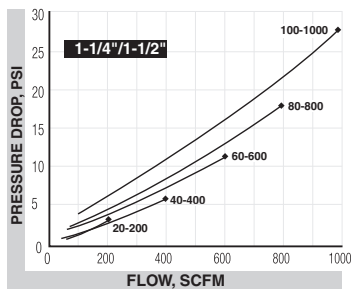
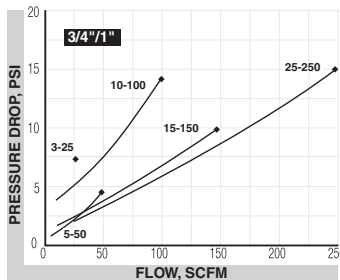
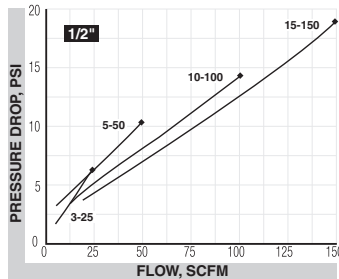
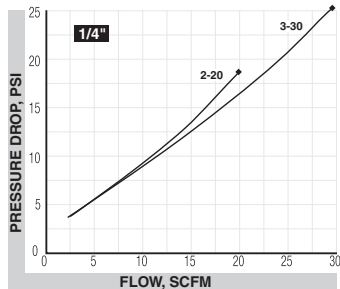

LIMITED WARRANTY and DISCLAIMER

Hedland, Division of Racine Federated Inc. warrants to the end purchaser, for a period of one year from the date of shipment from the factory, that all flow meters manufactured by it are free from defects in materials and workmanship. This warranty does not cover products that have been damaged due to misapplication, abuse, lack of maintenance, or improper installation. Hedland's obligation under this warranty is limited to the repair or replacement of a defective product, at no charge to the end purchaser, if the product is inspected by Hedland and found to be defective. Repair or replacement is at Hedland's discretion. A returned goods authorization (RGA) number must be obtained from Hedland before any product may be returned for warranty repair or replacement. The product must be thoroughly cleaned and any process chemicals removed before it will be accepted for return.

The purchaser must determine the applicability of the product for its desired use and assumes all risks in connection therewith. Hedland assumes no responsibility or liability for any omissions or errors in connection with the use of its products. Hedland will under no circumstances be liable for any incidental, consequential, contingent or special damages or loss to any person or property arising out of the failure of any product, component or accessory.

All expressed or implied warranties, including **the implied warranty of merchantability and the implied warranty of fitness for a particular purpose or application are expressly disclaimed** and shall not apply to any products sold or services rendered by Hedland.

The above warranty supersedes and is in lieu of all other warranties, either expressed or implied and all other obligations or liabilities. No agent or representative has any authority to alter the terms of this warranty in any way.



DIVISION OF RACINE FEDERATED INC.

8635 Washington Avenue, Racine, WI 53406-3738

Telephone: 262-639-6770 or 800-HEDLAND

Fax: 262-639-2267 or 800-CHK-FLOW

www.hedland.com hedlandtechhelp@racinefed.com

Materials & specifications are subject to change without notice.

HEDLAND is a registered trademark of Racine Federated Inc.

Flow-Alert is a trademark of Racine Federated Inc.

TEFLON is a registered trademark of E.I. du Pont de Nemours and Company.

PYREX is a registered trademark of Corning Glass Works Corporation.

BRAD HARRISON is a registered trademark of Woodhead Industries, Inc.

NATIONAL ELECTRICAL CODE is a registered trademark of NFPA.