

CAUTION!

1. Follow instructions carefully to avoid personal injury.
2. Do not exceed the maximum pressure or temperature specifications.
3. Mounting the Chlorine System in an outdoor box, in areas with elevated temperatures, may cause damage to the system if the enclosure's internal temperature exceeds the temperature specification of the Chlorine Analyzer.
4. Do not alter product construction.
5. For use with clean fresh water only.
6. Disconnect AC power before opening wiring enclosure.
7. This panel system uses AC voltages. Wiring should be done by qualified personnel only.

Section I – 4630 Chlorine Analyzer

1. System Inventory	p.2	6. Component Identification	p.5	10. Sensor Installation	p.10
2. Quick Start Up Guide	p.2	7. Mounting	p.6	11. Tubing Connections	p.11
3. Description	p.3	8. Wiring Input	p.7	12. Water Flow	p.11
4. Dimensions	p.3	8.1 Wiring Output	p.8		
5. Panel Assembly	p.4	9. Electrical Box Schematic	p.9		

Section II – 8630 Chlorine Transmitter

1. The View Mode	p.12	5.1 pH Offset	p.18	7.2 Zero Point Calibration	p.20
2. Editing Procedure	p.12	5.2 pH Slope	p.18	7.3 In Process Calibration	p.21
2.1 Example: Calibration	p.13	5.3 Manual pH Compensation	p.19	8. Output Settings	p.21
3. Calibrate Menu Definitions	p.14	6. Cl Sensor Conditioning	p.19	8.1 Current Loop Settings	p.21
4. Options Menu Definitions	p.16	7. Chlorine Calibration	p.20	8.2 Relay Functions	p.22
5. pH Sensor Calibration	p.18	7.1 Cl Sensor Temperature	p.20	8.3 Relay Settings	p.23

Section III – 2650-7 pH and 2750-7 Cl Amperometric Electronics

1. Installation	p.24	2. Wiring	p.25
-----------------	------	-----------	------

Section IV – 2630 Amperometric Chlorine Electrode

1. Operation	p.26	2. Overview	p.26	3. Calibration	p.27
--------------	------	-------------	------	----------------	------

Section V – 2724 DryLoc pH Electrode

1. Dimensions	p.28	2. pH System Calibration	p.29	3. Electrode Data Code	p.30
---------------	------	--------------------------	------	------------------------	------

Section VI – Appendix

1. Maintenance 4630	p.31	3.2 Cleaning	p.35	11. Specifications 2750-7	p.44
1.1 Cleaning	p.31	4. Troubleshooting 4630	p.36	12. Specifications 2630	p.45
1.2 O-Ring Installation	p.32	5. Troubleshooting 8630	p.37	13. Specifications 2724	p.46
1.3 Flow cell Assembly	p.33	5.1 Error Messages	p.38	14. Ordering 4630	p.47
2. Maintenance 2630	p.34	6. Troubleshooting 2630	p.40	15. Ordering 8630	p.47
2.1 Storage	p.34	7. Troubleshooting 2750-7	p.41	16. Ordering 2630	p.48
2.2 Disposal	p.34	8. Specifications 4630	p.42	17. Ordering 2724	p.48
3. Maintenance 2724	p.35	9. Specifications 8630	p.43	18. Ordering 2750-7	p.48
3.1 Electrode Care/Application	p.35	10. Specifications 2650	p.44		

1. 4630 Chlorine Analyzer System Inventory

1. Chlorine panel assembly
 - a. Built-in pressure regulator 15 to 120 psi.
 - b. 3/8 inch hose barb connectors.
2. 1 each 3-2630-2 Free Chlorine sensor with protective cap
 - a. 1 spare membrane cap
 - b. 1 bottle of electrolyte solution
 - c. 1 syringe needle (taped to bottle)
 - d. 1 syringe
3. 1 each Flat pH sensor 3-2724-00 (159 001 545) (3-4630-21 model only)
4. Manual package
 - a. English panel assembly manual
 - b. CD with multi-language manuals
 - c. Wall mounting hardware
 - d. Drill template
5. 1 each North American Type B power cord
6. Customer supplied
 - a. 3/8" hose input and drain
 - b. Hose clamps

2. Quick Start Up Guide

Follow the steps below to set up a new Chlorine Analyzer System. Refer to the individual component manuals for detailed information.

Step 1. Mount the panel on a vertical flat surface using appropriate hardware.



Do not turn on power at this time.

Step 2. Open the wiring enclosure and wire input power (see section 8 and 8.1: Wiring Inputs/Outputs).

Step 3. Wire any 4 to 20 mA and relay output.

Step 4. Remove sensor access plugs from the flow cell (Figure 1). If the optional pH sensor is *NOT* used, do not remove the left-side plug from the flow cell.

Step 5. Install sensor into the electronics (see section 10: Sensor Installation). Chlorine sensor is installed in the right-side access port, optional pH sensor is installed in the left-side access port.

Step 6. Remove the protective cap from the electrode tip and install the electrode into the flow cell. (Keep the electrode tip cap in a safe place for future use. It is recommended to use the cap to protect the sensor during the removal of the electrode for cleaning or maintenance of the flow cell).

NOTE: All new chlorine and pH sensors require calibration during the start up of a system and also throughout the life of the sensor. A new chlorine sensor requires a 4-hour conditioning period with power on and water flowing past the sensor prior to calibration. Refer to section II, section 7 for chlorine calibration and set up procedure.

NOTE: If optional pH sensor is not being used, pH must be "hard-coded" into the system. Refer to section II, section 5.3 for manual pH compensation. If optional pH sensor is installed, refer to section II, section 5 to calibrate pH electrode.

Step 7. Repeat step 5 and 6 if the optional pH sensor is being used.

Step 8. Install the influent water source to the "Inlet Port" nipple assembly of the flow cell. Install 3/8 inch tubing and secure with a hose clamp. (Not included. See section I, section 10)

Step 9. Install 3/8 inch tubing and secure with a hose clamp on the "Drain" port and direct the tube to a proper drain. (Not included. See section I, section 10)

Step 10. Verify the inlet and drain ball valves are in the open position and the sample port is in the off position (See section I, section 11: Tubing Connections).

Step 11. Turn on the influent water source and check the system for leaks.

Step 12. Apply power to the system, and allow system to initialize. Calibrate per instructions (See section II, sections 5 and 7).

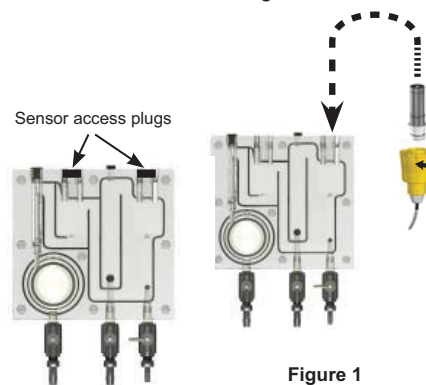

3. Description

The Signet Chlorine Analyzer System is an integrated, all-in-one chlorine panel system designed to measure free chlorine in drinking water and clean fresh water treatment applications.

Features:

- Complete chlorine analyzer system allows quick setup and easy installation. Connect to a water source and plug it in.
- Unique integrated clear flow cell combines sensors, flow regulator, filter and variable area flow indicator in one compact unit.
- Built-in variable area flow indicator facilitates flow rate confirmation at a glance.
- Integrated flow regulator with removable filter accepts inlet pressures of 1 to 8 bar (15 to 120 psi) while maintaining constant flow and minimal pressure to the sensors.
- Water flows vertically into sensor tip, eliminating bubble entrapment. Raised exit in flow cell sensor chamber ensures sensors stay submerged even when system and flow is turned off.
- Flow cell accommodates two sensors; one chlorine and an optional pH sensor.
- Automatic pH and temperature compensation or manual pH value input capability for chlorine reading accuracy.
- Easy viewing of the transmitter via the bright backlit LCD display.
- Moisture proof NEMA 4X wiring enclosure.

Additional information can be found in the individual product manuals, refer to www.gfsignet.com. Click on Product Manuals under the Signet Quick Links section.

- 8630-3P Chlorine Transmitter Manual
- 2630-2 Amperometric Chlorine Electrode Manual
- 2650 Amperometric Electronics Manual
- 2724 pH/ORP Electrode Manual
- 2750-7 pH Electronics Manual

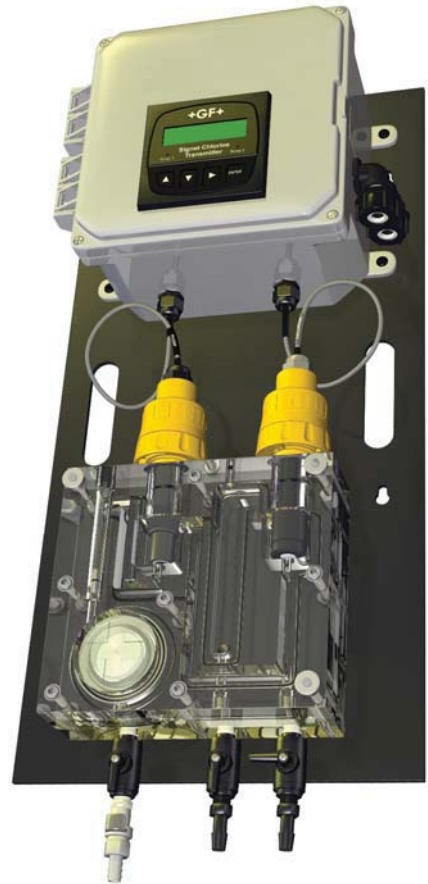

4. Dimensions

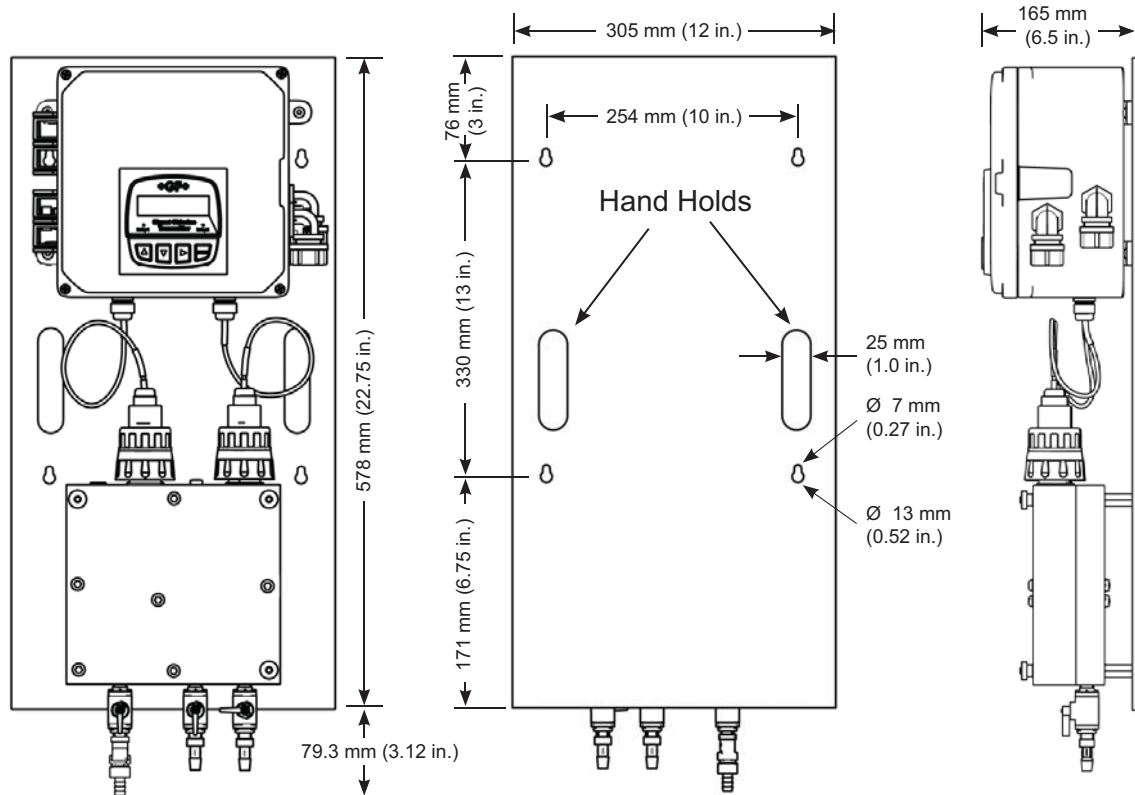

5. Panel Assembly

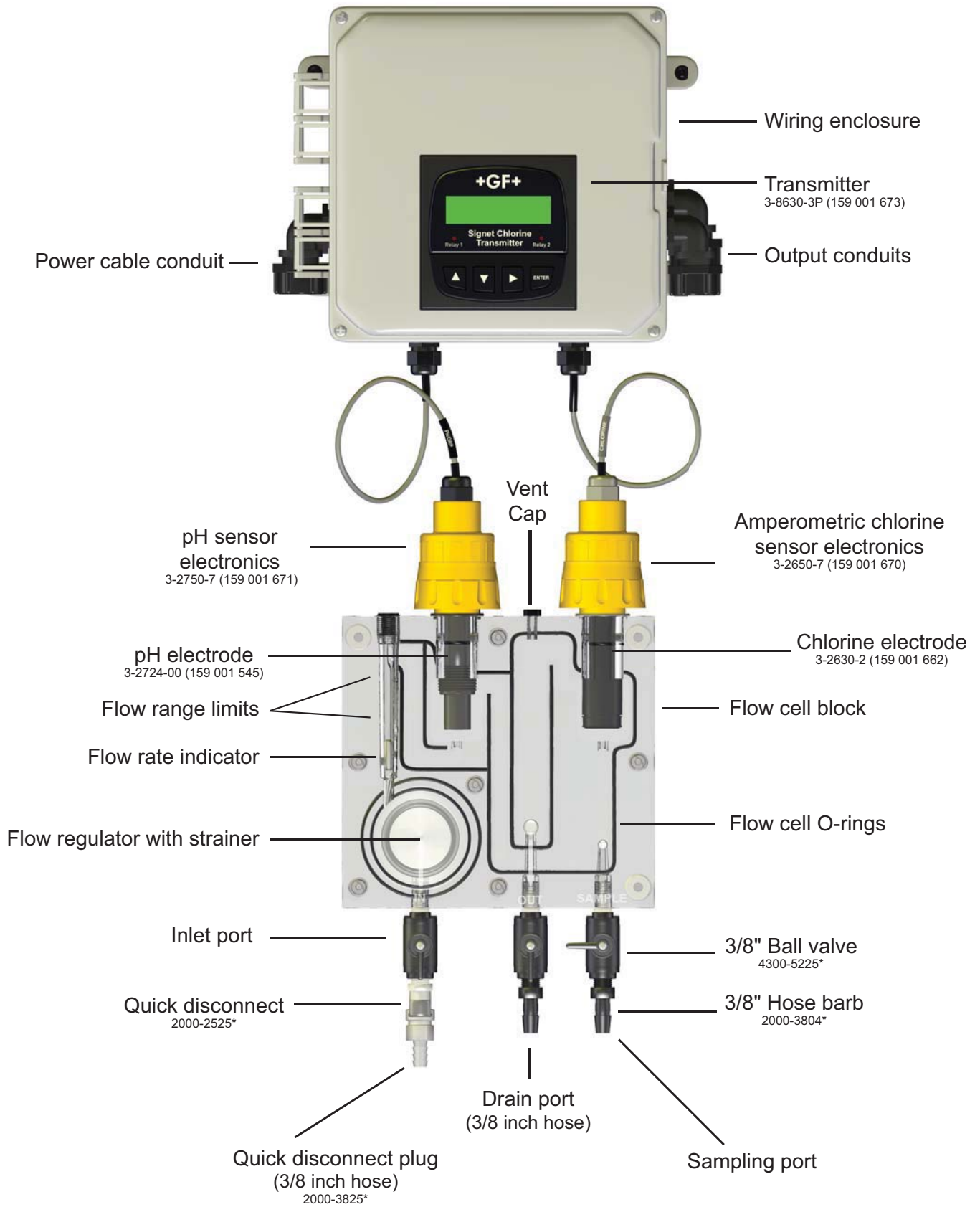

* Contact factory for quote

6. Component Identification: Flow Cell

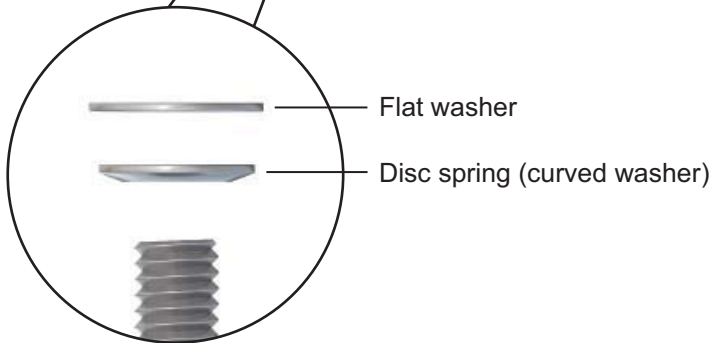
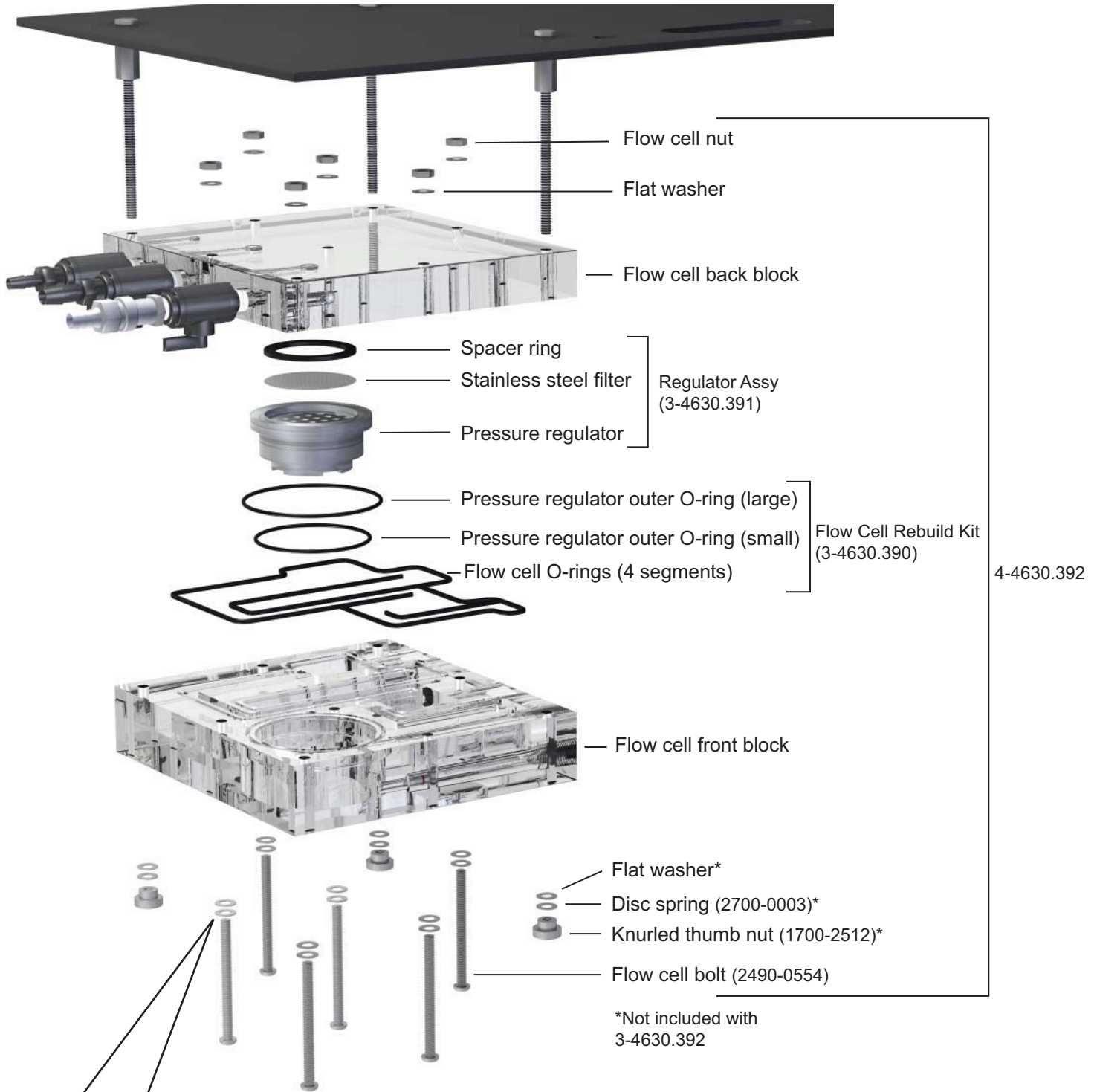

Included in kit 3-4630.390	
Item	Quantity
Flow cell nut	6
Flat washer	15
Disc spring	9
Knurled thumb nut	3
Flow cell bolt	6

7. Mounting

- Indoors is recommended.
- Mount the panel according to local electrical, building, and or plumbing codes and seismic requirements.
- The panel must be mounted vertically in an upright position.
- Use four 6 mm (¼ in.) diameter screws or bolts of sufficient length to mount the panel to a sturdy vertical surface. A mounting template is provided.
- Allow clearance on the sides and bottom for service to the unit.
- Bright light can promote algae growth.
- Keep panel system electronics and enclosure away from dripping water.
- If the system is mounted outdoors, an outdoor enclosure for the whole system must be used to protect the electronics and flow cell from light, rodents, insects and dirt.



Mount out of direct sunlight.

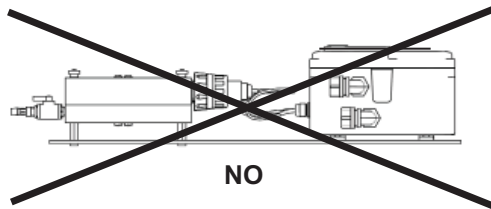

8. Wiring Input



WARNING

This panel system is wired for AC voltages that can injure or kill. Wiring should be done by qualified personnel only. Disconnect AC power before opening wiring enclosure.



Follow all local and government recommendations and methods for installation of electrical connections to and between the system and other devices.

System Input Power

- The panel system is pre-wired with an auto switching power supply that is rated for 100 to 240 VAC 50/60 Hz input.
- Wire with NEC Class I, 300 volt, 105 C wire.
- A switch or circuit breaker rated at 15 amps AC shall be included in the building installation.
- Install the circuit breaker in close proximity to the equipment and within easy reach of the operator.
- Mark the circuit breaker as the disconnecting device for the equipment.

Part # 7300-0024 shown. Actual power supply may differ from Figure 2.

100 to 240 VAC Input Wiring

- Open the electrical box by loosening the four corner screws of the front cover.
- Insert input power wiring into the pre-drilled access hole on the left side of the electrical box using the appropriate conduit adapters to maintain the Type 4X rating. (Customer may have to remove the supplied conduit connectors.)
- Install the input power wires into the proper terminals on the power supply (Figure 2). Use only 12-26 AWG copper wiring.
- Recommended torque for the terminals is 7 lb-in.

NOTE: When using alternate power supply 7300-7524:

- Use 10-24 AWG copper wiring, 105°C, torque 4.4 lb-in.

12 to 24 VDC Input Wiring Conversion

- If the power source supplied to the system will be 12 to 24 VDC instead of 100 to 240 VAC, disconnect the red and black output wires from the power supply (Figure 3) and connect your DC power source to them (Figure 4).
- Insert input power wiring into the pre-drilled access hole on the left side of the electrical box using the appropriate conduit adapters to maintain the Type 4X rating. (Customer may have to remove the supplied conduit connectors.)
- A switch or circuit breaker rated at 5 amps DC shall be included in the building installation.
- Install the circuit breaker in close proximity to the equipment and within easy reach of the operator.
- Mark the circuit breaker as the disconnecting device for the equipment.

100 to 240 VAC input
Standard AC configuration

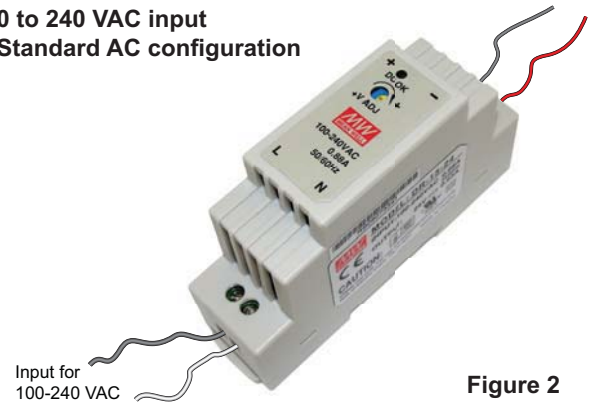

Figure 2



Figure 3

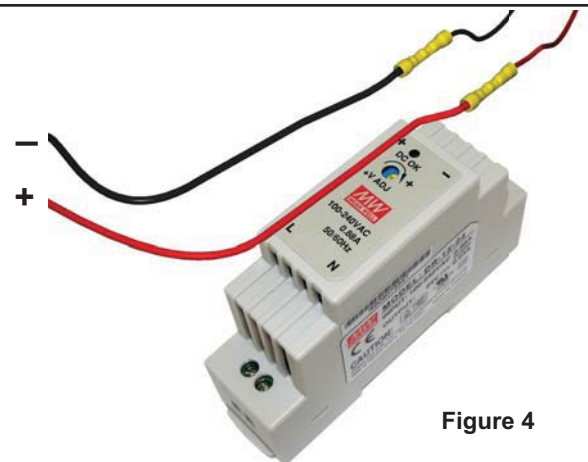

Figure 4

Power Supply Terminal Identification		
Terminal	Name	Description
V. ADJ	Voltage adjustment	Adjusts within $\pm 10\%$; turning clockwise increases output voltage
DC ON	Operation indicator	Green LED is lit when output voltage is on
+V, -V	DC output terminals	+V: Positive output terminal -V: Negative output terminal
L, N	Input terminals	Accepts a wide range of voltages and frequencies (100 to 240 VAC DC input)

8.1 Wiring Output



WARNING

This panel system is wired for AC voltages that can injure or kill. Wiring should be done by qualified personnel only. Disconnect AC power before opening wiring enclosure.

Follow all local and government recommendations and methods for installation of electrical connections to and between the system and other devices.

Output Connections

- Use the wiring enclosure terminal block for output wire connections. Do not wire directly to the transmitter.
- Recommended torque for the terminals is 7 lb-in
- Do not run 4 to 20 mA loop cables in the same conduit as the power or other high voltage wiring.
- Remove one installed jumper wire (from both of its terminals) on the terminal block in the enclosure for each loop device connected. Replace the jumper if you later remove your loop device. If only one loop device is connected, remove just one jumper wire from its two terminals.
- The panel system uses an active loop output wired to the enclosure terminal block.
- **If connecting to a PLC, use the PLC's passive input.**
- **The transmitter must have a jumper wire or loop device always connected to Loop 1.**

Wiring Label Legend	
Ground	Earth Ground. Attach 4 to 20 mA loop cable shield wire here to help eliminate possible noise.
Loop 1	4 to 20 mA Loop #1
Loop 2	4 to 20 mA Loop #2
Relay 1	Relay Output #1
NC	Relay Normally Closed when un-energized (contact)
C	Common
NO	Relay Normally Open when un-energized (no contact)
Relay 2	Relay Output #2 (terminals same as Relay #1)

Wiring a 4 to 20 mA loop device

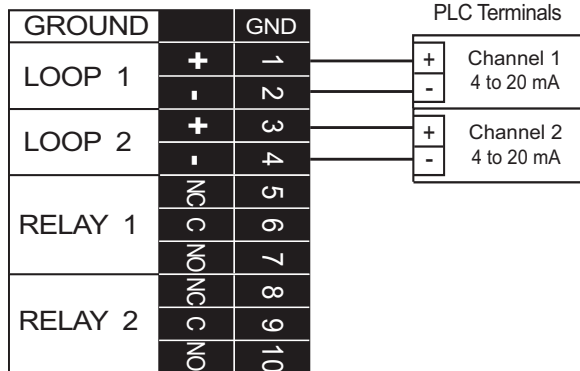
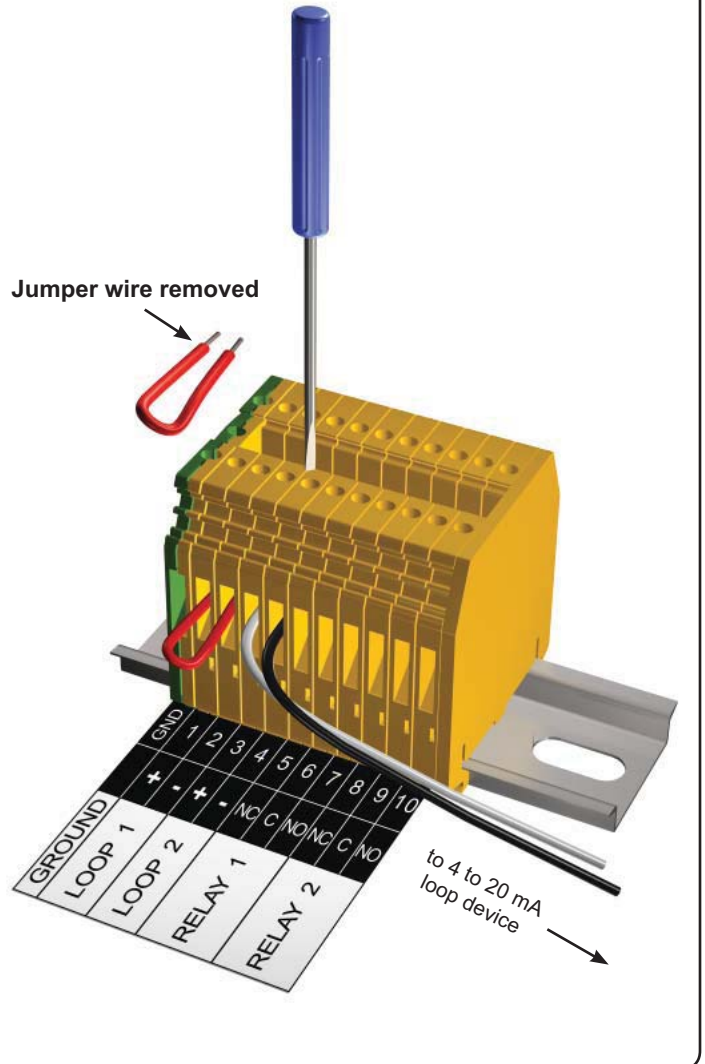

PLC dual channel connection

9. Electrical Box Wiring Schematic

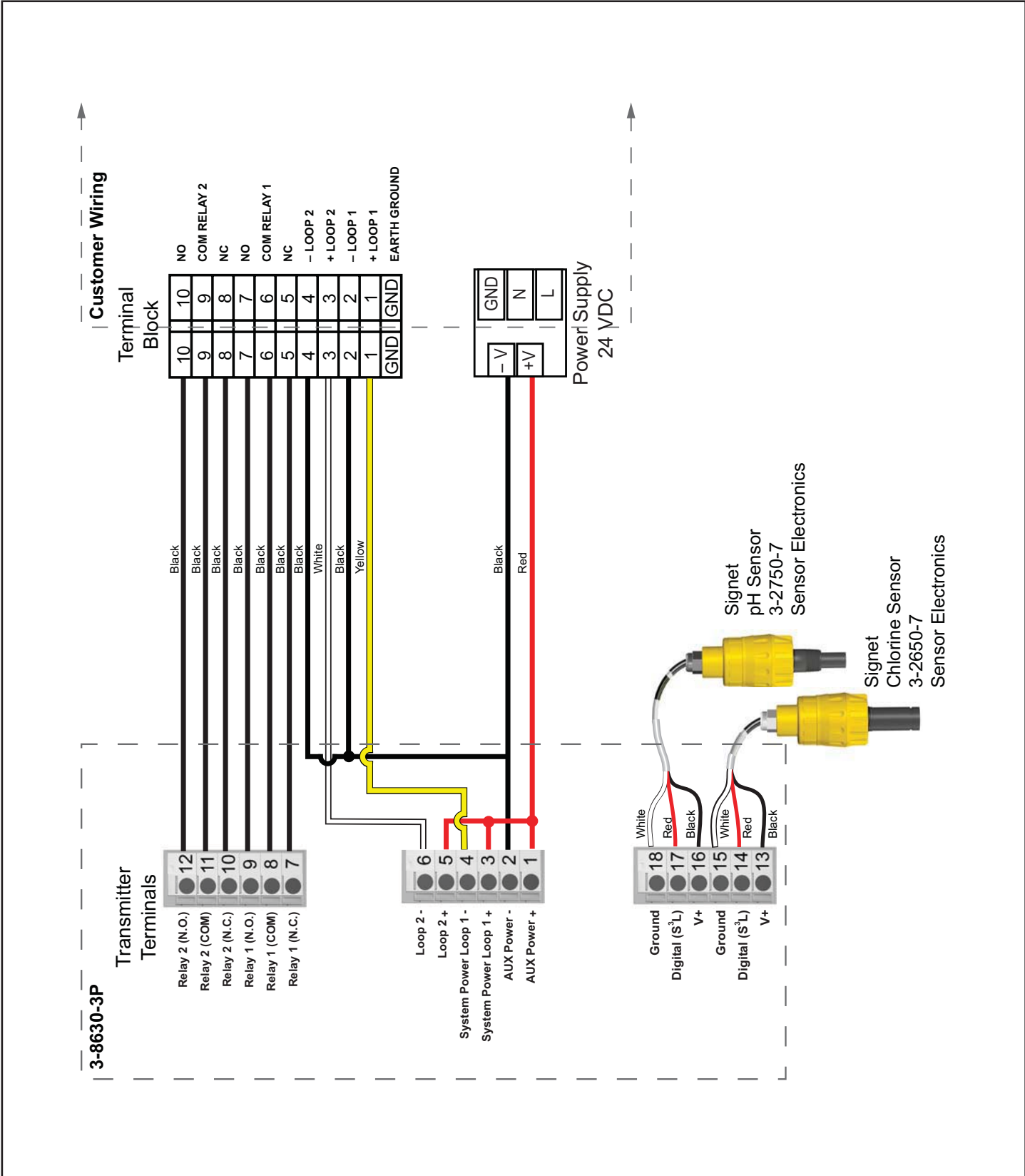

10. Sensor Installation

- Remove applicable sensor access plugs from the flow cell (pg. 2, Figure 1). Holding the 3-2750-7 or 3-2650-7 electronics inverted, open the DryLoc® connector by turning the upper locking ring ¼-turn counter-clockwise. Insert the electrode facing up. Turn the locking ring ¼-turn clockwise to lock the electronics in place. The mechanism will “click” when it is locked. Install the complete assembly into the flow cell and ensure the key on the electrode aligns with the key slot on the flow cell.

DryLoc® Connection to Sensor Electronics

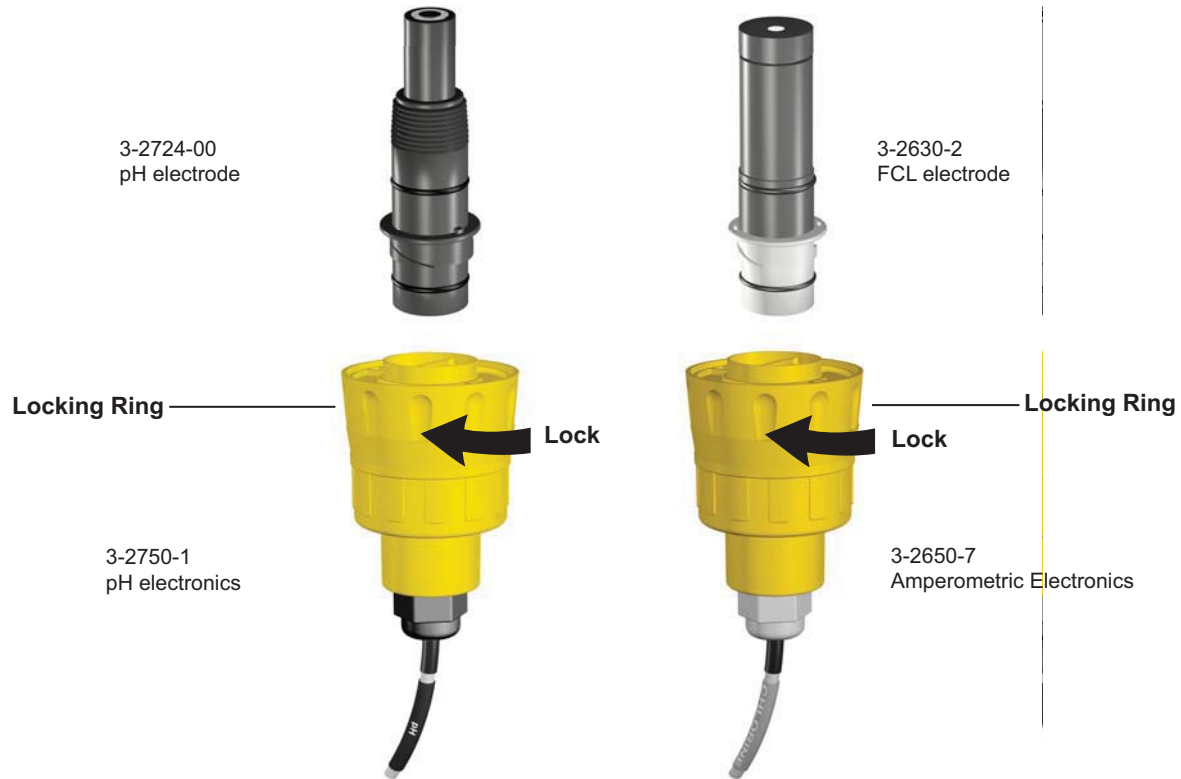

11. Tubing Connections

- Use suitable 9.5 mm (3/8 in) ID tubing that is rated for your inlet pressure. Use hose clamps.

Inlet Quick Release Connection

Press down gray plunger to release. Water flow is automatically shut off when disconnected.

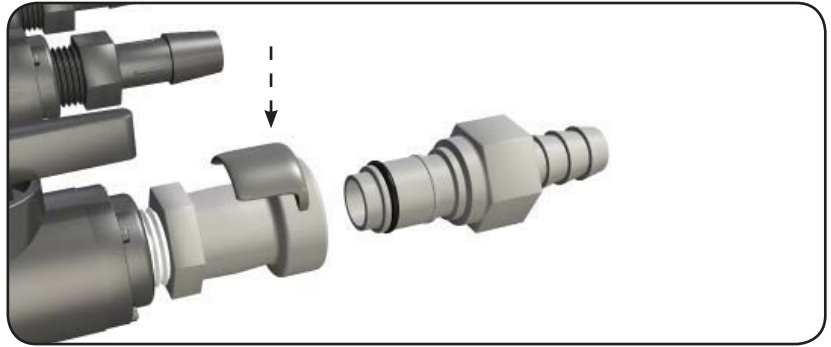

Valve position for start up and normal use.

Note: Turn off inlet valve first when stopping water flow.

- The drain tube must be positioned lower than the influent water source to allow proper flow through the flow cell. The flow cell must drain by gravity, not system pressure.

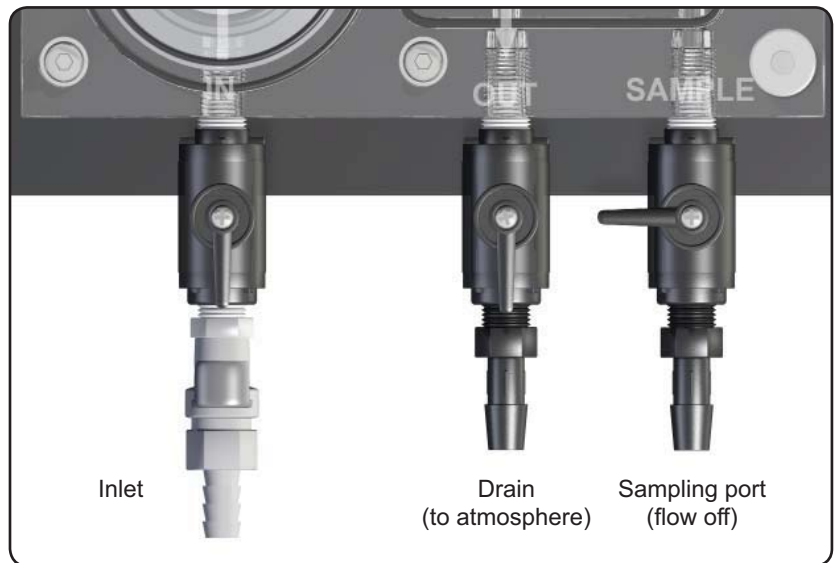

12. Water Flow

Flow Rate

The flow rate is in the proper range when the float is between the Min. and Max. markers on the flow cell. The flow range limits are 30.24 to 45.36 L/h (8 to 12 gal/h).

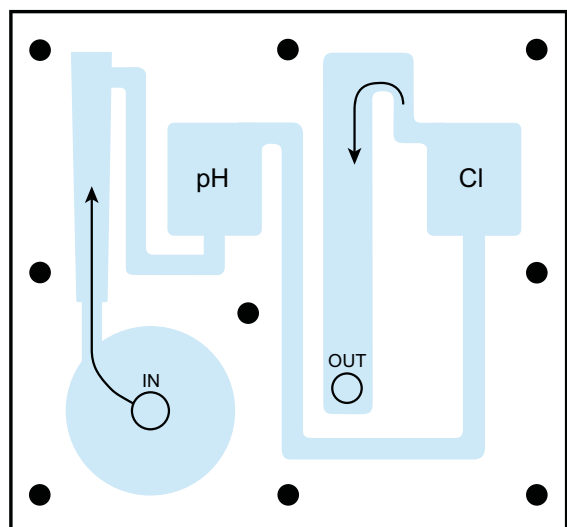
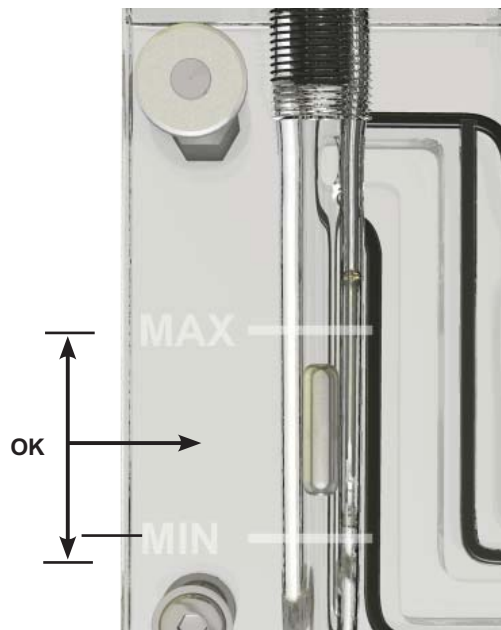

For Low Flow applications (flow less than 1 bar/15 psi), the Flow Regulator can be removed and the flow adjusted using the Flow Cell ball valve. (**NOTE:** The inlet hose barb will also need to be changed. Contact factory for details.)

Section II - 8630 Chlorine Transmitter



CAUTION!

- Remove power to unit before wiring input or output connections.
- Follow instructions carefully to avoid personal injury or damage to the transmitter.

1. The View Mode

- The View Menu is displayed during normal operation.
- To select a VIEW display, press the UP or DOWN arrow keys. The selections will scroll in a continuous loop. There are four pages to view.
- Changing the VIEW display does not interrupt system operations.
- No key code is necessary to change display selection.
- Output settings cannot be edited from the VIEW menu.
- All menus time-out after 10 minutes and return to the previous operating display.
- When editing the CALIBRATE or OPTIONS menus, the transmitter will return to the non-edit display after 10 minutes and then the VIEW menu in another 10 minutes if no activity occurs.

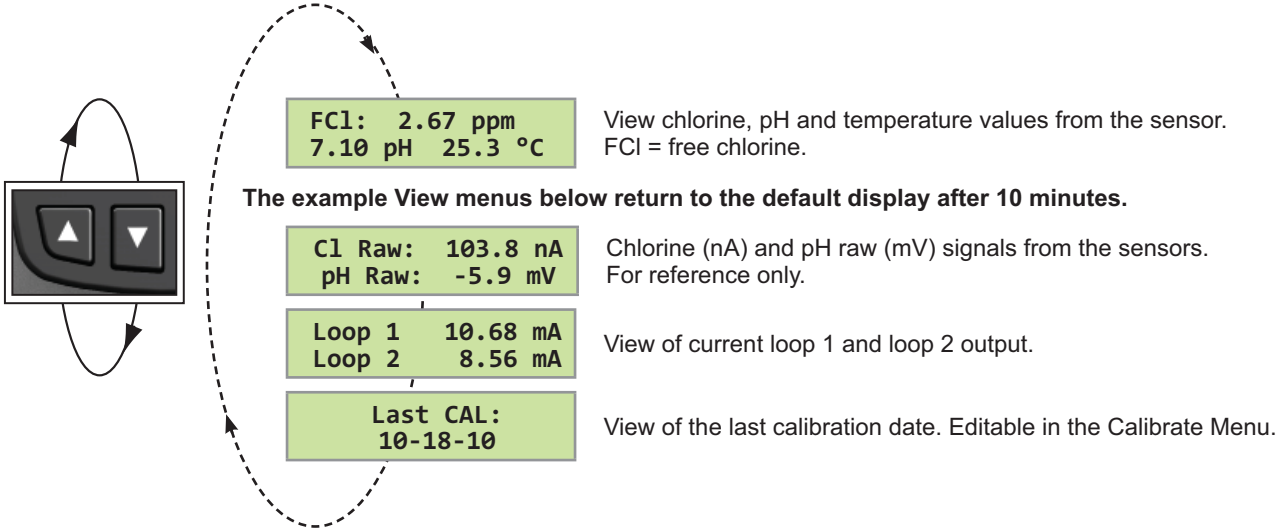

2. Transmitter Editing Procedure

- The 8630-3 has two menus the user can edit; CALIBRATE and OPTIONS.
- The CALIBRATE menu allows you to calibrate and initialize sensors, define current loops and set relay functions.
- The OPTIONS menu allows you to set sensor type, adjust and test current loops, test relays and more.

Step 1. Press and hold the ENTER key:

- 2 seconds to select the CALIBRATE menu.
- 5 seconds to select the OPTIONS menu.

Step 2. Enter the Key Code.

The Key Code is UP-UP-UP-DOWN keys in sequence.

- After entering the Key Code, the display will show the first item in the selected menu.

Step 3. Scroll the menu in a loop with the DOWN or UP arrow keys.

Step 4. Press the RIGHT ARROW key to select the menu item to be edited.

- The first display element will begin flashing.

Step 5. Press the UP or DOWN keys to edit the flashing element.

- The RIGHT ARROW key advances the flashing element.

Step 6. Press the ENTER key to save the new setting and return to Step 3.

Made an Error?

Press the UP and DOWN keys simultaneously while any element is flashing. This will recall the last saved value of the item being edited and will return you to Step 3.



Finished Editing?

Press the UP and DOWN keys simultaneously after saving the last setting to return to view menu.



2.1 Example: Calibration

Access the CALIBRATE Menu:
 The CALIBRATE and OPTIONS menus require a KEY CODE. Press and hold the ENTER key for 2 seconds to access the CALIBRATE menu.

Enter the Key Code:
 Pressing the UP, UP, UP, DOWN keys in sequence unlocks the display and the first menu item will appear. If no key is pressed for 5 minutes while the display is showing "Enter Key Code", it will return to the VIEW menu.

Scroll the Menu:
 Press the DOWN or UP keys to scroll through the Menu. Refer to pages 3 and 4 for complete listing of these items. While in this mode, pressing the UP and DOWN keys simultaneously will return the display to the VIEW menu. If no key is pressed for 10 minutes, the display will return to the VIEW menu.

Select the item to be edited:
 In this example, "Last Cal" (last calibration date) is chosen to edit. Pressing the RIGHT arrow key selects the menu item and enters the screen into edit mode.

Edit the flashing element:
 This is the edit mode. The UP or DOWN keys change the flashing element. The RIGHT arrow key advances the flashing element in a continuous loop. In this example, the "Last Cal" date was changed from 09-18-09 to 10-18-09. All output functions remain active during editing. Only the flashing element can be edited.

Press ENTER to save the new value.
 When you have set your desired value, pressing the ENTER key stores the value on the screen, making it immediately available to output functions and exits you back to Step 3.

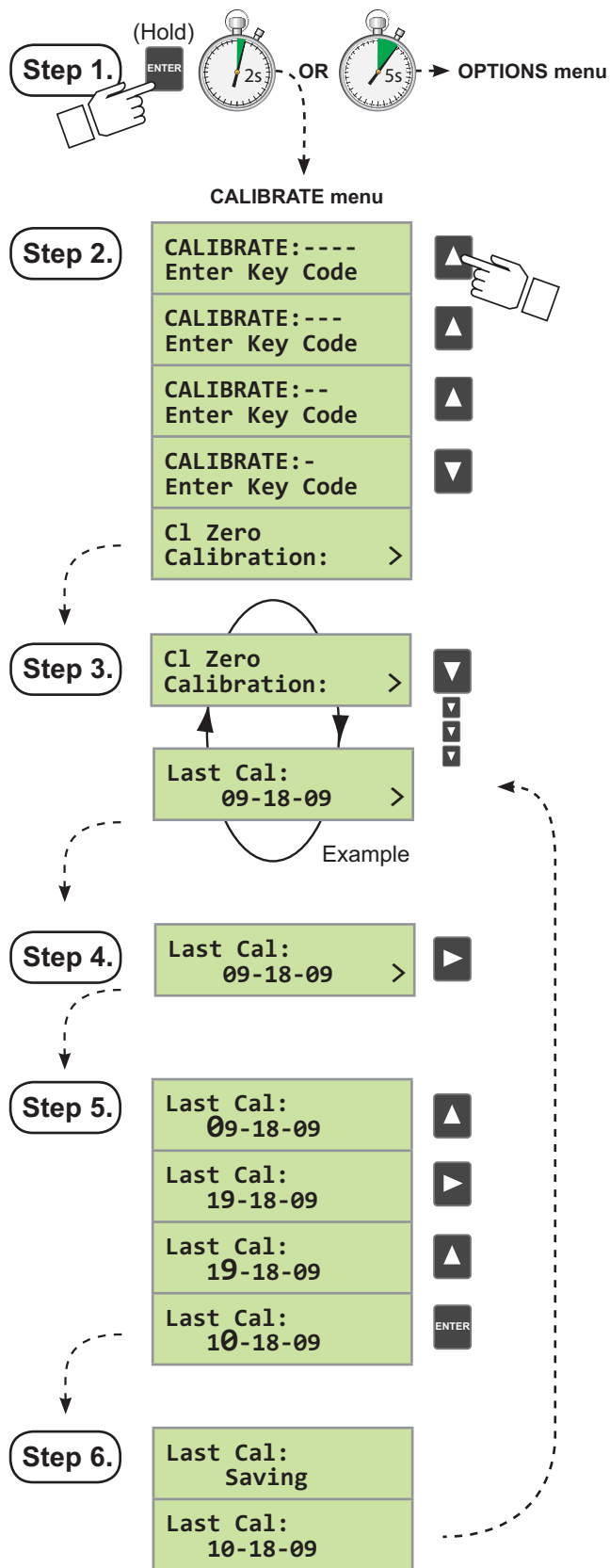

Made an Error?

Press the UP and DOWN keys simultaneously while any element is flashing. This will recall the last saved value of the item being edited and return you to Step 3.



Finished Editing?

Press the UP and DOWN keys simultaneously after saving the last setting to return to the View Menu.



3. Calibrate Menu Definitions

The menus below are displayed here in the order seen when scrolling down through the Calibrate Menu.



NOTE:

For greater accuracy it is recommended that the initial calibration of the system in the following order

1. Temperature
2. pH electrode (if optional pH sensor is purchased. If manual pH sensor is selected enter the pH value into the option menu prior to calibrating the chlorine sensor)
3. Chlorine sensor

- Although the Calibrate Menu can be navigated upwards or downwards, it is best to navigate downwards when editing Current Loop and Relay settings as previous entries can influence subsequent menus.
- Chlorine and pH calibration screens will be shown only when a valid sensor is detected.



Press the Up or Down Arrow key to scroll through the menus



Press the Right Arrow key to enter edit mode



Press the Enter key to save your settings

Calibrate Menus - Factory settings shown -	Description
Chlorine Units: ppm >	This is the first screen. Choose units of measurement of ppm or mg/l.
Cl Zero Calibration: >	When > is pressed, the “live” readings are shown. The nA value is displayed, but cannot be edited and is used for diagnostic and calibration purposes. When in Edit Mode, pressing Enter stores the displayed value as your zero reference. Example on Section 15.
Cl In Process Calibration: >	Enter process chlorine value determined from a DPD test kit here. Example on Section 15.
Reset Cl to Factory Cal: >	This menu resets Cl readings, Zero Calibration and temperature back to Factory Calibration. WARNING! User entered Cl calibration settings will be lost.
Cl Temperature Calibration: >	Enter process temperature from a reference thermometer: °C or °F. Units are set up in the Options Menu. Example on Section 15.

NOTE: The next two pH calibration screens will be shown only when a valid pH sensor is detected.

pH Standard Calibration: >	Set pH offset value. This applies a linear offset to the pH measurement. Example on Section 13.
pH Slope Calibration: >	Applies a slope to the pH measurement. The slope and standard value must be at least 2 pH units apart. Example on Section 13.
Reset pH to Factory Cal: >	Reset pH standard, slope or back to Factory Calibration. WARNING! User entered pH calibration settings will be lost.

Current Output Functions

Loop 1 Source: Chlorine >	Choose chlorine or pH for this 4 to 20 mA current loop. Example on Section 16.
Loop 1 Rng: ppm 0.00 → 5.00 >	Select the minimum and maximum values for the current loop output. Units are derived from Loop 1 Source. If the Source 1 is changed, be sure to re-edit this page.
Loop 2 Source: pH >	Choose pH or chlorine for this 4 to 20 mA current loop.
Loop 2 Rng: pH 00.0 → 14.00 >	Select the minimum and maximum values for the current loop output. Units are derived from Loop 2 Source. If Source 2 is changed, be sure to re-edit this page.

! Verify all relay settings if the Relay Source is changed.

Relay 1 Mode:
Off > Choose mode of operation: Off, Low, High, Window, or Pulse. If Off, all subsequent Relay 1 functions are inactive and not visible. Example on Section 16.3.

If Low or High Mode was chosen:

Relay 1 Source:
Chlorine > Choose chlorine or pH for Relay 1.

Relay 1 Setpnt:
0.00 ppm > In Low or Hi Mode, Relay 1 will be activated when the process reaches this value. Units of measure reflect Relay 1 Source.

Relay 1 Hys:
0.20 ppm > Relay 1 will be deactivated at Relay 1 Setpoint \pm this hysteresis setting depending on High or Low Setpoint selection.

Relay 1 Delay:
0.0 secs > Set the time delay for Relay 1 to activate after reaching the Setpoint. Range: 0 to 6400 seconds.

If Window Mode was chosen:

Relay 1 Source:
Chlorine > Choose chlorine or pH for Relay 1.

Relay1 Rng: ppm
0.00 \rightarrow 5.00 > Enter the range where Relay 1 will activate above and below this setpoint.

Relay 1 Hys:
0.20 ppm > Relay 1 will be deactivated at Range setpoints \pm this hysteresis setting.

Relay 1 Delay:
0.0 secs > Set time delay for Relay 1 to activate after reaching the setpoints set in Relay 1 Range.

If Pulse Mode was chosen:

Relay 1 Source:
Chlorine > Choose chlorine or pH for Relay 1.

Relay1 Rng: ppm
0.00 \rightarrow 5.00 > Enter the range where Relay 1 will activate above and below this setpoint.

Relay1 PlsRate:
120 pulses/min > Set the maximum pulse rate. Range: 1 to 400 pulses/min.

Relay 2 Mode:
Off > Choose Relay 2 mode of operation: Off, Low, High, Window, or Pulse. To disable this relay choose Off.

If Low or High Mode was chosen:

Relay 2 Source:
pH > Choose pH or chlorine for Relay 2. This menu screen and all subsequent Relay 2 screens below do not appear if Relay 2 Mode is set to Off.

Relay 2 Setpnt:
0.00 pH > In Low or High Mode, Relay 2 will be activated when the process reaches this value. Units of measure reflect Relay 2 Source.

Relay 2 Hys:
0.20 pH > Relay 2 will be deactivated at Relay 2 Setpoint \pm this hysteresis setting depending on High or Low Setpoint selection.

Relay 2 Delay:
0.0 secs > Set the time delay for Relay 2 to activate after reaching the Setpoint. Range: 0 to 6400 seconds.

Calibrate Menu - continued

If Window Mode was chosen:

- Relay 2 Source:**
pH >

Choose pH or chlorine for Relay 2.
- Relay 2 Rng:** ppm
0.00 → 5.00 >

Enter the range where Relay 2 will activate above and below this setpoint.
- Relay 2 Hys:**
0.20 ppm >

This relay will be deactivated at Relay 2 Range setpoints ± this hysteresis.
- Relay 2 Delay:**
0.0 secs >

Set the time delay for Relay 2 to activate after reaching the setpoints set in the Relay 2 Range.

If Pulse Mode was chosen:

- Relay 2 Source:**
pH >

Choose pH or chlorine for Relay 2.
- Relay2 Rng:** pH
0.00 → 14.0 >

Enter the range where Relay 2 will activate above and below this setpoint.
- Relay2 PlsRate:**
120 pulses/min >

Set the maximum pulse rate. Range: 1–400 pulses/min.
- Find New Sensor(s):** >

Required only when a new sensor is changed while the power is on. Choose Yes or No.
- Last Cal**
10-18-09 >

Edit the calibration date.

————— End of Calibrate Menu —————



→ **OPTIONS menu**

4. Options Menu Definitions

- ▲
▼
Press the Up or Down key to scroll through the menus
- ▶
Press the Right Arrow key to enter edit mode
- ENTER
Press the Enter key to save your settings

Options Display (Factory settings shown)	Description
<div style="border: 1px solid black; padding: 2px; display: inline-block; background-color: #e0f0e0;"> Contrast: 3 > </div>	Adjust the LCD contrast for best viewing. A setting of 1 is lower contrast, 5 is higher.
<div style="border: 1px solid black; padding: 2px; display: inline-block; background-color: #e0f0e0;"> Cl Sensor Type: Free Cl > </div>	Select the chlorine sensor: Free Cl.
<div style="border: 1px solid black; padding: 2px; display: inline-block; background-color: #e0f0e0;"> pH Input Sensor > </div>	Choose Manual or Sensor. If Sensor is chosen, the pH value from the connected pH sensor will be used. Choose Manual to enter a pH value manually when no sensor is connected.

If Manual pH input was chosen:

- Manual pH Value**
7.000 pH

Enter your pH value here if a pH sensor is not connected.
- Temp Display:**
°C >

Choose units of °C or °F.
- Averaging:**
Off >

OFF gives the fastest response to input changes. LOW = 4.5 seconds, HIGH = 9 seconds of averaged response. Increase averaging to steady the display.

Options Menu - continued

Options Display (Factory settings shown)	Description
Decimal: ***.** >	Select the decimal point for the display. Maximum of 2 decimal places.
Loop 1 Adjust: 4.00 mA >	Adjust the minimum current output for Loop 1. The display value represents the precise current output. Range: 3.80 mA to 5.00 mA.
Loop 1 Adjust: 20.00 mA >	Adjust maximum current output for Loop 1. Range: 19.00 mA to 21.00 mA.
Loop2 Adjust: 4.00 mA >	Adjust the minimum current output for Loop 2. Range: 3.80 mA to 5.00 mA.
Loop2 Adjust: 20.00 mA >	Adjust maximum current output for Loop 2. Range: 19.00 mA to 21.00 mA.
Test Loop 1: >	Press UP or DOWN keys to manually output any current value from 3.6 mA to 21.00 mA to test Loop 1 output.
Test Loop 2: >	Press UP or DOWN keys to manually output any output current value from 3.6 mA to 21.00 mA to test Loop 2 output.
Test Relay 1: >	Press UP or DOWN keys to manually toggle Relay 1 Off and On. The left LED on the front of the transmitter confirms operation.
Test Relay 2: >	Press UP or DOWN keys to manually toggle Relay 2 Off and On. The right red LED on the front of the transmitter confirms operation.
Read Sens Data: No >	If "YES" is selected the following (Read Only) screens will be shown. If "NO" then this menu ends the Options Menu.

If Yes was chosen:

Cl Sensor S/N: xxxxxxxxx	View the sensor serial number.
Cl Type & Range: 2630 xxx.x ppm	Identify the chlorine sensor type connected and its ppm range.
Zero Cal: ppm&nA xxx.xx xxxx.x	View user entered Zero Calibration data in ppm and nA.
In Proc: ppm&nA xxx.xx xxxx.x	View user In-Process Calibration value when it was entered in the Calibrate Menu.
Temp at Cal: xxxx.x °C	Temperature recorded during user In-Process Calibration.
pH at Cal: xxx.xx pH	pH value recorded during user In-Process Calibration.
Temp Offset: xxxx.x °C	Temperature offset calculated from user entered temperature calibration from Calibrate Menu.
Elapsed Time: xxxxx. hrs	Total hours of operation.
Low & High: °C -xxxx.x +xxxx.x	Lowest and highest temperatures the Cl sensor has been subjected to during operation.

————— End of Options Menu —————

5. pH Sensor Calibration

System Start-up: Step 3

If a pH sensor is part of the system, use the GF Calibration Kit 3-2700.395 (159 001 605) prior to initially installing the sensor and during its normal lifetime. If a pH sensor is not available but pH determination is necessary, measure process pH with a separate test and enter the value in the Options Menu. **Next step: Chlorine Sensor Conditioning (see section 6, page 24).**

Refer to your pH sensor manual.

The pH sensor needs to be calibrated against two different pH buffer references to calibrate the offset (standard) and slope.
Electrode offset is any deviation from 0 mV in a pH 7 buffer at 25 °C.
Slope is the ratio of mV to pH units.

- Always keep any output devices offline when calibrating.

5.1 pH Offset (Standard)

The transmitter must be powered on and the pH sensor must be connected.

- Turn off the water flow through the system, then remove the pH sensor from its flow cell.
- Using pH buffer 7.0, place enough pH buffers into a clean calibration cup, supplied with the pH calibration kit 3-2700.395 (159 001 605), to cover the tip of the electrode.
- Pour distilled water in another clean cup for rinsing the electrode between buffers
- Rinse probe, place the pH sensor in the pH 7.0 buffer and allow the mV reading to stabilize.

Example: Set pH Standard to 7.00.

- Go to the Calibrate Menu. **EXAMPLE**
- Scroll down ▼ 5 menus to the **pH Standard** menu.
- Press ► to enter Edit Mode.
- Enter the pH value of the buffer that the electrode is placed in; **7.00** in this case.
- Press the Enter button to save the setting.
- Exit to the View Menu. (▲▼)

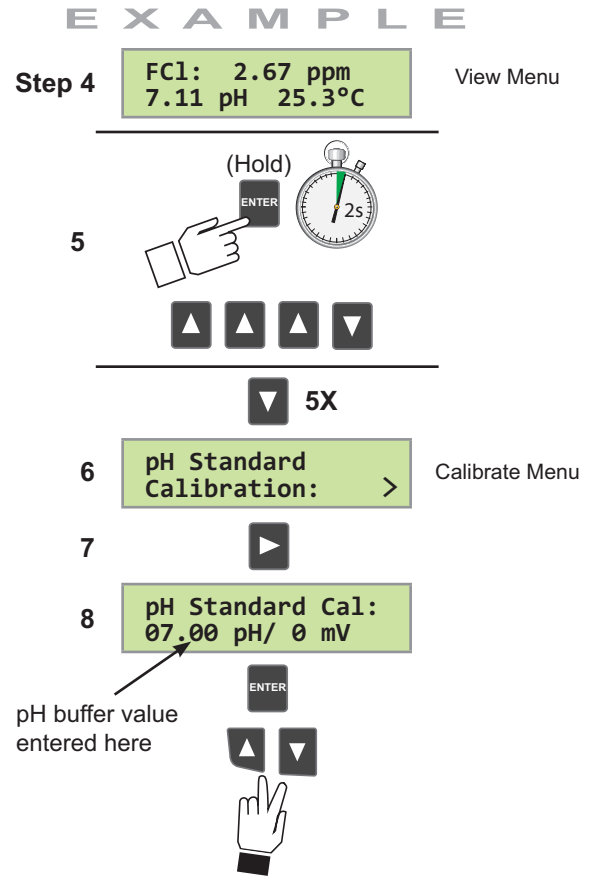

5.2 pH Slope

- Remove the pH sensor from the first buffer solution and rinse it in distilled water.
- Place the pH sensor in a different buffer solution (example: pH 4.01). The pH standard and slope must be at least 2 pH units apart.
- Note the pH and mV readings on the View Menu and allow it to stabilize.

Example: Set pH slope to 4.01.

- Scroll down ▼ 1 menus to the **pH Slope** menu. **EXAMPLE**
- Press ► to enter Edit Mode.
- Enter the pH value of the buffer that the electrode is placed in; **4.01** in this case.
- Press the Enter button to save the settings.
- Exit to the View Menu. (▲▼)
- Replace the pH sensor back into its flow cell.
- Turn on the water flow, the pH sensor calibration is complete.

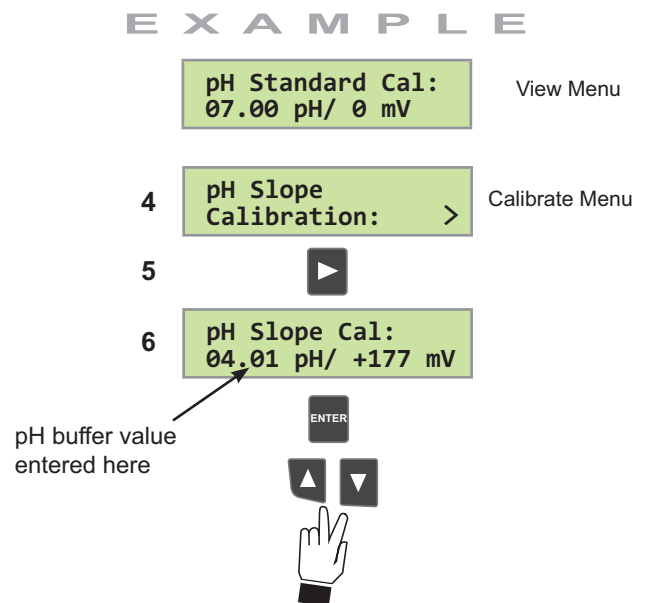

NOTE: The pH sensor will not calibrate when the mV value exceeds 50mV from the original new electrode specification.
Electrode: pH 4.01 = + 177 mV

5.3 Manual pH Compensation

If the pH of the application is stable, then the pH of the application can be entered manually and will be used to calculate the chlorine measurements.

Example: Change the pH input from Sensor to Manual and enter a pH value of 7.22.

1. Go to the Options Menu.
2. Scroll down ▼ 2 menus to the **pH Input** menu.
3. Press ► to enter Edit Mode.
4. Choose **Manual** and press Enter.
5. Scroll down ▼ 1 menu to the **Manual pH Value** menu.
6. Press ► to enter Edit Mode.
7. Enter your new process pH value: **7.22**.
8. Press the Enter button to save the setting.
9. Exit to the View Menu. (▲▼)

EXAMPLE

EXAMPLE

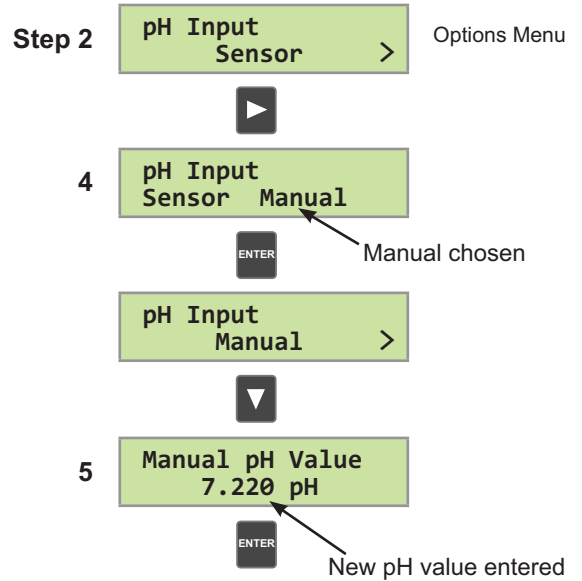

6. Chlorine Sensor Conditioning

System Start-up: Step 4

A new chlorine sensor or one that has had the electrolyte or membrane replaced must be conditioned to generate stable and accurate readings. To condition a chlorine sensor, the sensor and sensor electronics must be installed and powered and must also have water flow across the membrane:

Next step: Calibrating Chlorine (see section 7).

Chlorine Sensor Conditioning

1. Turn on and adjust water flow rate. Condition a new chlorine sensor for 4 hours. Conditioning time for a membrane cap replacement or electrolyte refill is 2 hours.
2. Keep any 4 to 20 mA devices or relay actuated output devices that connect to the transmitter offline.

7. Chlorine Sensor Calibration

System Start-up: Step 5

Chlorine sensors need to be calibrated for accuracy. After the 4 hour conditioning period, Temperature Calibration, Zero Point Calibration and In-Process Calibration needs to be performed. Any 4 to 20 mA or relay output devices should be offline.

Next step: Setting Output Settings (see section 8). ➤

7.1 Chlorine Sensor Temperature Calibration

The temperature element inside the chlorine sensor needs to be calibrated. Use a reference thermometer at the same temperature and in the same medium as the immersed sensor.

Tip: Remove the pH electrode from the flow cell and insert the reference thermometer. If no optional pH sensor is being used, remove the cell plug to insert the thermometer. Replace the plug after TC Calibration.

Example: Set the calibrated temperature to 25.3 °C.

1. Go to the Calibrate Menu. **EXAMPLE**
2. Scroll down ▼ 3 menus to the **Cl Temperature** menu.
3. Press ► to enter Edit Mode.
4. Enter the temperature reading. **Example: 25.3.**
5. Press the Enter button to save the setting.
6. Exit to the View Menu. (▲▼)

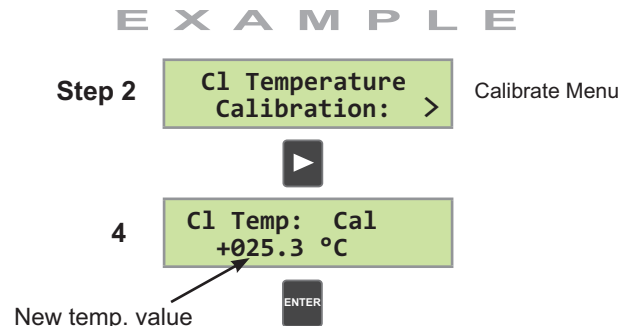

7.2 Zero Point Calibration

The chlorine sensor needs to be calibrated against two chlorine references: zero chlorine and the process chlorine. Typically the zero point calibration is very stable. Calibration must be done with every new sensor and any time a membrane cap is replaced.

1. Ensure any output devices are offline and disable relays.
2. Turn off the water flow and remove the powered chlorine sensor with the electronics still attached.
3. Place the sensor tip in distilled water.
4. Wait until the reading stabilizes, then save the calibration. Stirring the sensor in water is not necessary, but allows the signal to stabilize faster.

Example: Set the Zero Point Calibration at 1.0 nA.

5. Go to the Calibrate Menu. **EXAMPLE**
6. Scroll down ▼ one menu to the **Cl Zero** menu.
7. Press ► to enter Edit Mode. You will see flashing the live sensor readings in ppm and nA. These readings cannot be modified, but can only be saved as displayed.
8. Press the Enter button at the lowest reading to save the setting or press (▲▼) to escape without changes.
9. Exit to the View Menu. (▲▼)
10. After Zero Point Calibration is complete, replace the sensor back into the flow cell and turn the water flow back on.
11. Wait until the chlorine readings stabilize once again, then perform a chlorine In-Process Calibration.

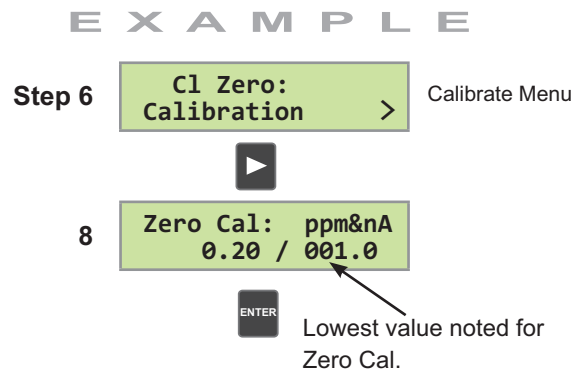

The signal level during a Zero Point Calibration must be at least 1 nA lower than the In-Process Calibration point.

7.3 In-Process Calibration

1. Take a water sample from the Sampling Port (after purging it) from a stabilized and running system.
2. Use this sample to measure the chlorine content with a colorimetric DPD test kit (not included). Refer to the DPD kit instructions on how to perform this test.
3. Record the test results.

Example: Set the Chlorine In-Process to 2.67 ppm.

- EXAMPLE**

 4. Go to the Calibrate Menu.
 5. Scroll down ▼ 2 menus to the **CI In-Process** menu.
 6. Press ► to enter Edit Mode.
 7. Enter the chlorine reading determined from the DPD test into the edit screen: **2.67 ppm**. The CI ppm is editable and must be at least 0.2 ppm.
 8. Press the Enter button to save the setting.
 9. Exit to the View Menu. (▲▼)

Calibration is complete for the chlorine sensor.

The signal level during an In-Process Calibration must be at least 1 nA higher than the previous Zero Calibration point.

EXAMPLE

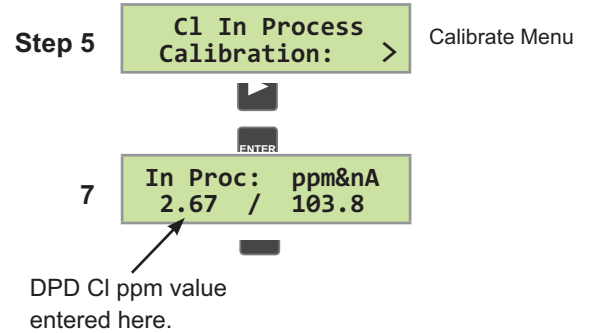

8. Output Settings - Current Loops and Relays

System Start-up: Step 6 (last step)

Configure the current loop and relay functions if applicable. The current and relay outputs can be tested in the Options Menu. This concludes the system start-up procedure.

8.1 Current Loop Settings

Current outputs are passive outputs that can be spanned in the forward and reverse direction. Example: 0 to > 5 or 5 to > 0.

Example: Set a current loop source as chlorine and the operational range to 0 to 5 ppm.

- EXAMPLE**

 1. Go to the Calibrate Menu.
 2. Scroll down ▼ to the **Loop 1 Source** menu.
 3. Press ► to enter Edit Mode.
 4. Choose either the chlorine or pH sensor as the source that will control this loop: **Chlorine**.
 5. Press the Enter button to save the setting.
 6. Scroll down ▼ 1 menu to the **Loop 1 Rng** menu.
 7. Press ► to enter Edit Mode.
 8. Select the minimum and maximum process values for the current loop output: **0 to 5 ppm**.
 9. Press the Enter button to save the setting.
 10. Exit to the View Menu. (▲▼)

EXAMPLE

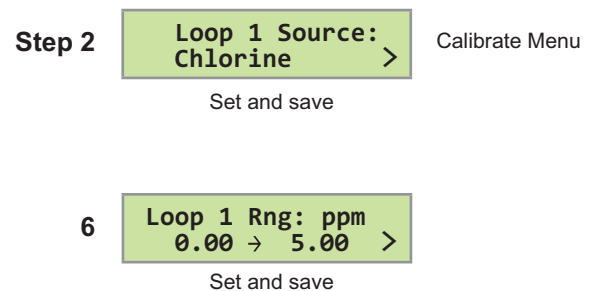

Output Settings - continued

8.2 Mechanical Relay Functions

The 8630 relays are selectable and configurable and can be used as switches that respond when the process value moves above or below a user defined setpoint. They can be used for Low Alarm, High Alarm or Proportional Pulse triggering related to the process value. Relay functions, hysteresis and time delay settings are set up in the CALIBRATE menu and can be tested in the OPTIONS menu.

◇ Low Setpoint:

Relay is activated when the measured value is less than the setpoint.

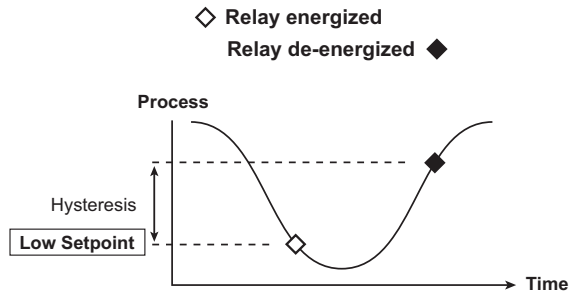

◇ High Setpoint:

Relay is activated when the measured value is higher than the setpoint.

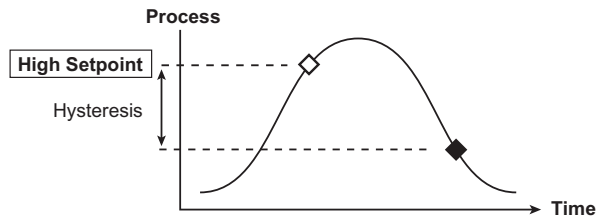

◆ Window:

Relay is off within the window of two setpoints minus the hysteresis. Relay is activated when the value is higher or lower than the high and low setpoint.

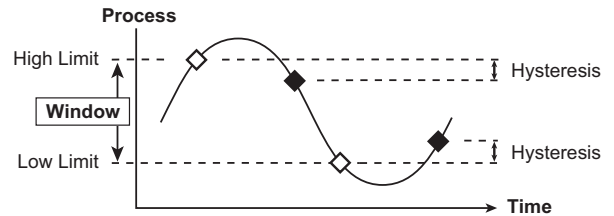

□ Pulse-frequency Operation:

The transmitter can output a pulse at the rate defined by the settings in the CALIBRATE menu and the sensor input. The maximum pulse square wave output from the relays is 400 pulses per minute. Example usage would be to control solenoid operated dosing pumps.

Example: As the process value drops below the setpoint (4 mg/l) the output will start pulsing in relation to the process value, the maximum pulse endpoint and the programmed pulses/minute. The pulse rate will increase as the process value decreases and approaches the programmed endpoint. This functionality can be used to precisely control the process.

- The output will be 0 pulses/minute when the input value is greater than 4 mg/l.
- The output will be 35 pulses/minute when the input value is 3 mg/l.
- The output will be 100 pulses/minute when the input value is 1 or less.

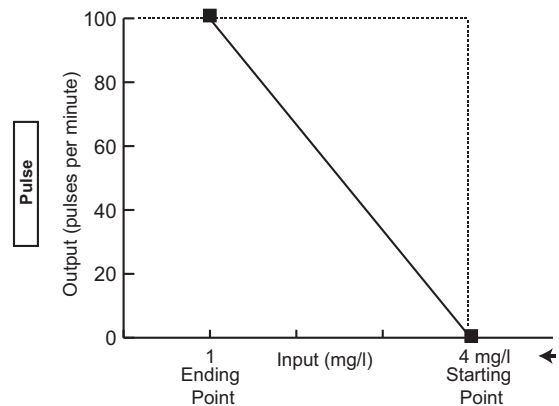

The starting point, endpoint and maximum pulse rate are selectable in the CALIBRATE menu.

8.3 Relay Settings

Example: Set a relay to trigger on at a low setpoint of 1.0 ppm with a time delay of 15 seconds and turn off at 1.30 ppm.

- Once a setting is saved it becomes immediately active.

- E X A M P L E**
1. Go to the Calibrate Menu.
 2. Scroll down ▼ to the **Relay 1 Mode** menu.
 3. Press ► to enter Edit Mode.
 4. Scroll down ▼ and choose **Low**.
 5. Press Enter.
 6. Scroll down ▼ to the **Relay 1 Source** menu. The default is Chlorine which is what we want in this example.
 7. Scroll down ▼ to the **Relay 1 Setpnt** menu.
 8. Press ► to enter Edit Mode.
 9. Set the ppm value to trigger the relay: **1.00 ppm**.
 10. Press Enter.
 11. Scroll down ▼ to the **Relay 1 Hys** menu.
 12. Press ► to enter Edit Mode.
 13. Set the hysteresis (dead zone) for this relay. This affects the turn off only: **0.3 ppm**.
 14. Press Enter.
 15. Scroll down ▼ to the **Relay 1 Delay** menu.
 16. Press ► to enter Edit Mode.
 17. Set the turn-on delay in seconds for the relay: **15 secs**.
 18. Press Enter.
 19. Exit to View Mode. (▲▼)

- Relay function can be tested in the Options Menu.

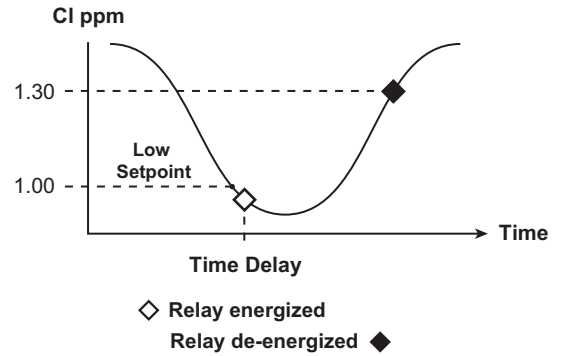

E X A M P L E

- Step 4** Relay 1 Mode:
Low > Calibrate Menu
Set and save
- 6** Relay 1 Source:
Chlorine >
Set and save
- 9** Relay 1 Setpnt:
1.00 ppm >
Set and save
- 13** Relay 1 Hys:
0.30 ppm >
Set and save
- 17** Relay 1 Delay:
15.0 secs >
Set and save

Section III - Signet 2650-7 Chlorine and 2750-7 pH DryLoc® Amperometric Electronics



CAUTION!

- Remove power before wiring.
- Follow instructions carefully to avoid personal injury or damage to the electronics.



1. Installation

- Remove applicable sensor access plugs from the flow cell (Section I, Figure 1). Holding the 3-2650-7 or 3-2750-7 electronics inverted open the DryLoc® connector by turning the upper locking ring ¼-turn counter-clockwise, insert the electrode facing up. Turn the locking ring ¼-turn clockwise to lock the electronics in place. The mechanism will “click” when it is locked. Install the complete assembly into the flow cell and insure the key on the electrode aligns with the key slot on the flow cell.



Avoid skin or eye contact with electrolyte solution. Wear rubber gloves and goggles.

Material Safety Data Sheets (MSDS) are available online at www.gfsignet.com.



Do Not Use Lubricant or Sealing Tape on Threads. Do Not Overtighten. Do Not Use Tools.

- **Free chlorine** electrodes are pre-filled with electrolyte solution. Simply pull off the protective boot from the end of the electrode and install the electrode into the flow cell fitting.

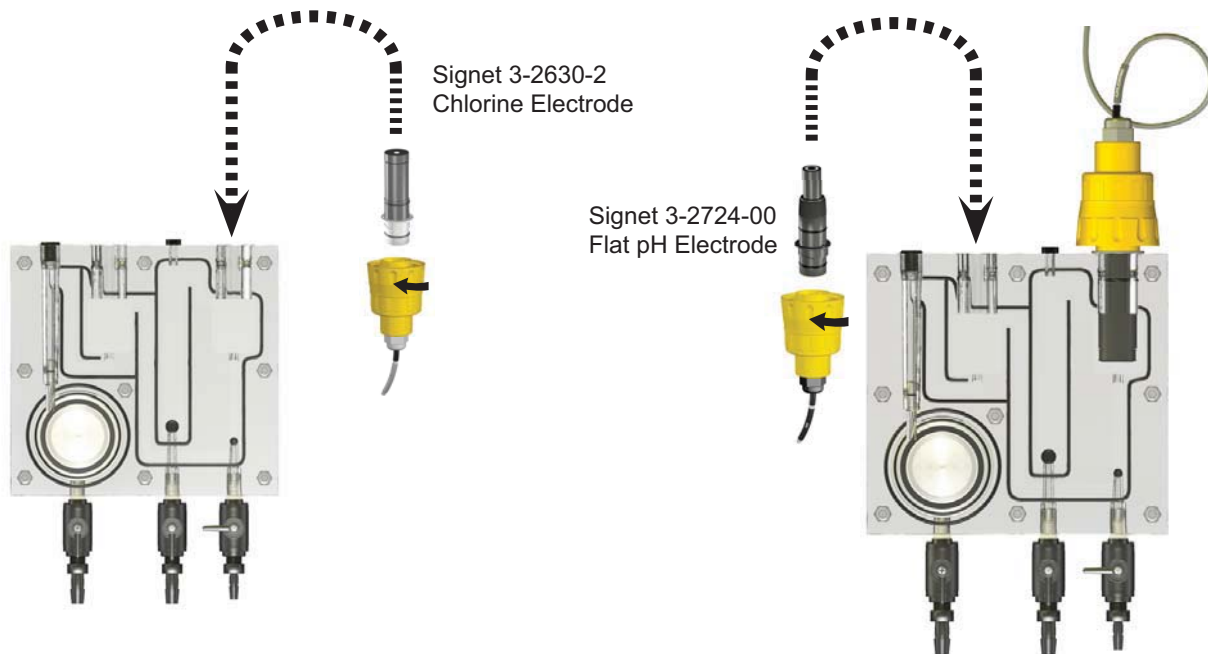

2. Wiring

Wiring to the Signet 8630 Chlorine Transmitter

The electronics are pre-wired from the factory to the transmitter. Refer to the following schematics when replacing the electronics.

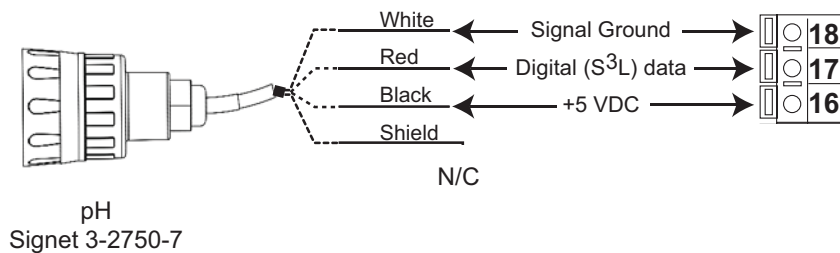

Chlorine Digital (S³L) Wiring

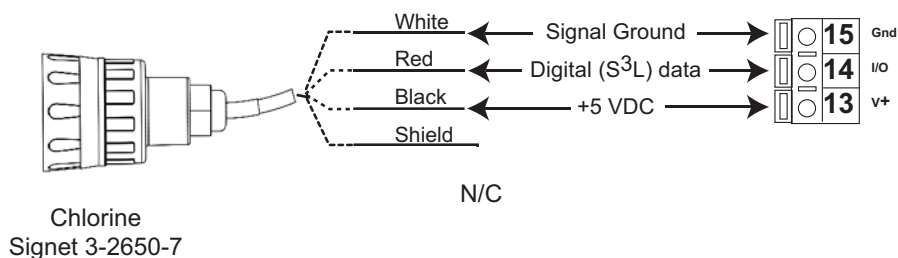

- Refer to the wiring diagram above to connect the 2650 cable to the terminals on the 8630 Chlorine Transmitter.
- For calibration and configuration please refer to the 8630 Signet Chlorine Transmitter (section II).

Section IV - Signet 2630 Amperometric Chlorine Electrode



CAUTION!

- 1 Follow instructions carefully to avoid personal injury or damage to electrode.
2. Prior to installation or removal:
 - a. Disconnect flow through system.
 - b. Drain below sensor level.
3. Confirm chemical compatibility before use.
4. Do not alter product construction.



Lubricate O-rings with a non-petroleum based, viscous lubricant (grease) compatible with the system.

1. Operation

Mfr. Part No.	Code	Chlorine Range	Chlorine Type
3-2630-2	159 001 662	0 to 5 ppm (mg/l)	Free chlorine

Electrode Range: The electrode must match the type and range of chlorine concentration to be measured.

Flow Rate:

The electrode must have a stable and constant flow of water past its membrane for accurate measurement.

When the sensor is installed in the Flow Cell Block 3-4630.392 (159 001 690), the flow rate range is controlled by the internal flow regulator and the flow rate is reduced to 30.24 to 45.36 LPH (8 to 12 US g/h).

Sensor Conditioning: 4 hours

A new electrode requires conditioning of 4 hours with the electrode powered on and water flowing past the membrane to generate a stable reading.

Subsequent start-ups can require an electrode conditioning of up to two hours.



The electrode should not be used in water containing surfactants, oils, organic chlorine or stabilizers such as cyanuric acid.



The maximum allowable operating pressure must be less than 1 bar (15 psi). Higher pressures will damage the electrode.

2. Overview

Chlorine in Water

Various forms of chlorine are used to disinfect water. Each form of chlorine has benefits and limitations which help determine the specific application. The predominant categories used in disinfection are Free Chlorine, Total Chlorine and Chlorine Dioxide. Free Chlorine is the sum of chlorine gas (Cl_2), hypochlorous acid (HOCl) and hypochlorite (OCl^-). Above pH 4.0 all of the molecular chlorine is converted to HOCl and OCl^- . Hypochlorous acid is a more potent disinfectant than hypochlorite and exists in a pH dependent equilibrium as shown in Figure 1.

Free chlorine also combines with naturally occurring or human-introduced nitrogen compounds in the water to form chloramines, also known as combined chlorine. Treatment operators introduce ammonia into the water to form monochloramine (NH_2Cl), dichloramine (NHCl_2) and trichloramine (NCl_3). Chloramines are a less effective disinfectant but have a longer residence time than the free chlorine species. GF Signet sensors cannot detect or monitor chloramines. Total chlorine is the sum of free chlorine (Cl_2 , HOCl and OCl^-) and combined chlorine (NH_2Cl , NHCl_2 , NCl_3).

Chlorine Measurement by Amperometric Sensors

Signet chlorine sensors are membrane-covered amperometric 2-electrode sensors. A gold or platinum cathode acts as the working electrode with a silver halide acting as the counter electrode. Depending on the species to be analyzed, a polarization voltage is applied between the two electrodes. When placed into service, the chlorine species of interest diffuses across the membrane and is reduced at the cathode surface. For the case of total chlorine, the analyte reacts with the fill solution to produce an intermediate, which is subsequently reduced at the cathode surface. At the same time, the silver anode is oxidized to form a silver halide. The current generated at the cathode is proportional to the rate of diffusion through the membrane and the concentration of chlorine in the sample. The current from the cathode to the anode is conditioned, digitized and transmitted by the associated electronics.

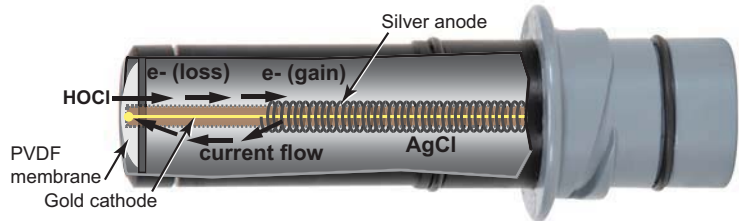

pH Compensation for Free Chlorine

Amperometric free chlorine sensors measure only hypochlorous acid. As noted in the text above and in Figure 1, the ratio of hypochlorous acid and hypochlorite is pH dependent. In many applications the process pH is relatively stable and no correction is needed. However, where the pH of the water changes significantly, accurate free chlorine measurement requires pH compensation. With the addition of a pH sensor, the Signet 8630 transmitter will automatically compensate the free chlorine reading for changes in pH.

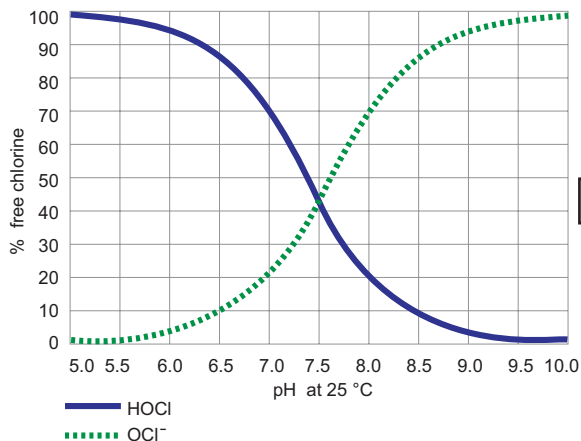

Figure 1

Automatic pH Compensation and Free Chlorine

In many applications, the process pH does not significantly fluctuate and only a sensor and instrument is necessary for accurate chlorine measurement. It is when the pH varies that free chlorine concentration can not accurately be determined without the use of automatic pH compensation.

The addition of the Signet 3-2724-00 (159 001 545) pH electrode along with its 3-2750-7 (159 001 671) preamplifier to the system makes pH compensation extremely easy and automatic even with wide fluctuations or high pH.

See Figure 2 for pH variation recommendations.

Example:

If the pH nominal value is 7.5 and the pH variation is ± 0.2 then automatic pH compensation is recommended.

If the pH nominal value is 7.0 and the pH variation is ± 0.2 then automatic pH compensation is not required.

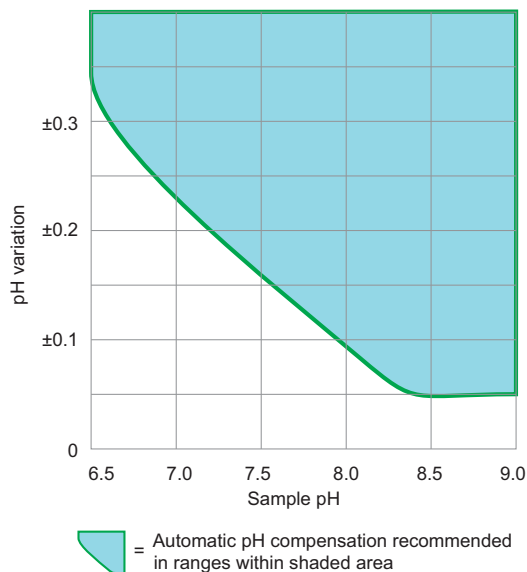

Figure 2

3. Calibration

A new chlorine electrode or one that has had the membrane cap changed must be calibrated. Refer to section II, 8630 Transmitter information on calibration of the chlorine sensor. A diethyl-p-phenylenediamine (DPD) colorimeter test kit (not included) is required for sensor calibration. A sample is taken and analyzed with the DPD test kit, then this value is entered into the Signet 8630 transmitter.

- Calibrate after a membrane cap change (requires 4 hour stabilization time).
- Calibrate after the internal electrolyte is replaced (requires 2 hour stabilization time).
- Check calibration one day after sensor is placed in service.
- Check calibration weekly to monthly depending on process requirements.

The sensor membrane and internal electrolyte solution must be replaced over the life of the electrode. GF Signet recommends that the internal electrolyte and membrane be replaced every 3 to 6 months to maintain accurate chlorine measurements. Actual interval between maintenance of the sensor will be dependant on the actual applications, chlorine level and contaminants in the water.

A weekly inspection is recommended. If the membrane becomes dirty, rinse with fresh water only. Do not use brushes, detergents or solvents. If a fresh water rinse does not clean the membrane, it will need to be replaced. Keep spare membrane caps available. Membrane caps carry no warranty.

Section V - Signet 2724 DryLoc pH Electrode



Lubricate O-rings with a non-petroleum based, viscous lubricant (grease) compatible with the system.

CAUTION!



1. Use appropriate eye, face, hand, body and/or respiratory protection when using chemicals or solvents.
2. Prior to installation or removal:
 - a. Depressurize and vent system.
 - b. Drain below sensor level.
3. Confirm chemical compatibility before use.
4. Do not alter product construction.

1. Dimensions

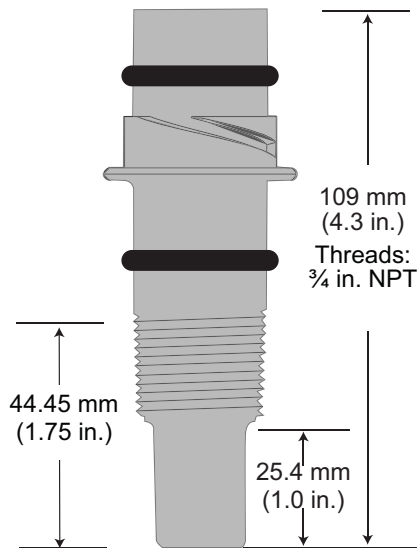

2.1 Operating Temperature and Pressure Specifications

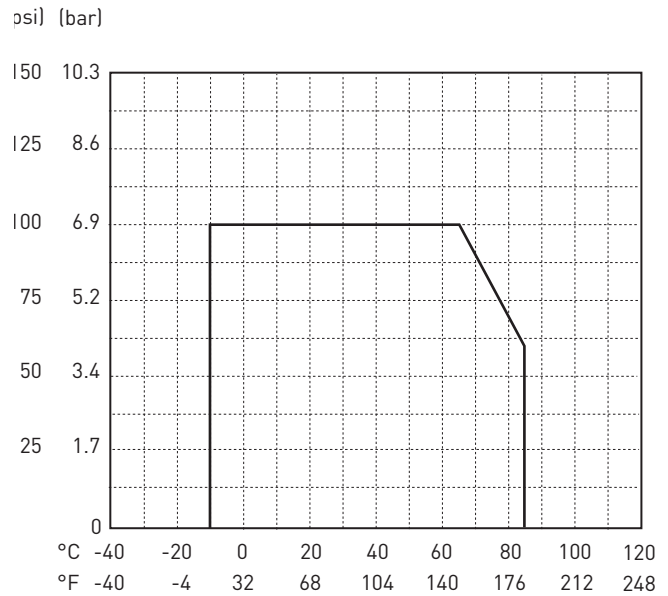

Max. Temperature/Pressure Rating

Operating Temperature Range*:

-10 °C to 85 °C (14 to 185 °F)

Operating Pressure Range:

-10 to 65 °C (14 to 149 °F),

0 to 6.9 bar (0 to 100 psi)

65 to 85 °C (149 to 185 °F),

linearity derated 6.9 to 4.0 bar (100 to 58 psi)

Warning:

3-2724-00 is the only recommended electrode to be used in the Chlorine Analyzer System.

1.1 Removing the electrode from In-line installations



The use of this product assumes that operators are trained and are familiar with this type of device. They should be knowledgeable of the potential risks associated with pressurized piping systems. Operators MUST follow all necessary safety procedures.

In-line removal Instructions:

1. Depressurize and vent the piping system.
2. Drain the system to below sensor level.
3. Wear safety goggles or face shield during removal.
Use all appropriate eye, face, hand, body and/or respiratory protection when working with chemicals or solvents.
4. Place a Lockout tag on the pipe when the sensor is removed for maintenance to prevent accidental opening and exposure to potentially hazardous chemicals.

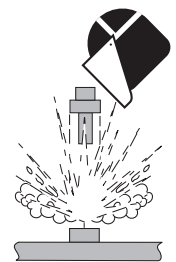

2. pH System Calibration

2.1 pH Calibration Procedure

1. Rinse the sensor off in the rinse water cup. Gentle pat dry with a soft, dry cloth or tissue. **Warning: Do not let the rinse water drip into the buffer solution; this will dilute the solution and may lead to offset buffer values.**
2. Gently place the pH sensor in the first buffer solution (pH 7). Wait until the output from the sensor is stable on the instrument display.
3. Follow the instrument's instructions regarding buffer recognition.
4. Rinse the sensor with water. **Warning: Do not let the rinse water drip into the buffer solution; this will dilute the solution and may lead to offset buffer values.**
5. Dry the sensor gently by patting it with a dry, clean cloth or tissue.
6. Place the sensor in a cup containing the second buffer solution (pH 4 or pH 10). The second solution used will depend on the typical pH value of the application.
 - If the process value is below pH 7, then use a pH 4 buffer solution.
 - Sometimes pH 10 buffer solution is used when the typical process value is above 7 pH, however, pH 4 buffer is sufficient if pH 10 buffer is not available.
7. Wait until the output from the sensor is stable.
8. Follow the instructions in the instrument manual regarding buffer recognition.
9. Rinse the sensor with water. **Warning: Do not let the rinse water drip into the buffer solution; this will dilute the solution and may cause offset buffer values.**
10. Dry the sensor gently by patting it with a dry, clean cloth or tissue.
11. If the calibration was successful, put the sensor back on-line. If it was not successful, clean the sensor and recalibrate. If the sensor cannot be calibrated, the electrode may need to be replaced.

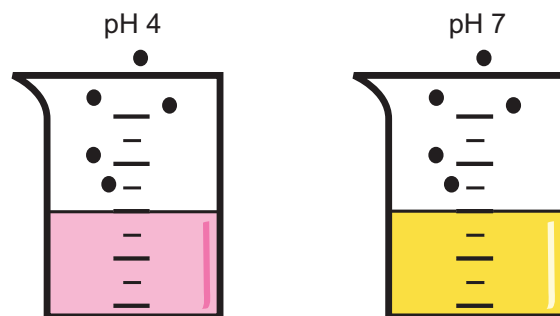

2.3 Calibration Tips:

1. The pH solutions can be used for calibrating more than one sensor within a day. However, the solutions must remain free of debris and must not be diluted by rinse water from previous calibrations.

Note: Use fresh buffer solutions for best results.

2. Tap or deionized water may be used to rinse the electrodes between each buffer solution.
3. Calibration solutions change value with varying temperature. Sensors will not calibrate properly if the sensor is not at ambient temperature. Take note of all temperature variations of the sensors and the calibration solutions.
4. Do not pour used buffer solutions back into the bottle; dilute with plenty of water and flush them down the drain.
5. Store electrodes in pH 4 buffer when not in use.
6. Calibrate sensors on a regular basis.
7. If the pH sensor does not calibrate within acceptable limits, clean the electrode and calibrate again. If the sensor continues to calibrate outside of acceptable limits, the electrode is spent and must be disposed.
8. Acceptable pH ranges during calibration are as follows:

pH 7: High: 7.8 pH = -50 mV Low: 6.2pH = 50 mV

pH 4: High: 4.8 = 227 mV Low: 3.2 = 127mV

pH 10: High: 10.8 = -227 mV Low: 9.2 = -127 mV

2.3 Electrochemical pH vs. mV Ratio

- The mV output from the electrode is created by the interaction of the electrode and the fluid. The electrode contains a gel that depletes over time, so the instrument must be readjusted periodically to maintain system accuracy. The need for recalibration varies with each application, but the life of the electrode is usually consistent.
- Keep a maintenance log to establish a depletion trend in new systems.
- The mV calibration is a two-point procedure. Signet offers pH buffer solutions prepared specifically for this purpose.
- pH buffer solutions can be used for calibrating more than one sensor within a day provided that the solutions are protected from debris and are not diluted by rinse water from the calibration procedure.
- Use clean water to rinse buffer solutions from the electrode.
- Dispose of all buffer solutions at the end of the day.
- If the pH sensor will not calibrate within acceptable limits, clean the electrode and recalibrate. If the calibration results remain outside of acceptable limits, the sensor is depleted and must be discarded.
- Follow the guidelines of local waste disposal regulations when discarding buffer solutions and spent electrodes.

Theoretical mV Values @ 25 °C	
pH	mV
2	+295.8 mV
3	+236.64 mV
4	+177.48 mV
5	+118.32 mV
6	+59.16 mV
7	0 mV
8	-59.16 mV
9	-118.32 mV
10	-177.48 mV
11	-236.64 mV
12	-295.8 mV

Table 2:

Electrode slope is the ratio of mV to pH units. At 25 °C the theoretical slope is 59.16 mV per pH.

3. Electrode Data Code

The electrode date code indicates the manufacturing date of the electrode. Electrodes should be put into service as soon as possible and should not remain in the box for more than two years. Over time, the storage solution (found in the "boot" covering the electrode tip) will evaporate or leak, allowing the delicate sensing tip and reference junction dry.

To rehydrate a dry electrode, soak it in pH 4 buffer for 24 to 48 hours. Electrodes more than 2 years old may still be functional, but will take longer to rehydrate. Restoration may not be effective for severely dehydrated electrodes.

First Letter = Month
N = January
M = February
L = March
K = April
J = May
H = June
G = July
F = August
E = September
D = October
C = November
B = December

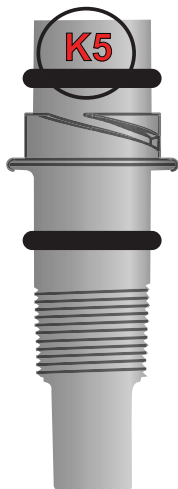

Second Numeral = Year
5 = 2010
6 = 2011
7 = 2012
8 = 2013
9 = 2014
0 = 2015
1 = 2016
2 = 2017
3 = 2018
4 = 2019

Example: K5 = manufactured in April 2010

Section VI - Appendix

1. Maintenance - 4630 Chlorine Analyzer System

Sensor Removal

Caution!

Over time, a sensor can get tight in the flow cell fitting. When removing the sensor, avoid hitting the sensor electronics into the bottom of the wiring enclosure if the sensor suddenly releases.

While holding the flow cell, grasp the yellow electronics as a whole unit and carefully pull upwards, gently rocking back and forth if necessary. Once the sensor is loose, disengage the electronics, then remove the sensor. **TIP:** A tool can be used to carefully pry the sensor electronics up and out if it is difficult to remove.

 **Take care not to damage the components.**

Under certain conditions, a dirty flow cell and filter can create a chlorine demand which could lower the chlorine concentration in the water flowing past the chlorine sensor. Because of this, it is recommended to clean the filter and flow cell on a regular basis. The frequency of necessary cleaning will depend on the application in which the system is being used and the level of accuracy required.

1.1 Cleaning

 Service the flow cell on a clean, dirt free surface to avoid scratches or damage to the flow cell.

Step 1. Keep the system powered on.

Step 2. Disable the relays and any output loops.

Step 3. Turn off the water flow.

Step 4. Remove the sensors from the flow cell.

NOTE: It is not necessary to remove the electronics from the sensor.

Step 5. Install the vinyl caps on to the sensor tips or place the tips of the removed sensors in a cup of sample water for temporary storage while cleaning the flow cell.

 **Keep the sensor tips wet and the sensors energized.**

Step 6. Remove the flow cell from the panel by removing the knurled nuts (Figure 1).

Step 7. Remove the remaining hardware from the flow cell. (Figure 2).

NOTE: It is recommended that an anti-seizing compound appropriate for the application be used during the reassembling of the flow cell.



- Wash the surfaces with water or soapy water only.
- Use gentle, liquid dish washing soap if necessary.
- Do not use commercial glass cleaning fluids.
- Use a soft, lint-free cloth.

Servicing the Flow Regulator and Filter

Remove filter screen to clean. If the filter is not desired, it may be removed from the system. 

If your inlet pressure is less than 1 bar (15 psi), remove the flow regulator and quick disconnect inlet connector.



WARNING: Do not disassemble the flow regulator. There are no user serviceable parts inside.

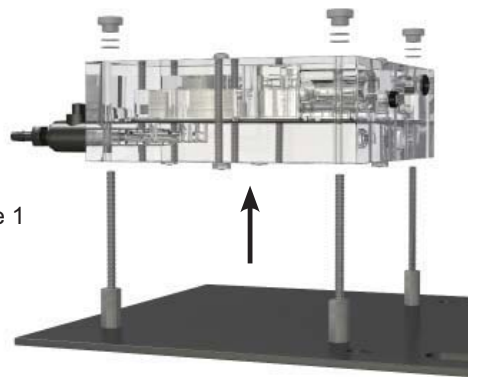

Figure 1

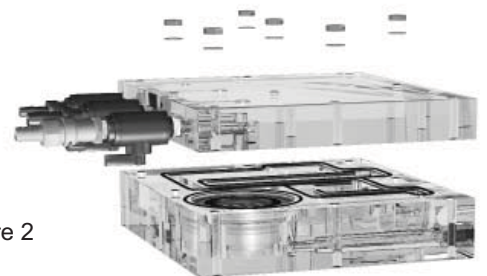

Figure 2



Flow Regulator

1.2 O-Ring Installation



CAUTION!

The 3-4630-391 O-ring kit comes complete with two O-rings (5 and 6) and a single cord of material that must be cut and fitted into the O-ring groove of the flow cell (1 and 4).

- The sealing of the flow cell is accomplished by four cut O-ring segments and two round O-rings sealing the flow regulator. Refer to the illustration below for special O-ring fitting instructions. Butt all O-ring joints together so there is no gap.
- Remove the O-rings during flow cell disassembly. Both the O-rings and all sealing grooves should be examined for cleanliness.
- Wipe all surfaces carefully with a soft, lint-free cloth to ensure good sealing.
- The cross section of the O-rings should be round and smooth. If they are flattened, their ability to seal is reduced.
- Do not use liquid or paste sealant.

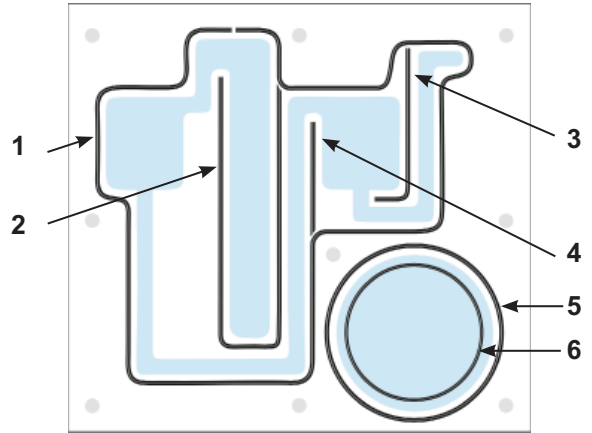

Individual O-rings shown.
Butt all segment joints together in final assembly.



Do not scratch the sealing surfaces of the flow cell block. Scratches to the sealing surfaces can cause irreparable leaks.



New O-ring
cross section



Old flattened O-ring
cross section
(Replace)

Fit all O-ring joints so there is no gap in final assembly.

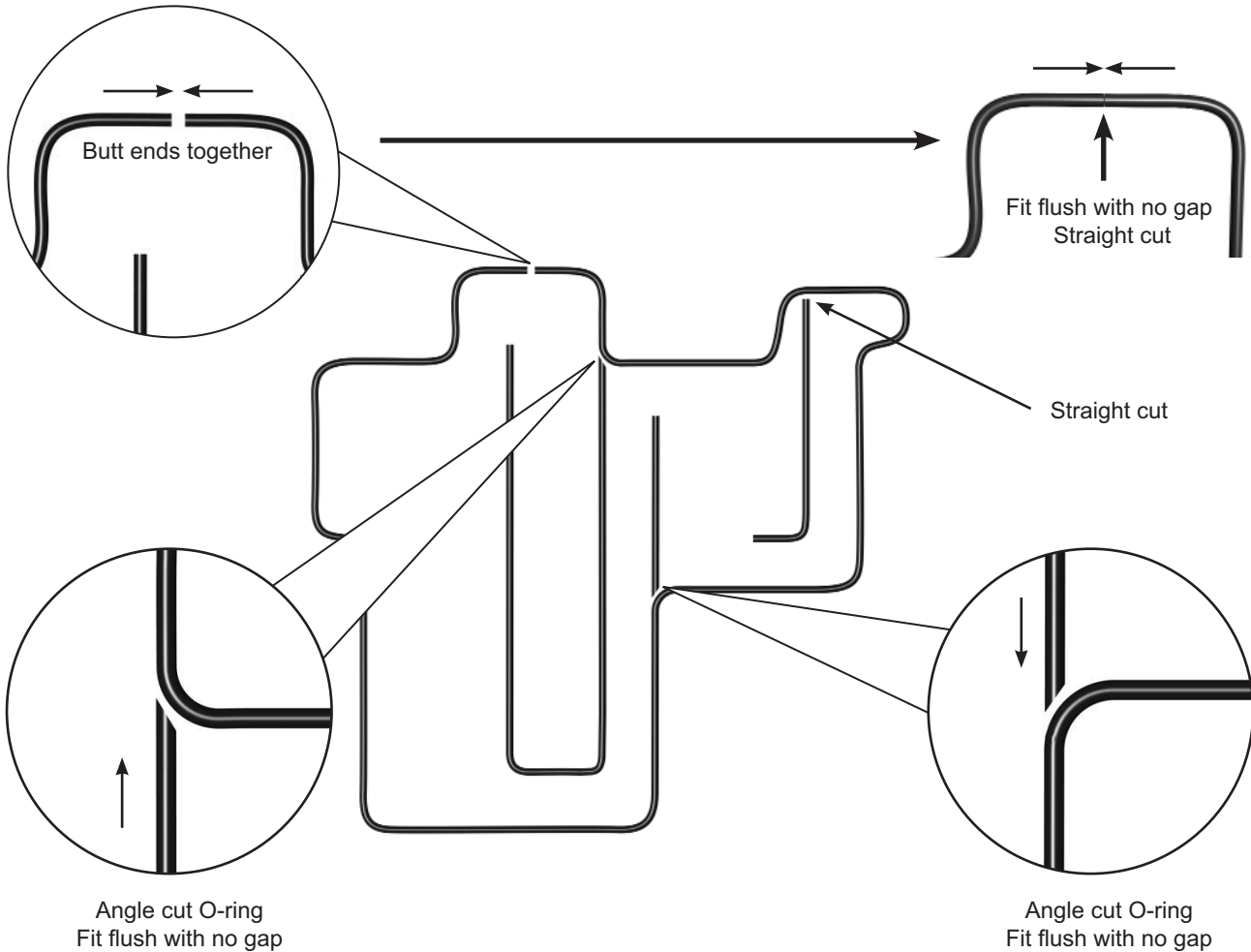

1.3 Flow Cell Assembly

WARNING!



Do not over tighten flow cell bolts. Maximum torque is 8.1 Nm (72 Lb-In).
Over tightening the bolts can damage the flow cell.
Do not over tighten the bolts in an attempt to stop a leak.

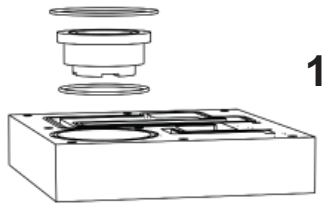

1

Install the assembled pressure regulator and the two round O-rings into the flow cell.

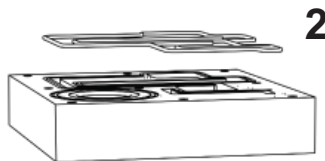

2

Install the four O-ring segments.



3

Insert the center bolt into the block.

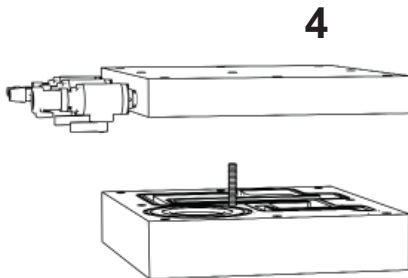

4

Align and place the back block onto to flow cell. Check to be sure that the O-rings are seated correctly.

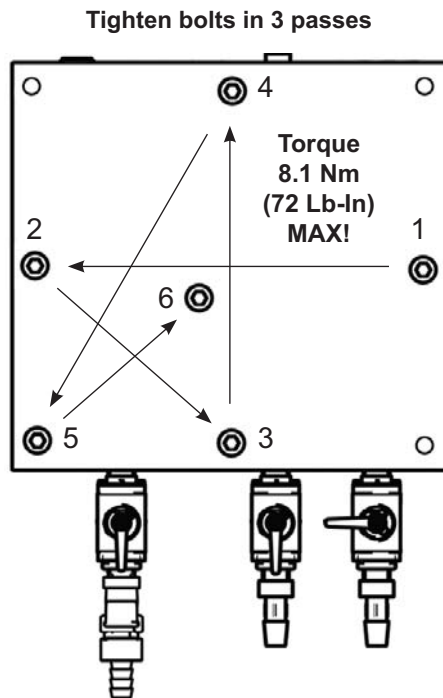

Tighten bolts in 3 passes

Torque
8.1 Nm
(72 Lb-In)
MAX!

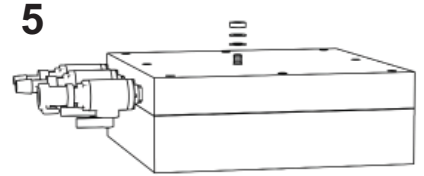

5

Install the nut and washers.

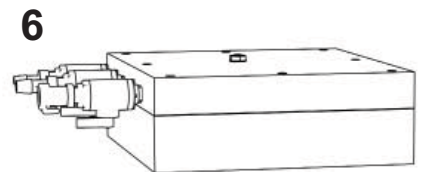

6

Tighten the nut just enough to hold the block together and keep the O-rings in place.

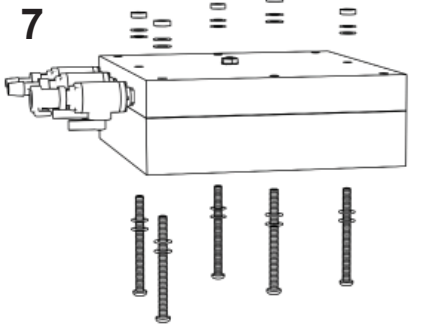

7

Install the remaining bolts, washers and nuts.

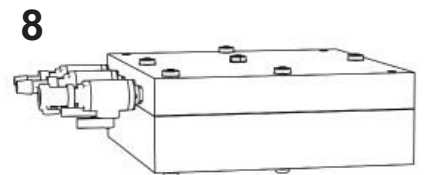

8

Tighten the bolts in three passes to specification.



9

Install the flow cell on the panel.
Screw on the thumb nuts finger tight.
Do not use tools on the thumb nuts.

NOTE: It is recommended that an anti-seizing compound appropriate for the application be used during the reassembling of the flow cell.

2. Maintenance - 2630 Amperometric Chlorine Electrode

Fill and Refill Procedure:

When adding electrolyte, be prepared for an accidental spill. Working near a sink is recommended.

1. Remove the membrane cap from the front of the sensor.
2. Turn the sensor upside down and shake the sensor vigorously to remove the internal electrolyte.
3. Fill supplied syringe with electrolyte solution.
4. Place the electrode on a level surface.
5. Insert syringe needle fully into one of the four electrode holes while injecting with electrolyte solution. The electrode holds approximately 14 milliliters of solution. Insert the needle to the bottom to avoid creating bubbles. Carefully fill until solution begins to flow out of holes. Do not allow the solution to run down the electrode and wet the electrical contacts in the DryLoc connector.
6. Slowly screw on the membrane cap finger tight. Do not use tools. To avoid damage and contamination, do not touch the white membrane surface on the membrane cap.

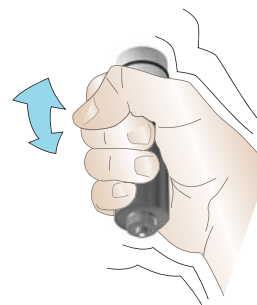

It is required to calibrate the sensor after servicing the membrane and electrolyte. Refer to section II, section 7.

2.1 Storage

Store electrode between $-10\text{ }^{\circ}\text{C}$ to $60\text{ }^{\circ}\text{C}$ ($-4\text{ }^{\circ}\text{F}$ to $140\text{ }^{\circ}\text{F}$) at a relative humidity that does not exceed 95%. The primary concerns when storing the electrode is membrane dehydration and freezing in extremely cold environments.



Storage Time	Action
≤ 7 Days	Store electrode in the flow cell with water to prevent membrane dehydration.
> 7 Days	Store electrode with the protective cover for the membrane attached; or immerse the end of the electrode in a small container of water to keep the membrane wet. Do not get the electrical contacts on the DryLoc end of the electrode wet.
> 1 month	Unscrew the membrane cap and store it fully immersed in tap water. Remove the electrolyte from the electrode by holding it over a container and shaking it or use a syringe and needle to withdraw the solution.

2.2 Disposal

The electrode is not recyclable. Dispose of properly according to local, state and federal guidelines.

3. Maintenance - 2724 DryLoc pH Electrode

3.1 Electrode Care and Application

pH electrodes are similar to batteries; they age with time and usage. The following information will help maximize electrode life.

General Tips:

- To ensure uninterrupted operation of critical pH systems, replacement electrodes should be available.
- Store boxed electrodes flat or upright (electrode tip down) to maximize hydration of the glass surface.
- Keep the glass surface wet at all times.
- Soak the sensor tip in pH 4.0 buffer during system maintenance intervals.
- If the sensor dehydrates, soak the sensor tip in pH 4 buffer for 24 to 48 hours, then visually inspect the electrode for surface cracks, swelling, or discoloration.
- It may not be possible to restore severely dehydrated electrodes to normal operation.
- High temperatures, strong acids or caustics will increase electrochemical reactions and speed electrode aging.
- Coatings (e.g. grease) on the glass or junction surfaces cause extended response time and inaccurate measurement.
- Never store the electrode tip in deionized (DI) water. Use pH 4 buffer solution to keep the glass wet when out of the process.
- Never store the electrode at temperatures below 0 °C (32 °F) or allow it to dehydrate.
- Never scrape or sand the glass electrode surface.
- Treat glass electrode surfaces with care to prevent accidental breakage.

3.2 Cleaning

Problem	Suggested Solution
Hard Coatings	Use a dilute acid solution (HCl solution of 5% or less). If the electrode has been used in applications with a pH value higher than 7 pH, soak the electrode for 2 to 5 minutes.
	Use a dilute alkaline solution (NaOH solution at 5% or less) if the electrode has been used in applications with pH values less than 7 pH, soak the electrode for 2 to 5 minutes.
	Alternating immersion in acidic and alkaline solutions may be necessary for thorough cleaning.
Soft Coatings	Spray or vigorously stir the electrode with a mild detergent, such as dishwashing liquid. Chlorine bleach can also be used.
Oily or Organic Coatings	Spray or vigorously stir the electrode with a mild detergent or an appropriate solvent that will not attack the materials of construction (isopropyl alcohol or similar).
After Cleaning	Always rinse the electrode with water after cleaning.
	Soak the electrode in a pH 4 buffer (with KCl if available) for at least 10 minutes after cleaning.

4. Troubleshooting - 4630 Chlorine Analyzer

The troubleshooting table below outlines possible causes and remedies related to the flow cell panel system. Refer to the transmitter and sensor manuals for specific component troubleshooting.

Problem	Possible Cause	Remedies
No water flow	Inlet pressure below 1 bar (15 psi)	Check source pressure. Remove regulator if pressure is < 1 bar/15 psi
	Damaged flow regulator	Replace flow regulator
	Clogged filter	Clean filter or remove pressure regulator if inlet pressure is below 1 bar (15 psi)
Low water flow	Clogged filter	Clean filter
	Insufficient inlet pressure	Increase inlet pressure to specification or remove flow regulator
	Damaged flow regulator	Inspect or replace
Excessive flow	Excessive pressure over 8 bar (120 psi)	Ensure inlet pressure does not exceed 8 bar (120 psi)
	Damaged flow regulator	Replace flow regulator
Flow cell leaks	Incorrect assembly	Inspect, clean, and reassemble
	Loose bolts	Tighten bolts (8.1 Nm, 72 Lb-In Max)
	Defective or missing O-rings	Replace O-rings
	Damaged sealing surfaces	Replace flow cell
Leaks around sensor	Damaged sensor O-ring	Inspect or replace O-ring
	Damaged flow cell	Inspect flow cell
Water leaks out of top vent hole	Drain valve closed or plugged	Inspect
	Hose connections are backwards	Connect water source correctly
	Outlet drain not below flow cell	Route drain line below flow cell and vented to atmosphere
Algae growth in flow cell	Low chlorine concentration in water	Locate flow cell away from light
	Exposure to light	
Excessive small bubbles in flow cell accumulating on sensors	Water source contains bubbles	Check water source
	Water source is saturated with dissolved gasses	
Transmitter does not turn on	No power or external circuit breaker is switched off	Inspect power and wiring connections
	Loose or incorrect wire connections	Check connections
	Open loop wiring or missing jumper wire on terminal 1 (Loop 1) on the wiring enclosure terminal block	Replace jumper wire to terminal 1 or connect a loop device if the jumper wire to terminal 1 is removed
Chlorine reading too high	Breached membrane	Replace membrane and fill solution
Chlorine reading too low	Low flow rate	Check source pressure
	Filter clogged	Clean the filter
	Sensor conditioning not long enough	Allow the sensor to condition for 4 hours (See 2630 sensor manual for details)
Sensor output drifts	Variable flow rate	Check flow rate
	Clogged filter	Clean the filter
	Contaminated fill solution	Change electrolyte fill solution
Chlorine Electrode Troubleshooting (see 2630-2 electrode manual)		
Transmitter Troubleshooting (see 8630-3 transmitter manual)		
pH Electrode Troubleshooting (see 2724 electrode manual)		

5. Troubleshooting - 8630 Chlorine Transmitter

Several factors can cause irregular or incorrect readings. The first thing to check is to verify that the transmitter and sensors have been installed correctly. The list below outlines possible causes and remedies.

Transmitter Troubleshooting		
Problem	Possible Cause	Remedies
Transmitter does not turn on.	Incorrect wiring. No or low voltage supplied to transmitter. Blown fuse. Bad wire connections or splices.	Check wiring, power supply and wiring connections.
Display screen is too dark or too dim.	Contrast set incorrectly or ambient temperature is too high.	Adjust contrast in Options Menu.
LCD backlight, relays and sensors do not work.	No power supplied to terminals 1 and 2.	Transmitter requires power to terminals 1, 2, 3 and 4.
Incorrect temperature reading.	Faulty chlorine sensor. Bad sensor connection.	Check connections or replace sensor.
Digital or Current output is erratic.	Electrical noise interfering with the measurement. Sensor malfunction.	Ensure system is properly grounded. See Sensor Troubleshooting.
Output is not zero when electrode is placed in non-chlorinated water.	Electrode not properly conditioned. Noise interfering with the measurement. Calibration incorrect.	Condition new sensor for 4 hours. Cap replacement or electrolyte refill: 2 hours. Properly ground system. Replace sensor.
4 to 20 mA output is incorrect.	4 to 20 mA is not scaled same as Loop device. Loop device is not scaled same as sensor.	Re-span loop device to match sensor.
Chlorine Sensor Troubleshooting (see 2630 sensor manual)		
Incorrect readings	Sensor conditioning time too short.	Run for 4 hours before calibrating.
	Membrane cap damaged or contaminated.	Clean or replace cap.
	Interference from water contaminants.	See Specifications data.
	Low flow rate.	Check flow.
	Air bubbles on membrane.	Install flow cell vertically with upwards flow.
	pH outside working range (See Specifications data).	Check pH.
	Low or no electrolyte in sensor.	Fill sensor with electrolyte.
	Membrane cap loose.	Inspect/tighten (do not use tools).
	Only combined chlorine present when measuring free chlorine.	Validate with DPD test.
	Sensor not making good contact with electronics.	Inspect and reconnect.
	Defective sensor.	Replace.
	No pH compensation being used.	Manually enter pH value in Options or calibrate pH sensor.
	Cl sensor not calibrated.	Calibrate Cl sensor.

5.1 Transmitter Error Messages

The 8630 error warnings are self-explanatory. An error message can appear under the following circumstances:

- User input value is out of range
- Poor electrical connection
- Sensor is not connected or detected
- Temperature error
- Incorrect sensor type chosen in the Options Menu
- Two calibration points are too close together when calibrating pH or chlorine.

Error Messages	Problem	Possible Cause	Remedies
Sens Data Error	Cl sensor data memory error.	Cl sensor is not connected. Damaged sensor.	Check Cl sensor wiring and connection. Perform a "Find New Sensor" or recycle power afterward.
CHK Cl PREAMP	Cl preamp is not detected.	Cl preamp is not connected. Wrong wiring. Damaged preamp.	Check preamp and transmitter wiring. Perform a "Find New Sensor" or recycle power afterward.
CHK pH PREAMP	pH preamp is not detected.	pH preamp is not connected. Wrong wiring. Damaged preamp.	Check preamp and transmitter wiring. Perform a "Find New Sensor" or recycle power afterward.
CHK Cl SENSOR	Cl sensor is not detected.	Cl sensor not connected. Damaged sensor.	Check sensor connection.
CHK pH SENSOR	pH sensor is not detected.	pH sensor is not connected. Damaged sensor.	Check sensor connection.
Out Of Range CHECK SENSOR	pH calibration error.	pH values are out of range.	Enter proper values during calibration.
Standard Too Close To Slope!	pH standard calibration point is too close to slope point.	Wrong data is entered. pH buffer solution used has value too close to standard point.	Re-enter correct data. Use proper buffer solution at least 2 pH units apart from slope buffer solution.
Slope Too Close To Standard!	pH slope calibration point is too close to standard point.	Wrong data is entered. pH buffer solution used has value too close to standard point.	Re-enter correct data. Use proper buffer solution at least 2 pH units apart from standard buffer solution.
Signal Too Close To Other Cal Pt	The signal level of Cl for In-process calibration is too close to the Zero Cal Point.	The Cl solution used for In-process calibration is too close to Zero Cal. These two points must be 1 nA apart.	Use proper solution at least 1 nA apart.
Cl Value Must Be > = 0.2 ppm	The Cl value entered during In-process calibration is too small.	Wrong data is entered. The value entered must be at least 0.2 ppm (mg/l).	Re-enter correct value.

Transmitter Error Messages - continued

<p>Signal Too High Must Be =< 10 nA</p>	<p>The signal level during Zero calibration is too high. Signal must be equal or less than 10 nA.</p>	<p>The sensor is not stabilized. The solution used has too much chlorine.</p>	<p>Wait for sensor stabilization. Check solution to ensure that the chlorine level is close to zero ppm (mg/l).</p>
<p>pH Too High Must be =< 9</p>	<p>pH value is too high.</p>	<p>During In-Process calibration the pH value is too high and must be less than or equal to 9.</p>	<p>Check pH.</p>
<p>pH Too Low Must be >= 4</p>	<p>pH value is too low.</p>	<p>During In-process calibration the pH value is too low and must be greater than or equal to 4.</p>	<p>Check pH.</p>
<p>FC1= - - - - - CHK pH SENSOR</p>	<p>pH sensor is not detected.</p>	<p>pH sensor is not connected. Wrong wiring. Damaged pH sensor.</p>	<p>Check pH sensor connections or change pH input to Manual in Options Menu.</p>
<p>FC1= - - - - - CHK pH PREAMP</p>	<p>pH preamp is not detected.</p>	<p>pH preamp is not connected. Wrong wiring. Damaged preamp.</p>	<p>Check pH preamp wiring. Perform a "Find New Sensor" or recycle power afterward.</p>
<p>FC1= WRONG SENSOR</p>	<p>Wrong sensor is detected.</p>	<p>Different type of sensor is connected. Wrong sensor type is selected under Option Menu.</p>	<p>Use correct sensor type. Perform a "Find New Sensor" or recycle power afterward. Select correct sensor type under Option Menu.</p>

NOTE: Whenever a new type of C1 Sensor is connected to the preamp, a power recycling is required. Another option is to perform a "Find New Sensor" under the Option Menu.

6. Troubleshooting - 2630 Amperometric Chlorine Electrode

Transmitter error messages related to calibration are detailed in the Signet 8630 Chlorine Transmitter operation manual.

Problem	Possible Causes	Remedies
Sensor cannot be calibrated. Output is higher than DPD test (out of range).	Sensor conditioning time too short	Condition for 4 hours minimum prior to initial calibration
	Interference from contaminants	See Specifications data
	Membrane cap damaged	Replace cap and recondition
	DPD chemicals bad	Use fresh reagents
	pH outside of working range	See Specifications data
Sensor cannot be calibrated. Output is lower than DPD test.	Sensor conditioning time too short	Condition for 4 hours minimum prior to initial calibration
	Chlorine content too low	DPD value must be greater than 0.5 ppm to calibrate
	Low flow rate	Check to make sure flow rate is sufficient
	Air bubbles on electrode membrane	Inspect visually. Tap to remove bubbles. Mount at an angle.
	Low or no electrolyte in electrode	Fill electrode with electrolyte
	Organic chlorination agents present in water	See Specifications data
	Surfactants in water	Remove surfactants and replace cap
	Membrane cap coated	Clean or replace membrane cap
	Membrane cap loose	Tighten or replace membrane cap
pH outside working range.	See Specifications data	
Sensor output very low	Sensor conditioning time too short	Condition for 4 hours minimum prior to initial calibration
	Chlorine content too low	Add chlorine to validate
	Only bound chlorine present. No free chlorine	Check for chloramine with appropriate DPD test
	Electrode not making good contact with electronics	Inspect and reconnect
Unstable output from sensor	Air bubbles on electrode membrane	Inspect visually. Tap to remove bubbles. Mount at an angle.
	Membrane damaged	Replace membrane. Condition sensor for at least 2 hours and recalibrate.
	Electrode not making good contact with electronics	Inspect and reconnect
	Non-sensor problem	Check 3-2650 Electronics connection to electrode (see 3-2650 manual for instructions). Make sure connections are dry. Check instrument hookup.

7. Troubleshooting 2750-7 pH Electronics

Problem	Possible Cause	Remedies
After completing calibration procedure, the output values are inaccurate.	Insufficient time allowed for electrode stabilization during calibration.	Recalibrate, verify that test solutions are at room temperature and wait at least 30 seconds after placing electrode in solution.
Transmitter Troubleshooting (see 8630-3 transmitter manual)		
pH Electrode Troubleshooting (see 2724 electrode manual)		

8. Specifications - 4630 Chlorine Analyzer

General

Compatible Sensors:

Signet 3-2630-2 Free Chlorine Sensor
Signet 3-2724-00 Flat pH Electrode

Materials:

Panel: Black Acrylic
Flow Cell: Acrylic
Wiring Enclosure: Polycarbonate

Wetted Materials:

Acrylic (flow cell, spacer rings)
Polycarbonate (flow regulator housing)
Stainless steel (strainer, e-clip, regulator spring, float)
Polypropylene (valves, vent)
EPDM, FKM (flow cell O-rings, diaphragm)
PVC, PVDF, FPM (Chlorine electrode)
PPS, Glass, UHMW, PE, FPM (pH electrode)
PTFE (sealing tape on valves, plug and vent)
Polyethylene (plug)

Performance

System Inlet Pressure Rating:

1 to 8 bar (15 to 120 psi)

Pressure Regulator:

< 0.69 bar (10 psi) variation over all ranges of flow and pressure

Electrical

AC Input - Standard Configuration:

100 to 240 VAC nominal (85 to 264 VAC),
50 to 60 Hz (47 to 63 Hz), 0.17 A at 100 VAC

DC Input - Optional Configuration:

12 to 24 VDC \pm 10% regulated, 10 W, 250 mA max

NOTE:

Power Supply 7300-0024 (standard with system)
90 - 264 V, 0.336 - 0.168 A, 0.316 A @ 100 V, 50 to 60 Hz

Optional power supply 7300-7524
100-240 VAC, 0.38 - 0.24 A, 50-60 Hz

Environmental Requirements

Storage Temperature:

0 to 65 °C (32 to 149 °F)

Operating Temperature:

0 to 45 °C (32 to 113 °F)

Relative Humidity:

0 to 95%

Maximum Altitude:

2000 m (6562 ft)

Enclosure:

NEMA 4X (with output wire glands sealed)

Standards and Approvals

CE

UL

 China RoHS (Go to www.gfsignet.com for details)

Shipping Weight

10 kg (22 lbs)

* Material Safety Data Sheets (MSDS) are available online at www.gfsignet.com.

9. Specifications - 8630 Chlorine Transmitter

General

Compatible Sensors:

Signet 3-2630-2 Free Chlorine Sensor
Signet 3-2724-00 Flat pH Sensor

Compatible Electronics

Signet 3-2650-7 Amperometric Electronics
Signet 3-2750-7 pH Sensor Electronics

Materials:

Case: PBT
Panel case gasket: Neoprene
Window: Polyurethane-coated polycarbonate
Keypad: Silicone rubber

Display:

LCD: Backlit alphanumeric 2 x 16 dot matrix
Keypad: Silicone rubber
Display update rate: 1 second
Contrast: User selected, 5 levels

Performance

System Operational Ranges/Limits (Chlorine):

Free Cl: 0 to 5 ppm

pH Input Range:

0 to 14 pH

Chlorine Compensation Range:

pH: 5.0 to 9.0 pH (Free Chlorine)
Temperature range: 0 to 45 °C (32 to 113 °F)

Maximum Cable Distance (sensor to transmitter):

Digital (S³L): 30 m (100 ft) maximum
4 to 20 mA output: 305 m (1000 ft) maximum

Electrical

Power Supply Requirement:

12 to 24 VDC ±10% regulated, 250 mA max current

Sensor Power (provided by 8630):

5 VDC ±1% @ 25 °C, regulated

Input Specifications:

One Digital (S³L) input from Free Chlorine,
One Digital (S³L) input from pH sensor

Output Specifications:

Current Loop (2 loops provided)

4 to 20 mA, isolated, adjustable span,
reversible with minimum and maximum
endpoint adjustment.

Ability to use chlorine or temperature as input

Update Rate: 300 ms

Max Loop impedance:

50 Ω max. @ 12 V

325 Ω max. @ 18 V

600 Ω max. @ 24 V

Relay Outputs:

2 mechanical SPDT contacts with adjustable
hysteresis and programmable High, Low, Off,
Pulse or Window range.

Maximum voltage rating:

5 A @ 30 VDC

5 A @ 250 VAC, resistive load

May be disabled if not used

Time delay: Programmable from 0 to 6400 s

Environmental Requirements

Operating Temperature:

-25 to 120 °C (-13 to 248 °F) transmitter only

Storage Temperature:

-15 to 80 °C (5 to 176 °F)

Relative Humidity:

0 to 95%, non-condensing

Maximum Altitude:

2000 m (6562 ft)

Enclosure:

NEMA 4X

Standards and Approvals

CE

UL

Manufactured under ISO 9001 and ISO 14001

 China RoHS (Go to www.gfsignet.com for details)

10. Specifications - 2650 DryLoc Amperometric Electronics

General

Compatible Sensors:

All Signet Amperometric DryLoc Sensors

Compatible Instruments:

Signet 3-8630-3P Chlorine Transmitter

Mounting:

DryLoc connection

Materials:

Valox® (PBT)

Cable:

4.6 m (15 ft) 3 conductor shielded, 22 AWG

Shipping Weight:

0.64 kg (1.14 lb)

Performance

Electronics Accuracy:

< 5 nA or 1% of reading, whichever is greater
@ 25 °C over full input range

Temperature:

± 1.0 °C (PT1000) over full operation range
(when calibrated at ambient temperature)

System Response:

500 ms (update rate)

Operational Range:

± 450 mV

Resolution: 0.1 nA

Electrical

Input Specifications:

Sensor: Raw signal

Temperature: PT1000 RTD

Output Specifications:

Digital (S³L): Serial ASCII, TTL level 9600 bps

Maximum Cable Length: 30 m (100 ft)

Power Supply Input:

Digital (S³L) mode:

5 to 6.5 V ± 10%, 3 mA max

Environmental

Storage Temperature:

-20 to 85 °C (-4 to 185 °F)

Operating Temperature:

0 to 85 °C (32 to 185 °F). Electronics only

Relative Humidity:

0 to 95%, non-condensing (no electrode connected)

Enclosure Requirements:

NEMA 4X/IP65 with electrode connected

Standards and Approvals

CE

Manufactured under ISO 9001 and ISO 14001

 China RoHS (Go to www.gfsignet.com for details)

11. Specifications - 2750-7 pH Electronics

General

Compatible Electrode:

Signet 2724-00 Flat pH electrode

Compatible Instrument:

Signet 3-8630-3P Chlorine Transmitter

Mounting:

DryLoc connection

Materials:

Valox® (PBT)

Cable:

4.6 m (15 ft) 3 conductor shielded, 22 AWG

Shipping Weight:

0.64 kg (1.14 lb)

Performance

Electronics Accuracy:

± 0.03 pH @ 25 °C

Resolution:

0.02 pH

Response Time (includes electrode response):

< 6 s for 95% of change

Operational Range:

0.00 to 14.00 pH

Resolution:

0.02 pH

Electrical

Input Specifications:

Input Impedance: >10¹¹ Ω

Temperature Drift: ±0.002 pH per °C

Input Resolution: 0.02 pH, 0.3 °C

Output Specifications:

Digital (S³L): Serial ASCII, TTL level 9600 bps

Maximum Cable Length: 30 m (100 ft)

Environmental

Storage Temperature:

-20 °C to 85 °C (-4 °F to 185 °F)

Operating Temperature (Electronics Only):

0 °C to 85 °C (32 °F to 185 °F)

Relative Humidity:

0 to 95%, non-condensing

Enclosure Requirements:

NEMA 4X/IP65 with electrode connected

Standards and Approvals

CE

Manufactured under ISO 9001 and ISO 14001

 China RoHS (Go to www.gfsignet.com for details)

* Valox® is a registered trademark of SABIC Innovative Plastics

12. Specifications - 2630-2 Amperometric Chlorine Electrode

General

Polarization Source:

Signet 2650 Amperometric Electronics

Compatible Flow Cells:

Signet 3-3610-1 (159 001 683)

Signet 3-3610-2 (159 001 684)

Signet 3-4630.392 (159 001 690)

Mounting:

Signet DryLoc connection

Materials:

CPVC

Free Chlorine:

Membrane material: PVDF

O-ring material: FPM

Working electrode: Gold

Counter reference electrode: Silver halide

Wetted Materials:

PVC, PVDF, FPM

Performance

Electrode:

Repeatability: ± 0.08 ppm (mg/l) or 3% of selected range whichever is less

Slope: 10 to 60 nA/ppm (mg/l)

Response time, T90: < 2 minutes

System: (including electronics and instrument)

Accuracy: < $\pm 3\%$ of electrode signal after calibration

Resolution: $\leq 0.5\%$ of electrode range

Sensor Conditioning:

New, first start-up:

4 hours maximum before calibration

Subsequent start-ups:

2 hours maximum

Temperature Element:

PT1000, Class B with measurement range of

-50 to 150 °C (-58 to 302 °F)

(measurement only, not operating specification)

Operational Ranges and Limits

Free Chlorine Range:

0 to 5 ppm (mg/l)

Free Chlorine pH Operating Range:

5.5 pH to 9.0 pH

Operating Temperature:

0 °C to 45 °C (32 °F to 113 °F)

Maximum Operating Pressure:

Membrane:

1 bar @ 25 °C (14 psi @ 77 °F)

Flow Cell:

8 bar @ 25 °C (120 psi @ 77 °F)

Flow Velocity Across Membrane Surface:

Minimum: 15 cm/s (0.49 ft/s)

Maximum: 30 cm/s (0.98 ft/s)

Free Chlorine Cross Sensitivity:

ClO₂, ozone, bromine

Chemical Compatibility:

< 50% ethanol/water, < 50% glycerol/water

Environmental Requirements

Storage Temperature (dry):

-10 to 60 °C (-4 to 140 °F)

Operating Temperature:

0 to 45 °C (32 to 113 °F)

Relative Humidity:

0 to 95% indoor/outdoor non-condensing to rated ambient

Standards and Approvals

CE

Manufactured under ISO 9001

 China RoHS (Go to www.gfsignet.com for details)

13. Specifications - 2724 DryLoc pH Electrode

General

Compatible Sensors:

2750 Electronics

pH temp Sensor:

PT1000 versions are compatible with Signet 2750 pH/ORP Sensor electronics.

Process Connection:

¾ in. NPT or ISO 7/1 R¾ threads or Signet flow fittings

Wetted Materials:

- pH: PPS, glass, UHMW PE, FPM

Shipping Weight:

0.25 kg (0.55 lb)

Performance

Efficiency

>97% @ 25 °C (77 °F)

Efficiency indicates the "wellness" of a new electrode. Efficiency is measured by comparing the actual slope (mV/pH) at 25 °C to the theoretical output of 59.16 mV/pH. An efficiency of 97% to 100% is equivalent to a slope of 57.39 to 59.16 mV/pH.

Measuring Range:

pH: 0 to 14 pH

Standards and Approvals

Manufactured under ISO 9001 and ISO 14001



China RoHS (Go to www.gfsignet.com for details)

Recommended Storage Temperature

- The best storage temperature for the 272X pH and ORP electrodes is 0 °C to 50 °C (32 °F to 122 °F).
- The electrode glass will be shattered if shipped or stored at temperatures below 0 °C (32 °F).
- The performance life of the electrode will be shortened if stored at temperature above 50 °C (122 °F).

14. Ordering Information - 4630 Chlorine Analyzer

Mfr. Part No.	Code	Description
3-4630-20	159 001 691	Chlorine panel, transmitter, free chlorine sensor (0 to 5 ppm) with electronics, no pH sensor
3-4630-21	159 001 692	Chlorine panel, transmitter, free chlorine sensor (0 to 5 ppm) with sensor electronics, pH sensor with electronics
3-2630-2	159 001 662	Free Chlorine sensor, 0 to 5 ppm (mg/l)
3-2724-00	159 001 545	pH electrode, flat glass, PT1000 temp element, 3/4 in. NPT
3-2650-7	159 001 670	Chlorine - Inline Amperometric Electronics, Digital (S ³ L), 4.6 m (15 ft) cable
3-2750-7	159 001 671	pH - Inline Electronics, Digital (S ³ L), 4.6 m (15 ft) cable
3-8630-3P	159 001 673	Panel mount chlorine and pH transmitter

Accessories and Replacement Parts

Mfr. Part No.	Code	Description
3-4630.390	159 001 688	Rebuild kit, O-rings, boots, screws, 1 filter screen
3-4630.391	159 001 689	Pressure regulator with 1 spare filter screen
3-4630.392	159 001 690	Acrylic flow cell complete with all components and connections
7300-0024	159 001 693	24 VDC Power Supply
3-2630.391	159 001 674	Free Chlorine electrolyte, 30 ml
3-2630.392	159 001 675	Free Chlorine replacement membrane (1)
3-2630.396	159 001 676	Free Chlorine replacement kit - (2) electrolyte and (2) membranes
3-0700.390	198 864 403	pH Buffer Kit (1 each 4, 7, 10 pH buffer in powder form, makes 50 ml of each)
3822-7004	159 001 581	pH 4.01 buffer solution, 1 pint (473 ml) bottle
3822-7007	159 001 582	pH 7.00 buffer solution, 1 pint (473 ml) bottle
3822-7010	159 001 583	pH 10.00 buffer solution, 1 pint (473 ml) bottle
3-2700.395	159 001 605	Calibration kit: included 3 polypropylene cups, box used as cup stand, 1 pint pH 4.01, 1 pint pH 7.00

15. Ordering Information - 8630 Chlorine Transmitter

Mfr. Part No.	Code	Description
3-8630-3P	159 001 673	Panel mount chlorine and pH transmitter

Accessories and Replacement Parts

Mfr. Part No.	Code	Description
3-2630.391	159 001 674	Free Chlorine electrolyte, 30 ml
3-2630.392	159 001 675	Free Chlorine replacement membrane (1)
3-2630.396	159 001 676	Free Chlorine replacement kit - (2) electrolyte and (2) membranes
3-0700.390	198 864 403	pH Buffer Kit (1 each 4, 7, 10 pH buffer in powder form, makes 50 mL)
3822-7004	159 001 581	pH 4.01 buffer solution, 1 pint (473 ml)
3822-7007	159 001 582	pH 7.00 buffer solution, 1 pint (473 ml)
3822-7010	159 001 583	pH 10.00 buffer solution, 1 pint (473 ml)
3-2700.395	159 001 605	Calibration kit: included 3 polypropylene cups, box used as cup stand, 1 pint pH 4.01, 1 pint pH 7.00

16. Ordering Information - 2630 Amperometric Chlorine Electrode

Mfr. Part No.	Code	Description
3-2630-2	159 001 662	Free Chlorine electrode, 0 to 5 ppm (mg/l)

Accessories and Replacement Parts

Mfr. Part No.	Code	Description
1220-0021	159 801 182	O-ring FPM
3-2630.391	159 001 674	Free Chlorine electrolyte, 30 ml
3-2630.392	159 001 675	Free Chlorine replacement membrane (1)
3-2630.396	159 001 676	Free Chlorine replacement kit - (2) electrolyte and (2) membranes
3-0700.390	198 864 403	pH Buffer Kit (1 each 4, 7, 10 pH buffer in powder form, makes 50 mL)
3822-7004	159 001 581	pH 4.01 buffer solution, 1 pint (473 ml)
3822-7007	159 001 582	pH 7.00 buffer solution, 1 pint (473 ml)
3822-7010	159 001 583	pH 10.00 buffer solution, 1 pint (473 ml)
3-2700.395	159 001 605	Calibration kit: included 3 polypropylene cups, box used as cup stand, 1 pint pH 4.01, 1 pint pH 7.00

17. Ordering Information - 2724 pH Electrode

Mfr. Part No.	Code	Description
3-2724-00	159 001 545	Electrode, pH, flat, PT1000, 3/4 in. NPT

Accessories and Replacement Parts

Mfr. Part No.	Code	Description
3-2750-7	159 001 671	pH electronics, Digital (S ³ L), 4.6 m (15 ft) cable
3-2759	159 000 762	pH/ORP System Tester (adapter cable sold separately)
3-2759.391	159 000 764	2759 DryLoc Adapter Cable (for use with 2750 and 2760)
3-0700.390	198 864 403	pH Buffer Kit (1 each 4, 7, 10 pH buffer in powder form, makes 50 mL)
3822-7004	159 001 581	pH 4.01 buffer solution, 1 pint (473 ml)
3822-7007	159 001 582	pH 7.00 buffer solution, 1 pint (473 ml)
3822-7010	159 001 583	pH 10.00 buffer solution, 1 pint (473 ml)
3-2700.395	159 001 605	Calibration kit: included 3 polypropylene cups, box used as cup stand, 1 pint pH 4.01, 1 pint pH 7.00

18. Ordering Information - 2750-7 pH Electrode

Mfr. Part No.	Code	Description
3-2750-7	159 001 671	pH electronics, Digital (S ³ L), 4.6 m (15 ft) cable



Georg Fischer Signet LLC, 3401 Aerojet Avenue, El Monte, CA 91731-2882 U.S.A. • Tel. (626) 571-2770 • Fax (626) 573-2057
For Worldwide Sales and Service, visit our website: www.gfsignet.com • Or call (in the U.S.): (800) 854-4090
For the most up-to-date information, please refer to our website at www.gfsignet.com