

EZ-ZONE[®] PM Express Users Manual



Limit Controller



**TOTAL
CUSTOMER
SATISFACTION**
3 Year Warranty

ISO 9001
Registered Company
Winona, Minnesota, USA

1241 Bundy Boulevard., Winona, Minnesota USA 55987

Phone: +1 (507) 454-5300, Fax: +1 (507) 452-4507 <http://www.watlow.com>

0600-0066-0000 Rev. C

Made in the U.S.A.



April 2010

Safety Information

We use note, caution and warning symbols throughout this book to draw your attention to important operational and safety information.

A "NOTE" marks a short message to alert you to an important detail.
A "CAUTION" safety alert appears with information that is important for protecting your equipment and performance. Be especially careful to read and follow all cautions that apply to your application.
A "WARNING" safety alert appears with information that is important for protecting you, others and equipment from damage. Pay very close attention to all warnings that apply to your application.

The electrical hazard symbol, ⚡ (a lightning bolt in a triangle) precedes an electric shock hazard CAUTION or WARNING safety statement. Further explanations follow:

Symbol	Explanation
	CAUTION – Warning or Hazard that needs further explanation than label on unit can provide. Consult users manual for further information.
	ESD Sensitive product, use proper grounding and handling techniques when installing or servicing product.
	Unit protected by double/reinforced insulation for shock hazard prevention.
	Do not throw in trash, use proper recycling techniques or consult manufacturer for proper disposal.
	Unit can be powered with either alternating current (ac) voltage or direct current (dc) voltage.

	Unit is a Listed device per Underwriters Laboratories [®] . It has been evaluated to United States and Canadian requirements for Process Control Equipment. UL 61010 and CSA C22.2 No. 61010, File E185611 QUYX, QUYX7. See: www.ul.com
	Unit is compliant with European Union directives. See Declaration of Conformity for further details on Directives and Standards used for Compliance.
	Unit has been reviewed and approved by Factory Mutual as a Temperature Limit Device per FM Class 3545 standard. See: www.fmglobal.com
	Unit has been reviewed and approved by CSA International for use as Temperature Indicating-Regulating Equipment per CSA C22.2 No. 24. See: www.csa-international.org

Warranty

The EZ-ZONE[®] PM is manufactured by ISO 9001-registered processes and is backed by a three-year warranty to the first purchaser for use, providing that the units have not been misapplied. Since Watlow has no control over their use, and sometimes misuse, we cannot guarantee against failure. Watlow's obligations hereunder, at Watlow's option, are limited to replacement, repair or refund of purchase price, and parts which upon examination prove to be defective within the warranty period specified. This warranty does not apply to damage resulting from transportation, alteration, misuse or abuse. The purchaser must use Watlow parts to maintain all listed ratings.

1 2
3 4

Technical Assistance

If you encounter a problem with your Watlow controller, review your configuration information to verify that your selections are consistent with your application: inputs, outputs, alarms, limits, etc. If the problem persists, you can get technical assistance from your local Watlow representative (see back cover), by e-mailing your questions to wintechsupport@watlow.com or by dialing +1 (507) 494-5656 between 7 a.m. and 5 p.m., Central Standard Time (CST). Ask for an Applications Engineer. Please have the following information available when calling:

- Complete model number
- All configuration information
- User's Manual
- Factory Page

Return Material Authorization (RMA)

1. Call Watlow Customer Service, (507) 454-5300, for a Return Material Authorization (RMA) number before returning any item for repair. If you do not know why the product failed, contact an Application Engineer or Product Manager.

The EZ-ZONE PM Controller User's Manual is copyrighted by Watlow Winona, Inc., © April 2010 with all rights reserved. The EZ-ZONE PM Express is covered by U.S. Patent No. 6,005,577 and Patents Pending.

Overview

The EZ-ZONE PM Express takes the pain out of solving your thermal loop requirements while reducing the cost of control-loop ownership. You can order this control as over-under Limit controller in either a 16th or 32nd DIN panel-mount packages.

It just got a whole lot easier to solve the thermal requirements of your system. Because the EZ-ZONE family of controls are highly scalable, you only **pay for what you need**. So if you are looking for a single or multi-loop PID controller, an over-under limit controller or an integrated controller (PID and Limit), the EZ-ZONE family of controls can meet all of your needs. Point your browser to <http://www.watlow.com> to find out more about the EZ-ZONE family of controls.

For this particular control, serial communications is accomplished using Watlow's Standard Bus protocol. If the need arises to network your controls and communicate using other popular protocols such as Modbus RTU/TCP[®], EtherNet/IP[™] or DeviceNet[™], consider using the EZ-ZONE family Remote User Interface/Gateway (RUI/GTW).

Installation and Wiring

Dimensions 1/32 DIN

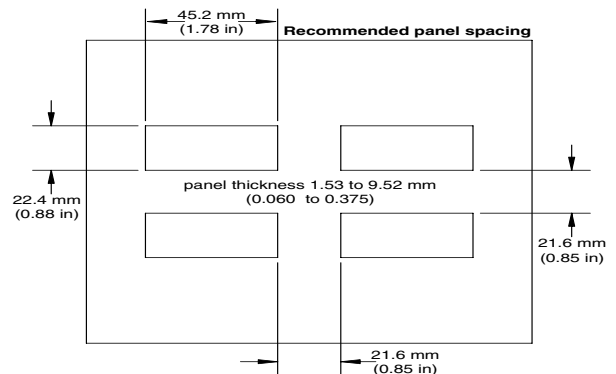
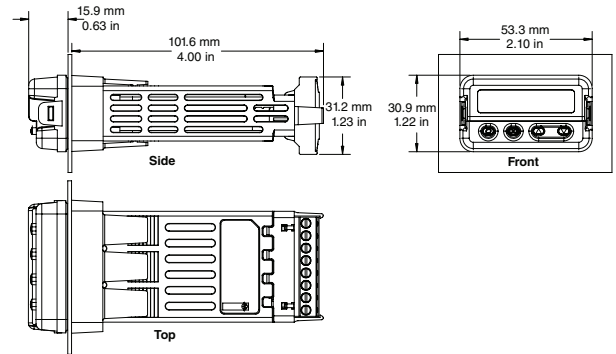

1/32 DIN Maximum Cutout

Dimensions 1/16 DIN

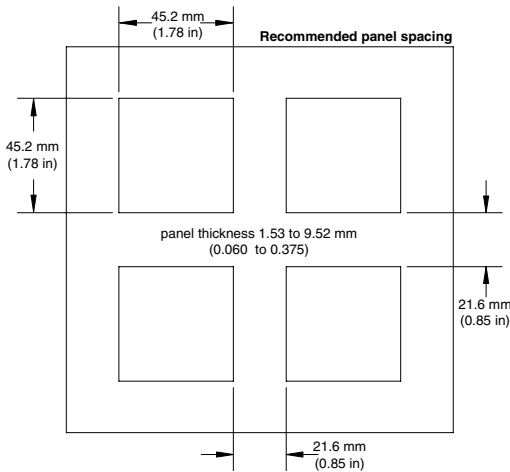
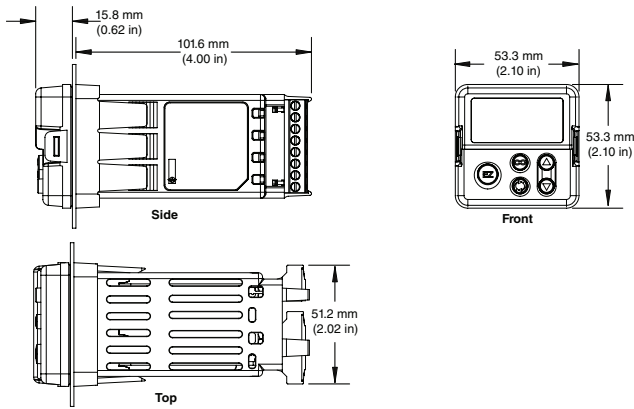

Installation

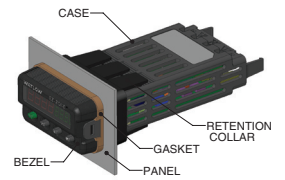
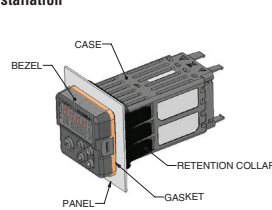

Removing the Mounted Controller from Its Case

1. From the controller's face, pull out the tab on each side until you hear it click.



Pull out the tab on each side until you hear it click.

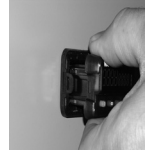

Grab the unit above and below the face and pull forward.

- Make the panel cutout using the mounting template dimensions in this chapter. Insert the case assembly into the panel cutout.
- While pressing the case assembly firmly against the panel, slide the mounting collar over the back of the controller.

If the installation does not require a NEMA 4X seal, slide the mounting collar up to the back of the panel tight enough to eliminate the spacing between the gasket and the panel.



Slide the mounting collar over the back of the controller.

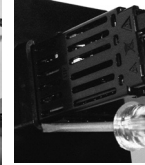

Place the blade of a screwdriver in the notch of the mounting collar assembly.

- For a NEMA 4X seal, place the blade of a screwdriver in the notch of the mounting collar assembly and push toward the front panel while applying pressure to the face of the controller. Don't be afraid to apply enough pressure to properly install the controller. The seal system is compressed more by mating the mounting collar tighter to the front panel (see picture). If you can move the case assembly back and forth in the cutout, you do not have a proper seal. The tabs on each side of the mounting collar have teeth that latch into the ridges on the sides of the controller. Each tooth is staggered at a different depth from the front so that only one of the tabs, on each side, is locked onto the ridges at a time.

- Once the sides are released, grab the unit above and below the face with two hands and pull the unit out. If it is difficult to pull the unit out, remove the connectors from the back of the controller. This should make it easier to remove.

Warning:

All electrical power to the controller and controlled circuits must be disconnected before removing the controller from the front panel or disconnecting other wiring.

Returning the Controller to its Case

- Ensure that the orientation of the controller is correct and slide it back into the housing.

Note:

The controller is keyed so if it feels that it will not slide back in do not force it. Check the orientation again and reinsert after correcting.

- Using your thumbs push on either side of the controller until both latches click.

Chemical Compatibility

This product is compatible with acids, weak alkalis, alcohols, gamma radiation and ultra-violet radiation.

This product is not compatible with strong alkalis, organic solvents, fuels, aromatic hydrocarbons, chlorinated hydrocarbons, esters and keytones.

Terminal Definitions

Slot C	Terminal Function	Model
98 99	power input: ac or dc+ power input: ac or dc-	PM_(L)___ - AAAAB __
CF CD CE	Standard Bus EIA-485 common Standard Bus EIA-485 T-/R- Standard Bus EIA-485 T+/R+	PM_(L)___ - AAAAB __
Slot A		
Input 1		
T1 S1 R1	S2 (RTD) or current +, S3 (RTD), thermocouple -, current - or volts - S1 (RTD), thermocouple + or volts +	Universal Sensor input 1: all configurations
Outputs	Terminal Function	Configuration
1 2		
X1 W1 Y1	common (Any switched dc output can use.) dc- (open collector) dc+	Switched dc/open collector, output 1: PM_(L)_C_- AAAB __
L1 K1 J1	normally open common normally closed	Mechanical Relay 5 A, Form C, output 1: PM_(L)_E_- AAAB __
L2 K2	normally open common	Mechanical Relay 5 A, Form A, output 2: PM_(L)_J_- AAAB __

Note:

In the pictures below notice that the Slot A connector does not show labeling for the outputs. Labeling for Slot A outputs is based on the controller part number.

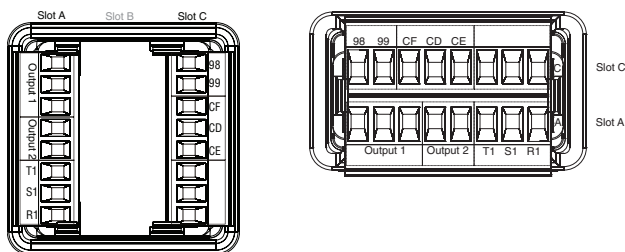

Warning:

Use National Electric (NEC) or other country-specific standard wiring and safety practices when wiring and connecting this controller to a power source and to electrical sensors or peripheral devices. Failure to do so may result in damage to equipment and property, and/or injury or loss of life.

Note:

- Maximum wire size termination and torque rating:
 - 0.0507 to 3.30 mm² (30 to 12 AWG) single-wire termination or two 1.31 mm² (16 AWG)
 - 0.8 Nm (7.0 lb.-in.) torque

Note:

Adjacent terminals may be labeled differently, depending on the model number.

Note:

To prevent damage to the controller, do not connect wires to unused terminals.

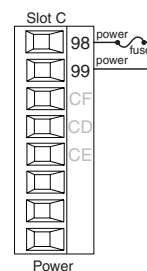

Power

- 47 to 63 Hz
- 10VA maximum power consumption
- Low Power**
 - 12 to 40V~ (dc)
 - 20 to 28V~ (ac) Semi Sig F47
- High Power**
 - 85 to 264V~ (ac)
 - 100 to 240V~ (ac) Semi Sig F47

Note:

In the drawings below for each input notice that the Slot A connector labeling is identified.

Note:

When using a 2 wire RTD, jumper S1 and T1 together.

Inputs

All inputs shown below represent input 1 the only input available on the Express Limit and is connected to slot A of the Control.

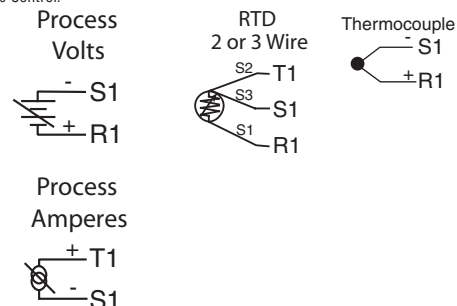

Inputs

Process Volts and Amperes

- 0 to 20 mA @ 100 Ω input impedance
- 0 to 10V= (dc) @ 20 kΩ input impedance
- Scalable

Resistance Temperature Detector (RTD)

- platinum, 100 Ω @ 0°C
- calibration to DIN curve (0.00385 Ω/Ω°C)
- 20 Ω total lead resistance
- RTD excitation current of 0.09 mA typical. Each ohm of lead resistance may affect the reading by 0.03°C.
- For 3-wire RTDs, the S1 lead (usually white) must be connected to R1.

- For best accuracy use a 3-wire RTD to compensate for lead-length resistance. All three lead wires must have the same resistance.

Thermocouple

- 2 KΩ maximum source resistance
- >20 MΩ input impedance
- 3 microampere open-sensor detection
- Thermocouples are polarity sensitive. The negative lead (usually red) must be connected to S1.
- To reduce errors, the extension wire for thermocouples must be of the same alloy as the thermocouple.

Outputs

Switched DC

- 22 to 32V=(dc) @ 40mA maximum supply current
- short circuit limited to <50 mA
- 22 to 32V=(dc) open circuit voltage
- Use dc- and dc+ to drive external solid-state relay.
- DIN-a-mite compatibility is for output 1 only.
 - single-pole: up to 4 in parallel or 4 in series
 - 2-pole: up to 2 in parallel or 2 in series
 - 3-pole: up to 2 in series

Open Collector

- 100 mA maximum output current sink
- 30V= (dc) maximum supply voltage
- Any switched dc output can use the common terminal.
- Use an external power supply to control a dc load, with the load positive to the positive of the power supply, the load negative to the open collector and common to the power supply negative.

See Quencharc note.

Mechanical Relay Form C

- 5 A at 240V~ (ac) or 30V= (dc) maximum resistive load, output 1
 - 20 mA at 24V minimum load
 - 125 VA pilot duty @ 120/240V~ (ac), 25 VA at 24V~ (ac)
 - 100,000 cycles at rated load
 - Output does not supply power.
 - for use with ac or dc
- See Quencharc note.

Mechanical Relay Form A

- 5 A at 240V~ (ac) or 30V= (dc) maximum resistive load, output 2
 - 20 mV at 24V minimum load
 - 125 VA pilot duty @ 120/240V~ (ac), 25 VA at 24V~ (ac)
 - 100,000 cycles at rated load
 - Output does not supply power.
 - for use with ac or dc
- See Quencharc note.

Outputs

Please note all outputs are connected exclusively to slot A. Output availability is based on the part number of your Limit Control.

Note:

In the drawings below for each output notice that the Slot A connector labeling is identified with the corresponding part number below.

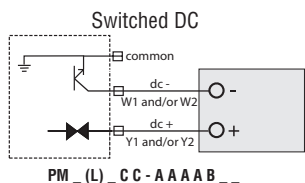
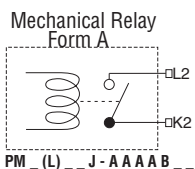
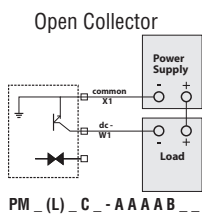
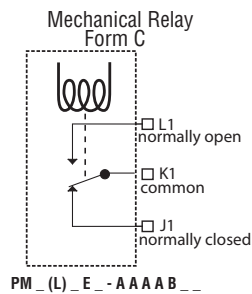

Quencharc Note:

Switching pilot duty inductive loads (relay coils, solenoids, etc.) with the mechanical relay, or open collector output options requires use of an R.C. suppressor.

9 10
11 12

**Keys & Displays
16th DIN LIMIT Controller**

Zone Display:

When [ZonE] (found in the Factory Page) is set to on, indicates the controller zone.

- [j] to [9] = zones 1 to 9
- [R] = zone 10
- [b] = zone 11
- [c] = zone 12
- [d] = zone 13
- [E] = zone 14
- [F] = zone 15
- [h] = zone 16

Lower Display:

Indicates the current state of the limit [FR.L] or [SAFE].

EZ Key:

Performs reset function.

RESET Key:

Press to reset limit after a trip condition has been cleared.

Upper Display:

On power up, displays the process value, otherwise displays the value of the parameter in the lower display.

Temperature Units Indicator Lights:

Indicates whether the temperature is displayed in Fahrenheit or Celsius.

Output Activity:

Number lights indicate activity of outputs 1 and 2.

Communications Activity:

Flashes when another device is communicating with this controller.

Up and Down Keys:

When in a menu scrolls through available options for any given prompt. In other menus can change set points and modify the upper display to a higher or lower value.

Advance Key: Advances through parameter prompts.

32nd DIN LIMIT Controller

With a few exceptions, all of the key functions described above for the 16th DIN LIMIT apply to the 32nd DIN LIMIT controller as well.

Left Display:

On power up, displays the process value, otherwise displays the value of the parameter in the right display.

Right Display:

Indicates the current state of the limit [FR.L] or [SAFE].

Responding to a Displayed Message (16th or 32nd DIN)

An active message will cause the display to toggle between the normal settings and the active message in the upper or left display and [REEn] in the lower or right display. Your response will depend on the message and the controller settings. If the message is generated by a latched alarm or limit condition, the message can be silenced [S.L] or cleared [C.R] by simply pushing the reset key (RES) when the condition no longer exists. [RL.L] Alarm 1 Low (sensor input below low alarm set point) [RL.H] Alarm 1 High (sensor input above high alarm set point)

- Alarm Error 1 to 4
- [ALE] Alarm 1 Error (alarm state cannot be determined due to lack of sensor input)
- [E.r.i] Error Input 1 (sensor is not providing a valid signal to the control)
- [L.L.L] Limit Low 1 (sensor input below low limit set point)
- [L.H.L] Limit High 1 (sensor input above high limit set point)
- [L.E.L] Limit Error 1 (limit state cannot be determined due to lack of sensor input, limit will trip)

Upon power up of the control, using the advance key will scroll through the various prompts found in the Operations Menu. At any point within the Operations menu to return to the default display push the Reset [RES] key.

Operations Menu

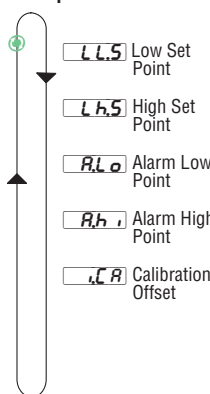

Operations Menu

16th & 32nd DIN Limit Controller

Display	Parameter Name Description	Range (Defaults are shown bold)
[LLS] [LL.S]	Limit Low Set Point Set the low process value that will trigger the limit. Appears if: Limit sides set to low or both.	-1,999.000 to 9,999.000°F or units -1,128.000 to 5,537.000°C Units, 0.0°F or -18.0°C
[Lh.S] [Lh.S]	Limit High Set Point Set the high process value that will trigger the limit. Appears if: Limit sides set to high or both.	-1,999.000 to 9,999.000°F or units -1,128.000 to 5,537.000°C Units, 0.0°F or -18.0°C
[ALo] [A.Lo]	Alarm Low Set Point Process - set the process value that will trigger a low alarm. Appears if: Alarm Type (A.ty) is set to Process Alarm	-1,999.000 to 9,999.000°F or units -1,128.000 to 5,537.000°C Units, 32.0°F or 0.0°C
[Ah.i] [A.hi]	Alarm High Set Point Process - set the process value that will trigger a high alarm. Appears if: Alarm Type (A.ty) is set to Process Alarm	-1,999.000 to 9,999.000°F or units -1,128.000 to 5,537.000°C Units, 300.0°F or 150.0°C
[i.CA] [i.CA]	Calibration Offset Set an offset value for a process output. Appears if: Always	-1,999.000 to 9,999.000°F or units -1,110.555 to 5,555.000°C 0.0

To enter the Setup Menu push and hold the up and down arrow keys for approximately 3 seconds. Once there, push the green advance key to scroll through to the prompt of choice and then use the up and down arrow keys to change the range. At any point within the Setup menu to return to the default display push the Reset **RES** key.

Setup Menu

- L o C** Lockout Menu
- S E n** Sensor Type
- L i n** Linearization
- d E C** Decimal
- C _ F** Display Units
- r L o** Range low
- r h i** Range High
- F n 1** Function One
- F n 2** Function Two
- L S d** Limit Sides
- L h y** Limit Hysteresis
- A L g** Alarm Logic
- A E y** Alarm Type
- A h y** Alarm Hysteresis
- A L A** Alarm Latching
- A b L** Alarm Blocking
- A S i** Alarm Silencing
- A d S P** Alarm Display
- P A r 1** Upper or Left Display
- P A r 2** Lower or Right Display
- A d S** Zone Address

Display	Parameter Name Description	Range (Defaults are shown bold)
L o C [LoC]	Lockout Menu Set the security clearance level. The user can access the selected level and all lower levels. Appears if: Always	1 to 5 1 Operations Menu (read only)* 2 Operations Menu (Set point R/W)* 3 Operations Menu (Set point R/W, Control Mode R/W)* 4 Operations Menu R/W access)* 5 Operations Menu and Setup Menu full R/W access *You can change the security level at any level
S E n [SEn]	Sensor Type Set the analog sensor type to match the device wired to this input. Appears if: Always.	<input type="checkbox"/> T C Thermocouple <input type="checkbox"/> m A Milliamps dc <input checked="" type="checkbox"/> V o l t s Volts dc <input type="checkbox"/> R T D RTD 100 Ω
L i n [Lin]	Linearization Set the linearization to match the thermocouple type wired to this input. For example, select <input type="checkbox"/> H for a type K thermocouple. Appears if: Sensor Type is set to Thermocouple.	<input type="checkbox"/> B <input type="checkbox"/> J <input type="checkbox"/> T <input type="checkbox"/> C <input type="checkbox"/> K <input type="checkbox"/> D <input type="checkbox"/> N <input type="checkbox"/> E <input type="checkbox"/> R <input type="checkbox"/> F <input type="checkbox"/> S
d E C [dEC]	Decimal Set the precision of the displayed value. Appears if: Always.	<input type="checkbox"/> W h o l e <input type="checkbox"/> T e n t h s <input type="checkbox"/> H u n d r e d t h s
C _ F [C.F]	Display Units Select which units will be displayed. Appears if: Always.	<input type="checkbox"/> F °F <input type="checkbox"/> C °C
r L o [r.Lo]	Limit Set Point - Range Low Set the low range for the Limit low set point. Appears if: Always.	-1,999.000 to 9,999.000 0.0
r h i [r.hi]	Limit Set Point - Range High Set the high range for the Limit high set point. Appears if: Always.	-1,999.000 to 9,999.000
F n 1 [fn1]	Function of Output 1 Select which function will drive this output. Appears if: Always.	<input type="checkbox"/> O f f Off * NOTE: Switched DC/Open Collector option should only be used to control an external mechanical relay if Limit function is selected. <input type="checkbox"/> L i m i t Limit* <input type="checkbox"/> A l a r m Alarm
F n 2 [fn2]	Function of Output 2 Select which function will drive this output. Appears if: Always.	<input type="checkbox"/> L i m i t Limit
L S d [L.Sd]	Limit Sides Select which side or sides of the process value will be monitored. Appears if: Always.	<input type="checkbox"/> B o t h Both <input type="checkbox"/> H i g h High <input type="checkbox"/> L o w Low

13 14
15 16

To enter the Setup Menu push and hold the up and down arrow keys for approximately 3 seconds. Once there, push the green advance key to scroll through to the prompt of choice and then use the up and down arrow keys to change the range. At any point within the Operations menu to return to the default display push the Reset **RES** key.

Setup Menu

- L o C** Lockout Menu
- S E n** Sensor Type
- L i n** Linearization
- d E C** Decimal
- C _ F** Display Units
- r L o** Range low
- r h i** Range High
- F n 1** Function One
- F n 2** Function Two
- L S d** Limit Sides
- L h y** Limit Hysteresis
- A E y** Alarm Type
- A h y** Alarm Hysteresis
- A L g** Alarm Logic
- A L A** Alarm Latching
- A b L** Alarm Blocking
- A S i** Alarm Silencing
- A d S P** Alarm Display
- P A r 1** Upper or Left Display
- P A r 2** Lower or Right Display
- A d S** Zone Address

Display	Parameter Name Description	Range (Defaults are shown bold)
L h y [L.hy]	Limit Hysteresis Set the hysteresis for the limit function. This determines how far into the safe range the process value must move before the limit turns the output back on. Appears if: Always.	0.001 to 9,999.0°F or units 0.001 to 5,555.0°C Units, 3.0°F or 2°C
A E y [A.ty]	Alarm Type Select how the alarm will or will not track the set point. Appears if: Always.	<input type="checkbox"/> O f f Off <input checked="" type="checkbox"/> P r o c e s s Process Alarm
A h y [A.hy]	Alarm Hysteresis Set the hysteresis for an alarm. This determines how far into the safe region the process value needs to move before the alarm can be cleared. Appears if: When alarm type is set to process.	0.001 to 9,999.000°F or units 0.001 to 5,555.000°C Units, 1.0°F or 1.0°C
A L g [A.Lg]	Alarm Logic Select what the output condition will be during the alarm state. Appears if: Always	<input type="checkbox"/> C l o s e Close on Alarm <input type="checkbox"/> O p e n Open on alarm
A L A [A.LA]	Alarm Latching Turn alarm latching on or off. A latched alarm has to be turned off by the user. Appears if: When alarm type is set to process.	<input type="checkbox"/> N o n - L a t c h i n g Non-Latching <input type="checkbox"/> L a t c h i n g Latching
A b L [A.bL]	Alarm Blocking Select when an alarm will be blocked. After startup and/or after the set point changes, the alarm will be blocked until the process value enters the normal range. Appears if: When alarm type is set to process.	<input type="checkbox"/> O f f Off <input type="checkbox"/> S t a r t u p Startup <input type="checkbox"/> S e t P o i n t Set Point <input type="checkbox"/> B o t h Both
A S i [A.Si]	Alarm Silencing Turn alarm silencing on to allow the user to disable the output tied (configured) to this alarm Appears if: Always.	<input type="checkbox"/> O f f Off <input type="checkbox"/> O n On
A d S P [A.dSP]	Alarm Display Display an alarm message when an alarm is active. Appears if: When alarm type is set to process.	<input type="checkbox"/> O f f Off <input type="checkbox"/> O n On
P A r 1 [PAr1]	Upper or Left Display Select parameter to display. Appears if: Always.	<input type="checkbox"/> A c t i v e P r o c e s s V a l u e Active Process Value <input type="checkbox"/> n o n e none
P A r 2 [PAr2]	Lower or Right Display Select parameter to display. Appears if: Always.	<input type="checkbox"/> L i m i t S t a t e Limit State <input type="checkbox"/> A l a r m H i g h S e t P o i n t Alarm High Set Point <input type="checkbox"/> L i m i t H i g h S e t P o i n t Limit High Set Point <input type="checkbox"/> A l a r m L o w S e t P o i n t Alarm Low Set Point <input type="checkbox"/> L i m i t L o w S e t P o i n t Limit Low Set Point <input type="checkbox"/> N o n e None
A d S [Ad.S]	Zone Address - Standard Bus Communication Set zone address from 1-16. Appears if: Always.	1-16 1

Specifications

Line Voltage/Power

- All voltage levels represent minimums and maximums
85 to 264V~(ac), 47 to 63Hz
20 to 28V~(ac), +10/-15 percent; 50/60Hz, ±5 percent
12 to 40V=(dc)
10VA maximum power consumption
Data retention upon power failure via nonvolatile memory
Compliant with SEMI F47-0200, Figure R1-1 voltage sag requirements @ 24V~(ac) or higher

Environment

- 18 to 65°C (0 to 149°F) operating temperature
-40 to 85°C (-40 to 185°F) storage temperature
0 to 90 percent RH, non-condensing

Accuracy

- Calibration accuracy and sensor conformity: ±0.1 percent of span, ±1°C @ the calibrated ambient temperature and rated line voltage
Type S, 0.2 percent
Type T, below -50°C; 0.2 percent
Calibration ambient temperature @ 25°C ±3°C (77°F ±5°F)
Accuracy span: 540°C (1000°F) minimum
Temperature stability: ±0.1°C/°C (±0.1°F/°F) rise in ambient maximum

Agency Approvals

- UL@/EN 61010 Listed File E185611
UL@ 50, NEMA 4X, EN 60529 IP66 (indoor use only)
CSA C22.2 No. 24 File 158031, CE
RoHS, W.E.E.E.
FM Class 3545 File 3029084
SEMI F47-0200

Serial Communications

- Isolated communications
Standard Bus Configuration Protocol

Wiring Termination—Touch-Safe Terminals

- Input, power and controller output terminals are touch safe removable 12 to 22 AWG
Use 75°C, Cu conductor only

Universal Input

- Thermocouple, grounded or ungrounded sensors
>20MΩ input impedance
Maximum of 2KΩ source resistance
RTD 2- or 3-wire, platinum, 100Ω @ 0°C calibration to DIN curve (0.00385 Ω/Ω/°C)

- Process, 4-20mA @ 100Ω, or 0-10V=(dc) @ 20kΩ input impedance; scalable

Functional Operating Range

- Type B: -50 to 1816°C (-58 to 3301°F)
Type C: 0 to 2315°C (32 to 4199°F)
Type D: 0 to 2315°C (-328 to 4199°F)
Type E: -270 to 1000°C (-454 to 1832°F)
Type F: 0 to 1343°C (32 to 2449°F)
Type J: -210 to 1200°C (-346 to 2192°F)
Type K: -270 to 1371°C (-454 to 2500°F)
Type N: -200 to 1300°C (-328 to 2372°F)
Type R: -50 to 1767°C (-58 to 3213°F)
Type S: -50 to 1767°C (-58 to 3213°F)
Type T: -270 to 400°C (-454 to 752°F)
RTD (DIN): -200 to 800°C (-328 to 1472°F)
Process: -1999 to 9999 units

Output Hardware

- Switched dc
-22 to 32V=(dc) @ 40mA
Open collector, maximum sink current 100 mA, @ 30V=(dc)
Electromechanical relay, Form C, 5A, 24 to 240V~(ac) or 30V=(dc) maximum, resistive load, 100,000 cycles at rated load
Electromechanical relay, Form A, 5A, 24 to 240V~(ac) or 30V=(dc) maximum, resistive load, 100,000 cycles at rated load

Operator Interface

- Dual 4 digit, 7 segment LED displays
Typical display update rate 1Hz
Advance, RESET, up and down keys

Ordering Part Number

(Part number digits 1 through 14) PMXLXXX-AAABXX

All Models include: *Universal Sensor Input, Standard Bus Configuration Communications
*Dual line Red over Green 7 Segment displays

Package Size (Digit #3)

- 3 = 1/32 DIN
6 = 1/16 DIN
8 = 1/8 DIN vertical (future option)
9 = 1/8 DIN horizontal (future option)
4 = 1/4 DIN (future option)

Primary Function (Digit #4)

L = Limit Controller w/ Universal Input

Power Supply (Digit #5)

- 1 = 100-240 VAC
3 = 12-28 VAC/DC

Output 1 and 2 Hardware Options (Digits #6 and #7)

- Output 1
AJ = None
CJ = Switched dc/open collector
EJ = Mechanical Relay 5 Amp form C
Output 2
Mechanical relay 5A, Form A
Mechanical relay 5A, Form A
Mechanical relay 5A, Form A

Future Options (Digits #8 thru #11)

AAAA = None

Menu Type (Digits #12)

B = Express

Additional Options (Digits #13 and #14)

AA = Standard EZ-ZONE face plate

17 18
19 20

Declaration of Conformity

Series EZ-ZONE® PM



WATLOW
1241 Bundy Blvd.
Winona, MN 55987 USA

an ISO 9001 approved facility since 1996.

Declares that the following product:

Designation: Series EZ-ZONE® PM (Panel Mount)
Model Numbers: PM (3, 6, 8, 9 or 4)(Any Letter or number) – (1, 2, 3 or 4)(A, C, E, F or K) (A, C, H, J or K)(Any letter or number) – (Any letter or number)(A, C, E, F or K)(A, C, H, J or K) (Any three letters or numbers)
Classification: Temperature control, Installation Category II, Pollution degree 2, IP66
Rated Voltage and Frequency: 100 to 240 V~ (ac 50/60 Hz) or 15 to 36 VUdc/ 24 V~ac 50/60 Hz
Rated Power Consumption: 10 VA maximum PM3, PM6 Models. 14 VA maximum PM8, PM9, PM4 Models

Meets the essential requirements of the following European Union Directives by using the relevant standards show below to indicate compliance.

Table with 2 columns: EN 61326-1 2006 and 2004/108/EC Electromagnetic Compatibility Directive. Content includes: Electrical equipment for measurement, control and laboratory use – EMC requirements (Industrial Immunity, Class B Emissions), Electrostatic Discharge Immunity, Radiated Field Immunity 10V/M 80–1000 MHz, 3 V/M 1.4–2.7 GHz, Electrical Fast-Transient / Burst Immunity, Surge Immunity, Conducted Immunity, Voltage Dips, Short Interruptions and Voltage Variations Immunity, Harmonic Current Emissions, Voltage Fluctuations and Flicker, Specification for Semiconductor Sag Immunity Figure R1-1

For mechanical relay loads, cycle time may need to be extended up to 160 seconds to meet flicker requirements depending on load switched and source impedance.

Table with 2 columns: EN 61010-1 2001 and 2006/95/EC Low-Voltage Directive. Content includes: Safety Requirements of electrical equipment for measurement, control and laboratory use, Part 1: General requirements

Compliant with 2002/95/EC RoHS Directive

Per 2002/96/EC W.E.E.E Directive Please Recycle Properly.

Raymond D. Feller III Winona, Minnesota, USA
Name of Authorized Representative Place of Issue

General Manager June 2009
Title of Authorized Representative Date of Issue

Signature of Authorized Representative

CE DOC EZ-ZONE PM-06-09

How to Reach Us

Corporate Headquarters

Watlow Electric Manufacturing Company
12001 Lackland Road
St. Louis, MO 63146
Sales: 1-800-WATLOW2
Manufacturing Support: 1-800-4WATLOW
Email: info@watlow.com
Website: www.watlow.com
From outside the USA and Canada:
Tel: +1 (314) 878-4600
Fax: +1 (314) 878-6814

Latin America

Watlow de Mexico S.A. de C.V.
Av. Fundición No. 5
Col. Parques Industriales
Querétaro, Qro. CP-76130
Mexico
Tel: +52 442 217-6235
Fax: +52 442 217-6403

Asia and Pacific

Watlow Singapore Pte Ltd.
16 Ayer Rajah Crescent,
#06-03/04
Singapore 139965
Tel: +65 6773 9488 Fax: +65 6778 0323
Email: info@watlow.com.sg Website: www.watlow.com.sg

Watlow Australia Pty., Ltd.
4/57 Sharps Road
Tullamarine, VIC 3043
Australia
Tel: +61 3 9335 6449
Fax: +61 3 9330 3566
Website: www.watlow.com

Watlow Electric Manufacturing (Shanghai) Company
1118 Fangyuan Road, Anting Industrial Park, Jiading, Shanghai,
PRC 201203
People's Republic of China
Tel: +86 21 39509510
Fax: +86 21 5080-0906
Email: info@watlow.cn
Website: www.watlow.cn

Watlow Japan Ltd.
1-14-4 Uchikanda, Chiyoda-Ku
Tokyo 101-0047
Japan
Tel: +81-3-3518-6630 Fax: +81-3-3518-6632
Email: info@watlow.com Website: www.watlow.co.jp

Watlow Malaysia Sdn Bhd
80143 高樓市前金區七號三層189號 10樓之—
電話: 07-2885168 傳真: 07-2885568
Watlow Electric Taiwan Corporation
10F-1 No.189 Chi-Shen 2nd Road Kaohsiung 80143
Taiwan
Tel: +886-7-2885168 Fax: +886-7-2885568

Watlow Korea Co., Ltd.
#1406, E&C Dream Tower, 46, Yangpyeongdong-3ga
Yeongdeungpo-gu, Seoul 150-103
Republic of Korea
Tel: +82 (2) 2628-5770 Fax: +82 (2) 2628-5771
Website: www.watlow.co.kr

Watlow Italy S.r.l.
Viale Italia 52/54
20094 Corsico MI
Italy
Tel: +39 024588841
Fax: +39 0245869954
Email: italyinfo@watlow.com
Website: www.watlow.it

Watlow UK Ltd.
Linby Industrial Estate
Linby, Nottingham, NG15 8AA
United Kingdom
Telephone: (0) 115 964 0777
Fax: (0) 115 964 0071
Email: info@watlow.co.uk
Website: www.watlow.co.uk
From outside The United Kingdom:
Tel: +44 115 964 0777
Fax: +44 115 964 0071

Watlow Iberica, S.L.U.
C/Marie 12, Posterior, Local 9
E-28850 Torrejón de Ardoz
Madrid - Spain
T. +34 91 675 12 92
F. +34 91 648 73 80
Email: info@watlow.es
Website: www.watlow.es

Watlow UK Ltd.
Linby Industrial Estate
Linby, Nottingham, NG15 8AA
United Kingdom
Telephone: (0) 115 964 0777
Fax: (0) 115 964 0071
Email: info@watlow.co.uk
Website: www.watlow.co.uk
From outside The United Kingdom:
Tel: +44 115 964 0777
Fax: +44 115 964 0071

Watlow Korea Co., Ltd.
#1406, E&C Dream Tower, 46, Yangpyeongdong-3ga
Yeongdeungpo-gu, Seoul 150-103
Republic of Korea
Tel: +82 (2) 2628-5770 Fax: +82 (2) 2628-5771
Website: www.watlow.co.kr

Watlow Malaysia Sdn Bhd
No. 14-3 Jalan 2/114
Kuchai Business Centre
Jalan Kuchai Lama
58200 Kuala Lumpur
Malaysia
Tel: +60 3 7980 7741 Fax: +60 3 7980 7739

Watlow Electric Taiwan Corporation
10F-1 No.189 Chi-Shen 2nd Road Kaohsiung 80143
Taiwan
Tel: +886-7-2885168 Fax: +886-7-2885568

Your Authorized Watlow Distributor

