

**GENERAL**

Badger's PC100 is a versatile and easy to operate industrial process controller. Designed to interface with our complete line of industrial flow meters, it totalizes, indicates and controls fluid flows. Many years of experience in the industrial market has allowed Badger to incorporate features indispensable in the liquid batching and control operations.

The PC100 can be used as a stand alone controller or as the ideal backup to fully automated systems.

**OPERATION**

Input signals in the form of pulses from open collector transistors or dry contact closures, can be scaled to any unit of measure for totalization, instantaneous rate of flow indication and bidirectional batch counting. At the preset quantity a relay signal output can be initiated to control valves, motors, alarms, and other process control devices.

**FEATURES****Safety**

- Presettable batch limit prevents overbatching.
- Presettable time fail safe allows shutdown in case of flow signal interruption.
- Inhibit any one or combination of functions to prevent accidental operation or tampering.
- Presettable hi and lo flow alarm to detect system malfunctions.
- Quadrature count input available.
- Optional explosion proof enclosure

**Accuracy**

- Front panel scaling to compensate for meter factor or to select any unit of measure.
- Auto-adjust feature compensates automatically for valve shutdown overruns.
- Time based flow rate indication with instantaneous update.
- Up to three decimal point position for high batch resolution.

**Communications**

- Key parameters can be transmitted to printers.
- Two way serial communication allows remote monitoring and programming of key parameters by host computer.
- Up to 99 units can be connected to one host computer, each with a different ID number.
- Selectable Baud rate up to 1200.

**Flexibility**

- Count up or count down with end of batch at zero or at batch preset value.
- Presettable time between batches for auto-recycle and number of batches to be run before shutdown.
- Presettable setpoint and signal length for prewarn output to control valve's first stage, sound alarm or control injection pumps.
- Acts as stand-alone controller when central process computer system is down.
- Nonvolatile memory preserves all programmed information during power failure.
- DC input for mobile installations or backup power.
- Replaceable clear cover for dirty or contaminated environment protection available.

**Service**

- Front panel or optional enclosure provides NEMA 4X (water tight and corrosion proof) protection.
- Self test alerts of any internal failure.
- Default sets all functions to factory programmed values.
- Plug-in output relays.

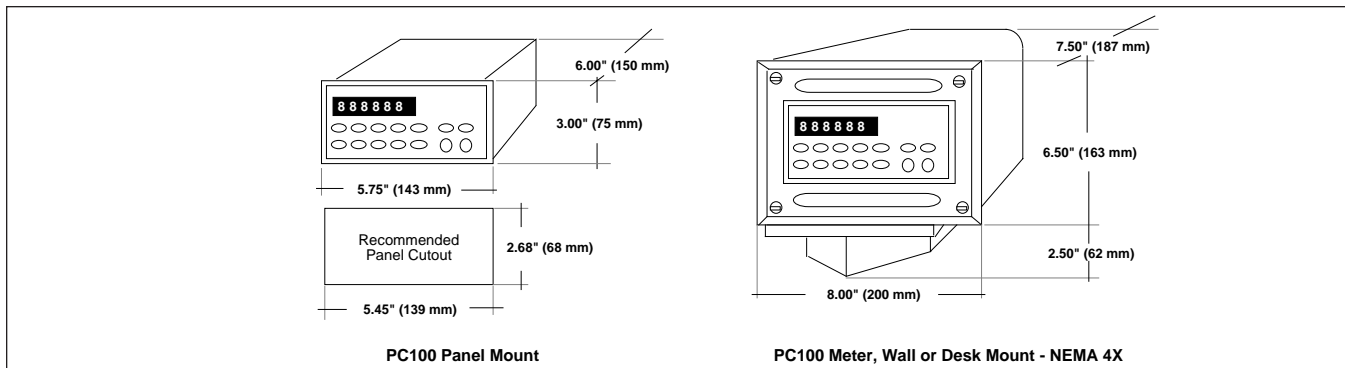

## SPECIFICATIONS

### POWER

- **AC Input Power:** 117/230 VAC, 47 to 63 Hz
- **DC Input Power:** 11 - 24 VDC
- **Consumption:** 18 watts maximum internal power supply (externally available)  
15 VDC (+1, -2) volts, 150 ma DC (only when AC powered)

### ENVIRONMENT

- **Operating Temp.:** 32° F to 130° F (0° C to 55° C)
- **Storage Temp.:** -40° F to 160° F (-40° C to 70° C)
- **Humidity:** 85% noncondensing, relative

### PHYSICAL

- **Dimensions:** See dimensional drawings
- **Weight:** 2.2 lbs. (1 Kg)
- **Materials:** High impact thermoplastics
- **Front Label:** Polyester, NEMA 4X protection

### MEMORY

- PROM, RAM, Nonvolatile NVRAM with self diagnostic capability
- **Display:** 6-digit, 7 segment, .6" high red LEDs
- **Key Pad:** Full 10 digit and 10 command keys

### INPUTS

- **Count Inputs:**
  - On AC Power:** Hi state, greater than 11.5 volts  
Low state, less than 2.5 volts  
6.8 K ohm pull up from 15 (+1, -2) volts,  
20 ma peak, 3 ma steady state  
Max. frequency of 2 Khz
  - On DC Power:** Hi state greater than DC supply minus 4 volts  
Low state, less than 2.5 volts  
6.8 K ohm pull up from DC supply,  
20 ma peak, 3 ma steady state  
Max. frequency of 2 Khz
- **Control Inputs:** Momentary switches to DC common or TTL compatible logic input:  
4750 ohms to 5 volt DC  
10 ma peak, 3 ma steady state  
**Response,** 1 ms minimum to DC common  
Start, stop, resume, reset counters, inhibit & print

## OUTPUTS

- **Relays:**
- **Type:** Form C (SPST)
- **UL/CSA Contact Ratings:**  
10 amps resistive @ 24 VDC or 240 VAC  
1/3 HP @ 120 VAC or 240 VAC  
150 VDC maximum switched voltage
- **Mechanical Life:** 5,000,000 operations
- **Electrical Life:** 100,000 operations at resistive rating
- **Transistor Outputs:**
- **Type:** Open collector NPN transistor with Zener diode transient surge protection
- **Load Voltage:** 30 VDC maximum
- **Load Current:** 300 milliamps maximum per transistor. 480 milliamps total for all transistors. Use 5 milliamps per relay coil when calculating total transistor current.

## COUNTERS/PRESETS/CONTROLS

- **Totalizer:** 10 digit resettable
- **Batch:** 6 digit programmable
- **Prewarn:** 6 digit programmable, fixed and independent of count direction, with programmable timeout of up to 99 seconds
- **Cycles:** 6 digit programmable and resettable
- **Scale Factor (Pulse Multiplier):** .0001 to 1.9999
- **Rate of Flow:** 6 digit time base, hi and low output presets. Three (3) decimal point position
- **Function Inhibit:** Inhibit all programmable functions and commands individually, with scroll up or down review. Final hard wire or key lockout.

## COMMUNICATIONS

- **Interface:** Dual port 20 ma current loop
- **Speed:** 110, 300 or 1200 Baud rate
- **Data Type:** ASCII Code
- **Format:** Start bit, 7 ASCII data bits, even parity bit, one or two stop bits
- **Information Transmitted:** Batch status, batch preset, prewarn preset, flow rate, hi and lo rate presets, totalizer, scale factor, cycle preset and cycle count
- **Information Received:** Batch preset, prewarn preset, cycle preset, hi and lo presets, scale factor, start, stop, resume and print



Please see our website at  
[www.badgermeter.com](http://www.badgermeter.com)  
for specific contacts.

Due to continuous research, product improvements and enhancements, Badger Meter reserves the right to change product or system specifications without notice, except to the extent an outstanding bid obligation exists.



**BadgerMeter, Inc.**

P.O. Box 245036, Milwaukee, WI 53224-9536  
Telephone: (414) 355-0400 / (800) 456-5023  
Fax: (414) 355-7499 / (866) 613-9305  
[www.badgermeter.com](http://www.badgermeter.com)