



UACP SERIES | GENERAL PURPOSE VALVE



1/2" metal conduit hub shown in picture



GENERAL INFORMATION

Valve Highlights

- 3/8" – 2" NPT ports
- Normally closed flow pattern
- Piston operated
- Wide temperature range capabilities

Body Materials

- Brass 3/8" – 1" port sizes
- Bronze 1-1/4" – 2" port sizes

Seal Options and Temperature Ranges

- Nitrile (BunaN): 14°F to 176°F
- EPDM: -58°F to 248°F
- Viton®: -4°F to 302°F
- PTFE: -328°F to 356°F (Steam Series)

Electrical Connection Options

- 1/2" NPT metal conduit hub with 18" leads (NEMA 2 protection class)
- 9mm din connector (NEMA 4 protection class)

Electrical Characteristics

- Standard coil class: H (Suitable for continuous duty)
- Power consumption: 14.5 watts
- DC voltages: 12, or 24
- AC voltages: 24, 120, or 240

Operating Characteristics

- Approved ambient temperature range: 14°F to 122°F

MODE OF OPERATION

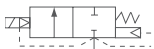

2/2 Normally Closed Solenoid Pilot Operating

See page 74 for details on modes of operations.

PORT AND ORIFICE SELECTION GUIDE

SELECTION OF PORT AND ORIFICE SIZES WITH CORRESPONDING FLOW, PRESSURE, POWER AND WEIGHT SPECIFICATIONS

PORT SIZE	ORIFICE (MM)	CV	P. MAX ¹ (PSI)	OPD ² (PSI)		WEIGHT (LBS.)
				AC COIL	DC COIL	
3/8"	16.0	3.5	725	5-150	5-150	2.8
1/2"	16.0	4.9	725	5-150	5-150	2.8
3/4"	16.0	6.3	725	5-125	5-125	2.8
1"	25.0	8.6	725	5-125	5-125	5.0
1-1/4"	30.0	20.9	725	5-125	5-125	6.8
1-1/2"	30.0	20.9	725	5-125	5-125	6.8
2"	32.0	24.5	725	5-125	5-125	11.5

¹ P. Max: The maximum pressure a valve can be subjected to without causing damage to the valve components.

² Operating Pressure Differential (OPD): The difference in pressure between the inlet and outlet ports at which the valve can safely operate. Catalog figures represent tests carried out at +/- 10% of rated voltage with ambient temperature of 80°F.

² Zero Pressure Rated (refer to OPD figures): When the lower value of OPD is zero, the valve will operate without pressure differential. Otherwise this value represents the minimum pressure differential required to operate the valve.

DIMENSIONAL DRAWINGS [INCHES]

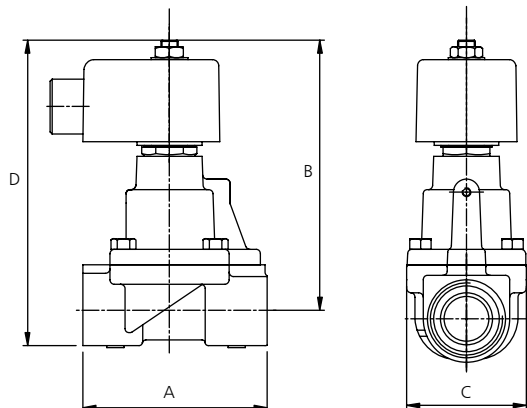

DIMENSIONAL DATA

PORT SIZE	A	B	C	D
3/8" - 3/4"	2-1/2"	4-1/8"	2-1/4"	4-13/16"
1"	4-1/4"	4-15/16"	3"	5-3/4"
1-1/4" - 1-1/2"	4-5/8"	5-1/4"	3-1/4"	8-1/4"
2"	5-3/4"	5-3/4"	4"	8-1/4"

PART NUMBER SELECTION GUIDE FOR UACP SERIES

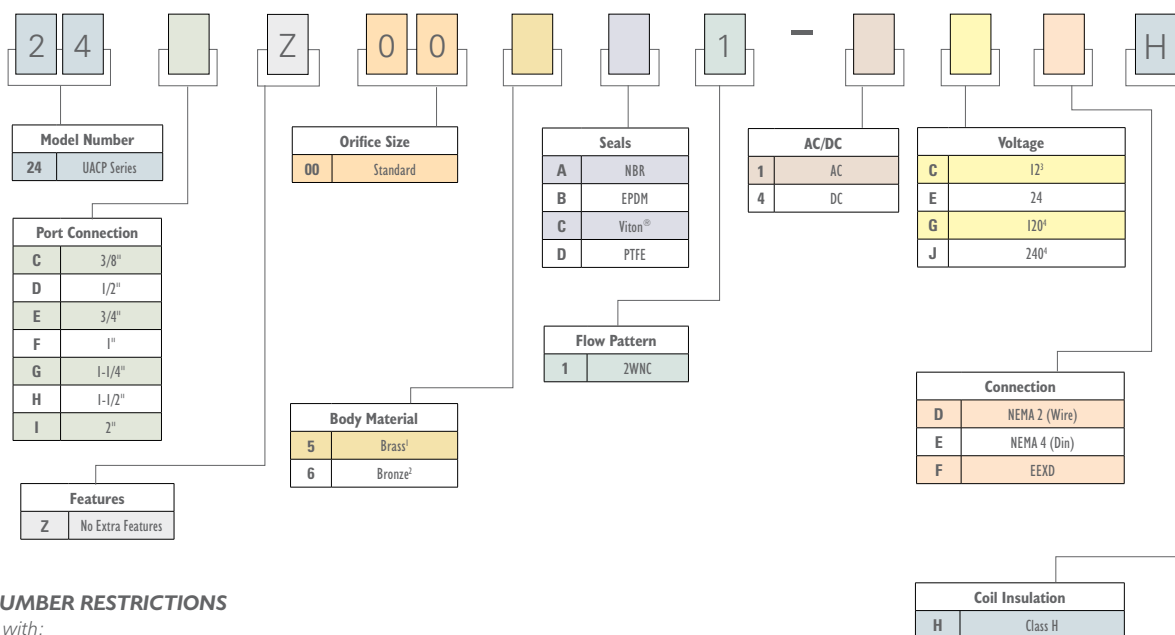

PART NUMBER RESTRICTIONS

Available with:

¹3/8", 1/2", 3/4" & 1" ports only, ²1-1/4", 1-1/2" & 2" ports only, ³DC only, ⁴AC only

STANDARD FLOW DATA

1. Select the required flow.
2. Note the corresponding pressure drop.
3. Based on the point where the two intersect, identify the most appropriate flow curve.
4. The flow curve will be labeled with a flow rate in Cv. Using the Port and Orifice Selection Guide on the left side of the page, identify the orifice size that corresponds to the desired Cv. Choose a port size that corresponds to this orifice when building the part number.

