

Rosemount 5600 Series Radar Level Transmitter

- *Market leading sensitivity and unique signal processing features allow it to handle a wide range of process conditions*
- *High repeatability ensures an extremely reliable and accurate level transmitter, even in the toughest conditions*
- *Adjustable power supply, 24-240 V AC/DC, 0-60 Hz*
- *FOUNDATION™ fieldbus or analog 4-20 mA superimposed with HART®*
- *Interchangeable transmitter heads and antennas*
- *No moving parts*
- *Non-contacting radar eliminates interaction with the product*
- *Intelligent software support for easy configuration and setup*
- *Extensive selection of antennas and materials*

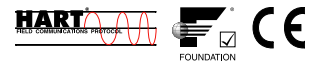

Contents

Legendary Rosemount Performance Customized For Your Level Process Applications	page 2
System Integration	page 6
Specifications	page 7
Product Certifications	page 11
Dimensional Drawings	page 13
Ordering Information	page 18
Application and Configuration Data Sheet	page 26

Legendary Rosemount Performance Customized For Your Level Process Applications

Introduction

The Rosemount 5600 Series is an intelligent non-contacting radar level transmitter. Its high performance microprocessor allows for advanced signal processing and smart echo-tracking features. Together with its high sensitivity the radar transmitter can detect and evaluate all echoes within the tank or vessel. The 5600 Series support and assist the user to a successful configuration of the transmitter in process level applications, from easy to complex process situations.

Applications

The Rosemount 5600 uses state-of-the art microwave technology to get highest reliability and precision. It measures the level of liquids, slurries, and solids. The transmitter operates in a wide range of temperatures, pressures, vapor gas mixtures, and various process conditions.

FIGURE 1. Rosemount 5600 Applications



- Applications in process vessels with agitators require a radar transmitter with the 5600's high sensitivity and advanced signal processing to separate the measuring signal from noise created by disturbances.

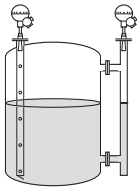

- Still-pipe or bridle mounting is recommended for LPG applications, where the surface is sometimes boiling, and for some extremely turbulent conditions. The pipe reduces foam and turbulence and also increases surface reflection.

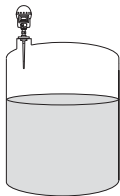

- The Rod antenna is suitable for small nozzle openings on tanks with short measuring range.

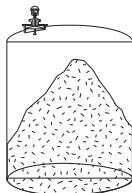

- With the parabolic antenna the 5600 Series is suitable for measurement of various types of solid materials (example: cement). Since solid materials quite often generate dusty environments inside their vessels and tanks, the parabolic antenna can be equipped with a protective PTFE cover which prevents dust from sticking to the transmitting portion of the antenna.

Product Data Sheet

00813-0100-4024, Rev FA

March 2008

Rosemount 5600 Series

Interchangeable Head

A 5600 Radar Level Transmitter consists of a Transmitter Head (TH) and a tank connection including antenna. The TH and the electronics inside are interchangeable without opening the tank.

FIGURE 2. Interchangeable Transmitter Head

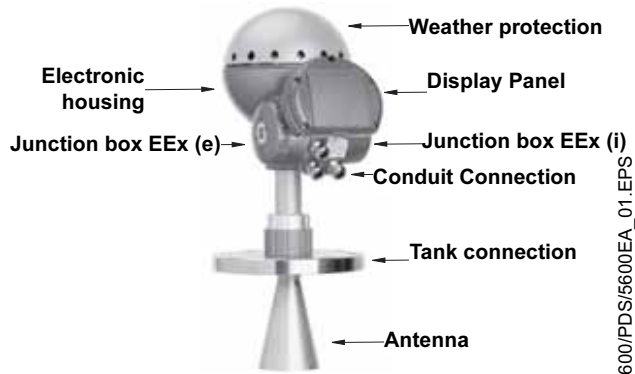

Antennas

Rod Antenna

- Suitable for tanks with small openings.
- Existing tank flange can be used as the tank connection.

Cone Antenna

- Suitable for free-propagation and pipe mounted installation.
- Cone extensions are available (see Figure 18 on page Level-16 and Table 13 on page Level-22).
- Optional Cone antennas with cleaning/flushing connection are available (see Figure 18 on page Level-16 and Table 14 on page Level-23).

Process Seal Antenna

- The dish of the Process Seal is made of PTFE.
- Only exposes material suitable for hygienic or corrosive applications (see Figure 16 on page Level-15 and Table 11 on page Level-21).

Parabolic Antenna

- Suitable for solid materials (example: cement)
- Withstand heavy contamination
- Can be equipped with a PTFE protective cover to reduce the effects of dusty environments

Plate Design

FIGURE 3. Plate Design

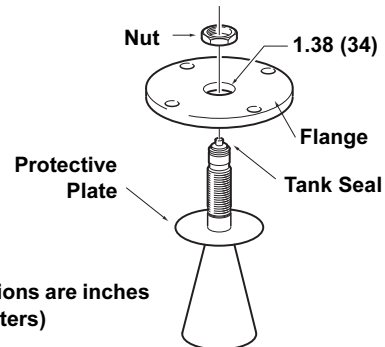

Note
Dimensions are inches
(millimeters)

Cone and Rod antennas, except the Cone with Flushing Connection, are designed with a protective plate as shown in FIGURE 3.. The plate and antenna (stainless steel or optional material) together with the tank seal and o-rings (PTFE or Quartz) are the wetted parts exposed to the tank atmosphere. This allows the use of an existing flange, or a lower cost flange alternative. Loose flanges are available (Table 18 on page Level-25).

Rosemount 2210 Display Unit

The Rosemount 2210 offers basic configuration using the 4 software keys on the display itself. Data presentation on the LCD can be customized and allows many viewing alternatives. The 2210 is also used if temperature sensors are to be connected to the 5600 Series. See Table 8 on page Level-18 for available versions.

Electrical Connections

The transmitter has a power supply with an ultra-wide input range from 24 to 240 V AC or DC, 0-60 Hz.

The Transmitter Head has two separate junction boxes. One is for a non-intrinsically safe primary signal output and power supply cables. The other is normally used for intrinsically safe (IS) HART/analog outputs or optionally for a non-IS secondary analog output.

Primary Outputs can be HART or FOUNDATION fieldbus, either IS or Non-IS. The HART and secondary analog outputs can be either active or passive depending on required options.

Mechanical Mounting

The 5600 radar transmitter is easily carried to the tank top and mounted on a suitable nozzle or pipe. The radar transmitter should be installed as follows:

- Antenna oriented perpendicular to a horizontal surface.
- The transmitter should be mounted with as few fittings as possible within the beam angle.
- Filling inlets creating turbulence should preferably be kept at a distance.
- Choose as large antenna diameter as possible. A larger diameter concentrates the radar beam and ensures maximum antenna gain. Increased antenna gain offers greater reflection of weak surface echoes.

FIGURE 4. Rosemount 5600 Beamwidth

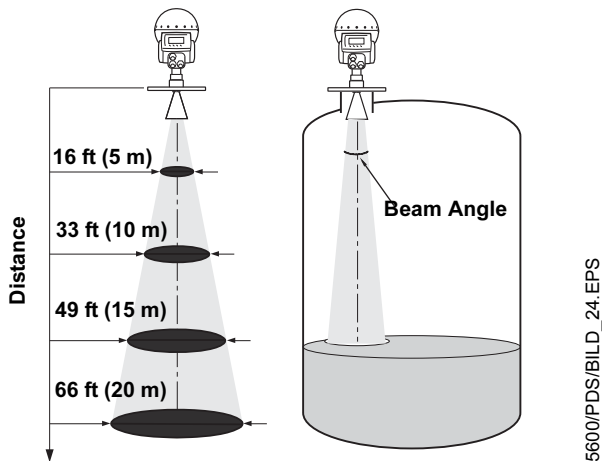
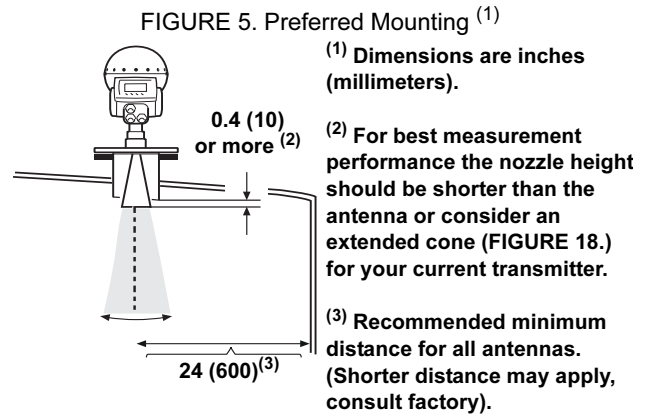

TABLE 1. Rosemount 5600 Beam Diameter and Angle

Antenna Type & Beam Angle	Distance, ft (m)			
	16 (5)	33 (10)	49 (15)	66 (20)
	Beam Diameter, ft (m)			
Cone 3 in 25°	7.2 (2.2)	14 (4.4)	22 (6.7)	29 (8.9)
Rod/Cone 4 in/ Process Seal 4 inch 21°	6.2 (1.9)	12 (3.7)	18 (5.6)	24 (7.4)
Cone 6 in/ Process Seal 6 inch 18°	5.2 (1.6)	10 (3.1)	15 (4.7)	21 (6.3)
Cone 8 inch 15°	4.3 (1.3)	8.5 (2.6)	13 (3.9)	17 (5.3)
Parabolic 10°	3.0 (0.9)	5.6 (1.7)	8.5 (2.6)	11 (3.5)



Measurement Principle

The level of the product in the tank is measured by radar signals transmitted from the antenna at the tank top. After the radar signal is reflected by the product surface the echo is picked up by the antenna. As the signal is varying in frequency the echo has a slightly different frequency compared to the signal transmitted at that moment. The difference in frequency is proportional to the distance to the product surface, and can be accurately calculated. This method is called FMCW (Frequency Modulated Continuous Wave) and is used in all high performance radar transmitters.

FIGURE 6. Frequency Modulated Continuous Wave

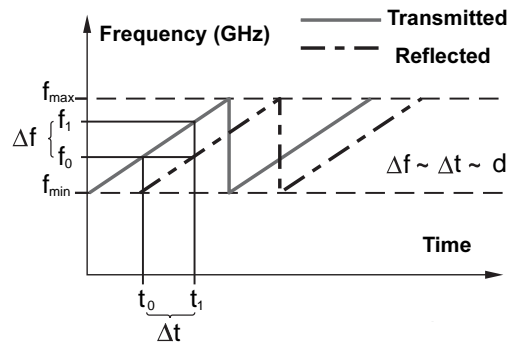

The FMCW method is based on a radar sweep with continuous changes in frequency.

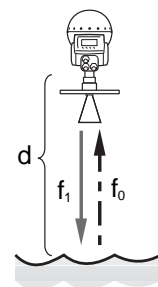

Measuring Range

The diagrams below show how the measuring range is influenced by the antenna type, dielectric constant of the liquid (ϵ_r) and the process conditions. For optimum performance the maximum measuring distance should be kept within the range indicated with darker color in the diagrams. Values are valid for free propagation measurement without still-pipes (bridles).

For liquids with ϵ_r that are smaller than 1.8 such as liquefied gases, an 8 inch or bigger diameter antenna is recommended if measurement is done with free propagation. In this case the measuring range in calm surface tanks is 50 ft (15 m).

To increase the measuring range further in turbulent tanks, a still-pipe can be used. For still-pipe mounted 5600 transmitters the typical measuring range is 115-160 ft (35-50 m) in turbulent tanks with liquids having ϵ_r less than 1.8.

The 5600 transmitter installed in a pipe can measure products with a dielectric ≥ 1.4 .

TABLE 2. Categories of liquids	
a	Oil, gasoline and other hydrocarbons, petrochemicals (dielectric constant, $\epsilon_r=1.9-4.0$)
b	Alcohols, concentrated acids, organic solvents, oil/water mixtures and acetone ($\epsilon_r=4.0-10$)
c	Conductive liquids, e.g. water based solutions, dilute acids and alkalis ($\epsilon_r > 10$)

FIGURE 7. Applications with calm product surface⁽¹⁾

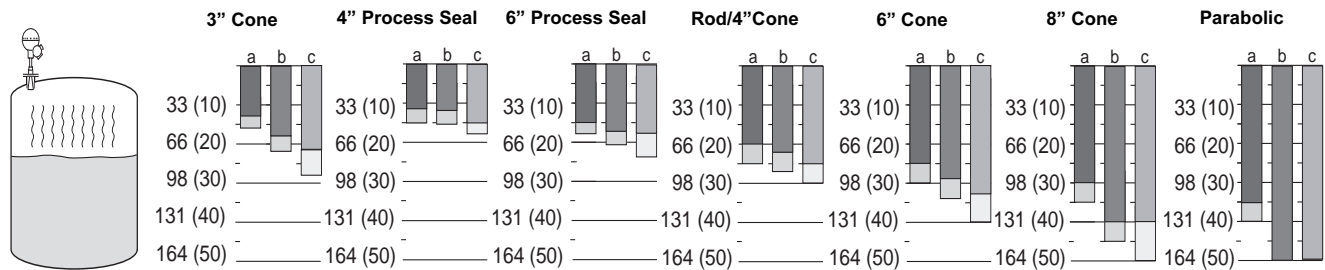

FIGURE 8. Applications where the product is gently stirred, causing minor turbulence⁽¹⁾

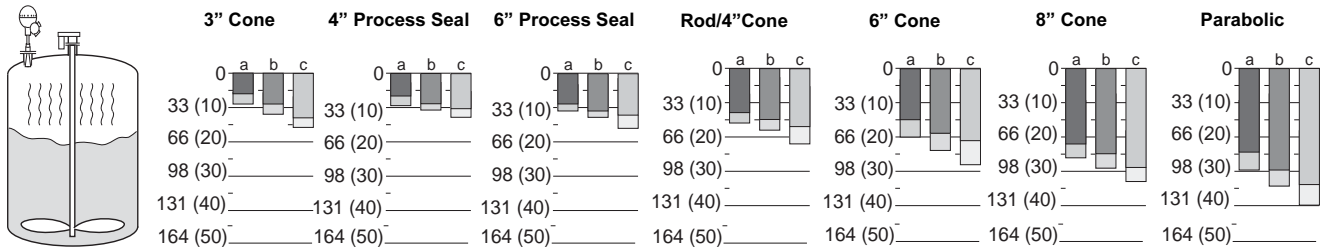
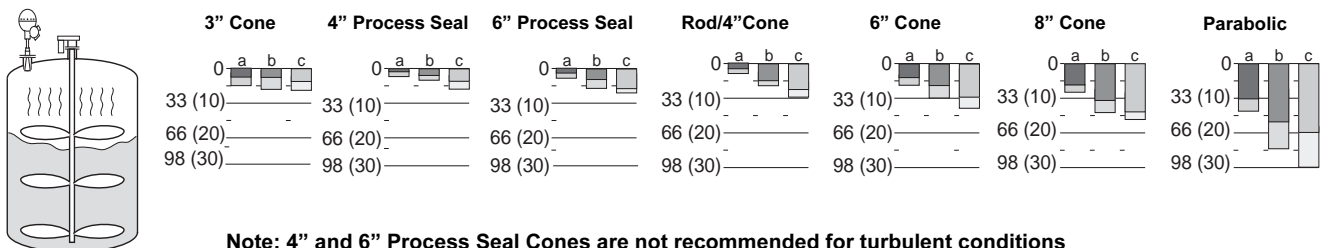

FIGURE 9. Applications with turbulent product surface conditions⁽¹⁾



(1) Measuring range in ft (m).

System Integration

Level values are transmitted from the transmitter as analog 4-20 mA signals superimposed with HART or FOUNDATION™ fieldbus. The analog outputs are either passive for connection to powered cables or active providing signal power for 4-20 mA. Analog outputs can also be specified as intrinsically safe or non-intrinsically safe.

Basic configuration and setup can be done on a HART communicator, via the 2210 Display Unit, AMS, DeltaV, or any other FOUNDATION fieldbus/HART host applications (control systems).

Rosemount Radar Master is a PC based software package which allows for full configuration, including advanced features such as Spectra plots, offline/online configuration capabilities, logging, extensive online help, etcetera. To communicate with the device using Radar Master either a HART or Modbus Modem (RS485 Sensor Bus Port) is required for the PC. For fieldbus devices Radar Master can only be connected to the Sensor Bus Port (see list of Modems on page 25).



The Rosemount 5600 is a core component of the PlantWeb digital plant architecture.

FIGURE 10. System Integration using the HART Communicator

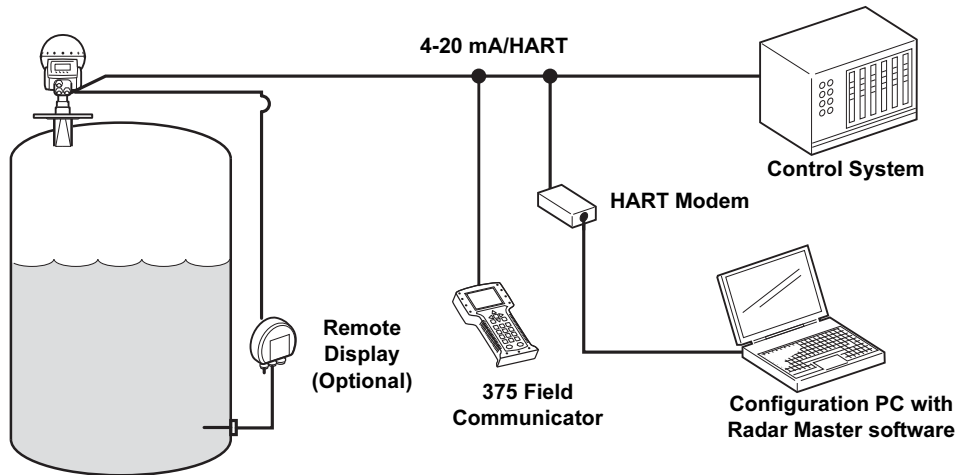
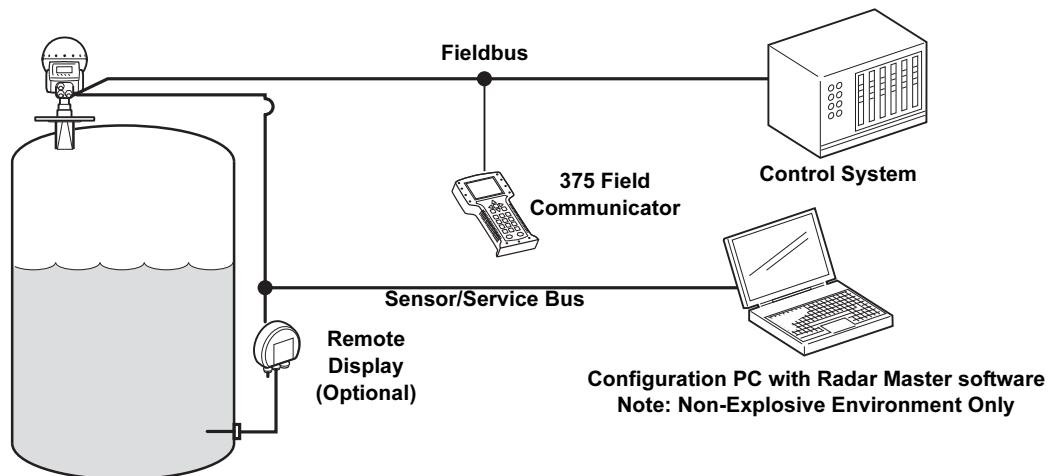

FIGURE 11. System Integration FOUNDATION fieldbus



Specifications

GENERAL

Product Designation

5600 Series Radar Level Transmitter

Operating Principle

10GHz FMCW radar

Beam Angle

See Figure 2-12. and Table 2-3 on page 2-9

Microwave Output Power

Max 1.0 mW

Internal Calibration

Internal digital reference for automatic compensation of radar sweep

Signal Processing

Powerful and advanced digital signal processing using FFT and advanced echo handling software

MEASURING PERFORMANCE

Instrument Accuracy (Under reference conditions)

±0.2 in. (±5 mm)

Reference Conditions

Metal plate with no disturbing objects

Temperature: 68 °F (20 °C).

Pressure: 14 - 15 psi (960 - 1060 mbar).

Humidity: 25 - 75% RH.

Reference Measuring Range: 1.64 - 98 ft. (0.5 - 30 m)

Resolution

0.04 in (1 mm)

Temperature Stability

±500 ppm of measured distance within the ambient temperature range

Repeatability

±0.04 in (±1 mm)

Measuring Range

0-164 ft. (0-50 m) Standard

0 - 324 ft. (0 - 99 m) Optional, requires special configuration

Update Time

100 ms

Processors

32-bit Floating DSP

CONFIGURATION

HART Device

Configure the device using Rosemount Radar Master, a powerful and interactive Windows-based configuration tool, which is enclosed with each order. A HART Modem is required for the PC to communicate with the device.

Recommended PC Hardware Specification: ≥ 1 GHz processor, ≥ 128 MbRam, and Operating System of Windows 2000, XP, or NT.

Alternative Configuration Tools:

Emerson Process Management 375 Field Communicator, Emerson Process Management AMS software, or many of the other HART hosts that supports DD technology.

FOUNDATION™ fieldbus Device

Configuration of a fieldbus device can be done via DeltaV, or the 375 Field Communicator, or by hosts that support FOUNDATION™ fieldbus and DD technology.

Radar Master may also be used for 5600 fieldbus devices, but only using the Sensor Bus Port connection. See below.

Sensor Bus Port

Configuration is also available with Radar Master via the 5600 device Sensor Bus Port Connection. This port is available for both HART and Fieldbus devices. Connect the PC directly to the transmitter using a RS485 (Modbus) modem.

Note that this connection is only allowed in a Non-Explosive environment. See Figure 11 on page Level-6. A proven RS485 Modem and the part number is listed in Table 17 on page Level-25.

DISPLAY

Display (factory mounted on transmitter)

Protection class IP67

With weather/dirt protection cover; graphical LCD display 128 by 64 pixels with 4 control soft-keys and 7 text lines with 16 characters/line for display and configuration.

Display (remote mounted)

Same as above, mounted in separate enclosure, protection class IP67; max cable length, display - radar transmitter: 330 ft. (100 m); cable type: 4 wire shielded instrument cable, min. 0.5 mm², (AWG 20).

Display with Temperature Inputs (remote mounted)

Same as above, mounted in separate enclosure, protection class IP67; max cable length, display - radar transmitter: 330 ft. (100 m); cable type: 4 wire shielded instrument cable, min. 0.5 mm², (AWG 20); temperature measurement 1-3 spot elements PT100 or CU100, or 6 spot elements with common return.

ELECTRICAL

Power Supply

Ultra wide power supply 24-240 V AC or DC 0-60 Hz

NOTE

Minimum power required at transmitter power terminals is 20 V

Power Consumption

Maximum 10 W, Nominal 5 W

Transmitter Cable Entries

3 × 1/2 inch NPT; for cable glands or conduit entries

Optional: 1/2 inch NPT Cable Gland Kit

Optional: 1/2 inch NPT/ M20 Adapters (Set of 3)

Remote 2210 Display Unit Cable Entries

2x M20 Entries

1x M25 Entry

Output Cabling

Twisted and shielded pair; min. 0.5 mm² (AWG 20)

Outputs

Primary Output:

Alternative 1: HART[®] + 4-20 mA current loop
(non-IS or IS option)

Alternative 2: FOUNDATION[™] fieldbus (non-IS or IS option)

Secondary Outputs:

Analog 4-20 mA current loop (Optional)

Analog Output Characteristics

Type

Analog 4-20 mA Current Loop, active (with power supplied by the 5600) or passive (for loop-supplied power)

Galvanic Isolation

> 1500 V RMS or DC

Analog Output Characteristics

See Product Certifications on page Level-11

Alarm Level

Standard: Low=3.8 mA, High=22 mA or freeze,

NAMUR NE43: High=22.50 mA,

Rosemount: Low=3.75 mA

Accuracy

±300 µA at 4 mA

±600 µA at 20mA

Resolution

0.5µA (0.003%)

Linearity

±0.01%

Temperature Drift

± 28 ppm/°F (±50 ppm/°C)

Output Impedance

>10 MΩ

Voltage Compliance

7-30 V (passive output)

External Loop Resistance

<700 Ω (passive output with 24 V external supply)

<300 Ω (active output)

Fieldbus Output Characteristics

Fieldbus Voltage limits: 9 to 32 V

Current Draw: 12.5 mA

For I.S. Applications:

U_i = 30 V

I_i = 300 mA

P_i = 1.3 W

C_i = 0

L_i = 0

Lift-off Minimum Voltage

9.0 V

Class

Link Master (LAS)

Number of Available VCRs

20

VCR Statistics

Yes

Execution Time

60 ms for AI-block

Instantiation

No (all blocks are instantiated per default)

Available Menus and Methods

Transducer Block

Configure Gauge, Restart Device, Set to Factory Defaults, Sensor Bus

Resource Function Block

Master Reset

Conforming FOUNDATION Fieldbus

ITK 4.6

Product Data Sheet

00813-0100-4024, Rev FA

March 2008

Rosemount 5600 Series

Advanced Diagnostics

Failures

Level, Temperature and Volume measurement failure

Warnings

Empty tank, full tank, Database, Hardware, Software, and Configuration warnings

Errors

Database, Hardware, Software, and Configuration warnings

2210 Display Unit Output Characteristics

With Temperature Output

See Product Certifications on page Level-11

Without Temperature Output

See Product Certifications on page Level-11

Temperature Measurement

1-3 spot elements, PT100 or CU100, or 6 spot elements with common return. Input accuracy $\pm 0.9^{\circ}\text{F}$ ($\pm 0.5^{\circ}\text{C}$)

Temperature Measurement Output

Average temperature or individual spots ⁽¹⁾

(1) Individual spots not available in Foundation fieldbus devices

TABLE 4. Antenna material and o-ring selection ● Applicable - Not applicable

*The Rod antenna is a combination of 316L SST and PTFE.

	Rod Antenna	Cone Antenna	Process Seal Antenna	Extended Cone Antenna	Cone with Integrated Flushing Connection	Parabolic Antenna
Material:						
Stainless Steel 316L	●	●	-	●	●	●
Hastelloy® C22	-	●	-	-	-	-
Titanium Gr1/Gr2	-	●	-	-	-	-
Tantalum	-	●	-	-	-	-
Monel® 400	-	●	-	-	-	-
PTFE	●	-	●	-	-	-
Tank Seal:						
PTFE	-	●	-	●	●	●
Quartz	-	●	-	●	●	-
O-Rings:						
Viton®	●	●	-	●	●	●
Fluoroelastomer						
Kalrez® 6375	●	●	-	●	●	-
EPDM	●	●	-	●	●	-
Buna-N	●	●	-	●	●	-

MECHANICAL

Housing/Enclosure

Permanent moulded cast aluminium, chromed and powder painted

Flanges

ANSI, DIN standard,

Material: Stainless steel 316L and Stainless Steel EN 1.4404

Approximate Weights

TABLE 3.

Transmitter	Size in. (mm)	Weight lb. (kg)
5600 Transmitter	N/A	19.8 lbs. (9,0 kg)
Antenna	Size in. (mm)	Add Max lb. (kg)
Rod Antenna		4.41 lb. (2,0 kg)
Cone Antenna	3 in. (76,2 mm)	2.20 lb. (1,0 kg)
Cone Antenna	4 in. (101,6 mm)	3.31 lb. (1,5 kg.)
Cone Antenna	6 in. (152,4 mm)	4.41 lb. (2,0 kg.)
Cone Antenna	8 in. (203,2 mm)	6.61 lb. (3,0 kg.)
Process Seal Antenna	PS 4 in. (101,6 mm)	4.41 lb. (2,5 kg.)
Process Seal Antenna	PS 6 in. (152,4 mm)	5.51 lb. (2,5 kg.)
Parabolic Antenna		17.6 lb. (8,0 kg.)

Height Above Flange

15 in (400 mm)

Antenna Dimensions

Cone: See Figure 13 on page Level-14

Rod: See Figure 12 on page Level-13

Process Seal: See FIGURE 16. and Table 7 on page Level-15

Extended Cone: See page 16

Cone with Integrated Flushing Connection:

See page 16

Parabolic: See Figure 19 on page Level-17

Rosemount 5600 Series

ENVIRONMENTAL

Ambient Temperature

-40 to 70°C (-40 to 158°F)

LCD Readable between: -20 to 70 °C (-4 to 158 °F)

Process Temperature Range ⁽¹⁾

-40 to 752°F (-40 to 400°C)

Flange Temperature Range ⁽¹⁾

TABLE 5. Flange Temperature Range depending on O-ring selection

O-ring Material	Minimum Temperature °F (°C) in air	Maximum Temperature F (°C) in air
Viton [®] Fluoroelastomer	5 (-15)	392 (200)
Ethylene Propylene (EPDM)	-40 (-40)	266 (130)
Kalrez [®] 6375	-4 (-20)	527 (275)
Buna-N	-31 (-35)	230 (110)

Pressure Range ⁽¹⁾

Full vacuum to +798 psig (+55 bar), depending on antenna style

Emission Approvals

FCC: K8CPRO, K8CPROX

R&TTE: E813268O-CC

Humidity

IEC 60068-2-3

Climatic Class/Corrosion Class

IEC 68-2-1, IEC 60068-2-52 test KB severity 2

Ingress Protection

IP66, IP 67, and NEMA 4

Vibration

IEC 721-3-4 class 4M4

UV Protection

ISO 4892-2

Electromagnetic Compatibility

EN61326-1: 1997 incl A1:1998 and A2:2001, Immunity 50081-2, Emission 50081-1

Lightning Protection

EN61326, EN61000-4-5, IEC801-5, level 2 kV

Power Supply Fluctuation

IEC 92 Part 504 sec. 3.5

(1) See FIGURE 12., FIGURE 13., FIGURE 16., FIGURE 17., FIGURE 18., and FIGURE 19. for specification of each antenna.

Product Certifications

SAFETY NOTE AND SPECIAL CONDITIONS FOR SAFE USE (X-MARKINGS IN ATEX, AND IEC EX CERTIFICATES)

As light alloys may be used as the enclosure (or other parts) they may be at the accessible surface of this equipment, in the event of rare incidents, ignitions sources due to impact and friction sparks could occur. This shall be considered when the equipment is being installed in locations that specifically require Group II, Category 1G equipment.

Under certain extreme circumstances, the non-metallic parts of the equipment may be capable of generating an ignition-capable level or electrostatic charge. Therefore, when used for applications that specifically require Group II, Category 1 equipment, the equipment shall not be installed in a location where the external conditions are conducive to the build-up of electrostatic charge on such surfaces. Additionally, the equipment non-metallic parts shall only be cleaned with a damp cloth

Approved Manufacturing Locations

Rosemount Tank Radar AB – Gothenburg, Sweden

European Union Directive Information

The EC declaration of conformity for all applicable European directives for this product can be found on the Rosemount website at www.rosemount.com. A hard copy may be obtained by contacting our local sales representative.

ATEX Directive (94/9/EC)

Rosemount Inc. complies with the ATEX Directive.

Ordinary Location Certification for Factory Mutual

As standard, the transmitter has been examined and tested to determine that the design meets basic electrical, mechanical, and fire protection requirements by FM, a nationally recognized testing laboratory (NRTL) as accredited by the Federal Occupational Safety and Health Administration (OSHA).

5600 Series Radar Level Transmitter European ATEX Directive Information

This document lists specific requirements which have to be fulfilled to secure a safe installation and use of 5600 Series Radar Level Transmitter in a hazardous area. Omission may jeopardize safety, and Rosemount will not take any responsibility if requirements as listed below are not fulfilled.



Canadian Registration Number (CRN)

The product design of the Cone Antenna has been accepted and registered for use in Canada.
CRN: 0F1015.9C

Hazardous Locations Certifications

ATEX Approvals

5600 Series Level Transmitter

- E1** Certificate Number: Sira 03ATEX1294X
With Intrinsically Safe Outputs (only)
ATEX Marking:  II (2) (1) 1/2 GD T85°C
Safety Coding: EEx de [ib] [ia] IIC T6 (-40°C ≤ T_{amb} ≤ +70°C)
With Non-IS Primary Output and IS Display Output
ATEX Marking:  II (1) 1/2 GD T85°C
Safety Coding: EEx de [ia] IIC T6 (-40°C ≤ T_{amb} ≤ +70°C)
With Non-IS Primary and/or Non-IS Secondary Outputs
ATEX Marking:  II 1/2 GD T85°C
Safety Coding: EEx de IIC T6 (-40°C ≤ T_{amb} ≤ +70°C)
Special Conditions for Safe Use: See first paragraph of the Produce Certifications Chapter

Passive analog output 4-20mA,
Label identification = HART passive.

Voltage compliance 7-30V:

U_i = 30 V
I_i = 200 mA
C_i = 0
L_i = 0
U_o = 0
I_o = 0
U_m = 250 V

Active analog output 4-20mA,
Label identification = HART active.



Max load 300Ω:

U_o = 23.1 V
I_o = 125.7 mA
P_o = 0.726 W
C_{ext} = 0.14 μF
L_{ext} = 2.2 mH
C_i = 0
L_i = 0

FOUNDATION Fieldbus,
Label identification = FOUNDATION fieldbus.

U_i = 30 V
I_i = 300 mA
P_i = 1.3 W
C_i = 0
L_i = 0

2210 Display Unit

- Certificate Number: Sira 00ATEX2062
Without Temperature Inputs
ATEX Marking:  II 2 G
Safety Coding: EEx ib IIC T4 (-40°C ≤ T_{amb} ≤ +70°C)
With Temperature Inputs
ATEX Marking:  II 2 (1) G
Safety Coding: EEx ib [ia] IIC T4 (-40°C ≤ T_{amb} ≤ +70°C)

Factory Mutual (FM) Approvals

5600 Series Level Transmitter

- E5** Certificate Number: 4D5A9.AX
With Intrinsically safe outputs
 (all versions except those listed below)
 Explosion proof with IS outputs for HAZLOC
 Class I, Division 1, Group A, B, C and D, T6
 Max operating temperature +70°C
 Dust ignition proof for use in Class II/III, Division 1, Groups E, F, and G, T5.
 Use conductors rated at least 85°C
 Shall be installed in accordance with System control drawing 9150074-994.
- With Non-IS Secondary Outputs (codes 1 and 3)**
 Explosion proof
 Class I, Division 1, Group A, B, C and D, T6
 Max operating temperature +70°C
 Dust ignition proof for use in Class II/III, Division 1, Groups E, F, and G, T5.
 Use conductors rated at least 85°C

2210 Display Unit

- Certificate Number: 3008356
All Versions
 Intrinsic Safe for HAZLOC
 Class I, Division 1, Group A, B, C and D T4
 Max operating temperature +70°C
 Shall be installed in accordance with System control drawing 9150074-997.

Canadian Standards Association (CSA Approvals)

5600 Series Level Transmitter

- E6** Certificate Number: 2003.153280-1346169
With Non-IS Primary and/or Secondary Outputs
 Explosion proof Ex de IIC T6
 Shall be installed in accordance with System control drawing 9150074-937.
 Factory seal, conduit seal not required.
- With IS Display Outputs, IS Primary and/or Secondary Outputs**
 Explosion proof Ex de [ib/ia] IIC T6
 Shall be installed in accordance with System control drawing 9150074-939.
 Factory seal, conduit seal not required.

2210 Display Unit

- Certificate Number: 2003.153280-1346165
Without Temperature Inputs
 Intrinsically safe EEx ib IIC T4 (-40°C ≤ T_{amb} ≤ +70°C) With Temperature Inputs
 Intrinsically safe EEx ib [ia] IIC T4 (-40°C ≤ T_{amb} ≤ +70°C)
 Shall be installed in accordance with System control drawing 9150074-944.

IECEX Approvals

5600 Series Level Transmitter

- E7** Certificate Number: IECEx SIR 05.0024X
With Intrinsically Safe Outputs (only)
 Safety Coding: Ex de [ib] [ia] IIC T6 tD A20 IP65 T85 °C (-40°C ≤ T_{amb} ≤ +70°C)
With Non-IS Primary Output and IS Display Output
 Safety Coding: Ex de [ia] IIC T6 tD A20 IP65 T85 °C (-40°C ≤ T_{amb} ≤ +70°C)
With Non-IS Primary and/or Non-IS Secondary Outputs
 Safety Coding: Ex de IIC T6 tD A20 IP65 T85 °C (-40°C ≤ T_{amb} ≤ +70°C)
- Passive analog output 4-20mA,
 Label identification = HART® passive.
 Voltage compliance 7-30V:
 U_i = 30 V
 I_i = 200 mA
 C_i = 0
 L_i = 0
 U_o = 0
 I_o = 0
 U_m = 250 V rms

- Active analog output 4-20mA,
 Label identification = HART® active.
 Max load 300Ω:
 U_o = 23.1 V
 I_o = 125.7 mA
 P_o = 0.726 W
 C_o = 0.14 μF
 L_o = 2.2 mH
 C_i = 0
 L_i = 0

- FOUNDATION™ Fieldbus,
 Label identification = FOUNDATION™ fieldbus.
 U_i = 30 V
 I_i = 300 mA
 P_i = 1.3 W
 C_i = 0
 L_i = 0
 Conditions of Certification: See first paragraph of the Produce Certifications Chapter

2210 Display Unit

- Certificate Number: IECEx SIR 05.0021
Without Temperature Inputs
 Safety Coding: Ex ib IIC T4 (-40°C ≤ T_{amb} ≤ +70°C)
With Temperature Inputs
 Safety Coding: Ex ib [ia] IIC T4 (-40°C ≤ T_{amb} ≤ +70°C)

Dimensional Drawings

FIGURE 12. Rod Antenna Dimensions

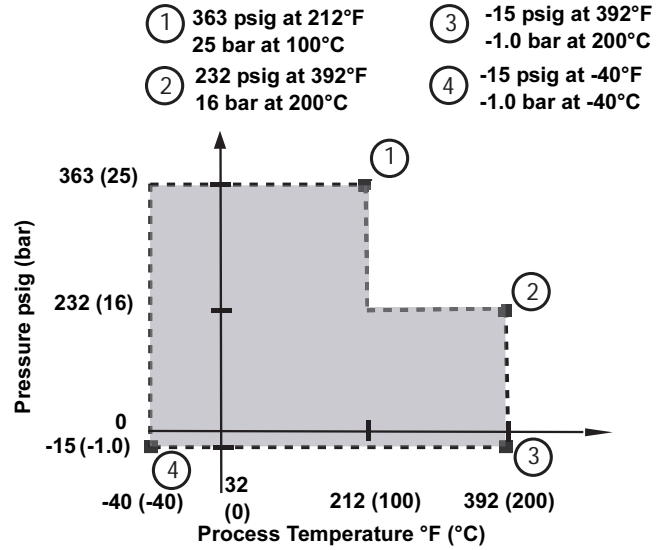
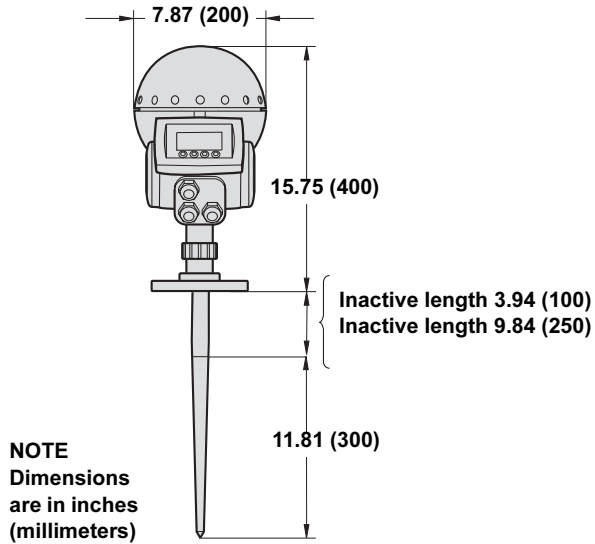

Note: Pressure rating may be lower depending on flange selection.
 Minimum / maximum flange temperature rating depends on O-ring selection (See Table 6 and page 14).

FIGURE 13. Cone Dimensions

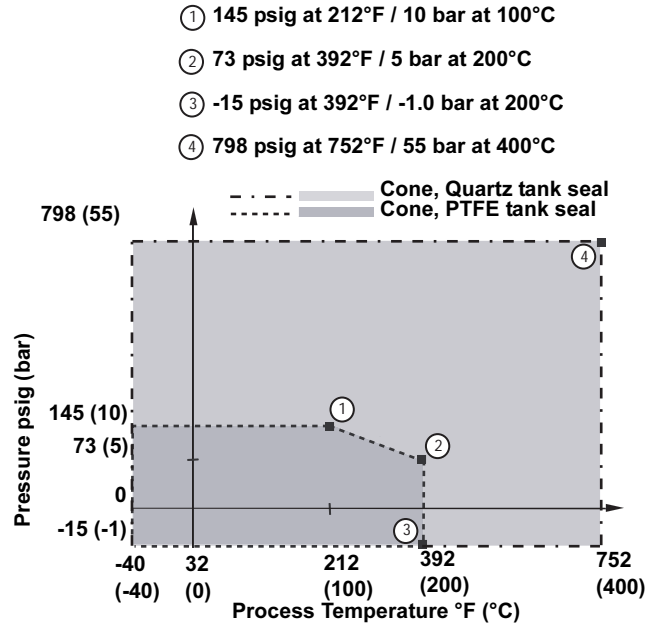
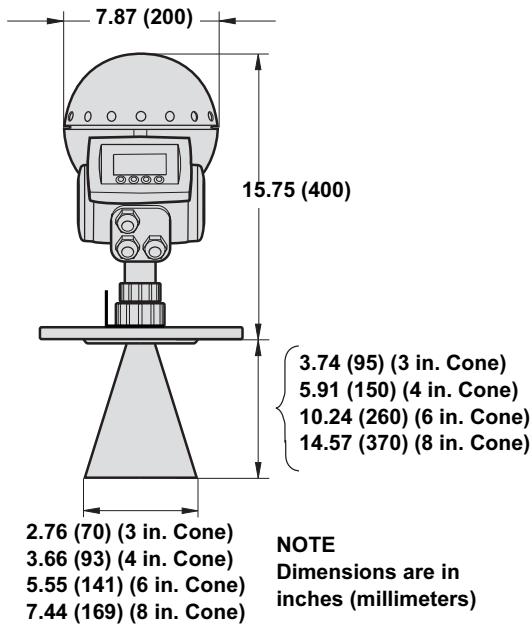

Note: Pressure rating may be lower depending on flange selection.

Minimum / maximum flange temperature rating depends on O-ring selection (See Table 6 and FIGURE 14.).

TABLE 6. Flange Temperature Range depending on O-ring selection

O-ring Material	Minimum Temperature °F (°C) in air	Maximum Temperature F (°C) in air
Viton®	5 (-15)	392 (200)
Fluoroelastomer		
Ethylene Propylene (EPDM)	-40 (-40)	266 (130)
Kalrez® 6375	-4 (-20)	527 (275)
Buna-N	-31 (-35)	230 (110)

FIGURE 14. Temperature Rating Considerations

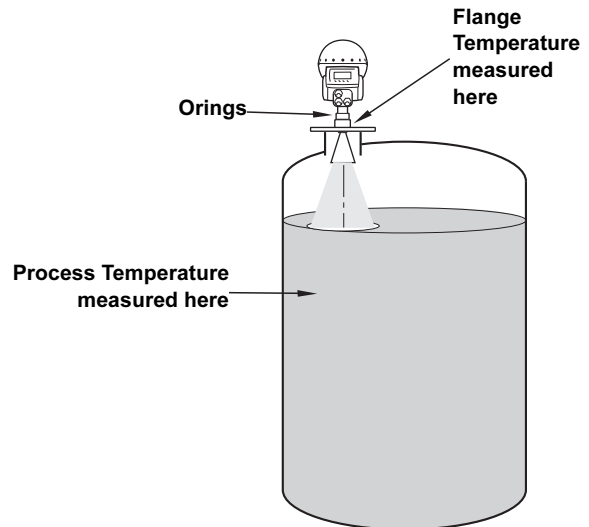

Note
Flange temperature depends on mounting conditions, such as nozzle position, distance to max product level, nozzle height, presence of insulation, etc.

FIGURE 15.

FIGURE 16. Process Seal Antenna Dimensions

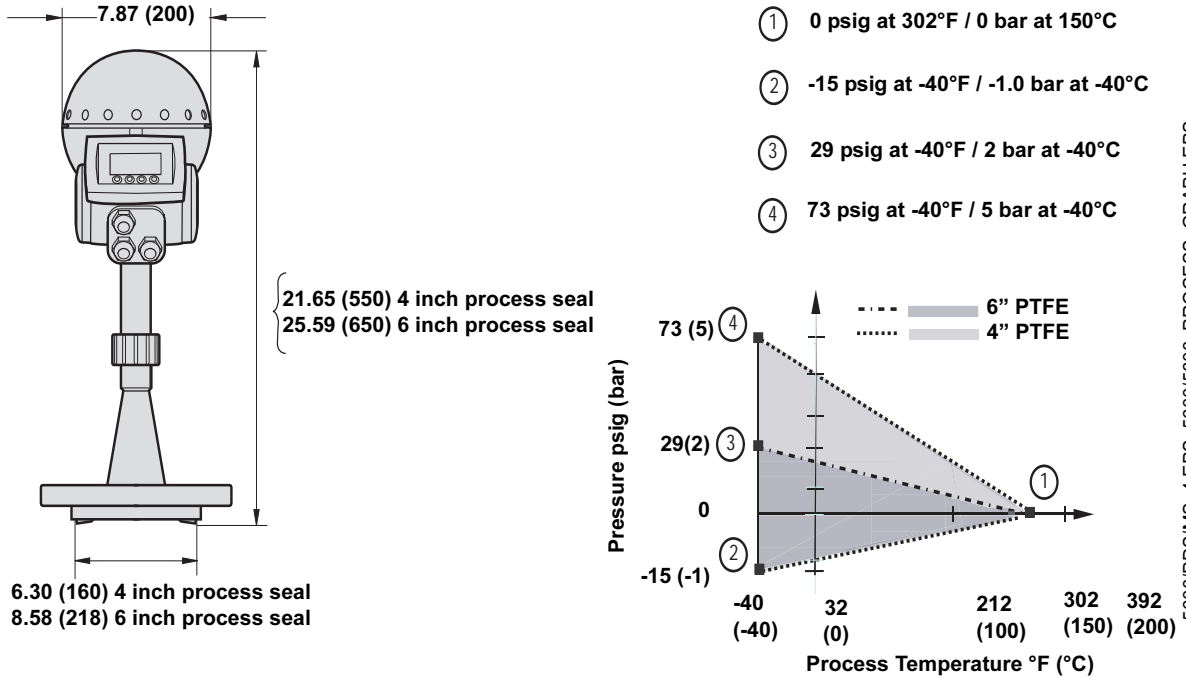

5600/PDS/MS_4.EPS, 5600/5600_PROCESS_GRAPH.EPS

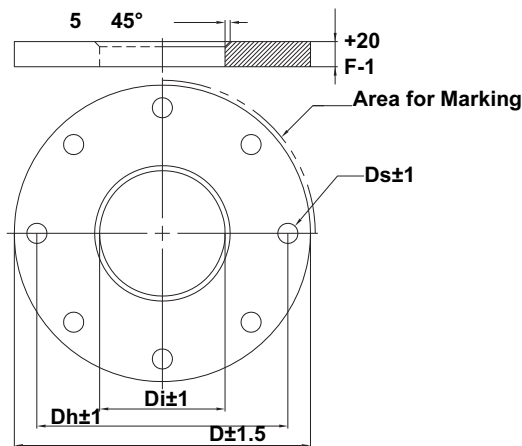

5600_D.D_9150070836AA

Note
 Dimensions are in
 inches (millimeters)

TABLE 7. Dimensions for Stainless Steel Flange and Galvanized Carbon Steel Dimensions are in inches (millimeters)

Flange	Di	D	Dh	Ds	F
ANSI 4 inch Class 150	3.78 (96)	9.02 (229)	7.52 (191)	0.87 (22)	0.87 (22)
ANSI 6 inch Class 150	4.94 (125.5)	10.98 (279)	9.49 (241)	0.87 (22)	0.87 (22)
DN100 PN16	3.78 (96)	8.66 (220)	7.09 (180)	0.71 (18)	0.87 (22)
DN150 PN16	4.94 (125.5)	11.22 (285)	9.45 (240)	0.87 (22)	0.87 (22)

FIGURE 17. Extended Cone Antenna Dimensions

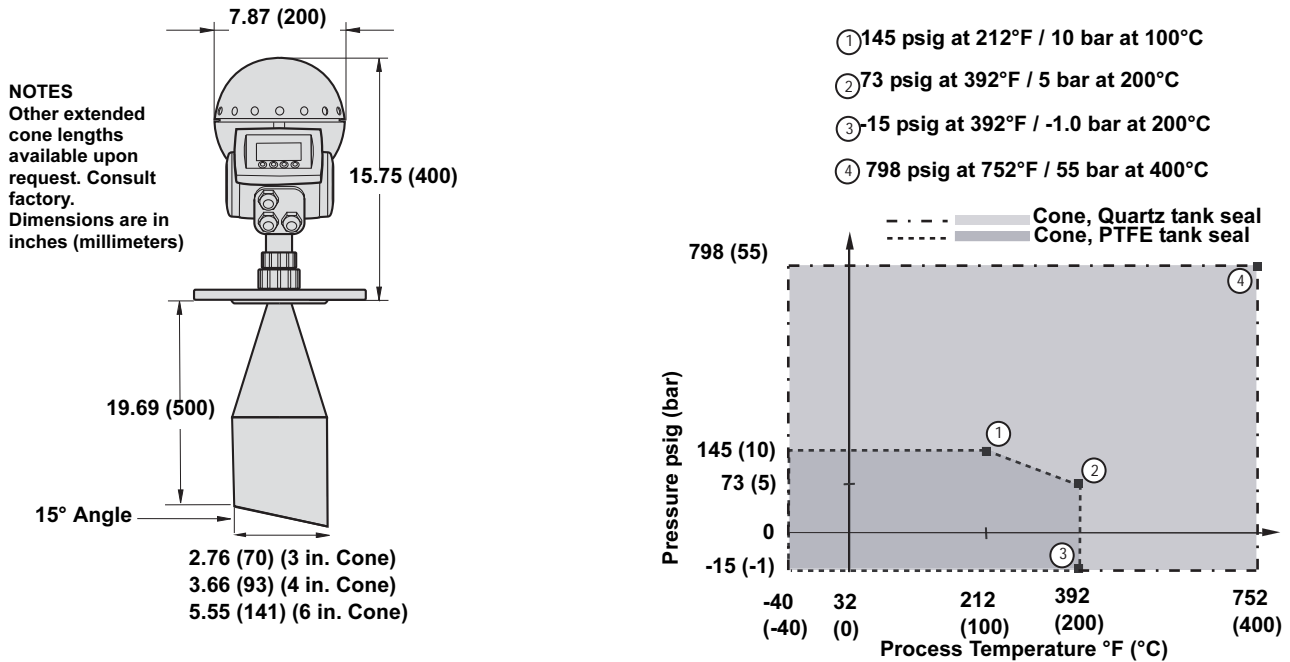

Note: Pressure rating may be lower depending on flange selection.
Minimum / maximum flange temperature rating depends on O-ring selection (See Table 6 and page 14).

FIGURE 18. Cone Antenna with Integrated Flushing Connection Dimensions

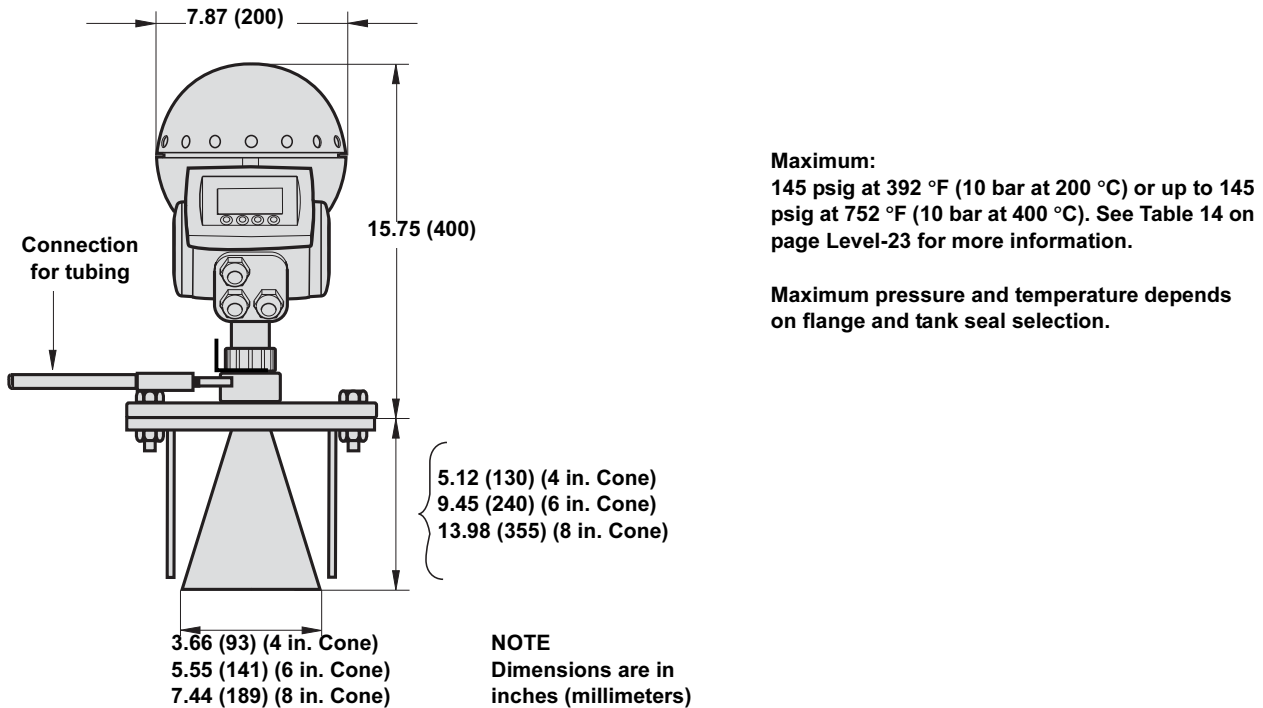

Note: Pressure rating may be lower depending on flange selection.
Minimum / maximum flange temperature rating depends on O-ring selection (See Table 6 and page 14).

FIGURE 19. Parabolic Antenna Dimensions

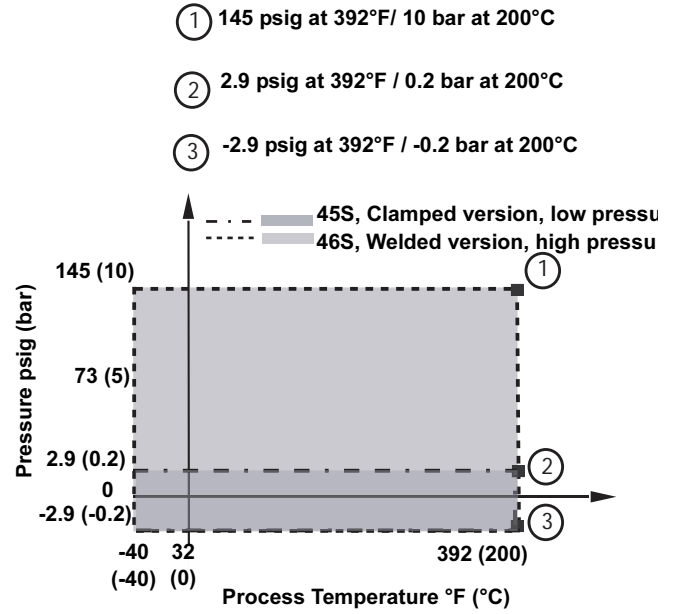
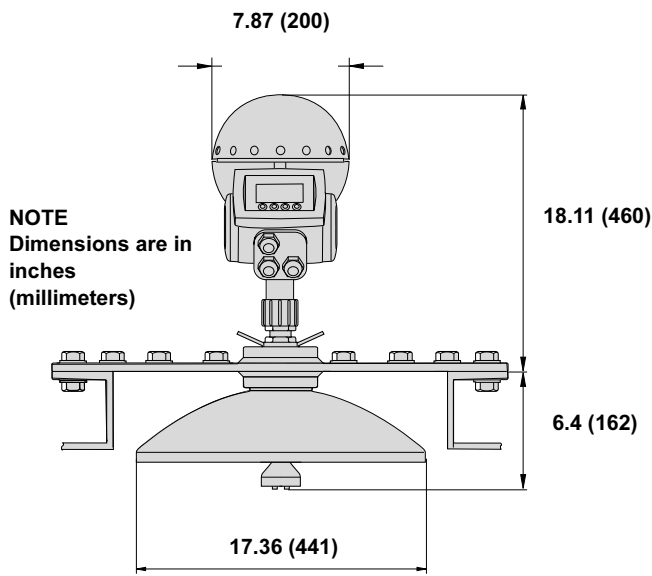

Ordering Information

TABLE 8. Rosemount 5600 Radar Transmitter Selection

Model	Product Description
5601	Radar Level Transmitter for Process Applications
Code	Frequency Band
U	US Market Only (10 GHz)
S	Switzerland Market Only (10 GHz)
A	All Other Markets (10 GHz)
Code	Product Certification
NA	None
E1	CENELEC/ATEX Flameproof
E5	FM Explosion-proof
E6	CSA Explosion-proof
E7	IECEX Flameproof
Code	Power Supply
P	24-240 V DC/AC 0-60 Hz
Code	Primary Output
5A	4-20 mA with HART communication, Passive Output
5B	4-20 mA with HART communication, Passive Output, Intrinsically Safe Circuit ⁽¹⁾
5C	4-20 mA with HART communication, Active Output
5D	4-20 mA with HART communication, Active Output, Intrinsically Safe Circuit ⁽¹⁾
7A	FOUNDATION Fieldbus
7B	FOUNDATION Fieldbus, Intrinsically Safe Circuit ⁽¹⁾
8A	RS 485 Protocol - Modbus
Code	Secondary Output ⁽²⁾⁽³⁾
0	None
1 ⁽⁴⁾	4-20 mA, Passive Output ⁽⁵⁾
2 ⁽⁴⁾	4-20 mA, Passive Output, Intrinsically Safe Circuit ⁽¹⁾
3	4-20 mA, Active Output ⁽⁵⁾
4	4-20 mA, Active Output, Intrinsically Safe Circuit ⁽¹⁾
Code	Display Unit
N	None
P	LOI, Factory mounted on transmitter
R	LOI, Remote mounted
T	LOI, Remote mounted with temp inputs (1-6 spot elements with common returns)
Code	Volume Calculation
E	Basic Volume Equations (Standard)
V	Strapping Table, up to 100 points
Typical Model Number: 5601 S E1 P 5A 0 P E Antenna Selection ⁽⁶⁾	

(1) Intrinsically safe circuit only applicable if product certificate codes E1, E5, E6, or E7 is selected.

(2) Secondary output codes are not available in a combination of E6 CSA and Primary Output codes 5A, 5B, 5C, or 5D.

(3) Secondary output codes 1, 2, 3, and 4 require an isolator when used in combination with 7A, 7B, or 8A.

(4) Not available in combination with Primary Output codes 5A, 5B, 5C, or 5D.

(5) Not allowed in combination with Display Unit codes P, R, or T.

(6) Select the antenna type and options using Table 9, Table 10, Table 11, Table 13, and Table 14.

TABLE 9. Rod Antenna

Code	Antenna Type	Antenna Size	Antenna Material	Note
Rod				
11S		1.5 in. threaded version	SST 316L and PTFE	Inactive Length 4 inch (100 mm)
12S		2 in. (DN50) nozzles	SST 316L and PTFE	Inactive Length 4 inch (100 mm)
13S		3 in. (DN80) nozzles	SST 316L and PTFE	Inactive Length 4 inch (100 mm)
14S		4 in. (DN100) nozzles	SST 316L and PTFE	Inactive Length 4 inch (100 mm)
11L		1.5 in. threaded version	SST 316L and PTFE	Inactive Length 10 inch (250 mm)
12L		2 in. (DN50) nozzles	SST 316L and PTFE	Inactive Length 10 inch (250 mm)
13L		3 in. (DN80) nozzles	SST 316L and PTFE	Inactive Length 10 inch (250 mm)
14L		4 in. (DN100) nozzles	SST 316L and PTFE	Inactive Length 10 inch (250 mm)
1XX		Customer specific rod or material		Consult Factory
Code Tank Seal				
N		Not Applicable		
Code O-ring Material				
V		Viton® Fluoroelastomer		
K		Kalrez® 6375		
E		EPDM		
B		Buna-N		
Code Process Connection				
NR		Antenna with Plate Design		
		<i>NOTE: Customer supplied flange or see Table 18 on page Level-25 for flange options</i>		
XX		Special Process Connection		Consult Factory
Threaded Version				
TN		Threaded 1.5 in. NPT		
TB		Threaded 1.5 in. G		
Code Options				
Q8		Material Traceability Certification per EN 10204 3.1.B		
Typical Model Number: Selected code from Table 8 on page Level-18 11S N F TN				

Rosemount 5600 Series

TABLE 10. Cone Antenna

Code	Antenna Type	Antenna Size	Antenna Material	Note
Cone				
23S		3 in. (DN80) nozzles	SST 316L	Pipe Installation Only
24S		4 in. (DN100) nozzles	SST 316L	Free propagation or 4" pipe
26S		6 in. (DN150) nozzles	SST 316L	Free propagation or 6" pipe
28S		8 in. (DN200) nozzles	SST 316L	Free propagation only
2AS		10 in. (DN250) nozzles	SST 316L	Free propagation only
23H		3 in. (DN80) nozzles	Hastelloy C22	Longer Lead-time, Consult Factory
24H		4 in. (DN100) nozzles	Hastelloy C22	Longer Lead-time, Consult Factory
26H		6 in. (DN150) nozzles	Hastelloy C22	Longer Lead-time, Consult Factory
28H		8 in. (DN200) nozzles	Hastelloy C22	Longer Lead-time, Consult Factory
23T		3 in. (DN80) nozzles	Titanium Gr 1/2	Longer Lead-time, Consult Factory
24T		4 in. (DN100) nozzles	Titanium Gr 1/2	Longer Lead-time, Consult Factory
26T		6 in. (DN150) nozzles	Titanium Gr 1/2	Longer Lead-time, Consult Factory
28T		8 in. (DN200) nozzles	Titanium Gr 1/2	Longer Lead-time, Consult Factory
23M		3 in. (DN80) nozzles	Monel 400	Longer Lead-time, Consult Factory
24M		4 in. (DN100) nozzles	Monel 400	Longer Lead-time, Consult Factory
26M		6 in. (DN150) nozzles	Monel 400	Longer Lead-time, Consult Factory
28M		8 in. (DN200) nozzles	Monel 400	Longer Lead-time, Consult Factory
23Z		3 in. (DN80) nozzles	Tantalum	Longer Lead-time, Consult Factory
24Z		4 in. (DN100) nozzles	Tantalum	Longer Lead-time, Consult Factory
26Z		6 in. (DN150) nozzles	Tantalum	Longer Lead-time, Consult Factory
28Z		8 in. (DN200) nozzles	Tantalum	Longer Lead-time, Consult Factory
2XX		Customer specific cone or material		Consult Factory
Code		Tank Seal		
P		PTFE		
Q		Quartz		
Code		O-ring Material		
V		Viton [®] Fluoroelastomer		
K		Kalrez [®] 6375		
E		EPDM		
B		Buna-N		
Code		Process Connection		
NR		Antenna with Plate Design <i>NOTE: Customer supplied flange or see Table 18 on page Level-25 for flange options</i>		
XX		Special Process Connection		Consult Factory
		Tri-clamp connection	Flange Material	Note
BT		3 in. Tri-Clamp Flange	SST 316L	Longer Lead-time, Consult Factory
CT		4 in. Tri-Clamp Flange	SST 316L	Longer Lead-time, Consult Factory
DT		6 in. Tri-Clamp Flange	SST 316L	Longer Lead-time, Consult Factory
ET		8 in. Tri-Clamp Flange	SST 316L	Longer Lead-time, Consult Factory
Code		Options		
Q8		Material Traceability Certification per EN 10204 3.1.B		
Typical Model Number: Selected code from Table 8 on page Level-18 24S P V NR				

TABLE 11. Process Seal Antenna

Code	Antenna Type	Antenna Size	Antenna Material	Note
Process Seal				
34S		4 in. (DN100) nozzles	PTFE	
36S		6 in. (DN150) nozzles	PTFE	
Tank Seal				
P		PTFE		
O-ring Material				
N		Not Applicable		
Process Connection				
NF		None, Customer to supply flange per dimensions on FIGURE 16.		
XX		Special Process Connection		Consult Factory
Stainless Steel Flange				
Flange Material				
CA		4 in. ANSI Class 150	SST 316L	
DA		6 in. ANSI Class 150	SST 316L	
JA		DN100 PN16	SST 316L	
KA		DN150 PN16	SST 316L	
Options				
Q8		Material Traceability Certification per EN 10204 3.1.B		
Typical Model Number: Selected code from Table 8 on page Level-18 34S P N JA				

TABLE 12. Parabolic Antenna

Code	Antenna Type	Antenna Size	Antenna Material	Note
Parabolic				
45S		ø18 in. (440mm)	SST	Clamped with Integrated Inclination, Low pressure version
46S		ø18 in. (440mm)	SST	Welded with Integrated Inclination, High pressure version
4XX		Customer Specific	Customer Specific	Consult Factory
Tank Seal				
P		PTFE		
O-ring Material				
V		Viton® Fluoroelastomer		
Process Connections				
NF		None, Flange Ready		
XX		Special Process Connection		Consult Factory
Options				
Q8		Material Traceability Certification per EN 10204 3.1.B		
PB		PTFE Protective Cover (PTFE Bag) Not suitable for hazardous applications.		
Typical Model Number: Selected code from Table 8 on page Level-18 45S P V NR				

TABLE 13. Extended Cone Antenna

Code	Antenna Type	Antenna Size	Antenna Material	Note
Extended				
73S		3 in. (DN80) nozzles	SST 316L	Standard length 20 inch (500 mm)
74S		4 in. (DN100) nozzles	SST 316L	Standard length 20 inch (500 mm)
76S		6 in. (DN150) nozzles	SST 316L	Standard length 20 inch (500 mm)
7XX		Customer specific extended cone or material		Consult Factory
Code		Tank Seal		
P		PTFE		
Q		Quartz		
Code		O-ring Material		
V		Viton® Fluoroelastomer		
K		Kalrez® 6375		
E		EPDM		
B		Buna-N		
Code		Process Connections		
NR		Antenna with Plate Design		
		<i>NOTE: Customer supplied flange or see Table 18 on page Level-25 for flange options</i>		
XX		Special Process Connection		Consult Factory
Code		Options		
Q8		Material Traceability Certification per EN 10204 3.1.B		
Typical Model Number: Selected code from Table 8 on page Level-18 76S P V NR				

TABLE 14. Cone Antenna with Integrated Flushing Connection

Code	Antenna Type	Antenna Size	Antenna Material	Note
Cone with Integrated Flushing Connection				
94S		4 in. (DN100) nozzles	SST 316L	Consult Factory
96S		6 in. (DN150) nozzles	SST 316L	Consult Factory
98S		8 in. (DN200) nozzles	SST 316L	Consult Factory
Code		Tank Seal		
P		PTFE		
Q		Quartz		
Code		O-ring Material		
V		Viton® Fluoroelastomer		
K		Kalrez® 6375		
E		EPDM		
B		Buna-N		
Code		Process Connection		
XX		Special Process Connection		Consult Factory
		Stainless Steel Flange Welded to Antenna		Note⁽¹⁾
CL		4 in. ANSI Class 150		Max 101 psig at 392 °F (7 bar at 200 °C)
DL		6 in. ANSI Class 150		Max 145 psig at 392 °F (10 bar at 200 °C)
FL		8 in. ANSI Class 150		Max 145 psig at 392 °F (10 bar at 200 °C)
JL		DN100 PN16		Max 72 psig at 392 °F (5 bar at 200 °C)
KL		DN150 PN16		Max 87 psig at 392 °F (6 bar at 200 °C)
LL		DN200 PN16		Max 87 psig at 392 °F (6 bar at 200 °C)
CH		4 IN. ANSI Class 150, SST, Higher Pressure		Max 145 psig at 752 °F (10 bar at 400 °C)
DH		6 IN. ANSI Class 150, SST, Higher Pressure		Max 145 psig at 752 °F (10 bar at 400 °C)
FH		8 IN. ANSI Class 150, SST, Higher Pressure		Max 145 psig at 752 °F (10 bar at 400 °C)
JH		DN100 PN 16, SST< Higher Pressure		Max 145 psig at 752 °F (10 bar at 400 °C)
KH		DN150 PN 16, SST< Higher Pressure		Max 145 psig at 752 °F (10 bar at 400 °C)
LH		DN200 PN 16, SST< Higher Pressure		Max 145 psig at 752 °F (10 bar at 400 °C)
Code		Options		
Q8		Material Traceability Certification per EN 10204 3.1.B		
Typical Model Number: Selected code from Table 8 on page Level-18 94S P K KL				

(1) Pressure and temperature rating may be lower depending on Tank Seal selection

TABLE 15. Transmitter Options (multiple selections allowed)

Code	Options
	Material Traceability Certification
Q8	Material Traceability Certification per EN 10204 3.1B
	Calibration Data Certification
Q4	Calibration Data Certificate
	Software Configuration
C1	Custom Software Configuration (CDS required with order)
	Alarm Limits
C4	NAMUR Alarm Level, High Alarm
C8	Low Alarm (Standard Rosemount Alarm)
	Conduit Adapters
G1	1/2 inch NPT Cable Gland Kit
G2	1/2 inch NPT/ M20 Adapters (Set of 3)
	Conduit Electrical Connector⁽¹⁾
GE	M12, 4-pin, Male Connector (eurofast®)
GM	A size Mini, 4-pin, Male Connector (minifast®)
	Protective Cover
PB ⁽²⁾	PTFE Protective Cover (PTFE Bag)
	Special Procedures
P1 ⁽³⁾	Hydrostatic Testing
U1 ⁽⁴⁾	TÜV Overfill Protection

(1) Not available with certain hazardous location certifications. Contact an Emerson Process Management Representative for details.

(2) For Parabolic Antenna only. Not suitable for hazardous applications.

(3) Not available in combination with Parabolic Antenna option codes.

(4) Requires Secondary Output Code 3 or 4 (Active Output).

TABLE 16. Typical Model Code Examples

5601 A E1 P 5A 0 P E 24S P V NR
ATEX approval, passive HART primary output and display mounted on transmitter. Basic Volume calculation. Antenna is a 4 inch Cone, SST with PTFE Seal and Viton® Fluoroelastomer O-rings. No options.
5601 U E5 P 7A 2 T V 94S P K CL C1
FM approval, FOUNDATION™ fieldbus output and remote mounted display with temp inputs and a secondary 4-20mA passive IS output. Volume table with up to 100 points. 4 inch Cone Antenna with integrated cleaning, PTFE seal and kalrez® o-rings for high temperature and pressure. Flange is ANSI 4 inch Class 150 stainless steel. Custom configuration selected.

Accessories

TABLE 17. Accessories Part Numbers

Part Number	Description	Note
Modems		
03300-7004-0001	HART Modem and cables	Viator by MACTek®
03300-7004-0002	HART USB Modem and cables	Viator by MACTek®
05600-5004-0001	K2 RS485 Modbus Modem	For Sensor Bus Port connection (requires PC with 9-pin Serial port)
Antenna Accessories		
05600-5001-0001	PTFE Protective Cover (PTFE Bag)	For Parabolic Antenna only. Not suitable for hazardous applications.

Rod and Cone Antenna Flanges

TABLE 18. Non-welded Flange Part Numbers

Stainless Steel Flanges			
Part Number	Flange Size	Dimensions	Material
05600-1811-0211	ANSI 2 inch Class 150	Acc. To ANSI B16.5	SST 316L ⁽¹⁾
05600-1811-0231	ANSI 2 inch Class 300	Acc. To ANSI B16.5	SST 316L ⁽¹⁾
05600-1811-0311	ANSI 3 inch Class 150	Acc. To ANSI B16.5	SST 316L
05600-1811-0331	ANSI 3 inch Class 300	Acc. To ANSI B16.5	SST 316L
05600-1811-0411	ANSI 4 inch Class 150	Acc. To ANSI B16.5	SST 316L
05600-1811-0431	ANSI 4 inch Class 300	Acc. To ANSI B16.5	SST 316L
05600-1811-0611	ANSI 6 inch Class 150	Acc. To ANSI B16.5	SST 316L
05600-1811-0811	ANSI 8 inch Class 150	Acc. To ANSI B16.5	SST 316L
05600-1810-0231	DN50 PN40	Acc. To EN 1092-1	EN 1.4404 ⁽²⁾
05600-1810-0311	DN80 PN16	Acc. To EN 1092-1	EN 1.4404 ⁽²⁾
05600-1810-0331	DN80 PN40	Acc. To EN 1092-1	EN 1.4404 ⁽²⁾
05600-1810-0411	DN100 PN16	Acc. To EN 1092-1	EN 1.4404 ⁽²⁾
05600-1810-0431	DN100 PN40	Acc. To EN 1092-1	EN 1.4404 ⁽²⁾
05600-1810-0611	DN150 PN16	Acc. To EN 1092-1	EN 1.4404 ⁽²⁾
05600-1810-0811	DN200 PN16	Acc. To EN 1092-1	EN 1.4404 ⁽²⁾

(1) Use gasket type Ia.

(2) Gasket type according to EN 1514-1 and bolting according to EN1515-2.

Application and Configuration Data Sheet

Always fill out the Application Section for ordering and pre-order support.

Fill out the Application Section AND the Configuration Section if the C1 option is ordered.

For a complete list of C1 parameters see last page.

Bold parameters are very important for evaluation of the application and configuration of the device. They should always be filled out.

APPLICATION SECTION

Always fill out this section.

Customer and Sales Person Information

Customer/ End User: _____ Customer Contact: _____

Field Sales Person: _____ Customer Phone/E-mail: _____

Final Destination: _____
(city), (state, province), (country)

Industry:

Chemical
Food and Beverage
Life Sciences
Metals and Mining
Oil and Gas

Power
Pulp and Paper
Refining
Water and Waste Water
Other _____

Process Information

Process Name: _____ Measurement Type: Liquid Level Solid Level
 Interface Level/Interface

Process Media: _____ Dielectric Constant⁽¹⁾: 1.4-1.9 4.0-10.0
 1.9-2.5 >10
 2.5-4.0 Unknown

Process Temperature:

Minimum: _____ degrees F
 degrees C

Maximum: _____ degrees F
 degrees C

Process Pressure:

Minimum: _____ psig
 bar

Maximum: _____ psig
 bar

Process Information (Continued)

Is Vapor Present: None Light Medium Heavy

Turbulence Type: Calm Surface Gently Stirred Turbulent Conditions

Turbulence due to:

- Chemical Reaction
- Bubbling/boiling
- Agitation
- Air lance
- Splashing during fill

Foam Present: Not Applicable Occasionally Constantly

Foam Type: Not Applicable Light (Airy) Medium Heavy (Dense)

Foam Thickness: _____ Inches Millimeters

Rapid Level Changes⁽²⁾ No >1.6-in./s (40 mm/s) > 3.9-in./s (100 mm/s)

Product Build-up Potential: None Film Heavy

Viscosity Most Similar To: Water Machine Oil Olive Oil Honey Syrup/Molasses Tar

at Temperature: _____ degrees F degrees C

(1) If Interface Measurement, enter DC of lower product. DC of upper product entered on Page 2.

(2) Due to overall level changes, not to turbulent surface.

Rosemount 5600 Series

Process Information (Continued)

For Interface Products Only⁽¹⁾

Upper Product: _____

Maximum Upper Product Thickness: _____ mm m ft in

Upper Product Dielectric Constant: _____

Fully Submerged Probe⁽²⁾ No Yes

(1) Not available with the Rosemount 5400 and 5600.

(2) If the probe is fully submerged at all times, the Rosemount 3301 can be used for measuring the interface between the upper and the lower product.

For Solid Products Only⁽¹⁾

Dust: None Constantly Occasionally

Particle Size Most Similar To: Wood chips Fine dust (flour, cement) Grains (rice, corn)
 Small stone/gravel Small rocks/chunks (limestone)

Fill Cycle Surface Profile: Relatively Flat Moderate incline Steep Incline

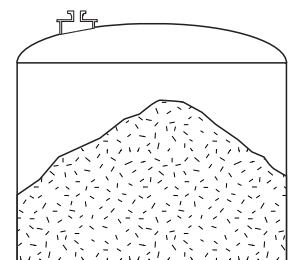
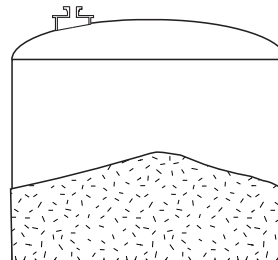
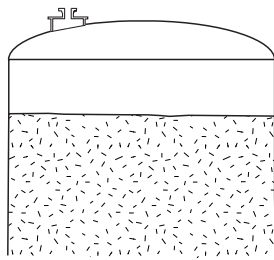

Material Density: _____ lbs/ft³
 kg/l

(1) Available with the Rosemount 3300 and 5600 only.

Tank Geometry (Required for C1 option)

Tank Shape: Unknown Vertical cylinder
 Spherical Horizontal Cylinder
 Cubical Other (describe: _____)

Tank Material of Construction: Metal Glass lined
 Non-metal Other: _____

Tank Bottom: Unknown
 Flat
 Dome/Dish/Bullet
 Cone
 Other (Inclined or obstructed due to heating coils, pipes, etc.).

Reference Height (R): _____ mm m ft in

Tank Diameter (D): _____ mm m ft in

Tank Nozzle Distance to Wall (d): _____ mm m ft in

Agitator⁽¹⁾: No Yes

Baffles⁽¹⁾: No Yes

Heating Coils⁽¹⁾: No Around inside of tank wall
 Across Tank bottom

Other Internal Obstacles⁽¹⁾: No Yes

Upper Null Zone⁽²⁾: _____ mm cm m ft in

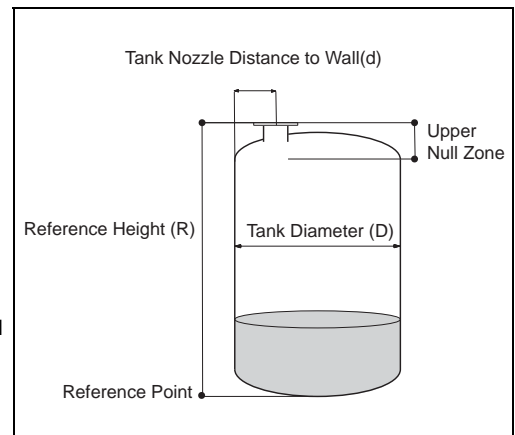

(1) If the answer to this question is 'Yes', please provide a drawing.

(2) The transmitter will not consider echoes in this area. Normally set to suppress nozzle echoes. Preset for 5400 and 5600 based on antenna selection.

Fitting Dimensions

Nozzle

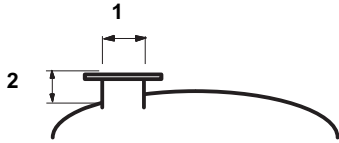

Stilling Well

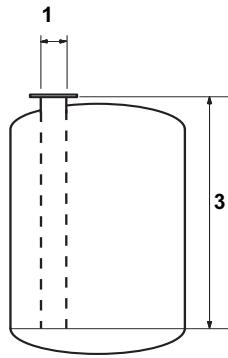

Bypass Pipe

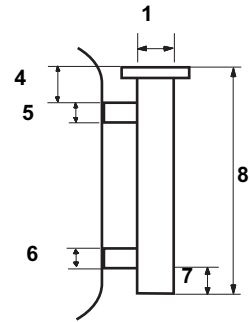

1. Flange / Thread

- 1-in. NPT / G
- 1.5-in. NPT / G
- 2-in. / DN 50
- 3-in. / DN 80
- 4-in. / DN 100

- 6-in. / DN 150
- 8-in. / DN 200
- Fisher 249B (for Rosemount 3300, bypass pipe)
- Fisher 249C (for Rosemount 3300, bypass pipe)
- Masoneilan (for Rosemount 3300, bypass pipe)

Pressure Class

- 150 lb.
- 300 lb.
- 600 lb.

- PN 16
- PN 40
- PN 64

Other _____

Dimensions

Nozzle 2. _____ in. ft mm cm m

Stilling Well 3. _____ in. ft mm cm m

Bypass Pipe 4. _____ in. ft mm cm m

- 5. _____
- 6. _____
- 7. _____
- 8. _____

Mounting Nozzle has a valve
Is an isolation window desired?

- Yes No
- Yes No

Additional Application Information

Preferred Device Type: Contacting Non-Contacting

Additional Comments: _____

LCD Meter Configuration - Only if M1 is ordered⁽¹⁾

Variables: Level Distance Volume⁽²⁾ Interface Level⁽³⁾
 Interface Distance⁽³⁾ % of Range Upper Product Thickness⁽³⁾ Signal Strength⁽⁴⁾

Variable units according to previous table. Carousel Toggling is used to present more than one variable.

- (1) Pre-configuration of display is not available with Rosemount 5600.
- (2) For meaningful volume units, the remainder of this CDS needs to be filled out.
- (3) Not available with the Rosemount 5400 and 5600.
- (4) Not available with the Rosemount 3300.

Volume Calculation (If applicable)

Volume is calculated based on ideal shapes or by a strapping table.

If volume calculation based on strapping table is needed, please provide an additional file with volume table to be imported or fill in the next page.

The maximum strapping table points are 10 for the 3300, 20 for the 5400, and 100 for the 5600.

If your transmitter is an ideal shape, please select what ideal shape to use. Add the dimensions for the selected shape.

Vertical Cylinder

Dimensions (*include units*):

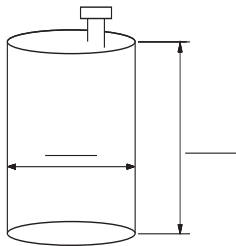

Horizontal Cylinder

Dimensions (*include units*):

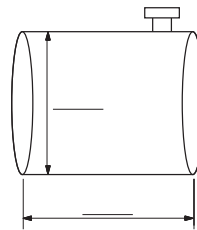

Sphere

Dimensions (*include units*):

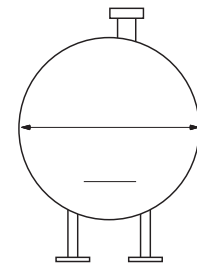

Vertical Cylinder with Bullet Ends⁽¹⁾

Dimensions (*include units*):

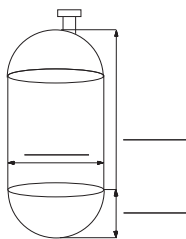

Horizontal Cylinder with Bullet Ends⁽¹⁾

Dimensions (*include units*):

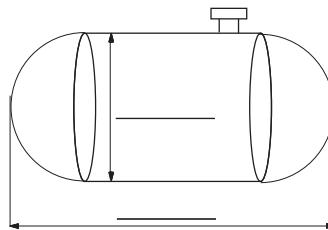

(1) Available for the Rosemount 3300 and 5400 only.

Rosemount 5600 Strapping Table

Pre-configuration of strapping table available only for Rosemount 5600. Strapping table is available for the Rosemount 3300 and 5400 also, but is not included in C1 basic configuration for these transmitters. (Up to 10 points for the Rosemount 3300, 20 for the Rosemount 5400, and 100 points for the 5600 can be used. Data may be submitted to the factory using a data spreadsheet program).

Strap Point Number	Level	Volume
1 (Bottom of Tank)		
2		
3		
4		
5		
6		
7		
8		
9		
10		
11		
12		
13		
14		
15		
16		
17		
18		
19		
20		

C1 parameters

3300: Hardware Tag, Software Tag, Dielectric Constant/s, Primary Variable Assignment, Secondary Variable Assignment, Variable Units Level, Variable Units Volume, LRV, URV, RGH, Upper Null Zone, LCD Configuration, Volume Configuration (Ideal Tank Shapes)

5400: Hardware Tag, Software Tag, Dielectric Constant, Turbulence Type, Foam Type, Rapid Level Changes, Variable Unit Level, Variable Unit Volume, Primary Variable Assignment, LRV, URV, Tank Shape, Tank Bottom, RGH, LCD Configuration, Fitting Type, Pipe Diameter, Volume Configuration (Ideal Tank Shapes)

5600: Hardware Tag, Software Tag, Dielectric Constant, Rapid Level Changes, Solid Product, Foam, Turbulence, Tank Shape, Tank Bottom, RGH, Primary Variable Assignment, LRV, URV, Secondary Variable Assignment (if ordered), Secondary LRV, Secondary URV, Volume Configuration (Ideal Tank Shapes or Strapping Table)

Rosemount 5600 Series

Product Data Sheet
00813-0100-4024, Rev FA
March 2008

*Rosemount and the Rosemount logotype are registered trademarks of Rosemount Inc.
PlantWeb is a registered trademark of one of the Emerson Process Management group of companies.
HART is a registered trademark of the HART Communication Foundation.
Viton, and Kalrez are registered trademarks of Du Pont Performance Elastomers.
FOUNDATION is a trademark of the Fieldbus Foundation.
DeltaV is a trademark of Emerson Process Management group of companies.
Hastelloy is a registered trademark of Haynes International.
Monel is a registered trademark of International Nickel Co.
Eurofast and Minifast are registered trademarks of Turck Inc.
All other marks are the property of their respective owners.
Standard Terms and Conditions of Sale can be found at www.rosemount.com/terms_of_sale*

Emerson Process Management

Rosemount Inc.

8200 Market Boulevard
Chanhassen, MN 55317 USA
T (U.S.) 1-800-999-9307
T (International) (952) 906-8888
F (952) 949-7001

www.rosemount.com



Emerson Process Management

Heath Place
Bognor Regis
West Sussex PO22 9SH
England
Tel 44 (1243) 863 121
Fax 44 (1243) 867 554

Emerson Process Management Asia Pacific Private Limited

1 Pandan Crescent
Singapore 128461
T (65) 6777 8211
F (65) 6777 0947/65 6777 0743
Enquiries@AP.emersonprocess.com



EMERSON
Process Management