

User's Guide

EXTECH[®]
INSTRUMENTS

A FLIR COMPANY

Model 382260

80W 3-in-1 Switching DC Power Supply

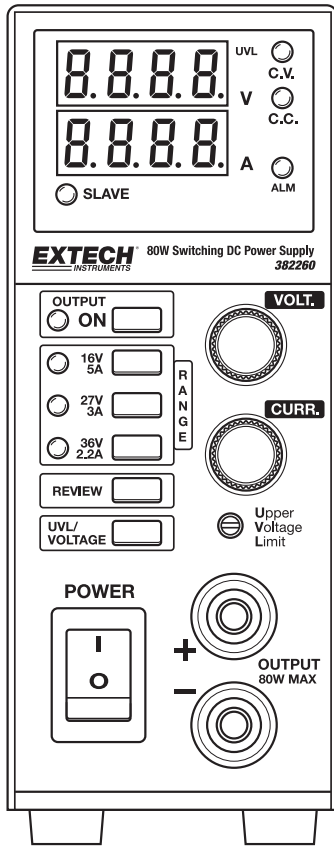

Introduction

Congratulations on your purchase of the Extech 80W 3-in-1 Switching DC Power Supply. The Model 382260 has three output ranges that perform like 3 power supplies in one. It can be used for many applications including bench testing, field service, hobby and telecommunication equipment use. This power supply is shipped fully tested and calibrated and, with proper use, will provide years of reliable service.

Safety

This manual contains important safety and operation instructions for correct use of the power supply. Read through the manual and pay special attention to the markings and labels of this unit and equipment to be connected.

Pay special attention to these two types of notices used in this manual

WARNING : Failure to observe this warning may cause injury to persons and damage to power supply or connected equipment.

CAUTION : Failure to observe this warning may result in damage to equipment and improper functioning of the power supply.

WARNING :

1. Do not use this power supply near water.
2. Do not operate or touch this power supply with wet hands.
3. Do not open the casing of the power supply when it is connected to ac mains.
4. Refer all servicing to qualified service personnel only.
5. Before replacing the AC fuse find out and clear up the cause first.
6. Replace the AC fuse with the same type and rating as the original fuse.

CAUTION :

1. Use a grounded 3 pin AC source .
2. This unit is for indoor use only .
3. Do not operate or place this unit in a humid, dusty, in direct sunlight location or near any heat source.
4. Before plugging into local AC mains, check with the rating label at the back of the unit.
5. Do not block any ventilation openings of the unit.
6. This unit must be used within the specified rating, regular excessive continuous loading may cause damage to the power supply.
7. The gauge size of input power cable must be at least 0.75mmsq and the total length of power cable must not exceed 3m.
8. Input Fuse Recommended: T3AL250V (3A Time-Lag)

Power Supply Description

1. Power On/Off switch
2. Output terminals
3. UVL adjustment screw
4. Current adjustment
5. Voltage adjustment
6. Upper Voltage Limit button
7. Preview button
8. Range selector
9. Output On/Off button
10. UVL indicator
11. Constant Voltage indicator
12. Constant Current indicator
13. Overvoltage or Temperature alarm
14. Slave indicator
15. LED Voltage Display
16. LED Current Display
17. Master/Slave switch
18. Master/Slave control terminals
19. Remote Sensing terminals
20. Rear Output terminals
21. AC power socket

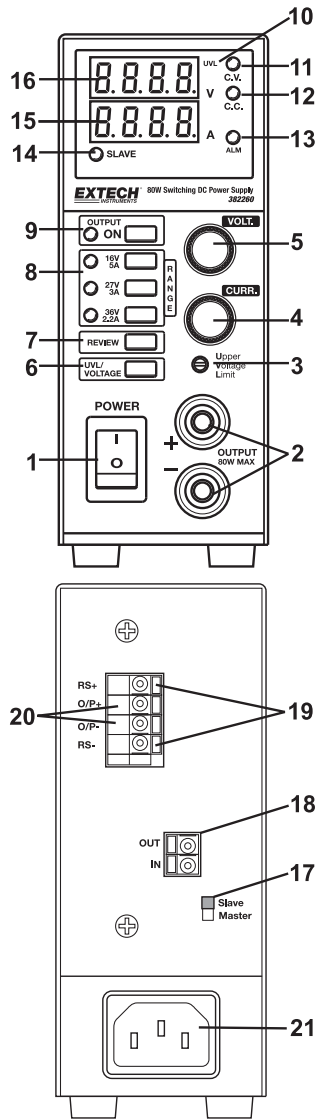

Stand Alone Operation

1. Set the Master/Slave switch located on the back of the unit to the Master position.
2. Without any load attached, use the POWER button to switch on the power supply and the LED indicator will light. There should not be any reading on the voltmeter and ammeter.
3. Press the Output On/Off button and its green LED will light up, the voltmeter will display the previously set output voltage. Use the voltage control knob to adjust the voltage to the desired level.
4. Use the Output On/Off button to turn off the output. **Note:** The output will automatically shut off when one of the other voltage/current range selection buttons is pushed. This is to prevent damage to a connected load if the voltage/current values are set too high.
5. Press and Hold the Preview button to display the previously set voltage and current limiting values. With this button held down, you can set the current limiting value without connecting to a load or shorting the output terminals. **Note:** The Output button must be in the Off position.

Setting the Upper Voltage Limit (UVL) Value

The Upper Voltage Limit Value is an added protection for voltage sensitive loads. When the output voltage exceeds the set UVL, the output terminal will automatically shut off and the ALM LED will light. **Note:** Only one UVL value can be set for all three ranges.

1. Press the UVL/Voltage and insert a small screwdriver into the UVL adjustment screw.
2. Turn clockwise to increase the voltage limit and counter-clockwise to decrease the UVL value.

Remote Sensing Operation

When the output current is high or the load connection is long, there is a voltage drop across the connecting cable. This results in a difference between the voltage at the output terminal and load point. By making an extra connection using the Remote Sensing Terminal to the load point, the reading at the output terminal and load point is the same.

Caution: Observe correct polarity and never short the Remote Sensing terminal

1. Connect the load to the power supply.
2. Connect the load to the Remote Sensing Terminal.

Note: Always disconnect the Remote Sensing terminal connections first.

Master/Slave Operation

Two or more Model 382260 Power Supplies can be connected in parallel to increase output current to the sum of the connected supplies. In this mode of operation, the Master power supply will control all of the voltage and current settings of the Slave units.

1. Set all of the power supplies to the same upper voltage limit (UVL) and voltage/current range.
2. Set the voltage and current limit of all of the slaves to maximum values.
3. Switch off all of the power supplies.
4. Set the Master/Slave switch to the Slave position on all of the Slave units.
5. Connect the power supplies together using the Master/Slave control circuit on the back of the power supplies. **Note:** For proper performance all connecting cables and output cables should be the same gauge and length.
6. Using either the output terminals on the front or back of the units, connect the output cables in parallel to the load.
7. Switch on the Master unit first and set to the desired voltage.
8. Switch on the slave units and the Slave Indicator LED will light to confirm correct connection.
9. All output voltages and currents are now controlled by the Master unit.

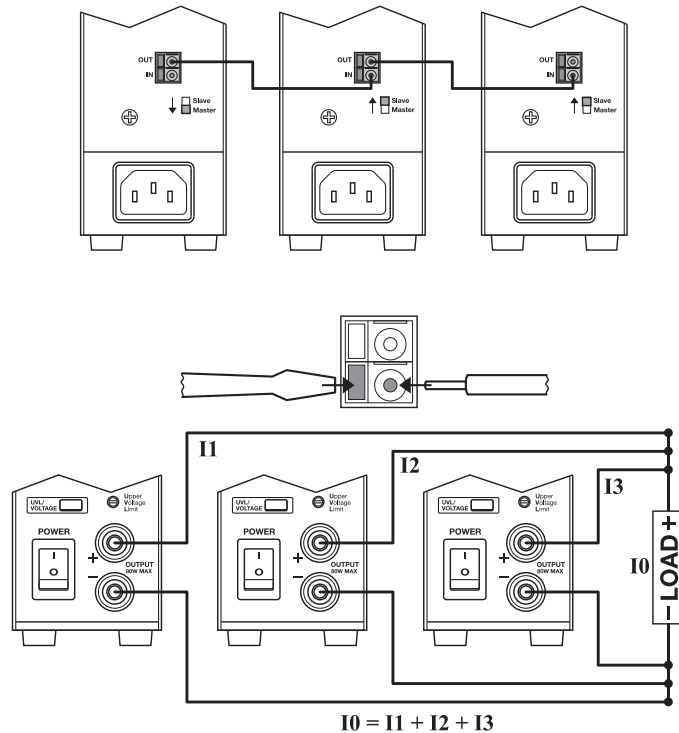

Specifications

Display	Dual 4-digit LED
Display Accuracy	±(1% + 5 counts)
Voltage Output, DC	0 to 16.4V 0 to 27.6V 0 to 36.8
Current Output, DC	0 to 5.1A 0 to 3.1A 0 to 2.3A
Ripple and Noise	<30mVp-p
Line Regulation	< 4mV/<10mA
Load Regulation	< 20mV/<10mA
Efficiency	>75%
Power Factor	>0.9
Operating %RH	10 to 80% RH
Altitude	2000m
Installation Category	CAT 2
Pollution degree	2
Power	90 to 264VAC (47 to 63Hz)
Supply voltage fluctuation	± 10% of stated operating voltage
Dimensions	13 x 5 x 2" (330 x 127 x 53.5mm) (WxHxD)
Weight	4.2lbs. (1.9 kg)

Warranty

EXTECH INSTRUMENTS CORPORATION warrants this instrument to be free of defects in parts and workmanship for **one year** from date of shipment (a six month limited warranty applies to sensors and cables). If it should become necessary to return the instrument for service during or beyond the warranty period, contact the Customer Service Department at (781) 890-7440 ext. 210 for authorization or visit our website www.extech.com for contact information. A Return Authorization (RA) number must be issued before any product is returned to Extech. The sender is responsible for shipping charges, freight, insurance and proper packaging to prevent damage in transit. This warranty does not apply to defects resulting from action of the user such as misuse, improper wiring, operation outside of specification, improper maintenance or repair, or unauthorized modification. Extech specifically disclaims any implied warranties or merchantability or fitness for a specific purpose and will not be liable for any direct, indirect, incidental or consequential damages. Extech's total liability is limited to repair or replacement of the product. The warranty set forth above is inclusive and no other warranty, whether written or oral, is expressed or implied.

Trouble Shooting

PROBLEM	INDICATIONS	POSSIBLE CAUSES	SUGGESTED SOLUTIONS
Power supply not working	Panel display, LED Indicators not on	A. AC power input not connected B. AC input fuse blown	A. Check AC power connection, B. Contact factory
No DC output power	Voltage meter zero indication. ALM (13) Alarm led on CC (12) led on	A. Output on off button not on . B. UVL (10) protection triggered C. OTP protection triggered D. Output short circuit	A. Check output LED (9) is on or not, push (9) to on. B. Check UVL set voltage by pushing (6), re-set UVL to applicable limit. C. Check vent holes at top and bottom is clear, ambient temperature too high D. Check and undo short circuit of output connection.
Voltage meter reading grossly inaccurate	Actual output voltage is grossly different from the meter read out	A. Volt meter shows not the output voltage. B. Possible misalignment in voltmeter calibration	A. Check the LED indicator of UVL on the top right hand side of the Volt meter, if it lights up then the volt meter only shows the set UVL value. Push (6) to go back to output voltage. B. Contact factory
Ampere meter reading grossly inaccurate	In CV mode , the actual current measured is grossly different from the Amp meter reading	Possible misalignment in calibration .	Contact factory
The activated (auto- cross over) current limiting value is different from the preset cc value	All indicators and display are normal , only CC mode has the problem	For stand alone unit, Master & Slave Switch (17) in wrong position (Slave). Wrong setting or connection in Master & Slave or set up procedure.	Check the Master & Slave switch (17) correct position. Use stand alone mode to check power supply separately without any connection to slave units. Follow the procedure carefully and make sure there is only one Master unit.

Calibration and Repair Services

Extech offers repair and calibration services for the products we sell. Extech also provides NIST certification for most products. Call the Customer Service Department for information on calibration services available for this product. Extech recommends that annual calibrations be performed to verify meter performance and accuracy.



Support line (781) 890-7440

Technical Support: Extension 200; E-mail: support@extech.com

Repair & Returns: Extension 210; E-mail: repair@extech.com

Product specifications subject to change without notice

For the latest version of this User's Guide, Software updates, and other up-to-the-minute product information, visit our website: www.extech.com

Extech Instruments Corporation, 285 Bear Hill Rd., Waltham, MA 02451

Copyright © 2007 Extech Instruments Corporation (a FLIR company)

All rights reserved including the right of reproduction in whole or in part in any form.