

Rosemount Integral Orifice Flowmeter Series

**HIGHLY ACCURATE SMALL-BORE FLOW
MEASUREMENT CAPABILITY WITH
MINIMAL INSTALLATION AND
MAINTENANCE REQUIREMENTS**

- Improves accuracy and repeatability in 1/2-in., 1-in., and 1 1/2-in. line sizes
- Reduces leak points by over 50% and minimizes line plugging
- Improves reliability with consistent installations
- Multivariable measurement for gas and steam

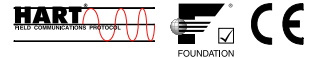

Contents

Rosemount Integral Orifice Flowmeter Series	page 2
1195 Integral Orifice Series Selection Guide	page 3
Rosemount 3051SFP Proplate Flowmeter	page 4
Specifications	page 4
Product Certifications	page 10
Dimensional Drawings	page 14
Ordering Information	page 15
Rosemount 3095MFP Mass Proplate Flowmeter	page 20
Specifications	page 20
Product Certifications	page 24
Dimensional Drawings	page 26
Ordering Information	page 27
Rosemount 1195 Integral Orifice Primary Element	page 30
Specifications	page 30
Dimensional Drawings	page 33
Ordering Information	page 34
HART Configuration Data Sheet (CDS)	page 39
FOUNDATION fieldbus™ Configuration Data Sheet (CDS)	page 42
Fluid Data Sheet (FDS)	page 45

Rosemount Integral Orifice Flowmeter Series

Industry leading integrated DP flowmeters

By integrating Rosemount pressure transmitters with the 1195 Integral Orifice Series primary element, Rosemount provides the highest performing DP Flowmeters. This fully integrated flowmeter eliminates the need for fittings, tubing, valves, adapters, and mounting brackets, thereby reducing welding and installation time.

Improves accuracy and repeatability in 1/2-in., 1-in., and 1 1/2-in. line sizes

Using an integral orifice flowmeter solution will eliminate the three measurement inaccuracies recorded in small orifice line installations.

1. The Rosemount 1195 Integral Orifice honed body reduces ID uncertainty
2. By inserting precision bored upstream and downstream sections of pipe, the velocity profile distortion due to pipe roughness is reduced
3. The self-centering design of the 1195 Integral Orifice Plate eliminates plate misalignment

Using integral orifice flowmeter solutions will greatly improve measurement accuracy and repeatability.

Improves reliability and maintenance costs

The integral orifice flowmeter solutions eliminate impulse lines, reducing leak points by over 50% and decrease start-up time due to the flexibility of numerous process connection options. The direct mount design minimizes line plugging by eliminating long lines, small-bore ports, and crevices while providing consistently reliable installations.

MultiVariable measurement for gas and steam

Measuring mass flow (base volumetric) in Gas and Steam reduces process variability. The Embedded Flow Software re-calculates ALL flow coefficients and calculates density and mass flow in Real Time. Coupled with DP technology, the Integral Orifice Flowmeter solution is designed to maximize performance in real-world conditions.

Rosemount DP-Flow Solutions

Annubar® Flowmeter Series: Rosemount 3051SFA ProBar®, 3095MFA Mass ProBar®, 485, and 285

The state-of-the-art, fifth generation Rosemount 485 *Annubar* combined with the 3051S or 3095 MultiVariable transmitter creates an accurate, repeatable and dependable insertion-type flowmeter. The Rosemount 285 provides a commercial product offering for your general purpose applications.

Compact Orifice Flowmeter Series: Rosemount 3051SFC, 3095MFC, and 405

Compact Orifice Flowmeters can be installed between existing flanges, up to a Class 600 (PN100) rating. In tight fit applications, a conditioning orifice plate version is available, requiring only two diameters of straight run upstream.

Rosemount pressure transmitters combined with the Rosemount 1195 Integral Orifice create Best-in-Class Flowmeters

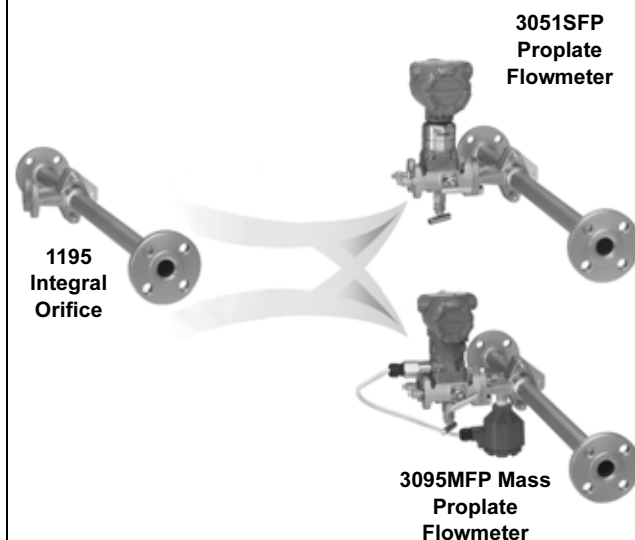

Advanced *PlantWeb*® functionality



Rosemount orifice flowmeters power *PlantWeb* through a scalable architecture, advanced diagnostics, and MultiVariable capabilities. This reduces operational and maintenance expenditures while improving throughput and utilities management.

Integral Orifice Flowmeter Series: Rosemount 3051SFP ProPlate®, 3095MFP Mass ProPlate, and 1195

These integral orifice flowmeters eliminate the inaccuracies that become more pronounced in small orifice line installations. The completely assembled, ready to install flowmeters reduce cost and simplify installation.

Orifice Plate Primary Element Systems: Rosemount 1495 and 1595 Orifice Plates, 1496 Flange Unions and 1497 Meter Sections

A comprehensive offering of orifice plates, flange unions and meter sections that is easy to specify and order. The 1595 Conditioning Orifice provides superior performance in tight fit applications.

1195 Integral Orifice Series Selection Guide

Rosemount 3051SFP Proplate Flowmeter

See ordering information on page 15.

- Combines the Rosemount 3051S scalable pressure transmitter with the 1195 Integral Orifice Primary
- Wireless output now available, delivering information rich data with > 99% reliability
- Accuracy up to $\pm 0.95\%$ of volumetric flow rate
- Remote display and interface assembly enables direct mounting with “at-grade” operator interface
- *FOUNDATION*[®] fieldbus protocol available
- Ideal fluid type: liquid



3051SFP ProPlate Flowmeter

Rosemount 3095MFP Mass Proplate Flowmeter

See ordering information on page 27.

- Combines the Rosemount 3095MV MultiVariable mass flow transmitter with the 1195 Integral Orifice
- Accuracy up to $\pm 0.90\%$ of mass flow rate in gas and steam
- Measures differential pressure, static pressure, and process temperature all in one flowmeter assembly
- Dynamically calculates compensated mass flow
- Ideal fluid types: gas and steam



3095MFP Mass ProPlate Flowmeter

Rosemount 1195 Integral Orifice Primary

See ordering information on page 34.

- Integral manifold head allows direct mounting of DP transmitters
- Ideal fluid types: liquid, gas, and steam
- Accuracy up to $\pm 0.75\%$ of discharge coefficient uncertainty
- Direct mounting capability

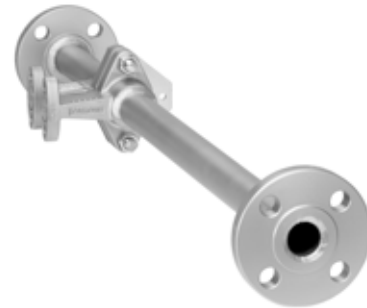

1195 Integral Orifice Primary

Rosemount 3051SFP Proplate Flowmeter

SPECIFICATIONS

Performance

System Reference Accuracy

Percentage (%) of volumetric flow rate⁽¹⁾

Beta (β) ⁽²⁾	Classic (8:1 flow turndown)	Ultra (8:1 flow turndown)	Ultra for Flow (10:1 flow turndown)
$\beta < 0.1$	±2.70%	±2.65%	±2.60%
$0.1 < \beta < 0.2$	±1.60%	±1.45%	1.40%
$0.2 < \beta < 0.6$	±1.20%	±1.10%	±0.95%
$0.6 < \beta < 0.8$	±1.80%	±1.70%	±1.65%

(1) Without associated straight run piping, discharge coefficient uncertainty can add up to 1.5% - 5% additional error. Consult the factory for additional information.

(2) $\beta = \frac{\text{Orifice Plate Bore}}{\text{body I.D.}}$

Repeatability

±0.1%

Line Sizes

- 1/2-in. (15 mm)
- 1-in. (25 mm)
- 1 1/2-in. (40 mm)

Performance Statement Assumptions

- Use associated piping.
- Electronics are trimmed for optimum flow accuracy

Sizing

Contact a Emerson Process Management sales representative for assistance. A "Configuration Data Sheet" is required prior to order for application verification.

Functional

Service

- Liquid
- Gas
- Steam

4–20 mA/HART

Zero and Span Adjustment

Zero and span values can be set anywhere within the range. Span must be greater than or equal to the minimum span.

Output

Two-wire 4–20 mA is user-selectable for linear or square root output. Digital process variable superimposed on 4–20 mA signal, available to any host that conforms to the HART protocol.

Power Supply

External power supply required.

Standard transmitter (4–20 mA): 10.5 to 42.4 V dc with no load
3051S HART Diagnostics transmitter: 12 to 42 Vdc with no load

Load Limitations

Maximum loop resistance is determined by the voltage level of the external power supply, as described by:

Standard Transmitter

Maximum Loop Resistance = $43.5 * (\text{Power Supply Voltage} - 10.5)$

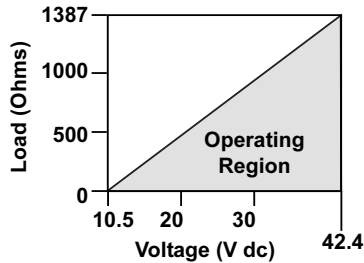

The HART communicator requires a minimum loop resistance of 250Ω for communication.

ASP™ Diagnostics Suite for HART (Option Code DA1)

The 3051S provides Abnormal Situation Prevention indication for a breakthrough in diagnostic capability. The New 3051S ASP™ Diagnostics Suite for HART includes Statistical Process Monitoring (SPM), variable logging with time stamp and advanced process alerts. The enhanced EDDL graphic display provides an intuitive and user-friendly interface to better visualize these diagnostics.

The integral SPM technology calculates the mean and standard deviation of the process variable 22 times per second and makes them available to the user. The 3051S uses these values and highly flexible configuration options for customization to detect many user-defined or application specific abnormal situations (e.g. detecting plugged impulse lines and fluid composition change). Variable logging with time stamp and advanced process alerts capture valuable process and sensor data to enable quick troubleshooting of application and installation issues.

FOUNDATION fieldbus

Power Supply

External power supply required; transmitters operate on 9.0 to 32.0 V dc transmitter terminal voltage.

Current Draw

17.5 mA for all configurations (including LCD display option)

FOUNDATION fieldbus Parameters

Schedule Entries	14 (max.)
Links	30 (max.)
Virtual Communications Relationships (VCR)	20 (max.)

Standard Function Blocks

Resource Block

- Contains hardware, electronics, and diagnostic information.

Transducer Block

- Contains actual sensor measurement data including the sensor diagnostics and the ability to trim the pressure sensor or recall factory defaults.

LCD Block

- Configures the local display.

2 Analog Input Blocks

- Processes the measurements for input into other function blocks. The output value is in engineering or custom units and contains a status indicating measurement quality.

PID Block with Auto-tune

- Contains all logic to perform PID control in the field including cascade and feedforward. Auto-tune capability allows for superior tuning for optimized control performance.

Backup Link Active Scheduler (LAS)

The transmitter can function as a Link Active Scheduler if the current link master device fails or is removed from the segment.

Software Upgrade in the Field

Software for the 3051S with FOUNDATION fieldbus is easy to upgrade in the field using the FOUNDATION fieldbus Common Device Software Download procedure.

PlantWeb Alerts

Enable the full power of the PlantWeb digital architecture by diagnosing instrumentation issues, communicating advisory, maintenance, and failure details, and recommending a solution.

Advanced Control Function Block Suite (Option Code A01)

Input Selector Block

- Selects between inputs and generates an output using specific selection strategies such as minimum, maximum, midpoint, average, or first "good."

Arithmetic Block

- Provides pre-defined application-based equations including flow with partial density compensation, electronic remote seals, hydrostatic tank gauging, ratio control and others.

Signal Characterizer Block

- Characterizes or approximates any function that defines an input/output relationship by configuring up to twenty X, Y coordinates. The block interpolates an output value for a given input value using the curve defined by the configured coordinates.

Integrator Block

- Compares the integrated or accumulated value from one or two variables to pre-trip and trip limits and generates discrete output signals when the limits are reached. This block is useful for calculating total flow, total mass, or volume over time.

Output Splitter Block

- Splits the output of one PID or other control block so that the PID will control two valves or other actuators.

Control Selector Block

- Selects one of up to three inputs (highest, middle, or lowest) that are normally connected to the outputs of PID or other control function blocks.

Rosemount Integral Orifice Flowmeter Series

Product Data Sheet
00813-0100-4686, Rev NA
March 2008

Block	Execution Time
Resource	-
Transducer	-
LCD Block	-
Analog Input 1, 2	20 milliseconds
PID with Auto-tune	25 milliseconds
Input Selector	20 milliseconds
Arithmetic	20 milliseconds
Signal Characterizer	20 milliseconds
Integrator	20 milliseconds
Output Splitter	20 milliseconds
Control Selector	20 milliseconds

Fully Compensated Mass Flow Block (Option Code H01)

Calculates fully compensated mass flow based on differential pressure with external process pressure and temperature measurements over the fieldbus segment. Configuration for the mass flow calculation is easily accomplished using the Rosemount Engineering Assistant.

ASP™ Diagnostics Suite for FOUNDATION fieldbus (Option Code D01)

The 3051S ASP™ Diagnostics Suite for FOUNDATION fieldbus provides Abnormal Situation Prevention indication and enhanced EDDL graphic displays for easy visual analysis.

The integral Statistical Process Monitoring (SPM) technology calculates the mean and standard deviation of the process variable 22 times per second and makes them available to the user. The 3051S uses these values and highly flexible configuration options for customization to detect many user-defined or application specific abnormal situations (e.g. detecting plugged impulse lines and fluid composition change).

Wireless Self-Organizing Networks (3051S only)

Output

Wireless enabled HART.

Transmit Rate

User selectable, 15 sec. to 60 min.

Power Module

Replaceable, Intrinsically Safe Lithium-thionyl chloride Power Module with polybutadine terephthalate (PBT) enclosure.

Five-year life at one minute transmit rate: ten-year life at ten minute transmit rate.⁽¹⁾

(1) Reference conditions are 70 °F (21 °C), and routing data for three additional network devices.

NOTE

Continuous exposure to ambient temperature limits, -40 °F (-40 °C) or 185 °F (85 °C), may reduce specified life by less than 20 percent.

Process Temperature Limits

Direct Mount Transmitter

- -40 to 450 °F (40 to 232 °C)

Remote Mount Transmitter

- -148 to 850 °F (-100 to 454 °C)⁽¹⁾

(1) High temperature option G must be selected.

Transmitter Temperature Limits

Ambient

- -40 to 185 °F (-40 to 85 °C)
- With Integral Mount LCD Display⁽¹⁾: -40 to 175 °F (-40 to 80 °C)

Storage

- -50 to 230 °F (-46 to 110 °C)
- With Integral Mount LCD Display: -40 to 185 °F (-40 to 85 °C)
- With wireless output (code X): -40 to 185 °F (-40 to 85 °C)

(1) LCD display may not be readable and LCD updates will be slower at temperatures below -4 °F (-20 °C).

Maximum Working Pressure

Transmitter

- Range 1A: Zero to two times the absolute pressure range with a maximum of 2000 psia (138 bar).
- Range 2A/3A: Zero to two times the absolute pressure range with a maximum of 3626 psia (250 bar).

Flowmeter

- Pressure retention per ANSI B16.5 600 lb. or DIN PN100

TABLE 1. 1195 Pressure Limits

Line Size	Process Connection Code	Maximum Working Pressure @ 100 °F ⁽¹⁾⁽²⁾
1/2-in. (12.7 mm)	S1 or P2 T1 or P1	3000 psig (207 bar) 1500 psig (103 bar)
1-in. (25.4 mm)	S1 or P2 T1 or P1	2000 psig (138 bar) 1500 psig (103 bar)
1 1/2-in. (38.1 mm)	S1 or P2 T1 or P1	1500 psig (103 bar) 1500 psig (103 bar)
All	Flanged	Meets flange primary pressure rating per ANSI B16.5 (EN-1092-1 for DIN flanges)

(1) For pressure ratings at temperatures less than -20 °F (-29 °C) or above 100 °F (38 °C) consult an Emerson Process Management representative.

(2) Transmitter static pressure range may limit maximum working pressure. Refer to Static Pressure Ranges specification.

Humidity Limits

- 0-100% relative humidity

Turn-On Time

Performance within specifications less than 2 seconds (typical) after power is applied to the transmitter

Damping

Analog output response to a step input change is user-selectable from 0 to 60 seconds for one time constant. This software damping is in addition to sensor module response time

Failure Mode Alarm

HART 4-20mA (output option codes A and B)

If self-diagnostics detect a gross transmitter failure, the analog signal will be driven offscale to alert the user. Rosemount standard (default), NAMUR, and custom alarm levels are available (see Table 2).

High or low alarm signal is software-selectable or hardware-selectable via the optional switch (option D1).

TABLE 2. Alarm Configuration

	High Alarm	Low Alarm
Default	≥ 21.75 mA	≤ 3.75 mA
NAMUR compliant ⁽¹⁾	≥ 22.5 mA	≤ 3.6 mA
Custom levels ⁽²⁾	20.2 - 23.0 mA	3.6 - 3.8 mA

(1) Analog output levels are compliant with NAMUR recommendation NE 43, see option codes C4 or C5.

(2) Low alarm must be 0.1 mA less than low saturation and high alarm must be 0.1 mA greater than high saturation.

3051S Safety-Certified Transmitter Failure Values

Safety accuracy: 2.0%⁽¹⁾

Safety response time: 1.5 seconds

(1) A 2% variation of the transmitter mA output is allowed before a safety trip. Trip values in the DCS or safety logic solver should be derated by 2%.

Dynamic Performance

	4 - 20 mA (HART®) ⁽¹⁾	Fieldbus protocol ⁽²⁾	Typical Transmitter Response Time
Total Response Time (Td + Tc)⁽³⁾:			
3051S_C, Ranges 2A - 3A:	100 milliseconds	152 milliseconds	
Range 1A:	255 milliseconds	307 milliseconds	
Dead Time (Td)⁽⁴⁾	45 milliseconds (nominal)	97 milliseconds	
Update Rate	3051S 22 times per second	22 times per second	

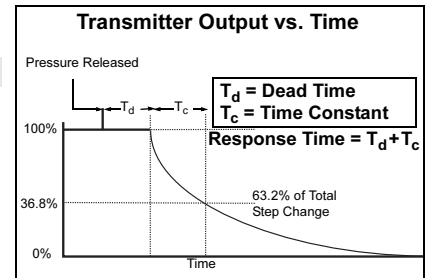

(1) Dead time and update rate apply to all models and ranges; analog output only

(2) Transmitter fieldbus output only, segment macro-cycle not included.

(3) Nominal total response time at 75 °F (24 °C) reference conditions. For option code DA1, add 45 milliseconds (nominal) to 4-20 mA (HART®) total response time values.

(4) For option code DA1, dead time (Td) is 90 milliseconds (nominal).

Installation Considerations

Pipe Orientation

Orientation/ Flow Direction	Process ⁽¹⁾		
	Gas	Liquid	Steam
Horizontal	D/R	D/R	D/R
Vertical Up	R	R	R
Vertical Down	R	NR	NR

(1) *D* = Direct mount acceptable (recommended)
R = Remote mount acceptable
NR = Not recommended

Flowmeter Orientation

Gas (Horizontal)

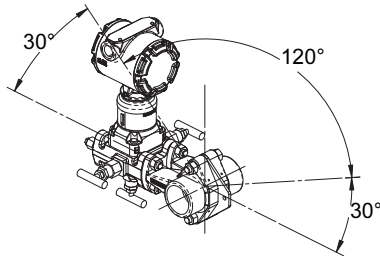

Liquid and Steam (Horizontal)

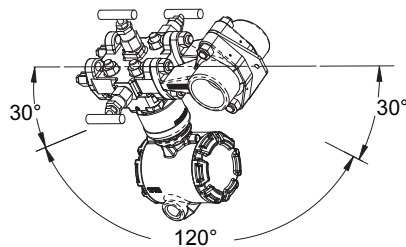

Gas (Vertical)

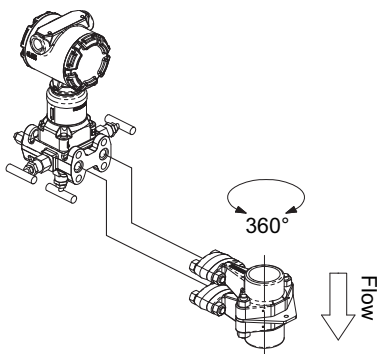

Liquid (Vertical)

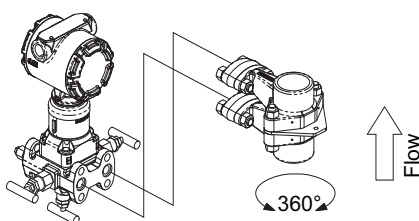

Physical

Temperature Measurement

RTD in Downstream Section

- 100 Ohm platinum with 1/2-in. NPT nipple and union (078 series with Rosemount 644 housing)
- Standard RTD cable is shielded armored cable, length is 12 feet (3.66 m)

Thermowell with Remote RTD with 1/2-in. SST weld couplet

Electrical Considerations

1/2-14 NPT, G^{1/2}, and CM20 conduit. HART interface connections permanently fixed to terminal block

Material of Construction

Orifice Plate

- 316/316L SST
- *Hastelloy* C-276
- *Monel* 400

Body

- 316 SST (CF8M), material per ASTM A351
- *Hastelloy* C-276 (CW12MW), material per ASTM A494

Pipe Material (If Applicable)

- A312 Gr 316/316L, B622 UNS N10276, *Hastelloy* C-276

Flange

- A182 Gr 316/316L, SB-564 UNS N10276, *Hastelloy* C-276
- Flange pressure limits are per ANSI B16.5
- Flange face finish per ANSI B16.5, 125 to 250 RMS

Body Bolts/Studs

- ASTM A193 Gr B8M studs
- ASTM A193 Gr B8M Class 2 body studs provided for high temperature option code G

Transmitter Connection Studs

- ASTM A193 Gr B8M studs

Gaskets/O-rings

- Glass filled PTFE
- *Inconel*® X-750 provided for high temperature option code G
- Gaskets and o-rings must be replaced each time the 3051SFP is disassembled for installation or maintenance.

Orifice Type

Square edged—orifice bore size

- 0.066-in and larger

Quadrant edged—orifice bore size (for 1/2-in. line size only)

- 0.034-in
- 0.020-in
- 0.014-in
- 0.010-in

NOTE

Integral orifice bodies contain corner tapped pressure ports.

Pipe Lengths

- Upstream and downstream associated piping sections are available on the 3051SFP. The table below lists the standard overall length (lay length) as a function of end connections and line size.

Flanged Process Connection ⁽¹⁾ (2) (3)	Line Size		
	1/2-in. (15 mm)	1-in. (25 mm)	1 1/2-in. (40 mm)
RF, ANSI Class 150, slip-on	18.2 (463)	28.9 (734)	40.3 (1023)
RF, ANSI Class 300, slip-on	18.2 (463)	28.9 (734)	40.3 (1023)
RF, ANSI Class 600, slip-on	18.2 (463)	28.9 (734)	40.3 (1023)
RF, DIN PN16, slip-on	18.2 (463)	28.9 (734)	40.3 (1023)
RF, DIN PN40, slip-on	18.2 (463)	28.9 (734)	40.3 (1023)
RF, DIN PN100, slip-on	18.2 (463)	28.9 (734)	40.3 (1023)
RF, ANSI Class 150, weld-neck	21.8 (554)	33.2 (843)	44.9 (1140)
RF, ANSI Class 300, weld-neck	22.2 (564)	33.7 (856)	45.5 (1156)
RF, ANSI Class 600, weld-neck	22.8 (579)	34.3 (871)	46.1 (1171)
RTJ, ANSI Class 150, slip-on	18.2 (463)	28.9 (734)	40.3 (1023)
RTJ, ANSI Class 300, slip-on	18.2 (463)	28.9 (734)	40.3 (1023)
RTJ, ANSI Class 600, slip-on	18.2 (463)	28.9 (734)	40.3 (1023)
NPT / Beveled Process Connection⁽¹⁾⁽²⁾⁽³⁾	18 (457)	28.9 (734)	40.3 (1023)

(1) See the ordering information for model code description.

(2) Consult factory for other lengths.

(3) See page 37 for additional information on associated pipe lengths.

Weight

The following weights are approximate

Line Size	With Body		With Flanged Piping ⁽¹⁾	
	lb	kg	lb	kg
1/2-in. (15 mm)	13.6	6.2	17.6	8.0
1-in. (25 mm)	15.6	7.1	21.6	9.8
1 1/2-in. (40 mm)	17.6	8.0	34.6	15.7

(1) As supplied with standard lengths, ANSI Class 150 flanges.

Process-Wetted Parts

Integral Manifolds

- 316 SST
- Hastelloy C-276

Remote Manifolds

- 316 SST
- Hastelloy C-276

Transmitter Vent Valves and Process Flanges

- 316 SST
- Hastelloy C-276

Process Isolating Diaphragms

- 316L SST
- Hastelloy C-276

O-rings

- Glass-filled PTFE / Inconel X-750

Integral Manifold O-Rings

- PTFE / Graphite (D7)

Non-Wetted Parts

Sensor Module Fill Fluid

- Silicone oil
- Inert Fill optional

Cover O-rings

- Buna-N

Remote Mounting Brackets

- SST

Sensor mounting (including nuts, bolts, and gasket)

- SST (CS optional for high temperature)

Electronic Housing

- Low-copper aluminum or CF-3M (Cast version of 316L SST) NEMA 4X, IP 66, IP 68 (not available with wireless output (code X))

Paint

- Polyurethane

Bolts

- SST

Antenna

- PBT/polycarbonate (PC) integrated omnidirectional antenna

PRODUCT CERTIFICATIONS

Approved Manufacturing Locations

Rosemount Inc. — Chanhassen, Minnesota USA
Emerson Process Management GmbH & Co. — Wessling, Germany
Emerson Process Management Asia Pacific Private Limited — Singapore
Beijing Rosemount Far East Instrument Co., LTD — Beijing, China

Ordinary Location Certification for FM

As standard, the transmitter has been examined and tested to determine that the design meets basic electrical, mechanical, and fire protection requirements by FM, a nationally recognized testing laboratory (NRTL) as accredited by the Federal Occupational Safety and Health Administration (OSHA).

European Directive Information

The EC declaration of conformity for all applicable European directives for this product can be found at www.rosemount.com. A hard copy may be obtained by contacting an Emerson Process Management representative.

ATEX Directive (94/9/EC)

Emerson Process Management complies with the ATEX Directive.

European Pressure Equipment Directive (PED) (97/23/EC)

Models 3051S_CA4; 3051S_CD2, 3, 4, 5; (also with P9 option)
Pressure Transmitters — QS Certificate of Assessment -
EC No. PED-H-100, Module H Conformity Assessment

All other Model 3051S Pressure Transmitters
— Sound Engineering Practice

Transmitter Attachments: Diaphragm Seal - Process Flange -
Manifold — Sound Engineering Practice

Primary Elements, Flowmeter
— See appropriate Primary Element QIG

Electro Magnetic Compatibility (EMC) (2004/108/EC)

All Models: EN 50081-1: 1992; EN 50082-2:1995;
EN 61326-1:1997 + A1, A2, and A3 – Industrial

Radio and Telecommunications Terminal Equipment Directive (R&TTE)(1999/5/EC)

Emerson Process Management complies with the R&TTE Directive.

HART & FOUNDATION Fieldbus Hazardous Locations Certifications

North American Certifications

FM Approvals

E5 Explosion-proof for Class I, Division 1, Groups B, C, and D; Dust Ignition-proof for Class II and Class III, Division 1, Groups E, F, and G; hazardous locations; enclosure Type 4X, conduit seal not required when installed according to Rosemount drawing 03151-1003.

15/IE Intrinsically Safe for use in Class I, Division 1, Groups A, B, C, and D; Class II, Division 1, Groups E, F, and G; Class III, Division 1; Class I, Zone 0 AEx ia IIC when connected in accordance with Rosemount drawing 03151-1006; Non-Incendive for Class I, Division 2, Groups A, B, C, and D Enclosure Type 4X
For entity parameters see control drawing 03151-1006.

Canadian Standards Association (CSA)

E6 Explosion-proof for Class I, Division 1, Groups B, C, and D; Dust Ignition-proof for Class II and Class III, Division 1, Groups E, F, and G; suitable for Class I, Division 2, Groups A, B, C, and D, when installed per Rosemount drawing 03151-1013, CSA Enclosure Type 4X; conduit seal not required.

16/IF Intrinsically Safe for Class I, Division 1, Groups A, B, C, and D when connected in accordance with Rosemount drawings 03151-1016;
For entity parameters see control drawing 03151-1016.

European Certifications

11/IA ATEX Intrinsic Safety



Certificate No.: BAS01ATEX1303X  II 1G
EEx ia IIC T4 (T_a = -60 °C to 70 °C) -HART/Remote
Display/Quick Connect/HART Diagnostics
EEx ia IIC T4 (T_a = -60 °C to 70 °C) -FOUNDATION fieldbus
EEx ia IIC T4 (T_a = -60 °C to 40 °C) -FISCO
IP66
CE 1180

TABLE 3. Input Parameters

Loop / Power	Groups
U _i = 30 V	HART / FOUNDATION fieldbus/ Remote Display / Quick Connect / HART Diagnostics
U _i = 17.5 V	FISCO
I _i = 300 mA	HART / FOUNDATION fieldbus/ Remote Display / Quick Connect / HART Diagnostics
I _i = 380 mA	FISCO
P _i = 1.0 W	HART / Remote Display / Quick Connect / HART Diagnostics
P _i = 1.3 W	FOUNDATION fieldbus
P _i = 5.32 W	FISCO
C _i = 30 nF	SuperModule Platform / Quick Connect
C _i = 11.4 nF	HART / HART Diagnostics
C _i = 0	FOUNDATION fieldbus / Remote Display / FISCO
L _i = 0	HART / FOUNDATION fieldbus/ FISCO / Quick Connect / HART Diagnostics
L _i = 60 µH	Remote Display

Special conditions for safe use (x)

- The apparatus, excluding the Types 3051 S-T and 3051 S-C (In-line and Coplanar SuperModule Platforms respectively), is not capable of withstanding the 500V test as defined in Clause 6.4.12 of EN 50020. This must be considered during installation.
- The terminal pins of the Types 3051 S-T and 3051 S-C must be protected to IP20 minimum.

N1 ATEX Type n
Certificate No.: BAS01ATEX3304X  II 3 G
EEx nL IIC T4 ($T_a = -40\text{ °C TO } 70\text{ °C}$)
 $U_i = 45\text{ Vdc max}$
IP66
CE

Special conditions for safe use (x)

The apparatus is not capable of withstanding the 500V insulation test required by Clause 9.1 of EN 50021: 1999. This must be taken into account when installing the apparatus.

ND ATEX Dust
Certificate No.: BAS01ATEX1374X  II 1 D
 $T_{105\text{ °C}} (-20\text{ °C} \leq T_{\text{amb}} \leq 85\text{ °C})$
 $V_{\text{max}} = 42.4\text{ volts max}$
 $A = 22\text{ mA}$
IP66
CE 1180

Special conditions for safe use (x)

1. The user must ensure that the maximum rated voltage and current (42.4 volts, 22 milliampere, DC) are not exceeded. All connections to other apparatus or associated apparatus shall have control over this voltage and current equivalent to a category "ib" circuit according to EN 50020.
2. Cable entries must be used which maintain the ingress protection of the enclosure to at least IP66.
3. Unused cable entries must be filled with suitable blanking plugs which maintain the ingress protection of the enclosure to at least IP66.
4. Cable entries and blanking plugs must be suitable for the ambient range of the apparatus and capable of withstanding a 7J impact test.
5. The 3051S must be securely screwed in place to maintain the ingress protection of the enclosure. (The 3051S SuperModule must be properly assembled to the 3051S housing to maintain ingress protection.)

E1 ATEX Flameproof
Certificate No.: KEMA00ATEX2143X  II 1/2 G
EEx d IIC T6 ($-50\text{ °C} \leq T_{\text{amb}} \leq 65\text{ °C}$)
EEx d IIC T5 ($-50\text{ °C} \leq T_{\text{amb}} \leq 80\text{ °C}$)
 $V_{\text{max}} = 42.4\text{V}$
CE 1180

Special conditions for safe use (x)

This device contains a thin wall diaphragm. Installation, maintenance and use shall take into account the environmental conditions to which the diaphragm will be subjected. The manufacturer's instructions for installation and maintenance shall be followed in detail to assure safety during its expected lifetime. The Model 3051S pressure transmitter must include a Series 300S housing integrally mounted to a Series Model 3051S Sensor module as per Rosemount drawing 03151-1023.

Japanese Certifications

E4 TIIS Flameproof
Ex d IIC T6

Certificate	Description
TC15682	Coplanar with Junction Box Housing
TC15683	Coplanar with PlantWeb Housing
TC15684	Coplanar with PlantWeb Housing and LCD Display
TC15685	In-Line SST with Junction Box Housing
TC15686	In-Line <i>Hastelloy</i> with Junction Box Housing
TC15687	In-Line SST with PlantWeb Housing
TC15688	In-Line <i>Hastelloy</i> with PlantWeb Housing
TC15689	In-Line SST with PlantWeb Housing and LCD Display
TC15690	In-Line <i>Hastelloy</i> with PlantWeb Housing and LCD Display
TC17102	Remote Display

Australian Certifications

E7 SAA Flameproof and Dust Ignition-proof
Certification No.: AUS Ex 3798X
Ex d IIC T6 ($T_a = 60\text{ °C}$) IP66
DIP A21 TA T6 ($T_a = 60\text{ °C}$) IP66

Special conditions for safe use (x)

1. It is a condition of safe use that each housing shall be connected to external circuits via suitable conduit or Standards Australia certified cable glands. Where only one entry is used for connection to external circuits, the unused entry shall be closed by means of the blanking plug supplied by the equipment manufacturer or by a suitable Standards Australia certified blanking plug.
2. It is a condition of safe use that a dielectric strength test shall be applied whenever the terminal block is changed or replaced in either the dual compartment or single compartment housings. The breakdown current shall be less than 5 mA, when 500 V, 47 to 62 Hz, is applied for one minute. Note: if tested with an optional T1 transient protector terminal block fitted, the protection will operate and hence there will be no current indicated.
3. It is a condition of safe use that each transmitter module shall be used with a Model 300S housing, in order to comply with flameproof requirements.
4. It is a condition of safe use that each model 300S housing fitted with a transmitter module shall be marked with the same certification marking code information. Should the housing be replaced after initial supply to another model 300S housing, the replacement housing shall have the same certification marking code information as the housing it replaces.

IECEX Certifications

I7/IG IECEX Intrinsic Safety

Certificate No.: IECEXBAS04.0017X

Ex ia IIC T4 ($T_a = -60\text{ °C}$ to 70 °C) -HART/Remote

Display/Quick Connect/HART Diagnostics

Ex ia IIC T4 ($T_a = -60\text{ °C}$ to 70 °C) -FOUNDATION fieldbus

Ex ia IIC T4 ($T_a = -60\text{ °C}$ to 40 °C) -FISCO

IP66

TABLE 4. Input Parameters

Loop / Power	Groups
$U_i = 30\text{ V}$	HART / FOUNDATION fieldbus/ Remote Display / Quick Connect / HART Diagnostics
$U_i = 17.5\text{ V}$	FISCO
$I_i = 300\text{ mA}$	HART / FOUNDATION fieldbus/ Remote Display / Quick Connect / HART Diagnostics
$I_i = 380\text{ mA}$	FISCO
$P_i = 1.0\text{ W}$	HART / Remote Display / Quick Connect / HART Diagnostics
$P_i = 1.3\text{ W}$	FOUNDATION fieldbus
$P_i = 5.32\text{ W}$	FISCO
$C_i = 30\text{ nF}$	SuperModule Platform / Quick Connect
$C_i = 11.4\text{ nF}$	HART / HART Diagnostics
$C_i = 0$	FOUNDATION fieldbus / Remote Display / FISCO / Quick Connect / HART Diagnostics
$L_i = 0$	HART / FOUNDATION fieldbus / FISCO / Quick Connect / HART Diagnostics
$L_i = 60\text{ }\mu\text{H}$	Remote Display

Special conditions for safe use (x)

1. The Models 3051S HART 4-20mA, 3051S fieldbus, 3051S Profibus and 3051S FISCO are not capable of withstanding the 500V test as defined in clause 6.4.12 of IEC 60079-11. This must be taken into account during installation.
2. The terminal pins of the Types 3051S-T and 3051S-C must be protected to IP20 minimum.

N7 IECEX Type n

Certificate No.: IECEXBAS04.0018X

Ex nC IIC T4 ($T_a = -40\text{ °C}$ to 70 °C)

$U_i = 45\text{ Vdc MAX}$

IP66

Special conditions for safe use (x)

The apparatus is not capable of withstanding the 500 V insulation test required by Clause 8 of IEC 79-15: 1987.

Combinations of Certifications

Stainless steel certification tag is provided when optional approval is specified. Once a device labeled with multiple approval types is installed, it should not be reinstalled using any other approval types. Permanently mark the approval label to distinguish it from unused approval types.

- K1** Combination of E1, I1, N1, and ND
- K5** Combination of E5 and I5
- K6** Combination of E6 and I6
- K7** Combination of E7, I7, and N7
- KA** Combination of E1, I1, E6, and I6
- KB** Combination of E5, I5, I6 and E6
- KC** Combination of E5, E1, I5 and I1
- KD** Combination of E5, I5, E6, I6, E1, and I1

WIRELESS CERTIFICATIONS

Telecommunication Compliance

All wireless devices require certification to ensure that they adhere to regulations regarding the use of the RF spectrum. Nearly every country requires this type of product certification. Emerson is working with governmental agencies around the world to supply fully compliant products and remove the risk of violating country directives or laws governing wireless device usage. =

FCC and IC Approvals

This device complies with Part 15 of the FCC Rules. Operation is subject to the following conditions: This device may not cause harmful interference this device must accept any interference received, including interference that may cause undesired operation.

This device must be installed to ensure a minimum antenna separation distance of 20cm from all persons.

Ordinary Location Certification for FM

As standard, the transmitter has been examined and tested to determine that the design meets basic electrical, mechanical, and fire protection requirements by FM, a nationally recognized testing laboratory (NRTL) as accredited by the Federal Occupational Safety and Health Administration (OSHA).

European Directive Information

The EC declaration of conformity for all applicable European directives for this product can be found at www.rosemount.com. A hard copy may be obtained by contacting an Emerson Process Management representative.

ATEX Directive (94/9/EC)

Emerson Process Management complies with the ATEX Directive.

European Pressure Equipment Directive (PED) (97/23/EC)

Models 3051S_CA4; 3051S_CD2, 3, 4, 5; (also with P9 option)

Pressure Transmitters — QS Certificate of Assessment - EC No. PED-H-100, Module H Conformity Assessment

All other Model 3051S Pressure Transmitters — Sound Engineering Practice

Transmitter Attachments: Diaphragm Seal - Process Flange - Manifold — Sound Engineering Practice

Primary Elements, Flowmeter — See appropriate Primary Element QIG

Electro Magnetic Compatibility (EMC) (2004/108/EC)

All Models: EN 50081-1: 1992; EN 50082-2:1995; EN 61326-1:1997 + A1, A2, and A3 – Industrial

Radio and Telecommunications Terminal Equipment Directive (R&TTE)(1999/5/EC)

Emerson Process Management complies with the R&TTE Directive.

Hazardous Locations Certifications

North American Certifications

Factory Mutual (FM) Approvals

- I5** FM Intrinsically Safe, Non-Incendive, and Dust Ignition-proof. Intrinsically Safe for Class I/II/III, Division 1, Groups A, B, C, D, E, F, and G.
Zone Marking: Class I, Zone 0, AEx ia IIC
Temperature Codes T4 ($T_{amb} = -50$ to $70^{\circ}C$)
Non-Incendive for Class I, Division 2, Groups A, B, C, and D.
Dust Ignition-proof for Class II/III, Division 1, Groups E, F, and G.
Ambient temperature limits: -50 to $85^{\circ}C$
For use with Rosemount SmartPower options 00753-9220-XXXX only.
Enclosure Type 4X / IP66

CSA - Canadian Standards Association

- I6** CSA Intrinsically Safe
Intrinsically Safe for Class I, Division 1, Groups A, B, C, and D.
Temp Code T3C
Enclosure Type 4X / IP66
For use with Rosemount SmartPower options 00753-9220-XXXX only.

European Certifications

- I1** ATEX Intrinsic Safety
Certificate No.: BAS01ATEX1303X  II 1G
Ex ia IIC T4 ($T_a = -60^{\circ}C$ to $70^{\circ}C$)
IP66
For use with Rosemount SmartPower options 00753-9220-XXXX only.
CE 1180



Country	Restriction
Bulgaria	General authorization required for outdoor use and public service
France	Outdoor use limited to 10mW e.i.r.p.
Italy	If used outside of own premises, general authorization is required.
Norway	May be restricted in the geographical area within a radius of 20 km from the center of Ny-Alesund.
Romania	Use on a secondary basis. Individual license required.

Radio Power Label (See Figure 1) indicates output power configuration of the radio. Devices with this label are configured for output power less than 10 mW e.i.r.p. At time of purchase the customer must specify ultimate country of installation and operation.

Figure 1.

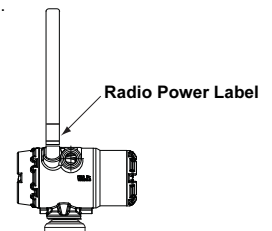

IECEX Certifications

- I7** IECEX Intrinsic Safety
Certificate No.: IECEX BAS 04.0017X
Ex ia IIC T4 ($T_a = -60^{\circ}C$ to $70^{\circ}C$)
For use with Rosemount SmartPower options 00753-9220-XXXX only.
IP66

Rosemount Integral Orifice Flowmeter Series

Product Data Sheet
00813-0100-4686, Rev NA
March 2008

DIMENSIONAL DRAWINGS

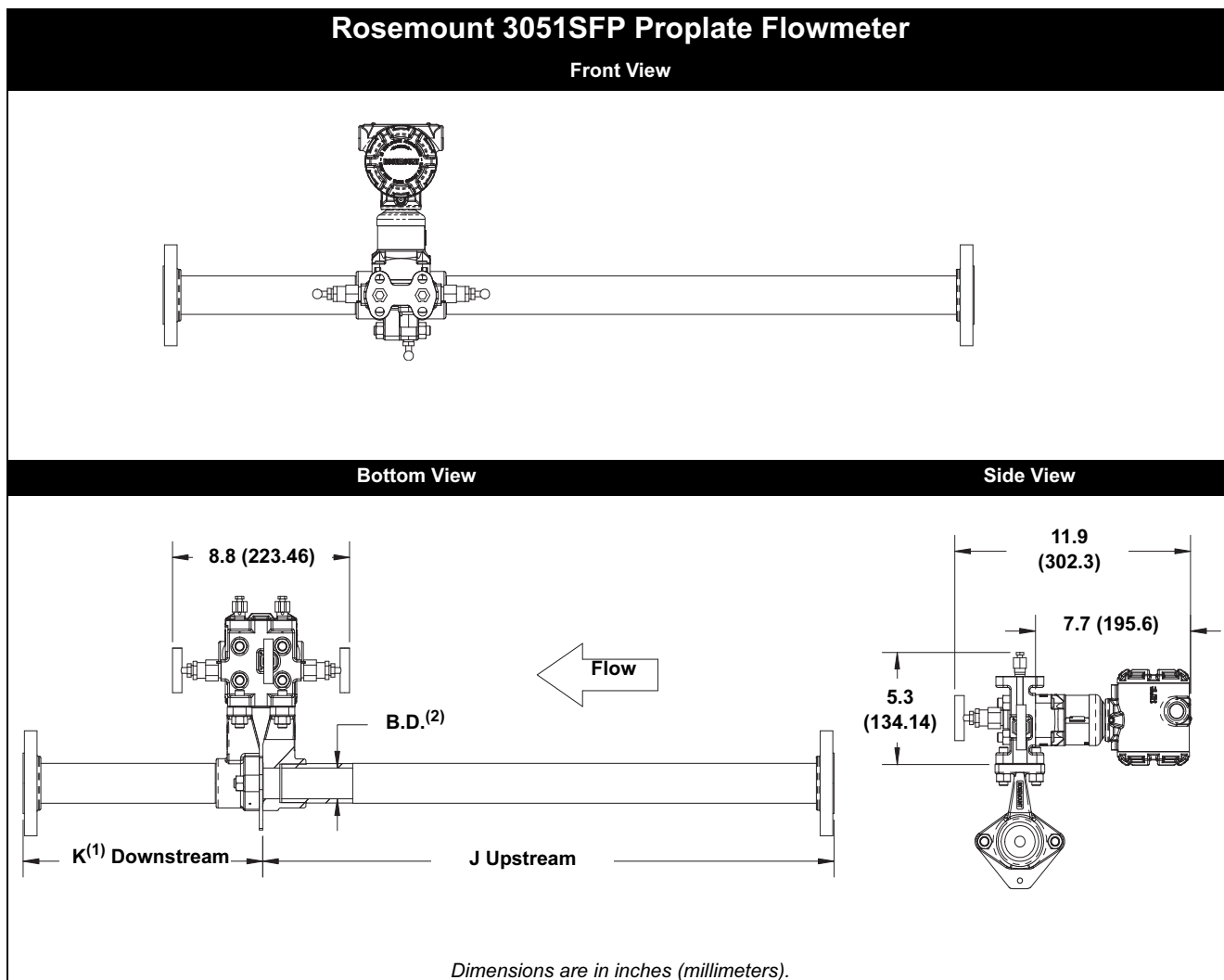

Dimension	Line Size					
	1/2-in. (12.7 mm)		1-in. (25.4 mm)		1 1/2-in. (38.1 mm)	
J (RF slip-on, RTJ slip-on, RF-DIN slip-on)	12.5-in.	318 mm	20.2-in.	513 mm	28.4-in.	721 mm
J (RF 150#, weld-neck)	14.3-in.	363 mm	22.3-in.	566 mm	30.7-in.	780 mm
J (RF 300#, weld-neck)	14.5-in.	368 mm	22.6-in.	574 mm	31.0-in.	787 mm
J (RF 600#, weld-neck)	14.8-in.	376 mm	22.9-in.	582 mm	31.3-in.	795 mm
K ((RF slip-on, RTJ slip-on, RF-DIN slip-on) ⁽¹⁾	5.7-in.	145 mm	8.7-in.	221 mm	11.9-in.	302 mm
K (RF 150#, weld-neck)	7.5-in.	191 mm	10.9-in.	277 mm	14.2-in.	361 mm
K (RF 300#, weld-neck)	7.7-in.	196 mm	11.1-in.	282 mm	14.5-in.	368 mm
K (RF 600#, weld-neck)	8.0-in.	203 mm	11.4-in.	290 mm	14.8-in.	376 mm
B.D. ⁽²⁾	0.664-in.	16.86 mm	1.097-in.	27.86 mm	1.567-in.	39.80 mm

(1) Downstream length shown here includes plate thickness of 0.162-in. (4.11 mm).

(2) B.D. is diameter of the precision bored portion of the upstream and downstream piping.

Rosemount 3051SFP Proplate Flowmeter Ordering Information

Model	Product Description
3051SFP	Proplate Flowmeter
Code	Measurement Type
D	Differential Pressure
Code	Body Material
S	316 SST
H	<i>Hastelloy C-276</i>
Code	Line Size
005	1/2-in. (15 mm)
010	1-in. (25 mm)
015	1 1/2-in. (40 mm)
Code	Process Connection
T1	NPT Female Body (not available with remote thermowell and RTD)
S1 ⁽¹⁾	Socket Weld Body (not available with remote thermowell and RTD)
P1	Pipe Ends: NPT threaded
P2	Pipe Ends: Beveled
A1	Pipe Ends: Flanged, RF, ANSI Class 150, slip-on
A3	Pipe Ends: Flanged, RF, ANSI Class 300, slip-on
A6	Pipe Ends: Flanged, RF, ANSI Class 600, slip-on
D1	Pipe Ends: Flanged, RF, DIN PN16, slip-on
D2	Pipe Ends: Flanged, RF, DIN PN40, slip-on
D3	Pipe Ends: Flanged, RF, DIN PN100, slip-on
W1	Pipe Ends: Flanged, RF, ANSI Class 150, weld-neck
W3	Pipe Ends: Flanged, RF, ANSI Class 300, weld-neck
W6	Pipe Ends: Flanged, RF, ANSI Class 600, weld-neck
R1	Pipe Ends: Flanged, RTJ, ANSI Class 150, slip-on
R3	Pipe Ends: Flanged, RTJ, ANSI Class 300, slip-on
R6	Pipe Ends: Flanged, RTJ, ANSI Class 600, slip-on
P9	Special process connections
Code	Orifice Plate Material
S	316 SST
H	<i>Hastelloy C-276</i>
M	<i>Monel</i>
Code	Bore Size Option
0010	0.010-in. (0.25 mm) for 1/2-in. pipe
0014	0.014-in. (0.36 mm) for 1/2-in. pipe
0020	0.020-in. (0.51 mm) for 1/2-in. pipe
0034	0.034-in. (0.86 mm) for 1/2-in. pipe
0066	0.066-in. (1.68 mm) for 1/2-in. pipe
0109	0.109-in. (2.77 mm) for 1/2-in. pipe
0160 ⁽²⁾	0.160-in. (4.06 mm) for 1/2-in. pipe
0196 ⁽²⁾	0.196-in. (4.98 mm) for 1/2-in. pipe
0260 ⁽²⁾	0.260-in. (6.60 mm) for 1/2-in. pipe
0340 ⁽²⁾	0.340-in. (8.64 mm) for 1/2-in. pipe
0150	0.150-in. (3.81 mm) for 1-in. pipe
0250 ⁽²⁾	0.250-in. (6.35 mm) for 1-in. pipe
0345 ⁽²⁾	0.345-in. (8.76 mm) for 1-in. pipe
0500 ⁽²⁾	0.500-in. (12.70 mm) for 1-in. pipe
0630 ⁽²⁾	0.630-in. (16.00 mm) for 1-in. pipe
0800	0.800-in. (20.32 mm) for 1-in. pipe
0295	0.295-in. (7.49 mm) for 1 1/2-in. pipe
0376 ⁽²⁾	0.376-in. (9.55 mm) for 1 1/2-in. pipe
0512 ⁽²⁾	0.512-in. (13.00 mm) for 1 1/2-in. pipe

Rosemount Integral Orifice Flowmeter Series

Product Data Sheet
00813-0100-4686, Rev NA
March 2008

Rosemount 3051SFP Proplate Flowmeter Ordering Information

0748 ⁽²⁾	0.748-in. (19.00 mm) for 1 ¹ / ₂ -in. pipe		
1022	1.022-in. (25.96 mm) for 1 ¹ / ₂ -in. pipe		
1184	1.184-in. (30.07 mm) for 1 ¹ / ₂ -in. pipe		
Code	Transmitter Connection Platform		
D3	Direct-mount, 3-valve manifold, SST		
D4	Direct-mount, 3-valve manifold, <i>Hastelloy-C</i>		
D5	Direct-mount, 5-valve manifold, SST		
D6	Direct-mount, 5-valve manifold, <i>Hastelloy-C</i>		
D7	Direct-mount, High Temperature, 5-valve manifold, SST		
R3	Remote-mount, 3-valve manifold, SST		
R4	Remote-mount, 3-valve manifold, <i>Hastelloy-C</i>		
R5	Remote-mount, 5-valve manifold, SST		
R6	Remote-mount, 5-valve manifold, <i>Hastelloy-C</i>		
Code	Differential Pressure Range		
1A	0 to 25 in H ₂ O (0 to 62.2 mbar)		
2A	0 to 250 in H ₂ O (0 to 623 mbar)		
3A	0 to 1000 in H ₂ O (0 to 2.5 bar)		
Code	Output Protocol		
A	4–20 mA with digital signal based on <i>HART</i> protocol		
F ⁽³⁾	<i>FOUNDATION</i> fieldbus: AI block, Link Master, Input Selector Block		
X ⁽⁴⁾	Wireless (Requires wireless options and wireless housing 5A)		
Code	Transmitter Housing Style	Material	Conduit Entry Size
1A	PlantWeb Housing	Aluminum	1/2-14 NPT
1B	PlantWeb Housing	Aluminum	M20 x 1.5 (CM20)
1C	PlantWeb Housing	Aluminum	G ¹ / ₂
1J	PlantWeb Housing	316L SST	1/2-14 NPT
1K	PlantWeb Housing	316L SST	M20 x 1.5 (CM20)
1L	PlantWeb Housing	316L SST	G ¹ / ₂
5A	Wireless PlantWeb Housing	Aluminum	1/2-14 NPT
2A	Junction Box Housing	Aluminum	1/2-14 NPT
2B	Junction Box Housing	Aluminum	M20 x 1.5 (CM20)
2C	Junction Box Housing	Aluminum	G ¹ / ₂
2E	Junction Box Housing with output for remote display and interface	Aluminum	1/2-14 NPT
2F	Junction Box Housing with output for remote display and interface	Aluminum	M20 x 1.5 (CM20)
2G	Junction Box Housing with output for remote display and interface	Aluminum	G ¹ / ₂
2J	Junction Box Housing	316L SST	1/2-14 NPT
2M	Junction Box Housing with output for remote display and interface	316L SST	1/2-14 NPT
7J ⁽⁵⁾	Quick Connect (A size Mini, 4-pin male termination)	316L SST	
Code	Performance Class		
3 ⁽⁶⁾	Ultra for Flow: up to ±0.95% flow rate accuracy, 14:1 flow turndown, 10-year stability, limited 12-year warranty		
1 ⁽⁶⁾	Ultra: up to ±1.05% flow rate accuracy, 8:1 flow turndown, 10-year stability, limited 12-year warranty		
2	Classic: up to ±1.20% flow rate accuracy, 8:1 flow turndown, 5-year stability		
Code	Wireless Options - Select code from each wireless category (example: WA2WK1)		
Wireless Transmit Rate			
WA	User Configurable Transmit Rate		
Operating Frequency and Protocol			
1	2.4 GHz DSSS, HART		
2	900 MHz FHSS, HART		
Antenna			
WK	Omnidirectional, Integral Antenna		
SmartPower™			
1	Long-life Power Module Adapter, Intrinsically Safe NOTE: Long-life Power Module must be shipped separately, order Part No. 00753-9220-0001.		

Rosemount 3051SFP Proplate Flowmeter Ordering Information

Code	Options
High Temperature Materials	
G	High temperature Option (850 °F (454 °C))
Temperature Sensor	
T ⁽⁷⁾	Thermowell and RTD
Optional Connection	
G1	DIN 19231 Transmitter Connection
Pressure Testing	
P1 ⁽⁸⁾	Hydrostatic Testing
Special Cleaning	
P2	Cleaning for special processes
PA	Cleaning per ASTM G93 Level D (section 11.4)
Material Testing	
V1	Dye Penetrant Exam
Material Examination	
V2	Radiographic Examination (available only with Process Connection code W1, W3, and W6)
Flow Calibration	
WD ⁽⁹⁾	Discharge Coefficient Verification
WZ ⁽⁹⁾	Special Calibration
Special Inspection	
QC1	Visual and dimensional inspection with certificate
QC7	Inspection and performance certificate
Material Traceability Certification	
Q8 ⁽¹⁰⁾	Material certification per ISO 10474 3.1.B and EN 10204 3.1.B
Code Conformance	
J2 ⁽¹¹⁾	ANSI / ASME B31.1
J3 ⁽¹¹⁾	ANSI / ASME B31.3
Materials Conformance	
J5 ⁽¹²⁾	NACE MR-0175 / ISO 15156
Country Certification	
J1	Canadian Registration
J6	European Pressure Directive (PED)
Transmitter Calibration Certification	
Q4	Calibration Data Certificate for Transmitter
QP	Calibration Data Certificate and Tamper Evident Seal
Special Certification	
QS ⁽⁶⁾	Prior-use certificate for FMEDA data
QT ⁽¹³⁾	Safety-certified to IEC 61508 with certificate of FMEDA data
Product Certifications	
E1	ATEX Flameproof
I1	ATEX Intrinsic Safety
IE	FM FISCO Intrinsically Safe; for FOUNDATION fieldbus protocol only
IF	CSA FISCO Intrinsically Safe; for FOUNDATION fieldbus protocol only
IA ⁽¹⁴⁾	ATEX FISCO Intrinsic Safety; for FOUNDATION fieldbus protocol only
N1	ATEX Type n
ND	ATEX Dust
K1	ATEX Flameproof, Intrinsic Safety, Type n, Dust (combination of E1, I1, N1, and ND)
E4	TIIS Flameproof
E5	FM Explosion-proof, Dust Ignition-proof
I5	FM Intrinsically Safe, Division 2
K5	FM Explosion-proof, Dust Ignition-proof, Intrinsically Safe, Division 2 (combination of E5 and I5)
E6	CSA Explosion-proof, Dust Ignition-proof, Division 2
I6	CSA Intrinsically Safe
K6	CSA Explosion-proof, Dust Ignition-proof, Intrinsically Safe, Division 2 (combination of E6 and I6)
E7 ⁽¹⁴⁾	SAA Flameproof, Dust Ignition-proof
I7	IECEx Intrinsic Safety

Rosemount 3051SFP Proplate Flowmeter Ordering Information

N7	IECEX Type n
K7	SAA Flameproof, Dust Ignition-proof, IECEX Intrinsic Safety, Type n (combination of E7, I7, and N7)
KA	ATEX and CSA Flameproof, Intrinsically Safe, Division 2 (combination of E1, I1, E6, and I6) <i>Note: Only available on Housing Style codes 1A, 1J, 2A, 2J, 2E, or 2M.</i>
KB	FM and CSA Explosion-proof, Dust Ignition-proof, Intrinsically Safe, Division 2 (combination of E5, E6, I5, and I6) <i>Note: Only available on Housing Style codes 1A, 1J, 2A, 2J, 2E, or 2M.</i>
KC	FM and ATEX Explosion-proof, Intrinsically Safe, Division 2 (combination of E5, E1, I5, and I1) <i>Note: Only available on Housing Style codes 1A, 1J, 2A, 2J, 2E, or 2M.</i>
KD	FM, CSA, and ATEX Explosion-proof, Intrinsically Safe (combination of E5, I5, E6, I6, E1, and I1) <i>Note: Only available on Housing Style codes 1A, 1J, 2A, 2J, 2E, or 2M.</i>

Alternative Transmitter Material of Construction

L1	Inert Sensor Fill Fluid
L2	Graphite-filled PTFE o-ring
LA	Inert sensor fill fluid and graphite-filled PTFE o-ring

Display⁽¹⁵⁾

M5	<i>PlantWeb</i> LCD display
M7 ⁽⁶⁾⁽¹⁶⁾	Remote mount LCD display and interface, <i>PlantWeb</i> housing, no cable, SST bracket
M8 ⁽⁶⁾⁽¹⁶⁾	Remote mount LCD display and interface, <i>PlantWeb</i> housing, 50 foot cable, SST bracket
M9 ⁽⁶⁾⁽¹⁶⁾	Remote mount LCD display and interface, <i>PlantWeb</i> housing, 100 foot cable, SST bracket

Terminal Blocks

T1 ⁽¹⁷⁾	Transient terminal block
T2 ⁽¹⁸⁾	Terminal block with WAGO [®] spring clamp terminals
T3 ⁽¹⁸⁾	Transient terminal block with WAGO spring clamp terminals

PlantWeb Control Functionality

A01 ⁽¹⁹⁾	FOUNDATION fieldbus Advanced Control Function Block Suite
---------------------	---

PlantWeb Diagnostic Functionality

D01 ⁽¹⁹⁾	FOUNDATION fieldbus Diagnostics Suite
DA1 ⁽²⁰⁾	HART Diagnostics Suite

PlantWeb Enhanced Measurement Functionality

H01 ⁽¹⁹⁾⁽²¹⁾	Fully Compensated Mass Flow Block
-------------------------	-----------------------------------

Alarm Limits

C4 ⁽⁶⁾⁽²²⁾	NAMUR alarm and saturation signal levels, high alarm
C5 ⁽⁶⁾⁽²²⁾	NAMUR alarm and saturation signal levels, low alarm
C6 ⁽⁶⁾⁽²²⁾	Custom alarm and saturation signal levels, high alarm <i>Note: A Configuration Data Sheet must be completed, see document number 00806-0100-4686.</i>
C7 ⁽⁶⁾⁽²²⁾	Custom alarm and saturation signal levels, low alarm <i>Note: A Configuration Data Sheet must be completed, see document number 00806-0100-4686..</i>
C8 ⁽⁶⁾⁽²²⁾	Low alarm (standard Rosemount alarm and saturation signal levels)

Special Configuration (Hardware)

D1 ⁽²²⁾	Hardware Adjustment (zero, span, alarm, security)
D4	External ground screw
DA ⁽²²⁾	Hardware adjustment (zero, span, security) and external ground screw

Conduit Electrical Connector

GE ⁽²³⁾	M12, 4-pin, Male Connector (<i>euromast</i> [®])
GM ⁽²³⁾	A size Mini, 4-pin, Male Connector (<i>minifast</i> [®])

Typical Model Number: 3051SFP D S 010 A3 S 0150 D3 1A A 1A 3

- (1) To improve pipe perpendicularity for gasket sealing, socket diameter is smaller than standard pipe O.D.
- (2) Best flow coefficient uncertainty is between $(0.2 < \beta < 0.6)$.
- (3) Requires *PlantWeb* housing.
- (4) Available approvals are FM Intrinsically Safe, Division 2 (option code I5), CSA Intrinsically Safe (option code I6), ATEX Intrinsic Safety (option code I1; only available with 2.4 GHz), and IECEX Intrinsic Safety (option code I7; only available with 2.4 GHz).
- (5) Available with output code A only. Available approvals are FM Intrinsically Safe, Division 2 (option code I5) or ATEX Intrinsic Safety (option code I1). Contact an Emerson Process Management representative for additional information.
- (6) Not available with Output Protocol code X.

- (7) *Thermowell material is the same as the body material.*
- (8) *Does not apply to Process Connection codes T1 and S1.*
- (9) *Not available for bore sizes 0010, 0014, 0020, or 0034.*
- (10) *Includes certificates for mechanical and chemical properties of bodies, orifice plates, pipes, flanges, and adapters as applicable.*
- (11) *Not available with DIN Process Connection codes D1, D2, or D3.*
- (12) *Materials of Construction comply with metallurgical requirements within NACE MR0175/ISO for sour oil field production environments. Environmental limits apply to certain materials. Consult latest standard for details. Selected materials also conform to NACE MR0103 for sour refining environments.*
- (13) *Not available with output code F or X. Not available with housing code 7J.*
- (14) *Consult factory for availability.*
- (15) *Not available with Housing code 7J.*
- (16) *Not available for Output Protocol code F, option code DA1, or option code QT.*
- (17) *Not available with Housing code 5A or 7J.*
- (18) *Available with Output Protocol code A and PlantWeb housing only.*
- (19) *Requires PlantWeb housing and output code F.*
- (20) *Requires PlantWeb housing and Output code A. Includes Hardware Adjustments as standard. Contact an Emerson Process Management representative regarding availability.*
- (21) *Requires Rosemount Engineering Assistant to configure.*
- (22) *Not available with Output Protocol code F.*
- (23) *Not available with Housing code 7J. Available with Intrinsically Safe approvals only. For FM Intrinsically Safe, Division 2 (option code I5) or FM FISCO Intrinsically Safe (option code IE), install in accordance with Rosemount drawing 03151-1009 to maintain NEMA 4X rating.*

Rosemount 3095MFP Mass Proplate Flowmeter

SPECIFICATIONS

Performance

System Reference Accuracy

Percentage (%) of mass flow rate⁽¹⁾

Beta (β) ⁽²⁾	Classic (8:1 flow turndown)	Ultra for Flow 10:1 flow turndown
$\beta < 0.1$	±2.60%	±2.55%
$0.1 < \beta < 0.2$	±1.50%	±1.35%
$0.2 < \beta < 0.6$	±1.10%	±0.95%
$0.6 < \beta < 0.8$	±1.70%	±1.60%

(1) Without associated straight run piping, discharge coefficient uncertainty can add up to 1.5% - 5% additional error. Consult the factory for additional information.

(2) $\beta = \frac{\text{Orifice Plate Bore}}{\text{body I.D.}}$

Repeatability

±0.1%

Line Sizes

- 1/2-in. (15 mm)
- 1-in. (25 mm)
- 1 1/2-in. (40 mm)

Output

Two-wire 4–20 mA, user-selectable for DP, AP, GP, PT, mass flow, or totalized flow. Digital HART protocol superimposed on 4–20 mA signal, available to any host that conforms to the HART protocol.

Performance Statement Assumptions

- Measured pipe I.D.
- Electronics are trimmed for optimum flow accuracy

Sizing

Contact a Emerson Process Management sales representative for assistance. A “Configuration Data Sheet” is required prior to order for application verification.

Functional

Service

- Liquid
- Gas
- Steam

Power Supply

4–20 mA option

- External power supply required. Standard transmitter (4–20 mA) operates on 11 to 55 v dc with no load

Process Temperature Limits

Direct Mount Transmitter

- –40 to 450 °F (–40 to 232 °C)

Remote Mount Transmitter

- –148 to 850 °F (–100 to 454 °C)⁽¹⁾

(1) High temperature option code G must be selected.

Transmitter Temperature Limits

Ambient

- –40 to 185 °F (–40 to 85 °C)
- With Integral Mount LCD Display: –4 to 175 °F (–20 to 80 °C)

Storage

- –50 to 230 °F (–46 to 110 °C)
- With Integral Mount LCD Display: –40 to 185 °F (–40 to 85 °C)

Maximum Working Pressure

Transmitter

- Zero to two times the absolute pressure range with a maximum of 3626 psia (250 bar).

Flowmeter

- Pressure retention per ANSI B16.5 600 lb. or DIN PN100

TABLE 5. 1195 Pressure Limits

Line Size	Process Connection Code	Maximum Working Pressure @ 100 °F ⁽¹⁾⁽²⁾
1/2-in. (12.7 mm)	S1 or P2	3000 psig (207 bar)
	T1 or P1	1500 psig (103 bar)
1-in. (25.4 mm)	S1 or P2	2000 psig (138 bar)
	T1 or P1	1500 psig (103 bar)
1 1/2-in. (38.1 mm)	S1 or P2	1500 psig (103 bar)
	T1 or P1	1500 psig (103 bar)
All	Flanged	Meets flange primary pressure rating per ANSI B16.5 (EN-1092-1 for DIN flanges)

(1) For pressure ratings at temperatures less than –20 °F (–29 °C) or above 100 °F (38 °C) consult an Emerson Process Management representative.

(2) Transmitter static pressure range may limit maximum working pressure. Refer to Static Pressure Ranges specification.

Static Pressure Limits

Operates within specification between static pressures of 0.5 psia (0.03 bar-A) and the URL of the static pressure sensor.

Load Limitations

Maximum loop resistance is determined by the voltage level of the external power supply, as described by:

$$\text{Maximum Loop Resistance} = \frac{\text{Power Supply} - 11.0}{0.022}$$

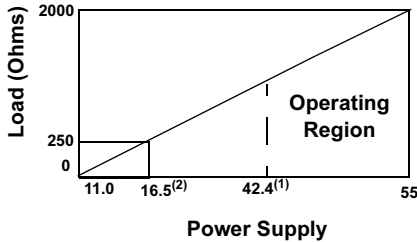

- (1) For CSA approval, power supply must not exceed 42.4 V dc.
- (2) HART protocol communication requires a loop resistance value between 250-1100 ohms, inclusive.

Humidity Limits

- 0–100% relative humidity

Turn-On Time

Digital and analog measured variables will be within specification 7 – 10 seconds after power is applied to the transmitter.
Digital and analog flow output will be within specifications 10 – 14 seconds after power is applied to the transmitter.

Damping

Analog output response to a step input change is user-selectable from 0 to 29 seconds for one time constant. This software damping is in addition to sensor module response time

Failure Mode Alarm

Output Code A

If self-diagnostics detect a non-recoverable transmitter failure, the analog signal will be driven either below 3.75 mA or above 21.75 mA to alert the user. High or low alarm signal is user-selectable by internal jumper pins.

Output Code V

If self-diagnostics detect a gross transmitter failure, that information gets passed as a status along with the process variable(s).

Configuration

- HART Hand-held Communicator (Model 275 or 375)
 - Performs traditional transmitter maintenance functions
- 3095 Multivariable Engineering Assistant (EA) software package
 - Contains built-in physical property database
 - Enables mass flow configuration, maintenance, and diagnostic functions via HART modem (output option code A)
- Enables mass flow configuration via PCMCIA Interface for FOUNDATION fieldbus (output option code V)

Physical Properties Database

- Maintained in Engineering Assistant Software Configurator
- Physical properties for over 110 fluids
- Natural gas per AGA
- Steam and water per ASME
- Other database fluids per American Institute of Chemical Engineers (AIChE)
- Optional custom entry

FOUNDATION fieldbus Function Blocks

Standard Function Blocks

- Resource Block
 - Contains hardware, electronics, and diagnostic information.
- Transducer Block
 - Contains actual sensor measurement data including the sensor diagnostics and the ability to trim the pressure sensor or recall factory defaults.

LCD Block

- Configures the local display.

5 Analog Input Blocks

- Processes the measurements for input into other function blocks. The output value is in engineering or custom units and contains a status indicating measurement quality.

PID Block with Auto-tune

- Contains all logic to perform PID control in the field including cascade and feedforward. Auto-tune capability allows for superior tuning for optimized control performance.

Advanced Control Function Block Suite (Option Code A01)

Input Selector Block

- Selects between inputs and generates an output using specific selection strategies such as minimum, maximum, midpoint, average, or first “good.”

Arithmetic Block

- Provides pre-defined application-based equations including flow with partial density compensation, electronic remote seals, hydrostatic tank gauging, ratio control and others.

Signal Characterizer Block

- Characterizes or approximates any function that defines an input/output relationship by configuring up to twenty X, Y coordinates. The block interpolates an output value for a given input value using the curve defined by the configured coordinates.

Integrator Block

- Compares the integrated or accumulated value from one or two variables to pre-trip and trip limits and generates discrete output signals when the limits are reached. This block is useful for calculating total flow, total mass, or volume over time.

Output Splitter Block

- Splits the output of one PID or other control block so that the PID will control two valves or other actuators.

Control Selector Block

- Selects one of up to three inputs (highest, middle, or lowest) that are normally connected to the outputs of PID or other control function blocks.

Rosemount Integral Orifice Flowmeter Series

Product Data Sheet
00813-0100-4686, Rev NA
March 2008

Physical

Temperature Measurement

Remote RTD

- 100 Ohm platinum with 1/2-in. NPT nipple and union (078 series with Rosemount 644 housing)
- Standard RTD cable is shielded armored cable, length is 12 feet (3.66 m)
- Remote RTD material is SST

Thermowell

- 1/2-in. x 1/2-in. NPT, 316 SST

Electrical Considerations

1/2–14 NPT, G1/2, and CM20 conduit. HART interface connections permanently fixed to terminal block

Material of Construction

Orifice Plate

- 316/316L SST
- Hastelloy C-276
- Monel 400

Body

- 316 SST (CF8M), material per ASTM A351
- Hastelloy C-276 (CW12MW), material per ASTM A494

Flange and Pipe Material (If Applicable)

- A312 Gr 316/316L, B622 UNS N10276
- Flange pressure limits are per ANSI B16.5
- Flange face finish per ANSI B16.5, 125 to 250 RMS

Body Bolts/Studs

- ASTM A193 Gr B8M studs
- SAE J429 Gr 8 bolts (meets or exceeds ASTM A193 B7 requirements) for body bolt/stud material option code G for high temperatures.

Transmitter Connection Studs

- ASTM A193 Gr B8M studs

Gaskets/O-rings

- Glass filled PTFE
- Optional high temperature Inconel® X-750
- Gaskets and o-rings must be replaced each time the 3095MFP is disassembled for installation or maintenance.

Orifice Type

Square edged—orifice bore size

- 0.066-in and larger

Quadrant edged—orifice bore size (for 1/2-in. line size only)

- 0.034-in
- 0.020-in
- 0.014-in
- 0.010-in

NOTE

Integral Orifice bodies contain corner tapped pressure ports.

Pipe Lengths

- Upstream and downstream associated piping sections are available on the 1195. The table below lists the standard overall length (lay length) as a function of end connections and line size.

Flanged Process Connection ^{(1) (2) (3)}	Line Size		
	1/2-in. (15 mm)	1-in. (25 mm)	1 1/2-in. (40 mm)
RF, ANSI Class 150, slip-on	18.2 (463)	28.9 (734)	40.3 (1023)
RF, ANSI Class 300, slip-on	18.2 (463)	28.9 (734)	40.3 (1023)
RF, ANSI Class 600, slip-on	18.2 (463)	28.9 (734)	40.3 (1023)
RF, DIN PN16, slip-on	18.2 (463)	28.9 (734)	40.3 (1023)
RF, DIN PN40, slip-on	18.2 (463)	28.9 (734)	40.3 (1023)
RF, DIN PN100, slip-on	18.2 (463)	28.9 (734)	40.3 (1023)
RF, ANSI Class 150, weld-neck	21.8 (554)	33.2 (843)	44.9 (1140)
RF, ANSI Class 300, weld-neck	22.2 (564)	33.7 (856)	45.5 (1156)
RF, ANSI Class 600, weld-neck	22.8 (579)	34.3 (871)	46.1 (1171)
RTJ, ANSI Class 150, slip-on	18.2 (463)	28.9 (734)	40.3 (1023)
RTJ, ANSI Class 300, slip-on	18.2 (463)	28.9 (734)	40.3 (1023)
RTJ, ANSI Class 600, slip-on	18.2 (463)	28.9 (734)	40.3 (1023)
NPT / Beveled Process Connection⁽¹⁾⁽²⁾⁽³⁾	18 (457)	28.9 (734)	40.3 (1023)

(1) See the ordering information for model code description.

(2) Consult factory for other lengths.

(3) See page 37 for additional information on associated pipe lengths.

Weight

The following weights are approximate

Line Size	With Body		With Flanged Piping ⁽¹⁾	
	lb	kg	lb	kg
1/2-in. (15 mm)	16.1	7.3	20.1	9.1
1-in. (25 mm)	18.1	8.2	24.1	10.9
1 1/2-in. (40 mm)	20.1	9.1	37.1	16.8

(1) As supplied with standard lengths, ANSI Class 150 flanges.

Installation Considerations

Pipe Orientation

Orientation/ Flow Direction	Process ⁽¹⁾		
	Gas	Liquid	Steam
Horizontal	D/R	D/R	D/R
Vertical Up	R	R	R
Vertical Down	R	NR	NR

(1) D = Direct mount acceptable (recommended)
 R = Remote mount acceptable
 NR = Not recommended

Flowmeter Orientation

Gas (Horizontal)

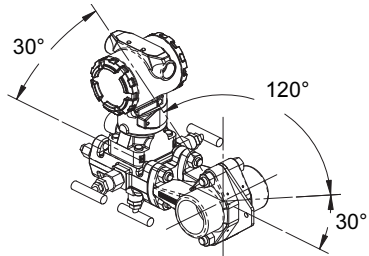

Liquid and Steam (Horizontal)

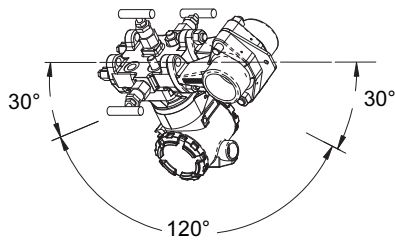

Gas (Vertical)

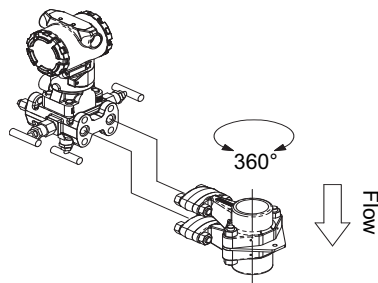

Liquid (Vertical)

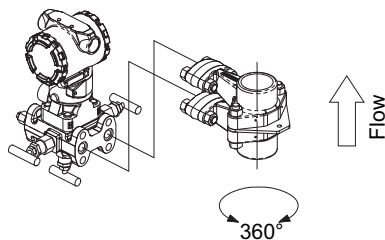

Process-Wetted Parts

Integral Manifolds

- 316 SST
- Hastelloy C-276

Remote Manifolds

- 316 SST
- Hastelloy C-276

Transmitter Vent Valves and Process Flanges

- 316 SST
- Hastelloy C-276

Process Isolating Diaphragms

- 316L SST
- Hastelloy C-276

O-rings

- Glass-filled PTFE / Inconel X-750

Integral Manifold O-Rings

- PTFE / Graphite (D7)

Non-Wetted Parts

Sensor Module Fill Fluid

- Silicone oil
- Inert Fill optional

Cover O-rings

- Buna-N

Remote Mounting Brackets

- SST

Sensor mounting (including nuts, bolts, and gasket)

- SST

Electronic Housing

- Low copper aluminum, NEMA 4x, IP65
- SST (optional)

Paint

- Polyurethane

Bolts

- SST

PRODUCT CERTIFICATIONS

Rosemount 3095 with HART

European Directive Information

The EC declaration of conformity for all applicable European directives for this product can be found on the Rosemount website at www.rosemount.com. A hard copy may be obtained by contacting our local sales office.

ATEX Directive (94/9/EC)

Emerson Process Management complies with the ATEX Directive.

European Pressure Equipment Directive (PED) (97/23/EC)

3095M_2/3,4/D Flow Transmitters — QS Certificate of Assessment - EC No. PED-H-20
Module H Conformity Assessment

All other 3095_ Transmitters/Level Controller —
Sound Engineering Practice

Transmitter Attachments: Process Flange - Manifold —
Sound Engineering Practice

Electro Magnetic Compatibility (EMC) (89/336/EEC)

3095MV Flow Transmitters
— EN 50081-1: 1992; EN 50082-2:1995;
EN 61326-1:1997 – Industrial

Ordinary Location Certification for Factory Mutual

As standard, the transmitter has been examined and tested to determine that the design meets basic electrical, mechanical, and fire protection requirements by FM, a nationally recognized testing laboratory (NRTL) as accredited by the Federal Occupational Safety and Health Administration (OSHA).

Hazardous Locations Certifications

North American Certifications

FM Approvals

- E5 Explosion Proof for Class I, Division 1, Groups B, C, and D. Dust-Ignition Proof for Class II/Class III, Division 1, Groups E, F, and G. Enclosure type NEMA 4X. Factory Sealed. Provides nonincendive RTD connections for Class I, Division 2, Groups A, B, C, and D.
- I5 Intrinsically Safe for use in Class I, II and III, Division 1, Groups A, B, C, D, E, F, and G hazardous outdoor locations. Non-incendive for Class I, Division 2, Groups A, B, C, and D. Temperature Code T4. Factory Sealed.
- For input parameters and installation see control drawing 03095-1020.

Canadian Standards Association (CSA)

- E6 Explosion Proof for Class I, Division 1, Groups B, C, and D. Dust-Ignition Proof for Class II/Class III, Division 1, Groups E, F, and G. CSA enclosure Type 4X suitable for indoor and outdoor hazardous locations. Provides nonincendive RTD connection for Class I, Division 2, Groups A, B, C, and D. Factory Sealed. Install in accordance with Rosemount Drawing 03095-1024. Approved for Class I, Division 2, Groups A, B, C, and D.
- I6 Intrinsically Safe for Class I, Division 1, Groups A, B, C, and D. when installed in accordance with Rosemount drawing 03095-1021. Temperature Code T3C.
- For input parameters and installation see control drawing 03095-1021.

European Certifications

- I1 ATEX Intrinsic Safety
Certificate Number: BAS98ATEX1359X  II 1 G
EEx ia IIC T5 ($T_{amb} = -45\text{ °C to }40\text{ °C}$)
EEx ia IIC T4 ($T_{amb} = -45\text{ °C to }70\text{ °C}$)
CE 1180

TABLE 6. Connection Parameters (Power/Signal Terminals)

$U_i = 30V$
$I_i = 200\text{ mA}$
$P_i = 1.0\text{ W}$
$C_i = 0.012\text{ }\mu\text{F}$
$L_i = 0$

TABLE 7. Temperature Sensor Connection Parameters

$U_o = 30V$
$I_o = 19\text{ mA}$
$P_o = 140\text{ mW}$
$C_i = 0.002\text{ }\mu\text{F}$
$L_i = 0$

TABLE 8. Temp Sensor Terminals Connection Parameters

$C_o = 0.066\text{ }\mu\text{F}$	Gas Group IIC
$C_o = 0.560\text{ }\mu\text{F}$	Gas Group IIB
$C_o = 1.82\text{ }\mu\text{F}$	Gas Group IIA
$L_o = 96\text{ mH}$	Gas Group IIC
$L_o = 365\text{ mH}$	Gas Group IIB
$L_o = 696\text{ mH}$	Gas Group IIA
$L_o/R_o = 247\text{ }\mu\text{H}/\text{ohm}$	Gas Group IIC
$L_o/R_o = 633\text{ }\mu\text{H}/\text{ohm}$	Gas Group IIB
$L_o/R_o = 633\text{ }\mu\text{H}/\text{ohm}$	Gas Group IIA

Special Conditions for Safe Use

The 3095, when fitted with the transient terminal block (order code B), are not capable of withstanding the 500 volts insulation test required by EN50 020, Clause 6.4.12 (1994). This condition must be accounted for during installation.

- N1 ATEX Type N
Certificate Number: BAS98ATEX3360X  II 3 G
EEx nL IIC T5 ($T_{amb} = -45\text{ °C to }40\text{ °C}$)
EEx nL IIC T4 ($T_{amb} = -45\text{ °C to }70\text{ °C}$)
 $U_i = 55V$
CE
The apparatus is designed for connection to a remote temperature sensor such as a resistance temperature detection (RTD)

Special Conditions for Safe Use

The 3095, when fitted with the transient terminal block (order code B), are not capable of withstanding the 500 volts insulation test required by EN50 021, Clause 9.1 (1995). This condition must be accounted for during installation.

- E1 ATEX Flameproof
Certificate Number: KEMA02ATEX2320X  II 1/2 G
EEx d IIC T5 (-50°C ≤ T_{amb} ≤ 80°C)
T6 (-50°C ≤ T_{amb} ≤ 65°C)
CE 1180

Special Conditions for Safe Use (x):

The device contains a thin wall diaphragm. Installation, maintenance, and use shall take into account the environmental conditions to which the diaphragm will be subjected. The manufacturer's instructions for installation and maintenance shall be followed in detail to assure safety during its expected lifetime.

- ND ATEX Dust
Certificate Number: KEMA02ATEX2321  II 1 D
V = 55 Vdc MAX
I = 23 mA MAX
IP66
CE 1180

Combinations of Certifications

Stainless steel certification tag is provided when optional approval is specified. Once a device labeled with multiple approval types is installed, it should not be reinstalled using any other approval types. Permanently mark the approval label to distinguish it from unused approval types.

- K5 E5 and I5 combination
K6 E6 and I6 combination
K1 I1, N1, E1, and ND combination

Rosemount 3095 with *Fieldbus*

European Directive Information

The EC declaration of conformity for all applicable European directives for this product can be found on the Rosemount website at www.rosemount.com. A hard copy may be obtained by contacting our local sales office.

ATEX Directive (94/9/EC)

Emerson Process Management complies with the ATEX Directive.

European Pressure Equipment Directive (PED) (97/23/EC)

3095F_2/3,4/D and 3095M_2/3,4/D Flow Transmitters
— QS Certificate of Assessment - EC No. PED-H-20
Module H Conformity Assessment
All other 3095_ Transmitters/Level Controller
— Sound Engineering Practice
Transmitter Attachments: Process Flange - Manifold
— Sound Engineering Practice
Primary Elements, Flowmeter
— See appropriate Primary Element QIG

Electro Magnetic Compatibility (EMC) (89/336/EEC)

3095 Flow Transmitters

— EN 50081-1: 1992; EN 50082-2:1995; EN 61326-1:1997 –
Industrial

Ordinary Location Certification for Factory Mutual

As standard, the transmitter has been examined and tested to determine that the design meets basic electrical, mechanical, and fire protection requirements by FM, a nationally recognized testing laboratory (NRTL) as accredited by the Federal Occupational Safety and Health Administration (OSHA).

Rosemount 3095 Fieldbus Hazardous Locations Certifications

North American Certifications

FM Approvals

- E5 Explosion Proof for Class I, Division 1, Groups B, C, and D. Dust-Ignition Proof for Class II/Class III, Division 1, Groups E, F, and G. Enclosure type NEMA 4X. Factory Sealed. Provides nonincendive RTD connections for Class I, Division 2, Groups A, B, C, and D.
- I5 Intrinsically Safe for use in Class I, II and III, Division 1, Groups A, B, C, D, E, F, and G hazardous outdoor locations. Non-incendive for Class I, Division 2, Groups A, B, C, and D. Temperature Code T4. Factory Sealed.

For input parameters and installation see control drawing 03095-1020.

- IE FISCO for use in Class I, II and III, Division 1, Groups A, B, C, D, E, F, and G hazardous outdoor locations. Temperature Code T4. Factory Sealed.

For input parameters and installation see control drawing 03095-1020.

Combinations of Certifications

Stainless steel certification tag is provided when optional approval is specified. Once a device labeled with multiple approval types is installed, it should not be reinstalled using any other approval types. Permanently mark the approval label to distinguish it from unused approval types.

- K5 E5 and I5 combination

Canadian Standards Association (CSA)

- IF CSA FISCO Intrinsically Safe; for FOUNDATION fieldbus protocol only

European Certifications

- IA ATEX FISCO Intrinsically Safe; for FOUNDATION fieldbus protocol only

Australian Certifications

- IG IECEx FISCO Intrinsic Safety

Rosemount Integral Orifice Flowmeter Series

Product Data Sheet
00813-0100-4686, Rev NA
March 2008

DIMENSIONAL DRAWINGS

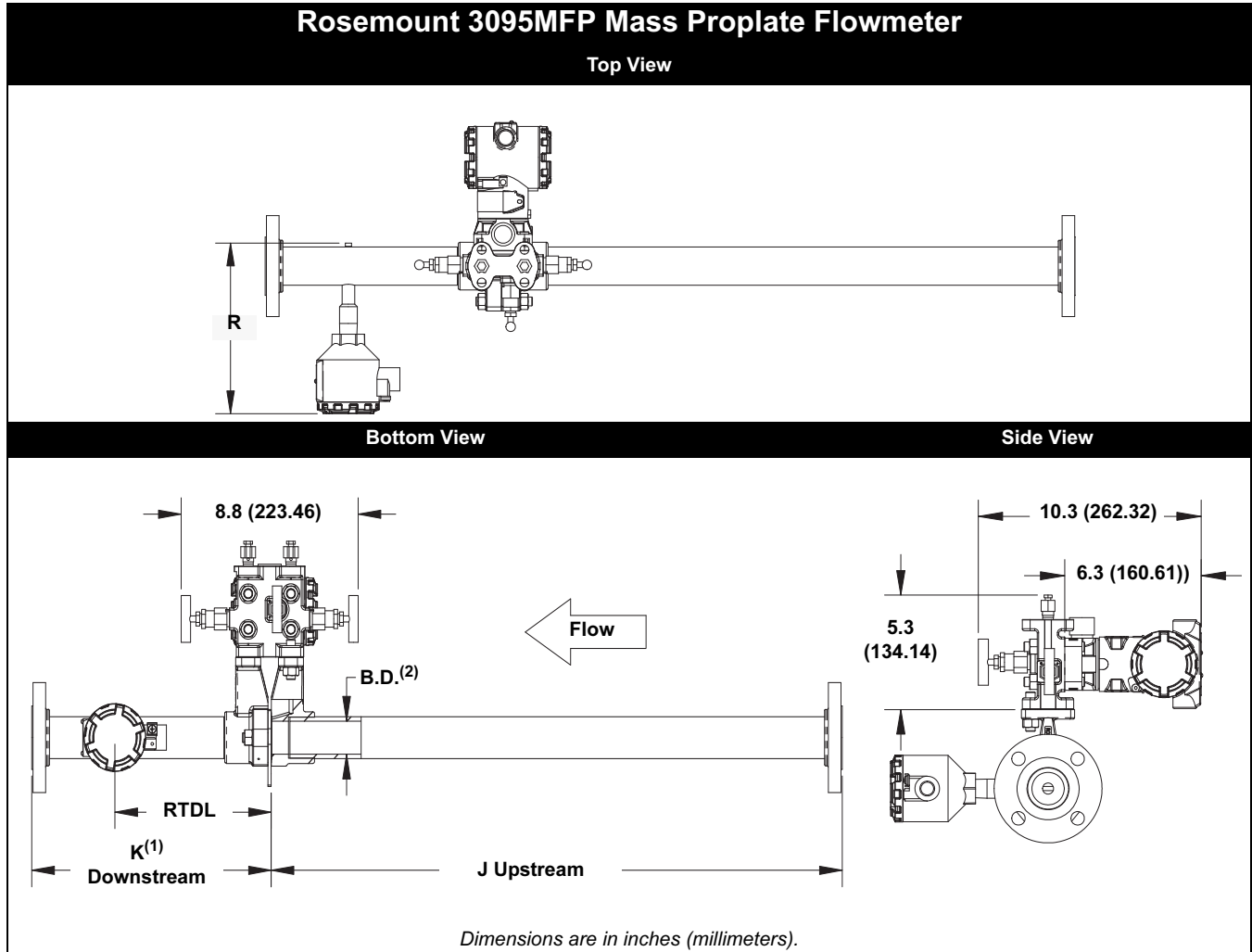

Dimension	Line Size					
	1/2-in. (12.7 mm)		1-in. (25.4 mm)		1 1/2-in. (38.1 mm)	
J (RF slip-on, RTJ slip-on, RF-DIN slip-on)	12.5-in.	318 mm	20.2-in.	513 mm	28.4-in.	721 mm
J (RF 150#, weld-neck)	14.3-in.	363 mm	22.3-in.	566 mm	30.7-in.	780 mm
J (RF 300#, weld-neck)	14.5-in.	368 mm	22.6-in.	574 mm	31.0-in.	787 mm
J (RF 600#, weld-neck)	14.8-in.	376 mm	22.9-in.	582 mm	31.3-in.	795 mm
K ((RF slip-on, RTJ slip-on, RF-DIN slip-on) ⁽¹⁾	5.7-in.	145 mm	8.7-in.	221 mm	11.9-in.	302 mm
K (RF 150#, weld-neck)	7.5-in.	191 mm	10.9-in.	277 mm	14.2-in.	361 mm
K (RF 300#, weld-neck)	7.7-in.	196 mm	11.1-in.	282 mm	14.5-in.	368 mm
K (RF 600#, weld-neck)	8.0-in.	203 mm	11.4-in.	290 mm	14.8-in.	376 mm
B.D. ⁽²⁾	0.664-in.	16.86 mm	1.097-in.	27.86 mm	1.567-in.	39.80 mm
RTDL	3.11-in.	78.9 mm	5.25-in.	133.4 mm	7.50-in.	190.5 mm
R	7.4-in.	187.96 mm	7.8-in.	198.12 mm	8.4-in.	213.36 mm

(1) Downstream length shown here includes plate thickness of 0.162-in. (4.11 mm).

(2) B.D is diameter of the precision bored portion of the upstream and downstream piping.

Rosemount 3095MFP Mass Proplate Flowmeter Ordering Information

Model	Product Description
3095MFP	Mass Proplate Flowmeter
Code	Body Material
S	316 SST
H	Hastelloy C-276
Code	Line Size
005	1/2-in. (15 mm)
010	1-in. (25 mm)
015	1 1/2-in. (40 mm)
Code	Process Connection
T1	NPT Female Body (not available with remote thermowell and RTD, requires Temperature Sensor code N)
S1 ⁽¹⁾	Socket Weld Body (not available with remote thermowell and RTD, requires Temperature Sensor code N)
P1	Pipe Ends: NPT threaded
P2	Pipe Ends: Beveled
A1	Pipe Ends: Flanged, RF, ANSI Class 150, slip-on
A3	Pipe Ends: Flanged, RF, ANSI Class 300, slip-on
A6	Pipe Ends: Flanged, RF, ANSI Class 600, slip-on
D1	Pipe Ends: Flanged, RF, DIN PN16, slip-on
D2	Pipe Ends: Flanged, RF, DIN PN40, slip-on
D3	Pipe Ends: Flanged, RF, DIN PN100, slip-on
W1	Pipe Ends: Flanged, RF, ANSI Class 150, weld-neck
W3	Pipe Ends: Flanged, RF, ANSI Class 300, weld-neck
W6	Pipe Ends: Flanged, RF, ANSI Class 600, weld-neck
R1	Pipe Ends: Flanged, RTJ, ANSI Class 150, slip-on
R3	Pipe Ends: Flanged, RTJ, ANSI Class 300, slip-on
R6	Pipe Ends: Flanged, RTJ, ANSI Class 600, slip-on
P9	Special process connections
Code	Orifice Plate Material
S	316 SST
H	Hastelloy C-276
M	Monel
Code	Bore Size Option
0010	0.010-in. (0.25 mm) for 1/2-in. pipe
0014	0.014-in. (0.36 mm) for 1/2-in. pipe
0020	0.020-in. (0.51 mm) for 1/2-in. pipe
0034	0.034-in. (0.86 mm) for 1/2-in. pipe
0066	0.066-in. (1.68 mm) for 1/2-in. pipe
0109	0.109-in. (2.77 mm) for 1/2-in. pipe
0160 ⁽²⁾	0.160-in. (4.06 mm) for 1/2-in. pipe
0196 ⁽²⁾	0.196-in. (4.98 mm) for 1/2-in. pipe
0260 ⁽²⁾	0.260-in. (6.60 mm) for 1/2-in. pipe
0340 ⁽²⁾	0.340-in. (8.64 mm) for 1/2-in. pipe
0150	0.150-in. (3.81 mm) for 1-in. pipe
0250 ⁽²⁾	0.250-in. (6.35 mm) for 1-in. pipe
0345 ⁽²⁾	0.345-in. (8.76 mm) for 1-in. pipe
0500 ⁽²⁾	0.500-in. (12.70 mm) for 1-in. pipe
0630 ⁽²⁾	0.630-in. (16.00 mm) for 1-in. pipe
0800	0.800-in. (20.32 mm) for 1-in. pipe
0295	0.295-in. (7.49 mm) for 1 1/2-in. pipe
0376 ⁽²⁾	0.376-in. (9.55 mm) for 1 1/2-in. pipe
0512 ⁽²⁾	0.512-in. (13.00 mm) for 1 1/2-in. pipe
0748 ⁽²⁾	0.748-in. (19.00 mm) for 1 1/2-in. pipe
1022	1.022-in. (25.96 mm) for 1 1/2-in. pipe
1184	1.184-in. (30.07 mm) for 1 1/2-in. pipe

Rosemount Integral Orifice Flowmeter Series

Product Data Sheet
00813-0100-4686, Rev NA
March 2008

Rosemount 3095MFP Mass Proplate Flowmeter Ordering Information

Code	Transmitter Connection Platform	
D3	Direct-mount, 3-valve manifold, SST	
D4	Direct-mount, 3-valve manifold, <i>Hastelloy-C</i>	
D5	Direct-mount, 5-valve manifold, SST	
D6	Direct-mount, 5-valve manifold, <i>Hastelloy-C</i>	
D7	Direct-mount, High Temperature, 5-valve manifold, SST	
R3	Remote-mount, 3-valve manifold, SST	
R4	Remote-mount, 3-valve manifold, <i>Hastelloy-C</i>	
R5	Remote-mount, 5-valve manifold, SST	
R6	Remote-mount, 5-valve manifold, <i>Hastelloy-C</i>	
Code	Differential Pressure Range	
1	0 to 25 in H ₂ O (0 to 62.2 mbar)	
2	0 to 250 in H ₂ O (0 to 623 mbar)	
3	0 to 1000 in H ₂ O (0 to 2.5 bar)	
Code	Static Pressure Range	
B	0 – 8 to 0 – 800 psia (0 –55.16 to 0 – 5515.8 kPa)	
C	0 – 8 to 0 – 800 psig (0 –55.16 to 0 – 5515.8 kPa)	
D	0 – 36.2 to 0 – 3626 psia (0 –250 to 0 – 25000 kPa)	
E	0 – 36.2 to 0 – 3626 psig (0 –250 to 0 – 25000 kPa)	
Code	Output Protocol	
A	4–20 mA with digital signal based on <i>HART</i> protocol	
V	FOUNDATION fieldbus protocol	
Code	Transmitter Housing Material	Conduit Entry Size
1A	Polyurethane-covered aluminum	¹ / ₂ -14 NPT
1B	Polyurethane-covered aluminum	M20 x 1.5 (CM20)
1C	Polyurethane-covered aluminum	G ¹ / ₂
1J	SST	¹ / ₂ -14 NPT
1K	SST	M20 x 1.5 (CM20)
1L	SST	G ¹ / ₂
Code	Options	
Performance Class		
U3 ⁽³⁾	Ultra for Flow: up to ±0.95% mass flow rate accuracy, up to 10:1 turndown, 10-year stability, limited 12-year warranty	
PlantWeb Control Functionality		
A01 ⁽⁴⁾	Advanced Control Function Block Suite	
High Temperature Materials		
G	High temperature Option (850 °F (454 °C))	
Temperature Sensor⁽⁵⁾		
N	No thermowell, cable and RTD (fixed temperature mode)	
Optional Connection		
G1	DIN 19231 Transmitter Connection	
Pressure Testing		
P1 ⁽⁶⁾	Hydrostatic Testing	
Special Cleaning		
P2	Cleaning for special processes	
PA	Cleaning per ASTM G93 Level D (section 11.4)	
Material Testing		
V1	Dye Penetrant Exam	
Material Examination		
V2	Radiographic Examination (available only with Process Connection codes W1, W3, and W6)	
Flow Calibration		
WD ⁽⁷⁾	Flow Rate Calibration	
WZ ⁽⁷⁾	Special Calibration	
Special Inspection		
QC1	Visual and dimensional inspection with certificate	
QC7	Inspection and performance certificate	

Rosemount 3095MFP Mass Proplate Flowmeter Ordering Information

Material Traceability Certification	
Q8 ⁽⁸⁾	Material certification per ISO 10474 3.1.B and EN 10204 3.1.B
Code Conformance	
J2 ⁽⁹⁾	ANSI / ASME B31.1
J3 ⁽⁹⁾	ANSI / ASMEB31.3
Material Conformance	
J5 ⁽¹⁰⁾	NACE MR-0175 / ISO 15156
Country Certification	
J1	Canadian Registration
J6	European Pressure Directive (PED)
Transmitter Calibration Certificate	
Q4	Calibration Data Certificate for Transmitter
Product Certifications	
E1	ATEX Flameproof
I1	ATEX Intrinsic Safety
N1	ATEX Type n
K1	ATEX Flameproof, Intrinsic Safety, Type n, Dust (combination of E1, I1, N1, and ND)
ND	ATEX Dust
E5	FM Explosion-proof, Dust Ignition-proof
I5	FM Intrinsically Safe, Division 2
K5	FM Explosion-proof, Dust Ignition-proof, Intrinsically Safe, Division 2 (combination of E5 and I5)
E6	CSA Explosion-proof, Dust Ignition-proof, Division 2
I6	CSA Intrinsically Safe, Division 2
K6	CSA Explosion-proof, Intrinsically Safe, Division 2 (combination of E6 and I6)
IE ⁽¹¹⁾	FM FISCO Intrinsically Safe; for FOUNDATION fieldbus protocol only
IF ⁽¹¹⁾	CSA FISCO Intrinsically Safe; for FOUNDATION fieldbus protocol only
IA ⁽¹¹⁾	ATEX FISCO Intrinsically Safe; for FOUNDATION fieldbus protocol only
IG ⁽¹¹⁾	IECEx FISCO Intrinsic Safety
I7	IECEx Intrinsic Safety
E4	TIIS Flameproof
ID	TIIS FISCO Intrinsically Safe; for FOUNDATION fieldbus protocol only
I3	China Intrinsic Safety
E3	China Flameproof
Alternative Transmitter Material of Construction	
L1	Inert Sensor Fill Fluid (not available with Static Pressure range codes B and D)
Display	
M5	Integral mount LCD display
Terminal Blocks	
T1	Transient Protection
Typical Model Number: 3095MFP S 010 A3 S 0150 D3 1 C A 1A	

- (1) To improve pipe perpendicularity for gasket sealing, socket diameter is smaller than standard pipe O.D.
- (2) Best flow coefficient uncertainty is between $(0.2 < \beta < 0.6)$.
- (3) Ultra for Flow applicable for HART protocol, DP ranges 2 and 3 with SST isolator material and silicone fill fluid options only.
- (4) Function Blocks include: Arithmetic, Integrator, Analog Output, Signal Characterizer, Control Selector, and Output Selector.
- (5) Rosemount 3095MFP is supplied with an integral temperature sensor as standard. Thermowell material is the same as the body material.
- (6) Does not apply to Process Connection codes T1 and S1.
- (7) Not available for bore sizes 0010, 0014, 0020, or 0034.
- (8) Includes certificates for mechanical and chemical properties of bodies, orifice plates, pipes, flanges, and adapters as applicable.
- (9) Not available with DIN Process Connection codes D1, D2, or D3.
- (10) Materials of Construction comply with metallurgical requirements within NACE MR0175/ISO 15156 for sour oil field production environments. Environmental limits apply to certain materials. Consult latest standard for details. Selected materials also conform to NACE MR0103 for sour refining environments.
- (11) Consult factory for availability.

Rosemount 1195 Integral Orifice Primary Element

SPECIFICATIONS

Performance

Discharge Coefficient Uncertainty⁽¹⁾

Beta (β) ⁽²⁾	Discharge Coefficient Uncertainty
$\beta < 0.1$	$\pm 2.50\%$
$0.1 < \beta < 0.2$	$\pm 1.25\%$
$0.2 < \beta < 0.6$	$\pm 0.75\%$
$0.6 < \beta < 0.8$	$\pm 1.50\%$

(1) Without associated straight run piping, discharge coefficient uncertainty can add up to 1.5% - 5% additional error. Consult the factory for additional information.

(2) $\beta = \frac{\text{Orifice Plate Bore}}{\text{body I.D.}}$

Line Sizes

- 1/2-in. (15 mm)
- 1-in. (25 mm)
- 1 1/2-in. (40 mm)

Sizing

Contact a Emerson Process Management sales representative for assistance. A "Configuration Data Sheet" is required prior to order for application verification.

Functional

Service

- Liquid
- Gas
- Vapor

Process Temperature Limits

Standard (direct/remote mount):

- -40 to 450 °F (-40 to 232 °C)

Extended (remote mount only with option code T):

- -148 to 850 °F (-100 to 454 °C)

Maximum Working Pressure

- Pressure retention per ANSI B16.5 600# or DIN PN100

TABLE 9. 1195 Pressure Limits

Line Size	Process Connection Code	Maximum Working Pressure @ 100 °F ⁽¹⁾⁽²⁾
1/2-in. (12.7 mm)	S1 or P2 T1 or P1	3000 psig (207 bar) 1500 psig (103 bar)
1-in. (25.4 mm)	S1 or P2 T1 or P1	2000 psig (138 bar) 1500 psig (103 bar)
1 1/2-in. (38.1 mm)	S1 or P2 T1 or P1	1500 psig (103 bar) 1500 psig (103 bar)
All	Flanged	Meets flange primary pressure rating per ANSI B16.5 (EN-1092-1 for DIN flanges)

(1) For pressure ratings at temperatures less than -20 °F (-29 °C) or above 100 °F (38 °C) consult an Emerson Process Management representative.

(2) Transmitter static pressure range may limit maximum working pressure. Refer to Static Pressure Ranges specification.

Assembly to a transmitter

Select option code D11 for the Rosemount 3051S transmitter (or option code S3 for the Rosemount 3051C or 3095MV transmitters) to factory assemble the Rosemount 1195 to a Rosemount pressure transmitter. The D11 (or S3) option will drive square-root mode operation (output proportional to flow rate.) If the 1195 and transmitter are not factory assembled, they may be shipped separately. Option code S4 is required on the 1195 if assembly to a transmitter is required. For a consolidated shipment, inform an Emerson Process Management sales representative when placing the order.

Installation Consideration

Pipe Orientation

Orientation/ Flow Direction	Process ⁽¹⁾		
	Gas	Liquid	Steam
Horizontal	D/R	D/R	D/R
Vertical Up	R	D/R	R
Vertical Down	D/R	NR	NR

(1) *D = Direct mount acceptable (recommended)*
R = Remote mount acceptable
NR = Not recommended

Primary Orientation

Gas (Horizontal)

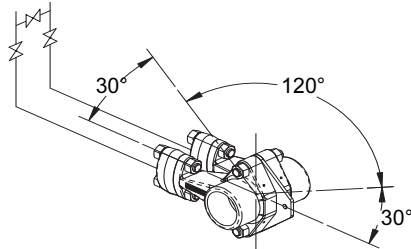

Liquid and Steam (Horizontal)

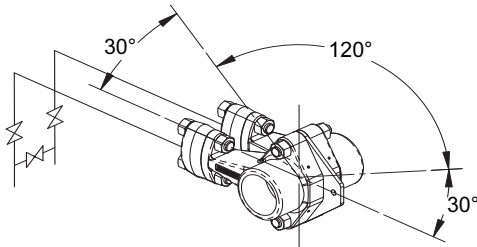

Gas (Vertical)

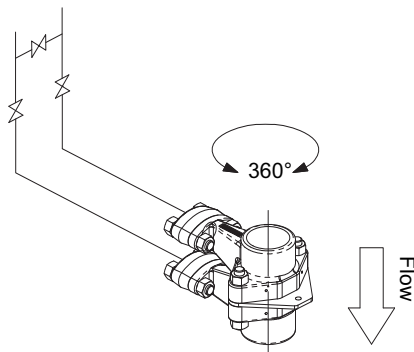

Liquid (Vertical)

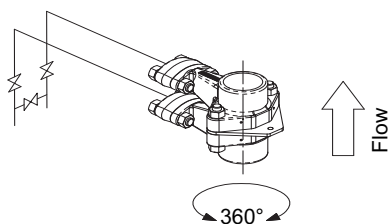

Physical

Material of Construction

Orifice Plate

- 316/316L SST
- *Hastelloy C-276*
- *Monel 400*

Body

- 316 SST (CF8M), material per ASTM A351
- *Hastelloy C-276 (CW12MW)*, material per ASTM A494

Pipe Material (If Applicable)

- A312 Gr 316/316L, B622 UNS N10276, *Hastelloy C-276*

Flange

- A182 Gr 316/316L, SB-564 UNS N10276, *Hastelloy C-276*
- Flange pressure limits are per ANSI B16.5
- Flange face finish per ANSI B16.5, 125 to 250 RMS

Body Bolts/Studs

- ASTM A193 Gr B8M studs
- ASTM A193 Gr B8M Class 2 body studs provided for high temperature option code G

Transmitter Connection Studs

- ASTM A193 Gr B8M studs

Gaskets/O-rings

- Glass filled PTFE
- *Inconel® X-750* provided for high temperature option code G
- Gaskets and o-rings must be replaced each time the 3051SFP is disassembled for installation or maintenance.

Orifice Type

Square edge-orifice bore sizes

- 0.066-in. and larger

Quadrant edge-orifice bore sizes (for 1/2-in. line size only)

- 0.034-in.
- 0.020-in.
- 0.014-in.
- 0.010-in.

NOTE

Integral orifice bodies contain corner tapped pressure ports.

Rosemount Integral Orifice Flowmeter Series

Product Data Sheet
00813-0100-4686, Rev NA
March 2008

Pipe Lengths

Upstream and downstream associated piping sections are available on the 1195. The table below lists the standard overall length (lay length) as a function of end connections and line size.

Flanged Process Connection ⁽¹⁾ (2) (3)	Line Size		
	1/2-in. (15 mm)	1-in. (25 mm)	1 1/2-in. (40 mm)
RF, ANSI Class 150, slip-on	18.2 (463)	28.9 (734)	40.3 (1023)
RF, ANSI Class 300, slip-on	18.2 (463)	28.9 (734)	40.3 (1023)
RF, ANSI Class 600, slip-on	18.2 (463)	28.9 (734)	40.3 (1023)
RF, DIN PN16, slip-on	18.2 (463)	28.9 (734)	40.3 (1023)
RF, DIN PN40, slip-on	18.2 (463)	28.9 (734)	40.3 (1023)
RF, DIN PN100, slip-on	18.2 (463)	28.9 (734)	40.3 (1023)
RF, ANSI Class 150, weld-neck	21.8 (554)	33.2 (843)	44.9 (1140)
RF, ANSI Class 300, weld-neck	22.2 (564)	33.7 (856)	45.5 (1156)
RF, ANSI Class 600, weld-neck	22.8 (579)	34.3 (871)	46.1 (1171)
RTJ, ANSI Class 150, slip-on	18.2 (463)	28.9 (734)	40.3 (1023)
RTJ, ANSI Class 300, slip-on	18.2 (463)	28.9 (734)	40.3 (1023)
RTJ, ANSI Class 600, slip-on	18.2 (463)	28.9 (734)	40.3 (1023)
NPT / Beveled Process Connection ⁽¹⁾ (2)(3)	18 (457)	28.9 (734)	40.3 (1023)

(1) See the ordering information for model code description.

(2) Consult factory for other lengths.

(3) See page 37 for additional information on associated pipe lengths.

Transmitter Connections

2 1/8-in. (54 mm) center-to-center. Other transmitter spacing can be accommodated using the optional remote adapters and customer-supplied impulse piping. DIN 19213 connections are available.

Torque Values of Standard Bolts

Orifice Body Studs (for body bolt/stud material codes C or D)

- 60 ft-lb (81 N-m)

Orifice Body Bolts (for body bolt/stud material code G)

- 78 ft-lb (105 N-m)

Transmitter studs

- 34-38 ft-lb (46-52 N-m)

3-valve manifold bolting

- 34-38 ft-lb (46-52 N-m)

Weight

The following weights are approximate

Line Size	1195 Only		With Flanged Piping ⁽¹⁾	
	lb	kg	lb	kg
1/2-in. (15 mm)	4.0	1.8	8	3.6
1-in. (25 mm)	6.0	2.7	12	5.4
1 1/2-in. (40 mm)	8.0	3.6	25	11.3

(1) As supplied with standard lengths, ANSI Class 150 flanges.

Rosemount Integral Orifice Flowmeter Series

Product Data Sheet
00813-0100-4686, Rev NA
March 2008

Rosemount 1195 Integral Orifice Primary Element Ordering Information

Model	Product Description
1195	Integral Orifice Primary Element
Code	Body Material
S	316 SST
H	<i>Hastelloy C-276</i>
Code	Line Size
005	¹ / ₂ -in. (15 mm)
010	1-in. (25 mm)
015	¹ / ₂ -in. (40 mm)
Code	Process Connection
T1	NPT Female Body (not available with remote thermowell and RTD)
S1 ⁽¹⁾	Socket Weld Body (not available with remote thermowell and RTD)
P1	Pipe Ends: NPT threaded
P2	Pipe Ends: Beveled
A1	Pipe Ends: Flanged, RF, ANSI Class 150, slip-on
A3	Pipe Ends: Flanged, RF, ANSI Class 300, slip-on
A6	Pipe Ends: Flanged, RF, ANSI Class 600, slip-on
D1	Pipe Ends: Flanged, RF, DIN PN16, slip-on
D2	Pipe Ends: Flanged, RF, DIN PN40, slip-on
D3	Pipe Ends: Flanged, RF, DIN PN100, slip-on
W1	Pipe Ends: Flanged, RF, ANSI Class 150, weld-neck
W3	Pipe Ends: Flanged, RF, ANSI Class 300, weld-neck
W6	Pipe Ends: Flanged, RF, ANSI Class 600, weld-neck
R1	Pipe Ends: Flanged, RTJ, ANSI Class 150, slip-on
R3	Pipe Ends: Flanged, RTJ, ANSI Class 300, slip-on
R6	Pipe Ends: Flanged, RTJ, ANSI Class 600, slip-on
P9	Special process connections
Code	Orifice Plate Material
S	316 SST
H	<i>Hastelloy C-276</i>
M	<i>Monel</i>
Code	Bore Size Option
0010	0.010-in. (0.25 mm) for ¹ / ₂ -in. pipe
0014	0.014-in. (0.36 mm) for ¹ / ₂ -in. pipe
0020	0.020-in. (0.51 mm) for ¹ / ₂ -in. pipe
0034	0.034-in. (0.86 mm) for ¹ / ₂ -in. pipe
0066	0.066-in. (1.68 mm) for ¹ / ₂ -in. pipe
0109	0.109-in. (2.77 mm) for ¹ / ₂ -in. pipe
0160 ⁽²⁾	0.160-in. (4.06 mm) for ¹ / ₂ -in. pipe
0196 ⁽²⁾	0.196-in. (4.98 mm) for ¹ / ₂ -in. pipe
0260 ⁽²⁾	0.260-in. (6.60 mm) for ¹ / ₂ -in. pipe
0340 ⁽²⁾	0.340-in. (8.64 mm) for ¹ / ₂ -in. pipe
0150	0.150-in. (3.81 mm) for 1-in. pipe
0250 ⁽²⁾	0.250-in. (6.35 mm) for 1-in. pipe

Rosemount 1195 Integral Orifice Primary Element Ordering Information

0345 ⁽²⁾	0.345-in. (8.76 mm) for 1-in. pipe
0500 ⁽²⁾	0.500-in. (12.70 mm) for 1-in. pipe
0630 ⁽²⁾	0.630-in. (16.00 mm) for 1-in. pipe
0800	0.800-in. (20.32 mm) for 1-in. pipe
0295	0.295-in. (7.49 mm) for 1 ¹ / ₂ -in. pipe
0376 ⁽²⁾	0.376-in. (9.55 mm) for 1 ¹ / ₂ -in. pipe
0512 ⁽²⁾	0.512-in. (13.00 mm) for 1 ¹ / ₂ -in. pipe
0748 ⁽²⁾	0.748-in. (19.00 mm) for 1 ¹ / ₂ -in. pipe
1022	1.022-in. (25.96 mm) for 1 ¹ / ₂ -in. pipe
1184	1.184-in. (30.07 mm) for 1 ¹ / ₂ -in. pipe
Code Transmitter / Body Bolt Material	
C	316 SST transmitter studs
G ⁽³⁾	High temperature (850 °F (454 °C)) (SAE J429 Gr8 / Body bolts with A193 Gr B8M transmitter studs)
Code Options	
Temperature Sensor	
S ⁽⁴⁾	Thermowell and RTD (SST Temperature Housing)
T ⁽⁴⁾	Thermowell and RTD (Aluminum Temperature Housing)
Assemble to Transmitter	
S4 ⁽⁵⁾	Factory assembly – attached to transmitter and manifold
Optional Bore Calculation	
BC	Bore Calculation
Optional Connection	
G1	DIN 19231 Transmitter Connection
Adapters for Remote Mounting	
G2	¹ / ₂ -14 NPT Remote Adapters – SST
G3	¹ / ₂ -14 NPT Remote Adapters – <i>Hastelloy C</i>
Pressure Testing	
P1 ⁽⁶⁾	Hydrostatic Testing
Special Cleaning	
P2	Cleaning for special processes
PA	Cleaning per ASTM G93 Level D (section 11.4)
Material Testing	
V1	Dye Penetrant Exam
Material Examination	
V2	Radiographic Examination (available only with Process Connection code W1, W3, and W6)

Rosemount Integral Orifice Flowmeter Series

Product Data Sheet
00813-0100-4686, Rev NA
March 2008

Rosemount 1195 Integral Orifice Primary Element Ordering Information

Flow Calibration

WD ⁽⁷⁾	Discharge coefficient Verification
WZ ⁽⁷⁾	Special Calibration

Special Inspection

QC1	Visual and dimensional inspection with certificate
QC7	Inspection and performance certificate

Material Traceability Certification

Q8 ⁽⁸⁾	Material certification per ISO 10474 3.1.B and EN 10204 3.1.B
-------------------	---

Code Conformance

J2 ⁽⁹⁾	ANSI B31.1
J3 ⁽⁹⁾	ANSI B31.3

Materials Conformance

J5 ⁽¹⁰⁾	NACE MR-0175 / ISO 15156
--------------------	--------------------------

Country Certification

J1	Canadian Registration
J6	European Pressure Directive (PED)

Special Configuration (Hardware)

A1	External Ground Screw for Temperature Connection Head
A2	Cover Clamp and External Ground Screw for Temperature Connection Head

Typical Model Number: 1195 S 010 A3 S 0150 C

- (1) To improve pipe perpendicularity for gasket sealing, socket diameter is smaller than standard pipe O.D.
- (2) Best flow coefficient uncertainty is between $(0.2 < \beta < 0.6)$.
- (3) Not available with Assemble to Transmitter code S4 or Temperature Sensor code S or T with E5.
- (4) Thermowell material is the same as the body material.
- (5) Not available with Process Connection code S1.
- (6) Does not apply to Process Connection codes T1 and S1.
- (7) Not available for bore sizes 0010, 0014, 0020, or 0034.
- (8) Includes certificates for mechanical and chemical properties of bodies, orifice plates, pipes, flanges, and adapters as applicable.
- (9) Not available with DIN Process Connection codes D1, D2, or D3.
- (10) Materials of Construction comply with metallurgical requirements within NACE MR0175/ISO 15156 for sour oil field production environments. Environmental limits apply to certain materials. Consult latest standard for details. Selected materials also conform to NACE MR0103 for sour refining environments.

DIMENSIONAL DRAWINGS

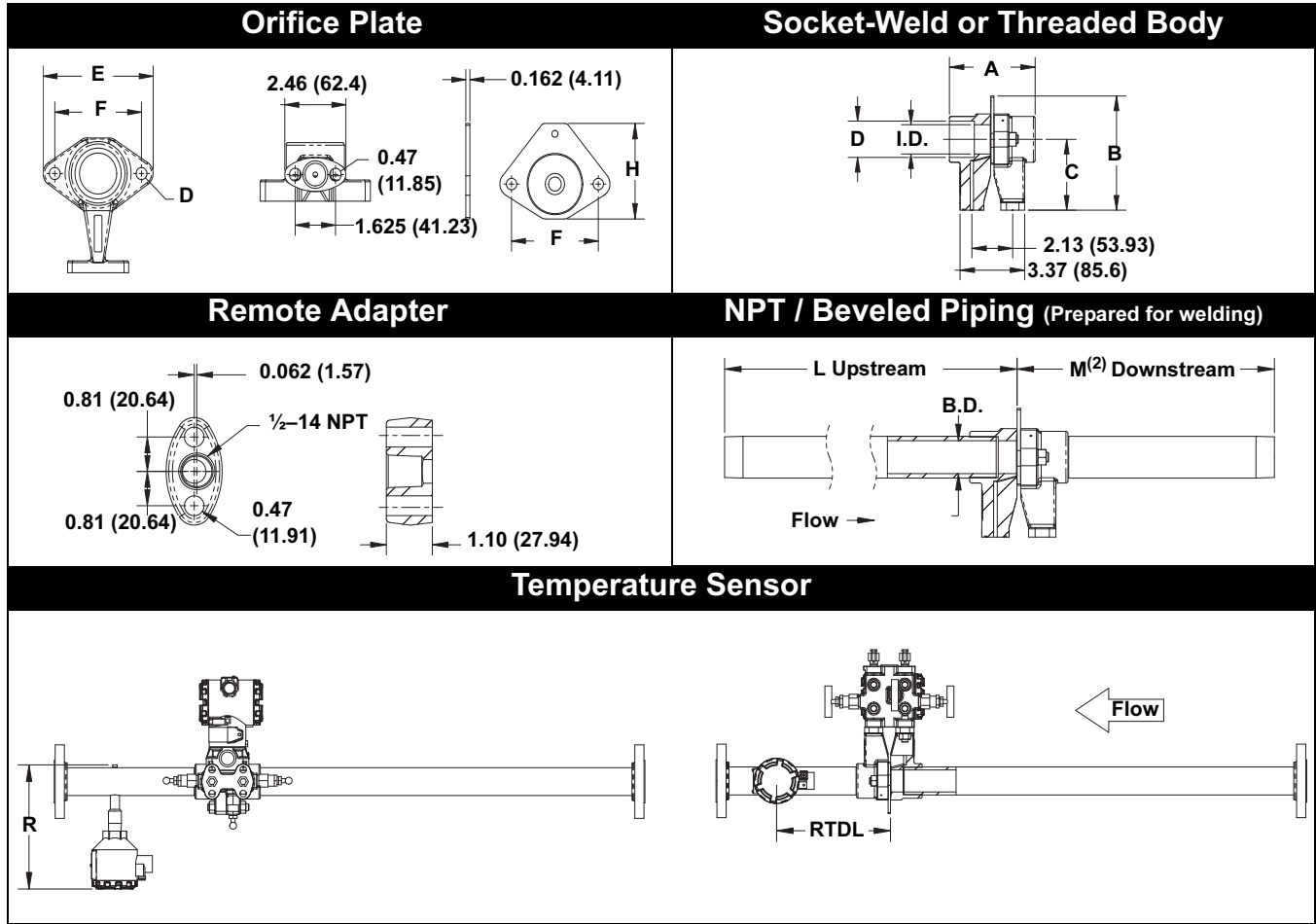

Dimension	Line Size					
	1/2-in. (12.7 mm)		1-in. (25.4 mm)		1 1/2-in. (38.1 mm)	
A	3.4-in.	86 mm	3.8-in.	97 mm	4.5-in.	114 mm
B	4.7-in.	119.4 mm	5.2-in.	132 mm	5.9-in.	149.9 mm
C	3.0-in.	76 mm	3.3-in.	84 mm	3.7-in.	94 mm
D ⁽¹⁾	0.805-in.	20.45 mm	1.280-in.	32.51 mm	1.865-in.	47.37 mm
E	3.6-in.	91 mm	3.9-in.	99 mm	4.4-in.	112 mm
F	2.6-in.	66 mm	3.0-in.	76 mm	3.5-in.	89 mm
H	2.5-in.	64 mm	3.0-in.	76 mm	3.5-in.	89 mm
L	12.4-in.	315 mm	20.1-in.	511 mm	28.2-in.	716 mm
M	5.6-in.	142 mm	8.6-in.	218 mm	11.7-in.	297 mm
B.D. ⁽²⁾	0.664-in.	16.87 mm	1.097-in.	27.86 mm	1.567-in.	39.80 mm
I.D.	0.622-in.	15.80 mm	1.049-in.	26.64 mm	1.500-in.	38.10 mm

(1) To improve pipe perpendicularity for gasket sealing, socket diameter "D" is smaller than standard pipe O.D. Pipe O.D. must be machined smaller than socket diameter "D" to ensure proper fit.

(2) B.D. is diameter of the precision bored portion of the upstream and downstream piping.

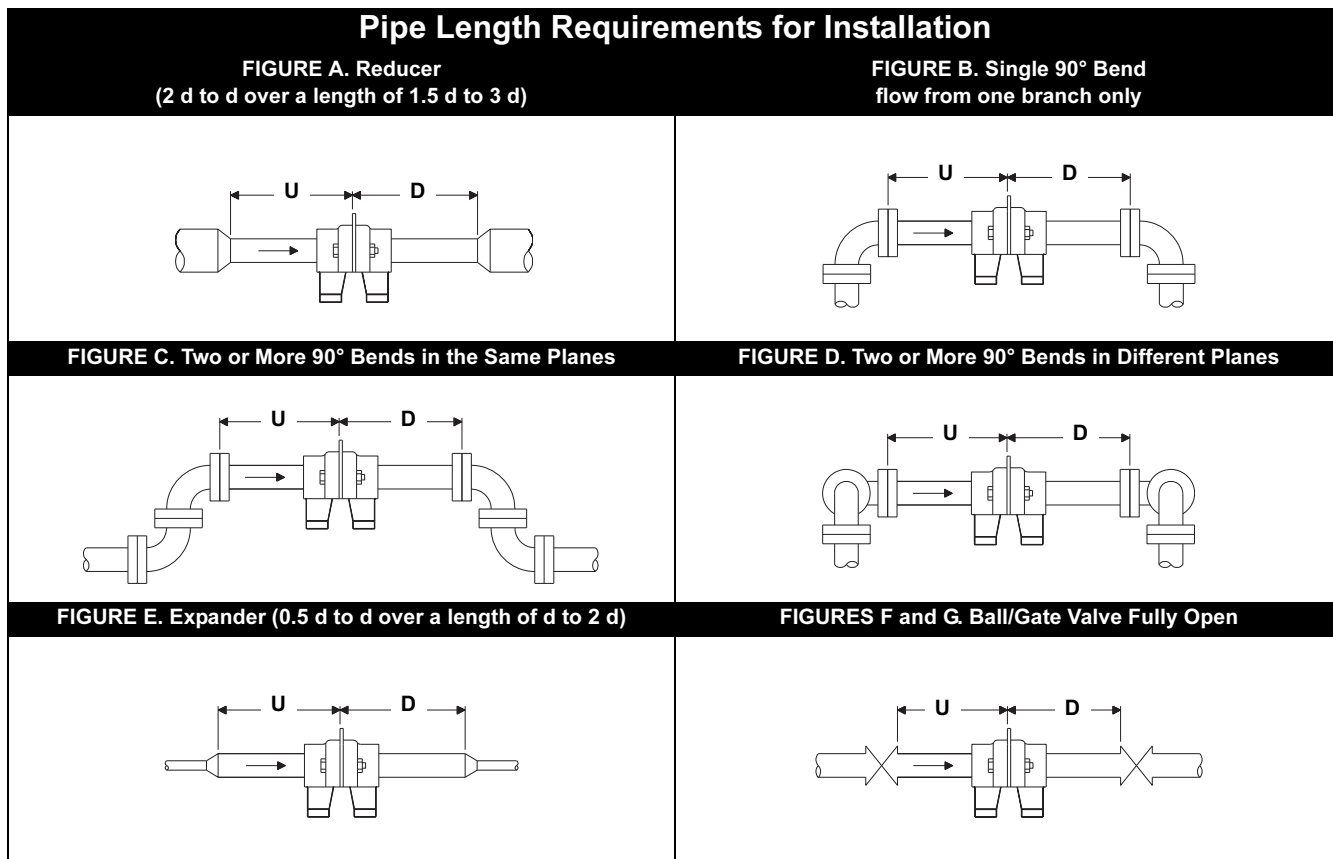

TABLE 10. Recommended lengths of pipe

The following *chart* gives the upstream (U) and downstream (D) lengths as a guideline recommended by ISO 5167 for the above installations. The lengths are given in terms of pipe diameters. For example, for a 1-in. line size with a beta ratio (b) of 0.4 using installation type B above, the straight length of upstream piping required is $16 \times 1 = 16$ in., and downstream $6 \times 1 = 6$ in.

β	On Upstream (U)						On Downstream (D) FIGURES A - G
	FIGURE A ⁽¹⁾	FIGURE B ⁽¹⁾	FIGURE C ⁽¹⁾	FIGURE D ⁽¹⁾	FIGURE E ⁽¹⁾	FIGURE F and G ⁽¹⁾	
<0.20	5 ⁽²⁾	6 (3)	10 ⁽²⁾	34 (17)	6 ⁽²⁾	12 (6)	4 (2)
0.40	5 ⁽²⁾	16 (3)	10 ⁽²⁾	50 (25)	12 (8)	12 (6)	6 (3)
0.50	8 (5)	22 (9)	18 (10)	75 (34)	20 (9)	12 (6)	6 (3)
0.60	9 (5)	42 (13)	30 (18)	65 (18)	26 (11)	14 (7)	7 (3,5)
0.67	12 (6)	44 (20)	44 (18)	60 (18)	28 (14)	18 (9)	7 (3,5)
0.75	13 (8)	44 (20)	44 (18)	75 (18)	36 (18)	24 (12)	8 (4)
	U						D

(1) Values in parenthesis correspond to an additional +0.5% discharge coefficient uncertainty.

(2) Straight length gives zero additional uncertainty; data not available for shorter lengths.

HART Configuration Data Sheet (CDS)

DP FLOW CDS

Complete this form to define a custom flow configuration for DP Flowmeters. Unless specified, the flowmeter will be shipped with the default values identified by the H symbol.

For technical assistance in filling out this CDS, call a Rosemount representative.

NOTE

Any missing information will be processed with the indicated default values.

* = Required Item

★ = Default

Customer Information

Customer: _____ Contact Name: _____
Customer Phone: _____ Customer Fax: _____
Customer Approval Sign-Off: _____ Customer PO: _____

Calculation Approval

Check this box if a calculation for approval prior to manufacturing is required

Application and Configuration Data Sheet (Required with Order)

Tag: _____

Model No ⁽¹⁾ _____

* Select fluid type Liquid Gas Steam

* Fluid name⁽²⁾ _____

Flowmeter Information (optional)

* Failure Mode Alarm Direction (select one) Alarm High★ Alarm Low

Software Tag: _____ (8 characters)

Descriptor: _____ (16 characters)

Message: _____
_____ (32 characters)

Date: Day ___ (numeric) Month ___ (numeric) Year ___ (numeric)

(1) A complete model number is required before Rosemount Inc. can process the order.

(2) If the Fluid is not located in Table 11 on page Flow-41, the "Fluid Data Sheet (FDS)" on page 45 must be completed.

For Rosemount Use Only

S.O.: _____ LI
CHAMP: _____ DATE: _____
ADMIN: _____

Rosemount Integral Orifice Flowmeter Series

Product Data Sheet
00813-0100-4686, Rev NA
March 2008

* = Required Item
★ = Default

Primary Element Information

* Select Differential Producer (Select One)

Annubar

- 485 Annubar/ 3095MFA Mass ProBar, 3051SFA ProBar
- 285 Annubar
- Annubar Diamond II + / Mass Probar
- Long Radius Wall Taps, ASME
- Long Radius Wall Taps, ISO
- ISA 1932, ISO

Venturi

- Nozzle, ISO
- Rough Cast/Fabricated Inlet, ASME
- Round Cast Inlet, ISO
- Machined Inlet, ASME
- Machined Inlet, ISO
- Welded Inlet, ISO

Other (All options require a discharge coefficient value)

- Calibrated Orifice: Flange, Corner, or D & D/2 Taps.

Discharge coefficient: _____

- Calibrated Orifice: 2¹/₂ D & 8D Taps

Discharge coefficient: _____

- Calibrating Nozzle

Discharge coefficient: _____

- Calibrating Venturi

Discharge coefficient: _____

- Area Averaging Meter

Discharge coefficient: _____

- V-Cone®

Discharge coefficient: _____

Diameter (d) _____

Orifice

- 3051SFP, 3095MFP, 1195
- 405C, 405P, 3051SFC, 3095MFC
- 1595 Conditioning Orifice
- 2¹/₂D & 8D Taps, ASME
- Corner Taps, ASME
- Corner Taps, ISO
- D & D/2 Taps, ASME
- D & D/2 Taps, ISO
- D & D/2 Taps, ISO 99 Amendment 1
- Flange Taps, AGA
- Flange Taps, ASME
- Flange Taps, ISO
- Flange Taps, ISO 99 Amendment 1
- Small Bore, Flange Taps, ASME

inch★

millimeters

at _____

°F

°C

68 °F★

ODF _____

ODT _____

Special Annubar dimension (required if customer supplies mounting hardware).

Pipe Information

* Orientation / Flow Direction: Vertical Up Vertical Down Horizontal

* Line Size / Schedule: _____ Body I.D. (D): _____

Materials of Construction

* Pipe Material Carbon Steel 304 SST 316 SST Hastelloy Other _____

* Primary Element Material 316 SST Hastelloy Other _____ (Please verify material availability)

Operating Conditions

	4 mA value	Minimum	Normal	Maximum	Full Scale: 20 mA flow rate (design to P and T)	Design
Flow Rate	0	*(1)	*	*		
Pressure (P)	—	*(1)	*	*(1)	*(2)	
Temperature (T)	—	*(1)	*	*(1)	*	

RTD Mode

Normal Mode ★ (Requires a RTD to be connected. If the RTD is disconnected or fails, the 3095MV output goes to alarm value)

Fixed Temperature Mode: Specify the fixed temperature value _____ °F °C

Backup Mode (Uses the connected RTD for temperature measurement. If the RTD is disconnected or fails, the transmitter uses a fixed temperature value as a backup. This will not cause the mA output to go to alarm value and can potentially cause inaccurate flow measurement.) Fixed temperature value to be used as backup _____ °F °C

* = Required Item

★ = Default

Base Conditions

- Standard Base (P=14.696 psia / 101.325 kPa abs, T= 60 °F (15.56 °C))
- Normal Base (P=14.696 psia / 101.325 kPa abs, T= 32 °F (0 °C))
- Standard Base for Natural Gas (AGA) (P=14.73 psia, T= 60°F (15.56 °C))
- User Defined: P= _____ Units: _____ T= _____ Units = _____
- Compressibility at Base: _____ OR Density at Base: _____

(1) Operating ranges for pressure and temperature are needed for transmitter configuration.

(2) Required to verify that the product selection meets design criteria.

TABLE 11. Rosemount Fluids Database⁽¹⁾

Acetic Acid	Divinyl Ether	Methane	n-Hexane	1-Heptanol
Acetone	Ethane	Methanol	n-Octane	1-Heptene
Acetonitrile	Ethanol	Methyl Acrylate	n-Pentane	1-Hexene
Acetylene	Ethylamine	Methyl Ethyl Ketone	Oxygen	1-Hexadecanol
Acrylonitrile	Ethylbenzene	Methyl Vinyl Ether	Pentafluorothane	1-Octanol
Air	Ethylene	m-Chloronitrobenzene	Phenol	1-Octene
Allyl Alcohol	Ethylene Glycol	Neon	Propadiene	1-Nonanol
Ammonia	Ethylene Oxide	Neopentane	Pyrene	1-Pentadecanol
Argon	Fluorene	Nitric Acid	Propylene	1-Pentanol
Benzene	Furan	Nitric Oxide	Styrene	1-Pentene
Benzaldehyde	Helium-4	Nitrobenzene	Sulfur Dioxide	1-Undecanol
Benzyl Alcohol	Hydrazine	m-Dichlorobenzene	Propane	1-Nonanal
Biphenyl	Hydrogen	Nitroethane	Toluene	1,2,4- Trichlorobenzene
Carbon Dioxide	Hydrogen Chloride	Nitrogen	Trichloroethylene	1,1,2- Trichloroethane
Carbon Monoxide	Hydrogen Cyanide	Nitromethane	Vinyl Acetate	1,1,2,2- Tetrafluoroethane
Carbon Tetrachloride	Hydrogen Peroxide	Nitrous Oxide	Vinyl Chloride	1,2-Butadiene
Chlorine	Hydrogen Sulfide	n-Butane	Vinyl Cyclohexane	1,3-Butadiene
Chlorotrifluoroethylene	Isobutane	n-Butanol	Water	1,3,5- Trichlorobenzene
Chloroprene	Isobutene	n-Butyraldehyde	1-Butene	1,4-Dioxane
Cycloheptane	Isobutyl benzene	n-Butyronitrile	1-Decene	1,4-Hexadiene
Cyclohexane	Isopentane	n-Decane	1-Decanal	2-Methyl-1-Pentene
Cyclopentane	Isoprene	n-Dodecane	1-Decanol	2,2-Dimethylbutane
Cyclopentene	Isopropanol	n-Heptadecane	1-Dodecene	
Cyclopropane		n-Heptane	1-Dodecanol	

(1) This list is subject to change without notice. Steam per ASME Steam tables. All other fluids per AIChE.

Drawing/Notes

FOUNDATION fieldbus™ Configuration Data Sheet (CDS)

DP FLOW CDS

Complete this form to define a custom flow configuration for DP Flowmeters. Unless specified, the flowmeter will be shipped with the default values identified by the H symbol.

For technical assistance in filling out this CDS, call a Rosemount representative.

NOTE

Any missing information will be processed with the indicated default values.

* = Required Item

★ = Default

Customer Information

Customer:	Contact Name:
Customer Phone:	Customer Fax:
Customer Approval Sign-Off:	Customer PO:

Calculation Approval

Check this box if a calculation for approval prior to manufacturing is required

Application and Configuration Data Sheet (Required with Order)

Tag:

Model No ⁽¹⁾

* **Select fluid type** Liquid Gas Steam

* **Fluid name⁽²⁾**

Flowmeter Information (optional)

* Failure Mode Alarm Direction (select one) Alarm High★ Alarm Low

Software Tag: _____ (16 characters)

Descriptor: _____
 _____ (32 characters)

Message: _____
 _____ (32 characters)

Date: Day ___ (numeric) Month ___ (numeric) Year ___ (numeric)

(1) A complete model number is required before Rosemount Inc. can process the order.

(2) If the Fluid is not located in Table 12 on page Flow-44, the "Fluid Data Sheet (FDS)" on page 45 must be completed.

For Rosemount Use Only

S.O.:	LI
CHAMP:	DATE:
	ADMIN:

* = Required Item
 ★ = Default

Primary Element Information

* Select Differential Producer (Select One)

Annubar

- 485 Annubar/ 3095MFA Mass ProBar, 3051SFA ProBar
- 285 Annubar
- Annubar Diamond II + / Mass Probar
- Long Radius Wall Taps, ASME
- Long Radius Wall Taps, ISO
- ISA 1932, ISO

Venturi

- Nozzle, ISO
- Rough Cast/Fabricated Inlet, ASME
- Round Cast Inlet, ISO
- Machined Inlet, ASME
- Machined Inlet, ISO
- Welded Inlet, ISO

Other (All options require a discharge coefficient value)

- Calibrated Orifice: Flange, Corner, or D & D/2 Taps.

Discharge coefficient: _____

- Calibrated Orifice: 2¹/₂ D & 8D Taps

Discharge coefficient: _____

- Calibrating Nozzle

Discharge coefficient: _____

- Calibrating Venturi

Discharge coefficient: _____

- Area Averaging Meter

Discharge coefficient: _____

- V-Cone®

Discharge coefficient: _____

Diameter (d) _____

Orifice

- 3051SFP, 3095MFP, 1195
- 405C, 405P, 3051SFC, 3095MFC
- 1595 Conditioning Orifice
- 2¹/₂D & 8D Taps, ASME
- Corner Taps, ASME
- Corner Taps, ISO
- D & D/2 Taps, ASME
- D & D/2 Taps, ISO
- D & D/2 Taps, ISO 99 Amendment 1
- Flange Taps, AGA
- Flange Taps, ASME
- Flange Taps, ISO
- Flange Taps, ISO 99 Amendment 1
- Small Bore, Flange Taps, ASME

inch★

millimeters

at _____

°F

°C

68 °F★

ODF _____

ODT _____

Special Annubar dimension (required if customer supplies mounting hardware).

Pipe Information

* Orientation / Flow Direction: Vertical Up Vertical Down Horizontal

* Line Size / Schedule: _____ Body I.D. (D): _____

Materials of Construction

* Pipe Material Carbon Steel 304 SST 316 SST Hastelloy Other _____

* Primary Element Material 316 SST Hastelloy Other _____ (Please verify material availability)

Operating Conditions

	4 mA value	Minimum	Normal	Maximum	Full Scale:20 mA flow rate (design to P and T)	Design
Flow Rate	0	*(1)	*	*		
Pressure (P)	—	*(1)	*	*(1)	*(2)	
Temperature (T)	—	*(1)	*	*(1)	*	

RTD Mode

Normal Mode ★ (Requires a RTD to be connected. If the RTD is disconnected or fails, the 3095MV output goes to alarm value)

Fixed Temperature Mode: Specify the fixed temperature value _____ °F °C

Backup Mode (Uses the connected RTD for temperature measurement. If the RTD is disconnected or fails, the transmitter uses a fixed temperature value as a backup. This will not cause the mA output to go to alarm value and can potentially cause inaccurate flow measurement.) Fixed temperature value to be used as backup _____ °F °C

Rosemount Integral Orifice Flowmeter Series

Product Data Sheet
00813-0100-4686, Rev NA
March 2008

* = Required Item

★ = Default

Base Conditions

- Standard Base (P=14.696 psia / 101.325 kPa abs, T= 60 °F (15.56 °C))
- Normal Base (P=14.696 psia / 101.325 kPa abs, T= 32 °F (0 °C))
- Standard Base for Natural Gas (AGA) (P=14.73 psia, T= 60°F (15.56 °C))
- User Defined: P= _____ Units: _____ T= _____ Units = _____
- Compressibility at Base: _____ OR Density at Base: _____

(1) Operating ranges for pressure and temperature are needed for transmitter configuration.

(2) Required to verify that the product selection meets design criteria.

TABLE 12. Rosemount Fluids Database⁽¹⁾

Acetic Acid	Divinyl Ether	Methane	n-Hexane	1-Heptanol
Acetone	Ethane	Methanol	n-Octane	1-Heptene
Acetonitrile	Ethanol	Methyl Acrylate	n-Pentane	1-Hexene
Acetylene	Ethylamine	Methyl Ethyl Ketone	Oxygen	1-Hexadecanol
Acrylonitrile	Ethylbenzene	Methyl Vinyl Ether	Pentafluorothane	1-Octanol
Air	Ethylene	m-Chloronitrobenzene	Phenol	1-Octene
Allyl Alcohol	Ethylene	Neon	Propadiene	1-Nonanol
Ammonia	GlycolEthylene	Neopentane	Pyrene	1-Pentadecanol
Argon	Oxide	Nitric Acid	Propylene	1-Pentanol
Benzene	Fluorene	Nitric Oxide	Styrene	1-Pentene
Benzaldehyde	Furan	Nitrobenzene	Sulfur Dioxide	1-Undecanol
Benzyl Alcohol	Helium-4	m-Dichlorobenzene	Propane	1-Nonanal
Biphenyl	Hydrazine	Nitroethane	Toluene	1,2,4- Trichlorobenzene
Carbon Dioxide	Hydrogen	Nitrogen	Trichloroethylene	1,1,2- Trichloroethane
Carbon Monoxide	Hydrogen Chloride	Nitromethane	Vinyl Acetate	1,1,2,2- Tetrafluoroethane
Carbon Tetrachloride	Hydrogen Cyanide	Nitrous Oxide	Vinyl Chloride	1,2-Butadiene
Chlorine	Hydrogen Peroxide	n-Butane	Vinyl Cyclohexane	1,3-Butadiene
Chlorotrifluoroethylene	Hydrogen Sulfide	n-Butanol	Water	1,3,5- Trichlorobenzene
Chloroprene	Isobutane	n-Butyraldehyde	1-Butene	1,4-Dioxane
Cycloheptane	Isobutene	n-Butyronitrile	1-Decene	1,4-Hexadiene
Cyclohexane	Isobutyl benzene	n-Decane	1-Decanal	2-Methyl-1-Pentene
Cyclopentane	Isopentane	n-Dodecane	1-Decanol	2,2-Dimethylbutane
Cyclopentene	Isoprene	n-Heptadecane	1-Dodecene	
Cyclopropane	Isopropanol	n-Heptane	1-Dodecanol	

(1) This list is subject to change without notice. Steam per ASME Steam tables. All other fluids per AIChE.

Block Tag Names

AI Block Name (Flow): _____ (AI 1400 ★)

AI Block Name (DP): _____ (AI 1500 ★)

AI Block Name (SP): _____ (AI 1600 ★)

AI Block Name (PT): _____ (AI 1700 ★)

INTEG Block Name (Flow Total): _____ (INTEG 2100 ★)

Drawing/Notes

Fluid Data Sheet (FDS)

For custom fluid not in the Rosemount Fluid Database

For technical assistance in filling out this CDS, call an Emerson Process Management representative. Complete this form to define a custom fluid. The H symbol identifies the default value.

NOTE

This form is not required if using the Rosemount Fluid Database.

* = Required Item

★ = Default

Customer Information

Customer:	Contact Name:
Customer Phone:	Customer Fax:
	Customer PO:

Fluid Properties

<input type="checkbox"/> Custom Liquid– Complete Table	<input type="checkbox"/> Liquid
<input type="checkbox"/> Custom Gas– Complete Table	<input type="checkbox"/> Gas
<input type="checkbox"/> Custom Natural Gas– Complete Table	<input type="checkbox"/> Natural Gas

For Rosemount Use Only

S.O.:	LI
CHAMP:	DATE:
	ADMIN:

Rosemount Integral Orifice Flowmeter Series

Product Data Sheet
00813-0100-4686, Rev NA
March 2008

TABLE 13. Custom Liquid Worksheet

* = Required Item

★ = Default

Mass Liquid Density and Viscosity Information

1. Fill in the following operating temperatures

- a) _____ min
- b) _____ [$^{1/3}(\text{max} - \text{min})$] + min
- c) _____ [$^{2/3}(\text{max} - \text{min})$] + min
- d) _____ max

2. Transfer the values from the above section to the numbered lines below.

3. Check one Density box, then enter the values for each temperature and the standard density.

4. Check one Viscosity box, then enter values for each temperature. (At least one viscosity value is required).

Density

- Density in lbs/CuFt
- Density in kg/CuM

Viscosity

- Viscosity in centipoise
- Viscosity in lbs/ft sec
- Viscosity in pascal sec

Temperature

- a) _____ min
- b) _____ [$^{1/3}(\text{max} - \text{min})$] + min
- c) _____ [$^{2/3}(\text{max} - \text{min})$] + min
- d) _____ max

Temperature

- a) _____ min.
- b) _____ [$^{1/3}(\text{max} - \text{min})$] + min
- c) _____ [$^{2/3}(\text{max} - \text{min})$] + min
- d) _____ max

Base density: _____
(at base reference conditions specified)

Volumetric Liquid Density and Viscosity Information

* Density at Flow: _____ Units: lb/ft³ Kg/m³ Other:

OR

Specific Gravity at Flow: _____

* Viscosity at Flow: _____ Units: Centipoise Other:

TABLE 14. Custom Gas Worksheet

* = Required Item

★ = Default

Mass Gas Compressibility and Viscosity Information

1. Fill in the following operating pressures and operating temperatures

Operating Pressures

- 1) _____ min
- 2) _____ [$^{1/3}(\text{max} - \text{min})$] + min
- 3) _____ [$^{2/3}(\text{max} - \text{min})$] + min
- 4) _____ max

Operating Temperatures

- 5) _____ min
- 6) _____ [$^{1/2}(\text{max} - \text{min})$] + min
- 7) _____ max
- 8) _____ [$^{1/3}(\text{max} - \text{min})$] + min
- 9) _____ [$^{2/3}(\text{max} - \text{min})$] + min

2. Transfer the values from the above section to the numbered lines below

- 3. Check one Density/Compressibility box, then enter the 12 values for each pressure/temperature range.
- 4. Check one Viscosity box, then enter values for each temperature. (At least one viscosity value is required).
- 5. Enter values for molecular weight, isentropic exponent, and standard density (or standard compressibility).

Density

- Density in lbs/CuFt
- Density in kg/CuM
- Compressibility

Pressure Temperature

- | | |
|----------|----------|
| 1) _____ | 5) _____ |
| 2) _____ | 5) _____ |
| 3) _____ | 5) _____ |
| 4) _____ | 5) _____ |
| 1) _____ | 6) _____ |
| 2) _____ | 6) _____ |
| 3) _____ | 6) _____ |
| 4) _____ | 6) _____ |
| 1) _____ | 7) _____ |
| 2) _____ | 7) _____ |
| 3) _____ | 7) _____ |
| 4) _____ | 7) _____ |

Viscosity

- Viscosity in centipoise
- Viscosity in lbs/ft sec
- Viscosity in pascal sec

Temperature

- 5) _____
- 8) _____
- 9) _____
- 7) _____

Molecular Weight: _____

Isentropic Exponent: _____ 1.4 ★

Standard density/compressibility: _____

Volumetric Gas Compressibility and Viscosity Information

* Density at Flow: _____ Units: lb/ft³ Kg/m³ Other:

OR

M.W. / Specific Gravity at Flow: _____

Compressibility at Flow: _____

Compressibility at Base: _____

* Viscosity at Flow: _____ Units: Centipoise Other: Isentropic Exponent (K): _____ 1.4 ★

Rosemount Integral Orifice Flowmeter Series

Product Data Sheet
00813-0100-4686, Rev NA
March 2008

TABLE 15. Natural Gas Worksheet

NOTE

The minimum requirement for the Volumetric options is highlighted gray below.

Compressibility Factor Information

Choose desired characterization method and only enter values for that method.

Detail Characterization Method (AGA8 1992)

		Mole	Valid Range
CH ₄	Methane mole percent	%	0 – 100 percent
N ₂	Nitrogen mole percent	%	0 – 100 percent
CO ₂	Carbon Dioxide mole percent	%	0 – 100 percent
C ₂ H ₆	Ethane mole percent	%	0 – 100 percent
C ₃ H ₈	Propane mole percent	%	0 – 12 percent
H ₂ O	Water mole percent	%	0 – Dew point
H ₂ S	Hydrogen Sulfide mole percent	%	0 – 100 percent
H ₂	Hydrogen mole percent	%	0 – 100 percent
CO	Carbon monoxide mole percent	%	0 – 3.0 percent
O ₂	Oxygen mole percent	%	0 – 21 percent
C ₄ H ₁₀	i-Butane mole percent	%	0 – 6 percent ⁽¹⁾
C ₄ H ₁₀	n-Butane mole percent	%	0 – 6 percent ⁽¹⁾
C ₅ H ₁₂	i-Pentane mole percent	%	0 – 4 percent ⁽²⁾
C ₅ H ₁₂	n-Pentane mole percent	%	0 – 4 percent
C ₆ H ₁₄	n-Hexane mole percent	%	0 – Dew Point
C ₇ H ₁₈	n-Heptane mole percent	%	0 – Dew Point
C ₈ H ₁₈	n-Octane mole percent	%	0 – Dew Point
C ₉ H ₂₀	n-Nonane mole percent	%	0 – Dew Point
C ₁₀ H ₂₂	n-Decane mole percent	%	0 – Dew Point
He	Helium mole percent	%	0 – 3.0percent
Ar	Argon mole percent	%	0 – 1.0 percent

Gross Characterization Method, Option Code 1 (AGA8 Gr-Hv-CO₂)

	Mole	Valid Range
Specific Gravity at 14.73 psia and 60 °F		0.554 – 0.87
Volumetric gross heating value at base conditions	BTU/SCF	477 – 1150 BTU/SCF
Carbon Dioxide mole percent	%	0 – 30 percent
Hydrogen mole percent	%	0 – 10 percent
Carbon Monoxide mole percent	%	0 – 3.0 percent

Gross Characterization Method, Option Code 2 (AGA8 Gr-CO₂-N₂)

	Mole	Valid Range
Specific Gravity at 14.73 psia and 60 °F	%	0.554 – 0.87
Carbon Dioxide mole percent	%	0 – 30 percent
Nitrogen mole percent	%	0 – 50 percent
Hydrogen mole percent	%	0 – 10 percent
Carbon Monoxide mole percent	%	0 – 3.0 percent

(1) The summaries of i-Butane and n-Butane cannot exceed 6 percent.

(2) The summaries of i-Pentane and n-Pentane cannot exceed 4 percent.

NOTES

Rosemount Integral Orifice Flowmeter Series

Product Data Sheet
00813-0100-4686, Rev NA
March 2008

NOTES

Rosemount Integral Orifice Flowmeter Series

Product Data Sheet
00813-0100-4686, Rev NA
March 2008

Standard Terms and Conditions of Sale can be found at www.rosemount.com/terms_of_sale

The Emerson logo is a trade mark and service mark of Emerson Electric Co.

Rosemount, the Rosemount logotype, ProPlate, Mass ProPlate, and Annubar are registered trademarks of Rosemount Inc. MultiVariable (MV) and Tri-Loop are trademarks of Rosemount Inc. Pentium is a registered trademark of the Intel Corporation. Microsoft, Windows, and Windows NT are registered trademarks of the Microsoft Corporation. Hastelloy is a registered trademark of Haynes International. Monel and Inconel are registered trademarks of International Nickel Co. HART is a registered trademark of the HART Communication Foundation. All other marks are the property of their respective owners.

Emerson Process Management

Rosemount Inc.

8200 Market Boulevard
Chanhassen, MN USA 55317
T (US) (800) 999-9307
T (Intl) (952) 906-8888
F (952) 949-7001

www.rosemount.com

Emerson Process Management

Heath Place
Bognor Regis
West Sussex PO22 9SH
England
T 44 (0) 1243 863121
F 44 (0) 1243 867554

Emerson Process Management Asia

Pacific Private Limited

1 Pandan Crescent
Singapore 128461
T (65) 6777 8211
F (65) 6777 0947
Enquiries@AP.EmersonProcess.com

