

Blancett®

Flow Meters

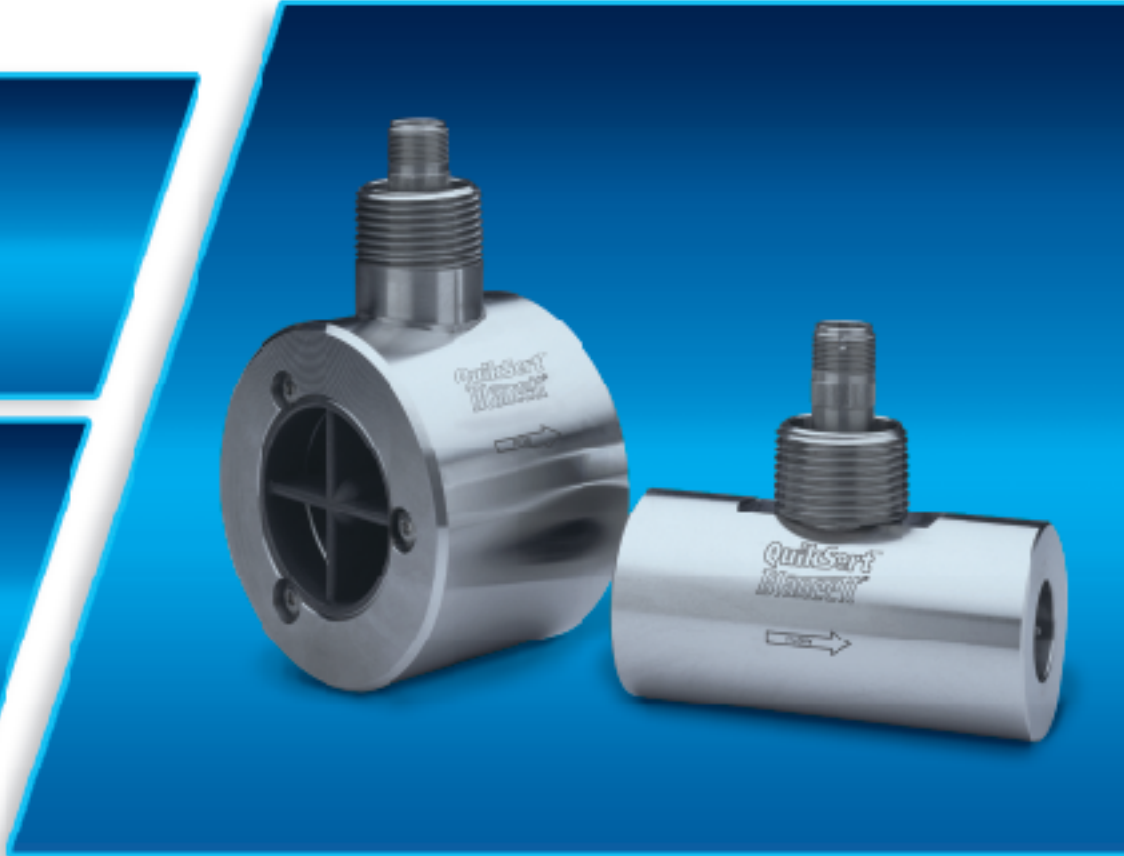

QuikSert™

Turbine Flow Meter

- Accurate ($\pm 1\%$ of reading) and reliable (repeatability $\pm 0.1\%$) flow measurement solution
- Unique “between-the-flange” design eliminates need for mating flanges
- Superior materials of construction for high performance in aggressive environments
- Wafer-style mounting configuration allowing for limited space requirements
- Modified flow straighteners for enhanced fluid dynamics

1-800-235-1638 ■ www.blancett.com

Introduction

The QuikSert in-line turbine flow meter was developed for applications where accuracy and dependability are of concern to the operator. QuikSert's stainless steel body incorporates a helical turbine with tungsten carbide shaft and bearing. It provides an efficient, long service life and a cost-effective solution for your measurement requirements.

Simple in design and construction, QuikSert utilizes modified upstream and downstream flow straighteners for a high degree of flow accuracy. Its between-the-flange design eliminates the need for mating flanges, requiring less space in the flow line, lowering costs and providing easy, one-man installation.

The meter produces a sine-wave signal proportional to its volumetric flow rate. With optional Blancett electronics, QuikSert provides local flow rate and volume totalization and will interface with most instruments, PLCs and computers.

Operating Principle

Fluid entering the meter first passes through an inlet flow straightener that reduces its turbulent flow pattern. Fluid then passes through the turbine, causing the turbine to rotate at a speed proportional to fluid velocity. As each turbine blade passes through the magnetic field generated by the meter's magnetic pick-up, an AC voltage pulse is generated. These pulses provide an output frequency that is proportional to volumetric flow.

Specifications

Materials of Construction:

- Body and internal wetted parts: 316L Stainless Steel
- Bearings: Tungsten Carbide
- Turbine: CD4MCU Stainless Steel
- Shaft: Tungsten Carbide

Accuracy: ±1% of reading

Repeatability: ±0.1%

Calibration: Water

NIST Traceable Calibration Certificate available, consult factory for details

Pressure Rating: Refer to Pressure Rating Chart on page 3

Operating Temperature: -150 °F to +350 °F
(-101 °C to +177 °C) standard

Temperatures to +450 °F (+232 °C) with high-temp pickup, consult factory for details

End Connections: Wafer-style ASME/ANSI B16.5-1996

Repair Kits

Factory calibrated repair kits are available for field or factory service. This is of particular importance when fluids contain abrasive contaminants and meters require frequent service.

A repair kit contains six screws, two rotor supports, one rotor assembly, and a K-Factor tag. The rotor support assembly is retained in proper position within the meter body by the support screws. These screws allow for quick and easy disassembly and replacement of the meter's internal components. QuikSert repair kits are designed and manufactured for use with Blancett turbines and other flow meters of similar design; contact the factory or refer to Form #4300 (Turbine Flow Meter Repair Kits) for further details.



K-Factor

The K-Factor represents the number of output pulses transmitted per gallon of fluid passing through the turbine meter. Each turbine has a unique K-Factor. However, turbine meters are not functionally consistent throughout the full flow range of the meter.

There are several forms of "friction" inherent in turbine meters that retard the rotational movement of the turbine rotor. These frictional forces include: magnetic drag, created by electromagnetic force of pickup transducers; mechanical drag, due to bearing friction; and viscous drag, produced by flowing fluid. See charts below.

As flow increases, the frictional forces are minimized and the free-wheeling motion of the turbine rotor becomes more linear (proportional to flow). The K-Factor becomes relatively constant and linear throughout the balance of the linear flow range. This is approximately a 10:1 turndown ratio from the maximum flow rate down to the minimum flow rate.

Typical K-Factor Curve (Pulses per Gallon)

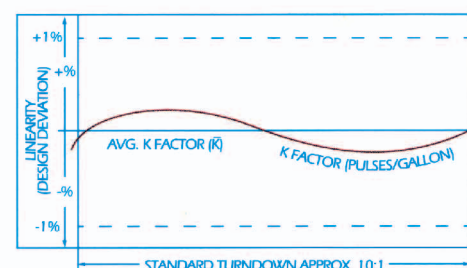
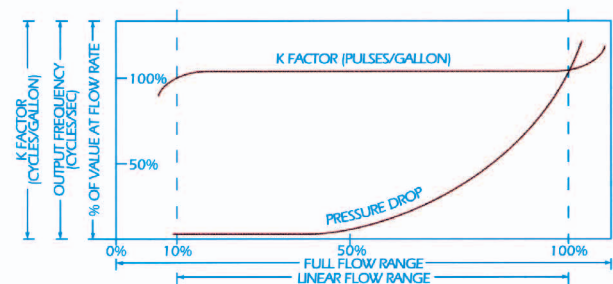

QuikSert Turbine Meters & Repair Kits

Part Number*	Meter Bore Size x Line Size	Flow Ranges			Recommended Strainer	Approx. K-Factor pulses/gal.	Maximum Pressure Drop (psi)	Dimensions Diameter x Length (in)	Repair Kit Part Number
		GPM	BPD	M ³ /D					
B131-038	3/8" x 1"	0.6 - 3	20 - 100	3.3 - 16	60	18,000	3.75	2 x 4	B253-102
B131-050	1/2" x 1"	0.75 - 7.5	25 - 250	4.1 - 41	60	13,000	6.5	2 x 4	B253-105
B131-075	3/4" x 1"	2 - 15	68 - 515	10.9 - 81.75	60	3,300	18	2 x 4	B253-108
B131-088	7/8" x 1"	3 - 30	100 - 1,000	16 - 160	60	3,100	20	2 x 4	B253-109
B131-100	1" x 1"	5 - 50	170 - 1,700	27.25 - 272.5	60	870	20	2 x 4	B253-112
B132-050	1/2" x 2"	0.75 - 7.5	25 - 250	4.1 - 41	60	13,000	12	3.62 x 2.5	B253-205
B132-075	3/4" x 2"	2 - 15	68 - 515	10.9 - 81.75	60	3,300	18	3.62 x 2.5	B253-208
B132-088	7/8" x 2"	3 - 30	100 - 1,000	16 - 160	60	3,100	20	3.62 x 2.5	B253-209
B132-100	1" x 2"	5 - 50	170 - 1,700	27.25 - 272.5	40	870	20	3.62 x 2.5	B253-212
B132-150	1-1/2" x 2"	15 - 180	515 - 6,000	82 - 981	20	330	16	3.62 x 2.5	B253-216
B132-200	2" x 2"	40 - 400	1,300 - 13,000	218 - 2,180	20	52	9	3.62 x 2.5	B253-220
B133-300	3" x 3"	60 - 600	2,100 - 21,000	327 - 3,270	10	57	10	5 x 4.25	B253-330
B134-400	4" x 4"	100 - 1,200	3,400 - 41,000	545 - 6,540	10	29	10	6.18 x 5	B253-440
B136-600	6" x 6"	200 - 2,500	6,800 - 86,000	1,090 - 13,626	4	7	10	8.5 x 5.75	B253-660
B138-800	8" x 8"	350 - 3,500	12,000 - 120,000	1,363 - 19,076	4	3	10	10.62 x 6.25	B253-880
B139-900	10" x 10"	500 - 5,000	17,000 - 171,000	2,725 - 27,252	4	1.6	10	12.75 x 6.75	B253-990

* Part number includes turbine meter and standard magnetic pickup. For other pickup options, see table below. For larger sizes, consult factory.

QuikSert Installation Kits

QuikSert Installation Kits are offered to make set up trouble-free and assure the proper fit. Each kit includes: studs, nuts, gaskets, and spacer rings. See chart below for ordering information.

Size	150#	300#	600#	900#	1500#
1"	B253-1HK-150	B253-1HK-300	B253-1HK-600	B253-1HK-900	B253-1HK-1500
2"	B253-2HK-150	B253-2HK-300	B253-2HK-600	B253-2HK-900	B253-2HK-1500
3"	B253-3HK-150	B253-3HK-300	B253-3HK-600	B253-3HK-900	B253-3HK-1500
4"	B253-4HK-150	B253-4HK-300	B253-4HK-600	B253-4HK-900	B253-4HK-1500
6"	B253-6HK-150	B253-6HK-300	B253-6HK-600	B253-6HK-900	B253-6HK-1500
8"	B253-8HK-150	B253-8HK-300	B253-8HK-600	B253-8HK-900	B253-8HK-1500
10"	B253-9HK-150	B253-9HK-300	B253-9HK-600	B253-9HK-900	B253-9HK-1500

QuikSert Diagrams

Model B132-050 through model B139-900

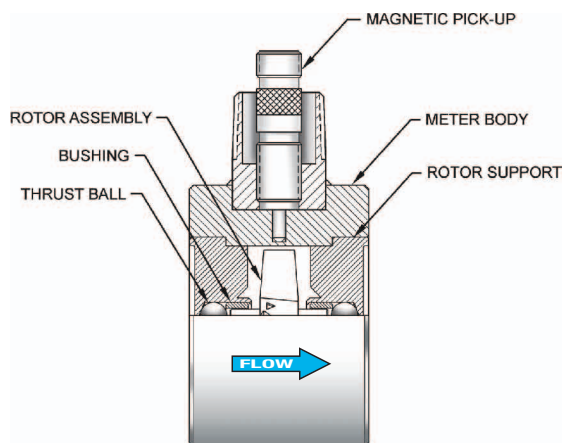

QuikSert Pickup Options

Part Number	Magnetic Pickup	Temperature Range
B111109	Standard	-150 °F to + 330 °F (-101° C to +165° C)
B220111	High Temperature	-450 °F to + 450 °F (-268° C to +232° C)
B220210	with Preamplifier	-40 °F to + 250 °F (-40° C to +121° C)
B220243	Intrinsically Safe, FM rated	-40 °F to + 250 °F (-40° C to +121° C)

Pressure Rating Chart

The pressure rating of the meter is dependent upon the class of ANSI flanges between which the meter is to be mounted. The pressure rating chart below is based on Carbon Steel at 100 °F (37.8 °C).

Flange Class (ANSI)	150	300	600	900	1500
Working Pressure (psi)	285	740	1480	2220	3705
Working Pressure (MPa)	1.97	5.10	10.20	15.31	25.55
* Test Pressure (psi)	427.5	1110	2220	3330	5557.5
* Test Pressure (MPa)	2.95	7.65	15.31	22.98	38.32

* Test pressure based on 1.5 safety factor

Model B131-038 through model B131-100

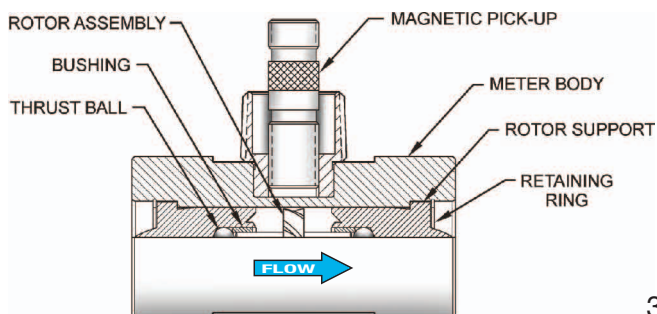

Related Blancett Products

B2800 Flow Monitor

- Microprocessor-based flow monitor and totalizer
- Use with Blancett turbine flow meters as well as other flow meters with a frequency output
- Battery (1.5 VDC) and loop-powered (4-20 mA) versions
- Meter, remote, panel and swivel mounting options
- Hand-held and explosion-proof models also available
- CSA and CE approved
- Class 1, Division 1 (Intrinsically Safe) certification



K-Factor Scaler Frequency Divider

- Scales turbine meter output to desired engineering units
- Amplifies turbine meter pulse output
- Converts frequency outputs into recognizable units for PLCs and other devices
- Switch-selectable or programmable versions available
- CSA approved



F to I / F to V Intelligent Converter

- Microprocessor-based
- Linearized output capability
- Choice of 4-20 mA or 0-5 VDC output
- Enables integration with data acquisition devices
- Frequency measurement accuracy $\pm 1\%$
- CSA approved



Blancett
Flow Meters
Division of Racine Federated Inc.

■ 8635 Washington Avenue, Racine, WI 53406-3738 U.S.A.

■ Toll Free: 1-800-235-1638 Tel: 1-262-639-6770 Fax: 1-262-639-2267

■ E-mail: info@blancett.com

© 2005 Blancett Printed in USA 2/05 Form No. 1300

Blancett is a registered trademark of Racine Federated Inc.
QuikSert is a trademark of Racine Federated Inc.