

Model GFC thermal Mass Flow Controllers are designed to indicate and control set flow rates of gases.

The GFC combines the characteristics, and accuracy of conventional mass flow devices into a unique compact design at low costs previously unattainable.

Each of these controllers incorporates an advanced straight tube sensor in conjunction with flow passage elements constructed of aluminum and brass for non-corrosive gases or 316 stainless steel for corrosive applications. Zero and span adjustments are accessible from the outside of transmitters.

## Principles of Operation

Metered gases are divided into two laminar flow paths, one through the primary flow conduit, and the other through a capillary sensor tube.



**Typical Stainless Steel  
GFC Mass Controller**

## Design Features

- Rigid metallic construction.
- Maximum pressure of 1000 psig (70 bars).
- Leak integrity  $1 \times 10^{-7}$  smL/sec of helium.
- NIST traceable certification.
- Built-in tiltable LCD readout.
- Local or remote setpoint control.
- 0-5 Vdc and 4-20 mA signals.
- Circuit protection.
- Totalizer option.

Both flow conduits are designed to ensure laminar flows and therefore the ratio of their flow rates is constant.

Two precision temperature sensing windings on the sensor tube are heated, and when flow takes place, gas carries heat from the upstream to the downstream windings. The resultant temperature differential is proportional to the change in resistance of the sensor windings.

A Wheatstone bridge design is used to monitor the temperature dependent resistance gradient on the sensor windings which is linearly proportional to the instantaneous rate of flow.

Output signals of 0 to 5Vdc and 4 to 20mA are generated indicating mass molecular based flow rates of the metered gas.

The combined gas streams flow through a proportionating electromagnetic valve with an appropriately selected orifice. The closed loop control circuit continuously monitors the mass flow output and maintains it at the set flow rate.

Flow rates are unaffected by temperature and pressure variations within stated limitations.

## General Description

Compact, self contained GFC mass flow controllers are designed to indicate and control flow rates of gases. The rugged design coupled with instrumentation grade accuracy provides versatile and economical means of flow control. Aluminum or stainless steel models with readout options of either engineering units (standard) or 0 to 100 percent displays are available.

The built-in electromagnetic valve allows the flow to be set to any desired flow rate within the range of the particular model. The valve is normally closed as a safety feature to ensure that gas flow is shut off in case of a power outage. Setpoints are controlled either locally or remotely.

The LCD readout built into the top of the transducer is tiltable over 90 degrees to provide optimal reading comfort. It is connected to the transducer by a standard modular plug, and is readily removable for remote reading installations. Transducers without LCD readout are offered for OEM applications.

GFC mass flow controllers are available with flow ranges from 10 sccm to 1000 sL/min N<sub>2</sub>. Gases are connected by means of 1/4", 3/8", or optional 1/8" compression fittings and 3/4" FNPT fittings. Optional fittings are available. These controllers may be used as bench top units or mounted by means of screws in the base.

Transducer power supply ports are fuse and polarity protected.

## Leak Integrity

1 x 10<sup>-7</sup> smL/sec of helium maximum to the outside environment.

## Specifications

### ACCURACY (including linearity):

±1.5% of full scale, including linearity for gas temperatures of 59°F to 77°F (15°C to 25°C) and pressures of 5 to 60 psia (0.4 to 4.1 bars). Optional ±1% of full scale (certified calibration accuracy) associated with a given set of temperature and pressure values.

### REPEATABILITY:

±0.5% of full scale.

### RESPONSE TIME:

Generally 2 seconds to within ±2% of actual flow rate over 25 to 100% of full scale.

### TEMP. COEFFICIENT:

0.15% of full scale /°C.

### PRESSURE COEFFICIENT:

0.01% of full scale /psi (0.07 bar).

### PRESSURE DROP:

See table below.

### OPTIMUM GAS PRESSURE:

25 psig (1.73 bars).

### MAX GAS PRESSURE:

1000 psig (70 bars) maximum.

### MAX DIFF. PRESSURE:

GFC17 and GFC37 50psi (3.4 bars),  
GFC47 40 psi (2.7 bars).

### GAS and AMBIENT TEMP:

41°F to 122°F (5°C to 50°C).

### MATERIALS FLUID CONTACT:

- A. Aluminum models GFC Series: anodized aluminum, 316 stainless steel, brass and Viton® O-rings.
- B. Stainless Steel models GFC17S, 37S, 47S, 57S, 67S and 77S: 316 stainless steel and Viton® O-rings. Optional O-rings Neoprene® and Kalrez®.

### ATTITUDE SENSITIVITY:

No greater than ±15 degree rotation from horizontal to vertical; standard calibration is in horizontal position.

### OUTPUT SIGNALS:

Linear 0-5 Vdc. (1000 ohms min. load impedance);  
4-20 mA (0-500 ohms loop resistance) Max noise ±20mV.

### COMMAND SIGNALS:

Analog 0-5 Vdc or 4-20 mA for remote set point mode;  
NPN compatible purge /valve off.

### CONNECTIONS:

**GFC 17 and 37:** 1/4" compression fittings.  
**GFC 47:** 3/8" compression fittings.  
Optional: VCR® 1/8" compression fittings (GFC17).  
**GFC 57:** 3/8" compression fittings.  
**GFC 67:** 1/2" compression fittings.  
**GFC 77:** 3/4" FNPT fittings.  
Optional: VCR® or 3/4" compression fittings (GFC77).

### LEAK INTEGRITY:

1 x 10<sup>-7</sup> smL/sec of helium maximum to the outside environment.

### TRANSDUCER INPUT POWER:

+12 Vdc, 800 mA; +24 Vdc, 650 mA optional.

### CIRCUIT PROTECTION:

Circuit boards have built-in polarity reversal protection. Resettable fuses provide power input protection.

### DISPLAY:

3-1/2 digit LCD, 0.5" high characters.

### CE COMPLIANT:

EN 55011 class 1, class B; EN50082-1

MODEL	FLOW RATE [std liters/min]	MAXIMUM PRESSURE DROP		
		[mm H <sub>2</sub> O]	[psid]	[mbar]
GFC 17	UP to 10	720	1.06	75
	15	2630	3.87	266
GFC 37	20	1360	2.00	138
	30	2380	3.50	241
	40	3740	5.50	379
	50	5440	8.00	551
GFC 47	60	7480	11.00	758
	100	12850	18.89	1302
GFC 57	200	7031	10.00	690
GFC 67	500	8437	12.00	827
GFC 77	1000	10547	15.00	1034

## GFC 57, 67 and 77 Aluminum Mass Flow Controllers



### GFC 17 LOW FLOW MASS FLOW CONTROLLER\*

MODEL	CODE	scc/min [N <sub>2</sub> ]	CODE	std liters/min [N <sub>2</sub> ]
GFC17	-01	0 to 10	07	0 to 1
	-02	0 to 20	08	0 to 2
	-03	0 to 50	09	0 to 5
	-04	0 to 100	10	0 to 10
	-05	0 to 200		
	-06	0 to 500		

### GFC 37 MEDIUM FLOW MASS FLOW CONTROLLER\*

MODEL	CODE	std liters/min [N <sub>2</sub> ]
GFC37	-11	0 to 15
	-30	20
	-31	30
	-32	40
	-33	50

### GFC 47 /57 /67 /77 HIGH FLOW MASS FLOW CONTROLLER\*

MODEL	CODE	std liters/min [N <sub>2</sub> ]
GFC47	-40	60
	-41	80
	-42	100
GFC57	-50	200
GFC67	-60	500
GFC77	-70	1000

### TABLE 13 - TOTALIZER

TOT-10-0C	Totalizer (5Vdc - 10Vdc signals), calibrated.
TOT-10-0N	Totalizer (5Vdc - 10Vdc signals), uncalibrated.
CBL-TOT10	Cable & splitter, used in conjunction w/ display.

### TABLE 14 - IO INPUT/OUTPUT

I0-232-C	Input/output to RS232, 0-5Vdc.
I0-232-E	Input/output to RS232, 4-20mA.
I0-485-C	Input/output to RS485, 0-4Vdc.
I0-485-E	Input/output to RS485, 4-20mA.

### TABLE 15 - ACCESSORIES FOR GFC MASS FLOW CONTROLLERS

PS-GFC-110NA-2	Power Supply, 110 V / 12 Vdc /North America
PS-GFC-230EU-2	Power Supply, 220 V / 12 Vdc /Europe
PS-GFC-240UK-2	Power Supply 240 V / 12 Vdc /United Kingdom
PS-GFC-240AU-2	Power Supply 240 V / 12 Vdc /Australia

CBL-DGS	Cable, Shielded 15-pin D-connector /end terminated
17/3RC	Remote Cable, 3 feet long
17/R	Remote LCD readout with 3 feet long cable

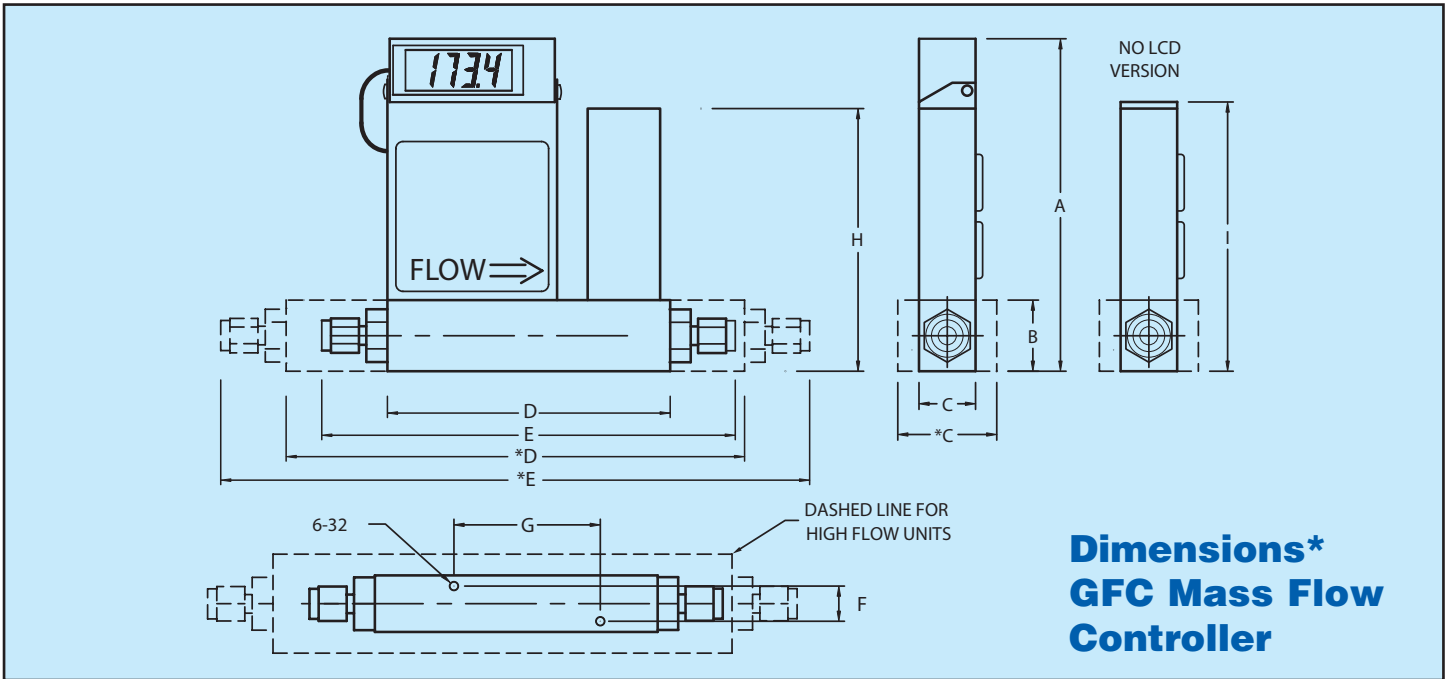

**Dimensions\***  
**GFC Mass Flow Controller**

MODEL	CONNECTION Swagelok® Compression Fitting (except model GFC 77)	DIMENSION (INCH)							
		LCD VERSION							NO LCD
		A	B	C/*C	D/*D	E/*E	F	G	
GFC17	1/4" Tube O Dia.	5.60	1.00	1.00	4.27	6.29	0.69	2.69	4.50
GFC37	1/4" Tube O Dia.	5.98	1.37	1.25	5.19	7.21	0.69	2.69	4.88
GFC47	3/8" Tube O Dia.	5.98	1.37	1.25	5.19	7.33	0.69	2.69	4.88
GFC57	3/8" Tube O Dia.	6.60	2.00	1.75	10.2	12.3	0.99	4.69	5.50
GFC67	1/2" Tube O Dia.	7.56	3.00	3.00	10.2	12.4	-	-	6.46
GFC77	3/4" NPT Female	8.56	4.00	4.00	10.5	-	-	-	7.46

**NOTE:**  
**Only 12Vdc for models GFC 57, 67 and 77.**

*For Specific Flow Ranges  
Contact Aalborg  
Customer Service Department.*

SERIES	MAX. FLOW (N <sub>2</sub> )	MATERIAL	SEALS	FITTINGS	CONNECTOR	DISPLAY	POWER	INPUT/OUTPUT SIGNAL	DIGITAL INTERFACE
17	10 L/min	A Aluminum	V Viton	A 1/4" Compression	D D Connector	N No display	2 12 Vdc	A Local 0-5 Vdc	0 None
37	50 L/min	S Stainless	B Buna	B 1/8" Compression		L LCD readout	4 24 Vdc	B Local 4-20mA	
47	100 L/min		E EPR	C VCR				C 0-5Vdc/0-5Vdc	
57	200 L/min		T PTFE/Kalrez	D 3/8" Compression				D 0-5Vdc/4-20mA	
67	500 L/min			E 1/2" Compression				E 4-20mA/4-20mA	
77	1000 L/min			F 3/4" FNPT				F 4-20mA/0-5Vdc	
				G 3/4" Compression					
				X Special					

**EXAMPLE: GFC17S-VADL2-C0** 10 L/min [N<sub>2</sub>] 20 psig **PLEASE SPECIFY: Gas, Flow Range and Pressure.**  
GFC17 stainless, Viton seals, 1/4" compression fittings, D connector with display, 12Vdc, 0-5 Vdc. Out Put Signal, No Digital Interface.

## ORDERING INFORMATION FOR GFC

BULLETIN FM200408 GFC