

ULTRASONIC FLOWMETER TIME DELTA-C

The latest advance in high performance transit time flow measurement
 Superior signal processing and best-in-class anti-bubble performance in a compact and lightweight package



Detector (FLS)



Flow transmitter (FSV...S)

- **High accuracy measurement** : 1.0% of rate
- **Superior anti-bubble performance** : Our Advanced ABM method * is adopted.
- **Maintenance free operation** : Non-invasive setup with no moving parts
- **Compact and lightweight** : Size and mass reduced by 2/3 (compared with model FLV).
- **Flexible communication functions** : RS-232C or RS-485 (MODBUS) (option)
- **Wide application range** : $\phi 13$ to $\phi 6000$ mm applicable pipe diameters
- **Quick and easy setup** : Simple menu guided setup from the front panel or PC interface

* Advanced ABM method: anti-bubble measuring method.

Fuji Electric Systems Co., Ltd.

Applicable pipe diameter is $\phi 13\text{mm}$ to $\phi 6000\text{mm}$

- High accuracy measurement of fluid flow rate: 1.0% of rate
- Quick response: 0.2 sec. or less (quick response mode)
- Minimal Influence by the pressure of measured fluid and temperature
- Superior anti-bubble performance
(Advanced AMB method * is adopted.)

* Advanced AMB method: anti-bubble measurement method

- Advanced received signal digital processing results in higher performance flow measurement

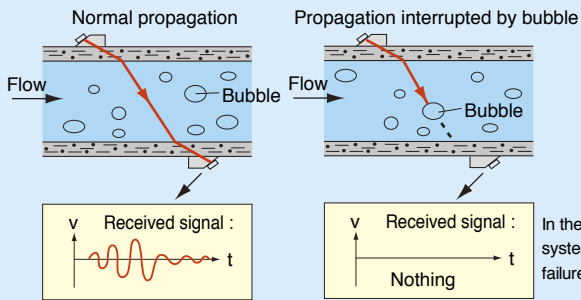

In the case of an analog system, measurement failure will occur.

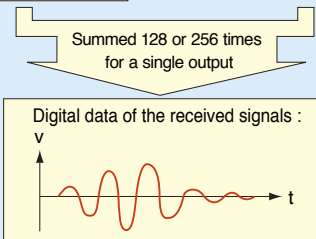

Synchronized summation of received signals

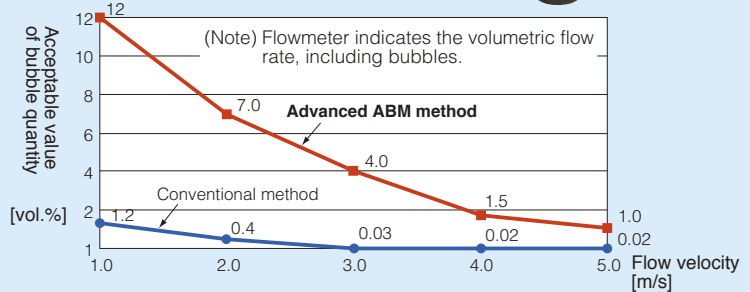

- A wide range of detectors is available, and no piping work is required
(A detector is simply attached to the exterior of the piping.)

Classification	Appearance	Detector type	Applicable pipe inner diameter (mm)	Measured fluid temperature	Mounting/structure
Compact type		FLSE1	$\phi 25$ to $\phi 100$	-20 to 100°C or 0 to 120°C	<ul style="list-style-type: none"> · V method mounting · Jet structure (equivalent to IP65)
		FLSE2	$\phi 50$ to $\phi 225$		
Small diameter type		FLD2	$\phi 13$ to $\phi 100$	-40 to 100°C	<ul style="list-style-type: none"> · V mounting method · Watertight structure (equivalent to IP67)
High temperature type		FLD3	$\phi 50$ to $\phi 400$	-40 to 200°C	<ul style="list-style-type: none"> · V or Z method mounting · Splash-proof structure (equivalent to IP52)
Common type		FLW1	$\phi 50$ to $\phi 300$	-40 to 80°C	<ul style="list-style-type: none"> · V method mounting · Watertight structure (equivalent to IP67) · Submersible type available
Large diameter type		FLW4	$\phi 200$ to $\phi 1200$	-40 to 80°C	<ul style="list-style-type: none"> · V or Z method mounting · Watertight structure (equivalent to IP67) · Submersible type available
		FLW5	$\phi 200$ to $\phi 6000$		

Measuring principle

With ultrasonic pulses propagated diagonally between the upstream and downstream sensors mounted on the exterior of the pipe, the flow rate is measured by detecting the time difference caused by the flow.

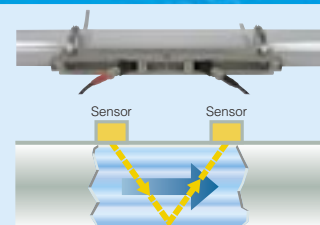

Both the mass and volume of the flow transmitter are reduced by 2/3!

■ Compact and lightweight flow transmitter (1/3 size of model FLV)

Easy to carry and install on a system

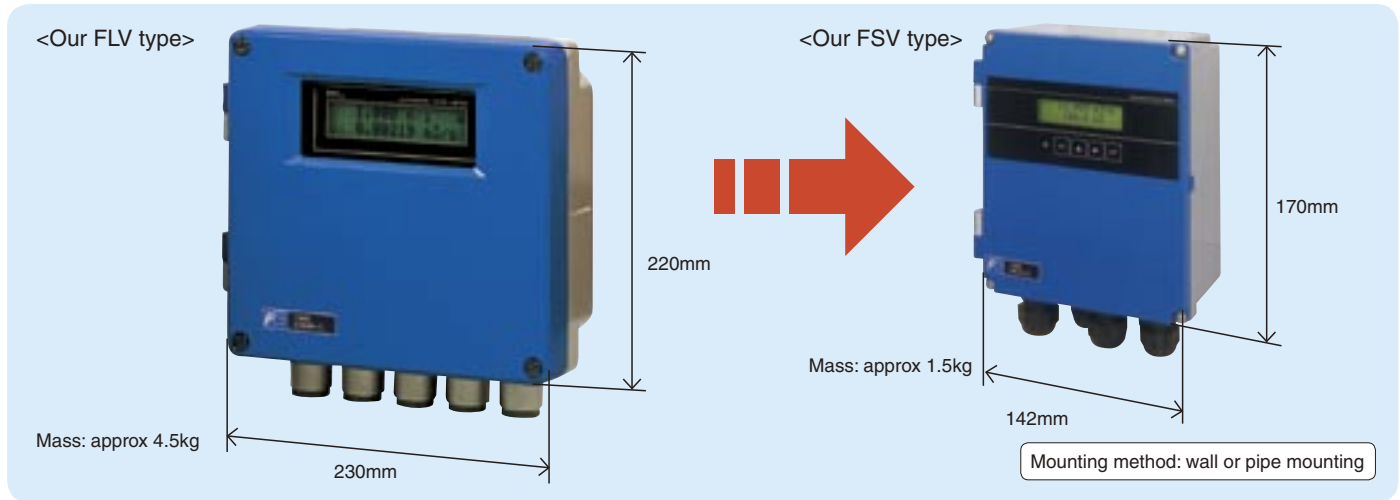

■ Operation can be performed from the outside panel (In case of IP66 type)

Various settings can be made from the front side without opening the cover of the flow transmitter. (Parameter setting, input of mounted pipe data, automatic calculation of mounting dimensions and similar)

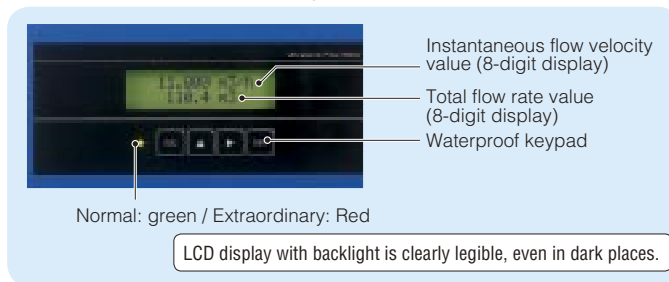

■ Parameter setting and data collection can be performed via optional PC communications interface.

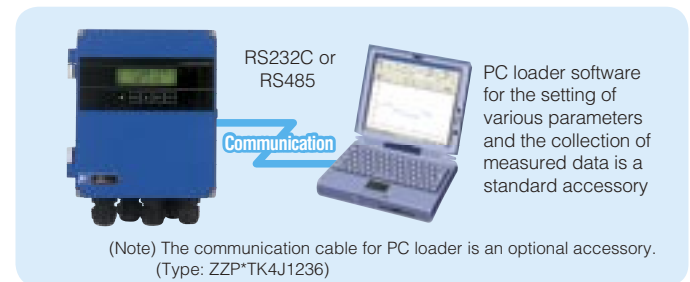

■ Signal and process interfaces are designed with functionality as priority.

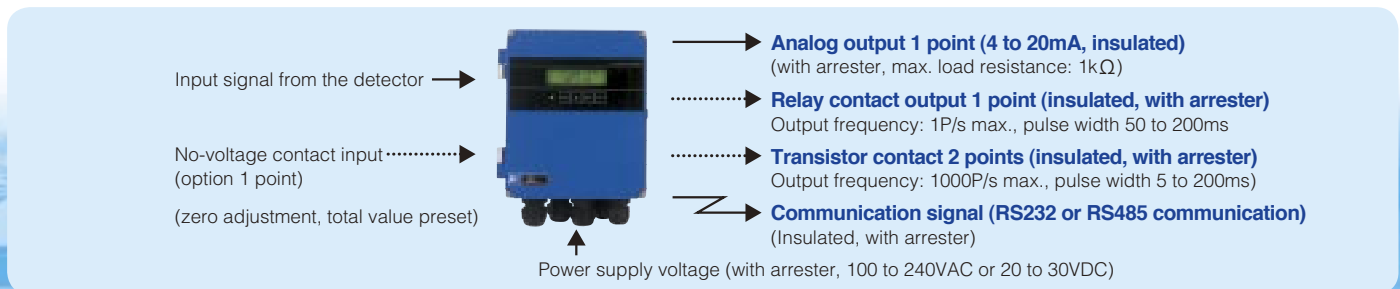

■ Fully equipped with extensive functions

Zero adjustment	one-touch adjustment while the flow is stopped
Damping	Used to reduce the fluctuation of the measured value. Setting range: 0 to 100 sec. (setting per 0.1 sec.)
Low flow rate cut	Output may be cut when the flow rate is low. Setting range: 0 to 5m/s (setting in 0.01m/s unit)
Alarm contact output	Contact output at condition of hardware and process faults
Output burnout	When measurement cannot be made because the pipe is empty or bubbles are entrained in the fluid, contact output is activated while analog output is held.
Forward and backward ranges	Ranges may be set arbitrarily. The digital output of the operation range is available.
Auto 2-range	2 forward ranges are independently configurable. Digital output of operation is available.
Flow switch	Contact output is made when the upper or lower limit values of the instantaneous flow rate are reached
Total value switch	Contact output is made when the upper limit value of the total flow rate (forward) exceeds the setting value.
Display of various units	Unit may be set in m/s, L/s, L/min, L/h, L/d, KL/d, ML/d, m ³ /s, m ³ /min, m ³ /h, m ³ /d, Km ³ /d, Mm ³ /d
Multilingual display	The display language may be selected from 5 choices, including Japanese (Katakana), English, French, Spanish and German.

Application example

The ultrasonic flowmeter is a liquid flowmeter used in various applications.

1. Measuring system for the paint flow rate

The flow rate of thick paint is measured by a detector mounted on the pipe already constructed.

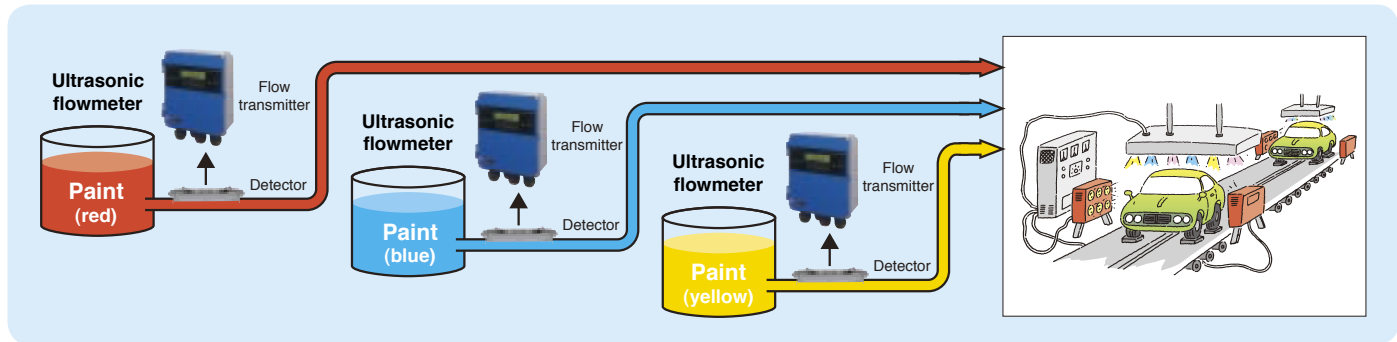

2. An energy-saving system for measuring and controlling the flow rate of a pump

A detector is attached to the already constructed pipe to measure the flow rate at the pump outlet, and a regulator is used to implement inverter control of the pump.

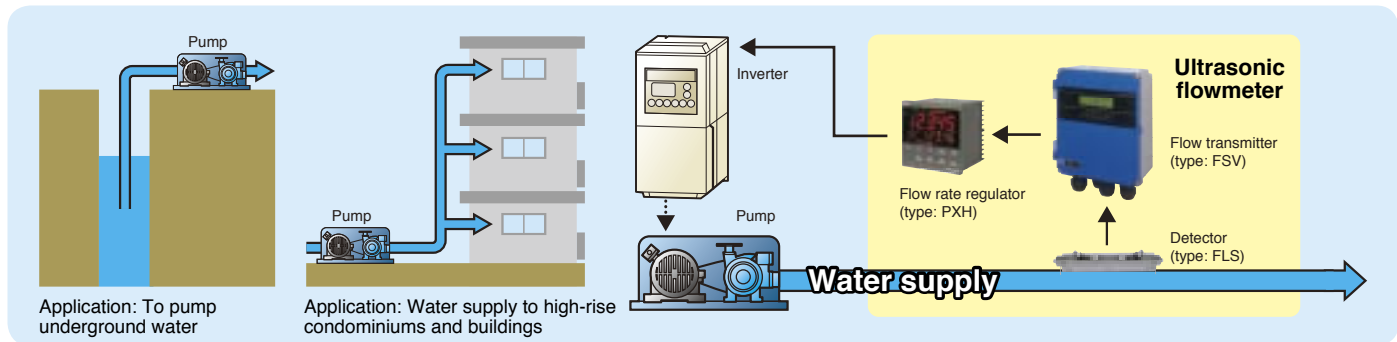

3. Flow rate measurement in a water purifying system for semi-conductors

Advantages of using an ultrasonic flowmeter for the system

- 1) It can be easily mounted on the exterior of a pipe, helping reduce mounting cost.
- 2) As a sensor, it can operate without coming into contact with fluid, so the fluid is not affected by metallic ions.
- 3) This meter, compact and lightweight, can be easily carried and mounted.

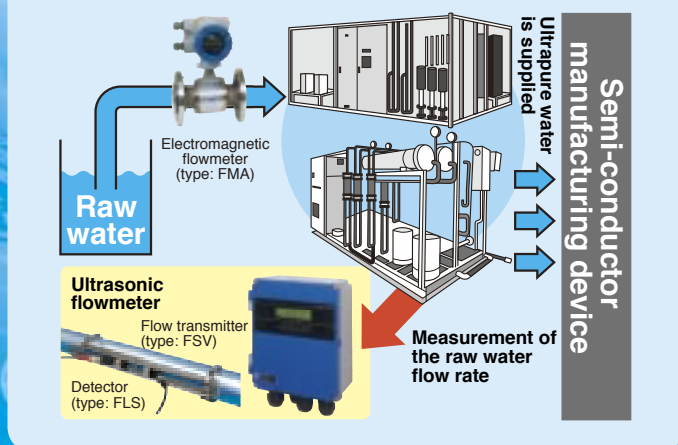

4. A system for measuring heat transfer and efficiency

Heat is transferred by water flow in the process of HVAC loop

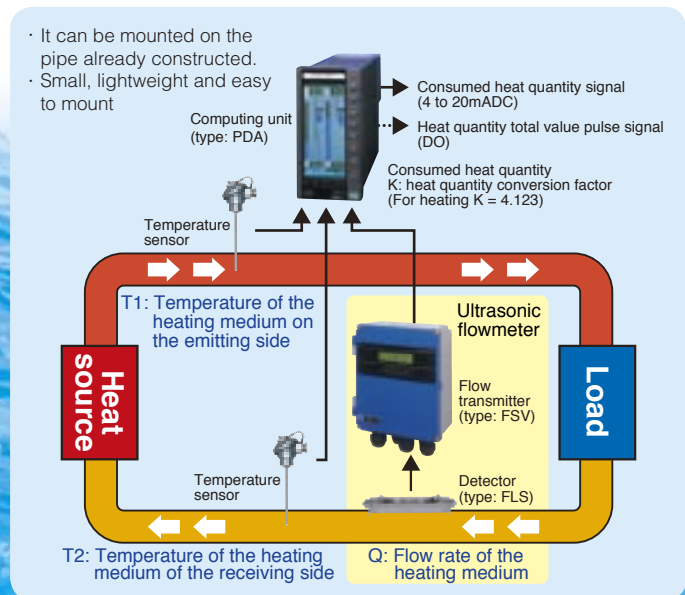

Major applications



- Backup for the already constructed flowmeter
- Water supply and sewage systems leakage investigation of water pipe and investigation of the flow direction in the water distribution pipe
- Power plant flow rate measurement of the boiler water supply, condenser circulating pump and turbine oil
- Various plants flow rate measurement of cooling water, plating solution and corrosive liquid
- Food manufacturing plant flow rate measurement of raw material and washing water
- Semiconductor manufacturing plant flow rate measurement of pure water
- Air-conditioning equipment flow rate measurement of hot water and chilled water in heating and cooling
- Hot spring Measurement of suction quantity

Specifications

Applicable subjects and operation environment

Applicable fluid	Homogeneous liquids capable of ultrasonic wave propagation Bubble quantity: 0 to 12Vol% (reference diameter 50A, water and flow velocity of 1m/s) Turbidity of fluid: 10000 degrees (mg/L) or less Straight pipe length: upstream side 10D or more, downstream 5D or more (D: pipe inner diameter) State of flow: fully developed turbulent or laminar flow in round pipe filled with fluid					
Applicable piping and fluid temperature	Classification	Detector type	Pipe inner diameter (mm)	Applicable pipe material	Mounting method	Fluid temperature range (Note 3)
	Compact type	FLSE12	$\phi 25$ to $\phi 100$	Plastic (PVC, etc.) (Note 1)	V method	The 9th digit of the code symbols Y : -20 to 100°C A : 0 to 120°C (Note 4) Heat shock resistance 150°C for 30 min.
			$\phi 50$ to $\phi 100$	Metal pipe (SS, steel pipe, copper pipe, aluminum pipe, etc.) (Note 2)		
	FLSE22	$\phi 50$ to $\phi 225$	Plastic (PVC, etc.) (Note 1) Metal pipe (SS, steel pipe, copper pipe, aluminum pipe, etc.) (Note 2)			
	Small diameter type	FLD22	$\phi 13$ to $\phi 100$	Plastic (PVC, etc.) (Note 1) Metal pipe (SS, steel pipe, copper pipe, aluminum pipe, etc.) (Note 2)		
	Common type	FLW11, 12	$\phi 50$ to $\phi 300$	Plastic (PVC, etc.) (Note 1) Metal pipe (SS, steel pipe, copper pipe, aluminum pipe, etc.) (Note 2)	V method	-40 to 80°C
	Large diameter type	FLW41	$\phi 200$ to $\phi 1200$			
		FLW50, 51	$\phi 200$ to $\phi 6000$		V or Z method	-40 to 200°C
High temperature type	FLD32	$\phi 50$ to $\phi 400$				
<p>Note 1: If the pipe material is PP or PVDF, select FLW1, FLW4 or FLW5. Note that the wall thickness is 15mm or less for PP, 9mm or less for PVDF.</p> <p>Note 2: For cast iron pipes, lining pipes, old steel pipes or similar, through which the ultrasonic signal cannot easily be transmitted, select FLW11, FLW41 or FLW50. Lining material: Tar epoxy, mortar, rubber, etc.</p> <p>* In case the lining suffers from peeling-off, measurement may be impossible.</p> <p>Note 3: If silicone-free grease is used as an acoustic couplant, the fluid temperature range is 0 to 60°C, regardless of the detector.</p> <p>Note 4: When the 9th digit in the code symbol is "A", the applicable piping diameter is up to 150mm.</p>						
Flow velocity range	0 to $\pm 0.3 \dots \pm 32$ m/s					
Power supply voltage	100 to 240VAC 50/60Hz or 20 to 30VDC					
Power consumption	15VA or less (AC power supply), 6W or less (DC power supply)					
Signal cable (between the detector and converter)	Coaxial cable (60m max. for compact type detector (FLS), 300m max. for other others) Heat resistance: 80°C					
Installation environment	Non-explosive area not exposed to direct sunlight, corrosive gas or heat radiation					
Ambient temperature	Flow transmitter: -20 to 55°C Detector: -20 to 60°C or -20 to 80°C (FLSE2□2□-A)					
Ambient moisture	95% RH max.					
Grounding	Class D (100Ω)					
Arrester	Provided as standard at the output and power supply					

Performance specifications

Accuracy rating	Classification	Detector type	Pipe size (inner diameter)	Accuracy	Flow velocity	Applicable pipe material	
Compact type	FLSE12	$\phi 25$ to $\phi 50$		2.0% of rate	2 to 32m/s	Plastic	
				0.04m/s	0 to 2m/s		
		$\phi 50$ to $\phi 100$		1.0% of rate	2 to 32m/s		
				0.02m/s	0 to 2m/s		
		$\phi 50$ to $\phi 100$		2.0% of rate	2 to 32m/s		Metal pipe
				0.04m/s	0 to 2m/s		
	FLSE22	$\phi 50$ to $\phi 225$		1.0% of rate	2 to 32m/s	Plastic	
				0.02m/s	0 to 2m/s		
		$\phi 50$ to $\phi 225$		2.0% of rate	2 to 32m/s		Metal pipe
				0.04m/s	0 to 2m/s		
	Small diameter type	FLD22	$\phi 13$ to $\phi 50$		2.5% of rate	2 to 32m/s	Plastic, metal pipe
					0.05m/s	0 to 2m/s	
$\phi 50$ to $\phi 100$				1.5% of rate	2 to 32m/s		
				0.03m/s	0 to 2m/s		
Common type	FLW12	$\phi 50$ to below $\phi 300$	1.0% of rate	2 to 32m/s			
High temperature type	FLD32		0.02m/s	0 to 2m/s			
Large diameter type	FLW51	$\phi 300$ to $\phi 6000$	1.0% of rate	1 to 32m/s			
			0.01m/s	0 to 1m/s			
Common type	FLW11	$\phi 50$ to below $\phi 300$	1.5% of rate	2 to 32m/s			
			FLW41	0.03m/s	0 to 2m/s		
				FLW50	1.5% of rate	1 to 32m/s	
0.015m/s	0 to 1m/s						
Response time	0.5 sec. (standard mode), 0.2 sec. depending on setting (quick response mode)						

Functional specifications

Analog signal	4 to 20mA DC (1 point), Load resistance: 1kΩ max.										
Digital output	Forward total, reverse total, alarm, acting range, flow switch, total switch assignable arbitrarily (1) Mechanical relay contact (isolated, socket provided, arrester incorporated) (2) Transistor contact (isolated, open collector, arrester incorporated) · Output: 1 point · Normal: Open/Close selectable · Contact capacity: 240VAC/30VDC, 1A · Output frequency: 1P/s max. (pulse width: 50, 100, 200ms)										
Digital input (option)	1 point (no-voltage contact)/Set zero, preset total assignable										
Serial communication (option)	RS-232C equivalent or RS-485, isolated, arrester incorporated Connectable quantity: 1 unit (RS-232) /up to 31 units (RS-485: MODBUS) Baud rate: 9600, 19200, 38400bps Parity: None/Odd/Even selectable	Stop bits: 1 or 2 bits selectable Cable length: 15m max. (RS-232C)/1km max. (RS-485) Data: Flow velocity, flow rate, forward total, reverse total, status, etc.									
Display device	2-color LED (Normal: green, Abnormal: red), LCD display (2 lines of 16 digits, back light provided)										
Indication language	Japanese (Katakana), English, French, German, Spanish (switchable)										
Flow velocity / flow rate indication	Instantaneous flow velocity / instantaneous flow rate indication (minus indication for reverse flow) Numerals: 8 digits (decimal point is counted as 1 digit) English and metric units selectable. Unit: <table border="1" style="display: inline-table; vertical-align: middle;"><tr><td></td><td>Metric system</td><td>Inch system</td></tr><tr><td>Velocity</td><td>m/s</td><td>ft/s</td></tr><tr><td>Flow rate</td><td>L/s, L/min, L/h, L/d, kL/d, ML/d, m³/s, m³/min, m³/d, km³/d, Mm³/d, BBL/s, BBL/min, BBL/h, BBL/d, kBBL/d, MBBL/d</td><td>gal/s, gal/min, gal/h, gal/d, kgal/d, Mgal/d, ft³/s, ft³/min, ft³/d, Kft³/d, Mft³/d, BBL/s, BBL/min, BBL/h, BBL/d, kBBL/d, MBBL/d</td></tr></table>			Metric system	Inch system	Velocity	m/s	ft/s	Flow rate	L/s, L/min, L/h, L/d, kL/d, ML/d, m ³ /s, m ³ /min, m ³ /d, km ³ /d, Mm ³ /d, BBL/s, BBL/min, BBL/h, BBL/d, kBBL/d, MBBL/d	gal/s, gal/min, gal/h, gal/d, kgal/d, Mgal/d, ft ³ /s, ft ³ /min, ft ³ /d, Kft ³ /d, Mft ³ /d, BBL/s, BBL/min, BBL/h, BBL/d, kBBL/d, MBBL/d
	Metric system	Inch system									
Velocity	m/s	ft/s									
Flow rate	L/s, L/min, L/h, L/d, kL/d, ML/d, m ³ /s, m ³ /min, m ³ /d, km ³ /d, Mm ³ /d, BBL/s, BBL/min, BBL/h, BBL/d, kBBL/d, MBBL/d	gal/s, gal/min, gal/h, gal/d, kgal/d, Mgal/d, ft ³ /s, ft ³ /min, ft ³ /d, Kft ³ /d, Mft ³ /d, BBL/s, BBL/min, BBL/h, BBL/d, kBBL/d, MBBL/d									
Total indication	Forward or reverse total value indication (negative indication for reverse direction) Numerals: 8 digits (decimal point is counted as 1 digit) English and metric units selectable. Unit: <table border="1" style="display: inline-table; vertical-align: middle;"><tr><td></td><td>Metric system</td><td>Inch system</td></tr><tr><td>Total</td><td>mL, L, m³, km³, Mm³, mBBL, BBL, KBBL</td><td>gal, kgal, ft³, kft³, Mft³, mBBL, BBL, kBBL, ACRE-ft</td></tr></table>			Metric system	Inch system	Total	mL, L, m ³ , km ³ , Mm ³ , mBBL, BBL, KBBL	gal, kgal, ft ³ , kft ³ , Mft ³ , mBBL, BBL, kBBL, ACRE-ft			
	Metric system	Inch system									
Total	mL, L, m ³ , km ³ , Mm ³ , mBBL, BBL, KBBL	gal, kgal, ft ³ , kft ³ , Mft ³ , mBBL, BBL, kBBL, ACRE-ft									
Setting function	Setting available with 4 keys (ESC, △, ▷, ENT) on the flowmeter front										
Zero adjustment	Set zero/Clear available										
External zero adjustment	Set zero available by digital input (option) setting										
Damping	0 to 100s (setting per 0.1 sec.) for analog output and flow velocity/flow rate indication										
Low flow rate cutoff	0 to 5m/s in terms of flow velocity										
Alarm	Digital output available for Hardware fault or Process fault										
Burnout	Analog output: Hold /Over-scale/Under-scale/zero (selectable) Flow rate total: Hold/Count (selectable) Burnout timer: 0 to 100s (every 1s)										
Bi-directional range	Forward and reverse ranges configurable independently / Hysteresis: 0 to 10% of working range / Working range applicable to digital output										
Auto 2-range	2 forward ranges configurable independently / Hysteresis: 0 to 10% of working range / Working range applicable to digital output										
Flow switch	Lower limit, upper limit configurable independently (Digital output available for status at actuated point)										
Total switch	Upper limit of the forward total settable (Digital output available when actuated)										

Physical specifications

Type of enclosure	Flow transmitter: IP66 or IP67 / Detector: IP52/IP65/IP67 (Depend on detector type)				
Mounting method	Mounted on wall or by 2B pipe / Detector: Clamped on existing piping.				
Acoustic couplant	Silicone rubber, silicone grease or silicone-free grease				
Note: The acoustic couplant is a medium that eliminates the gap between detector and pipe.	Type	Silicone rubber (type:KE-348W)	Silicone grease (type:G40M)	Silicone-free grease (type:HIGH Z)	Grease for high temperature (type:KS62M)
	Fluid temperature	-40 to +150°C	-30 to +150°C	0 to +60°C	-30 to +250°C
	Teflon piping	Not usable	Good	Good	Good
Outer dimensions, mass	See outline diagrams.				

Loader software (standard accessory)

Compatible PC model	PC/AT compatible instrument Operation is undefined for PC98 series (NEC)
Main function	Software for setting/change of the main unit parameters and for collection of the measured data on PC
OS	Windows 2000/XP
Memory requirement	125MB min.
Hard disk capacity	Minimum free space of 52MB or more Note: Loader cable (code symbol ZPP * TK4J1236) is additionally required.

Connection diagram

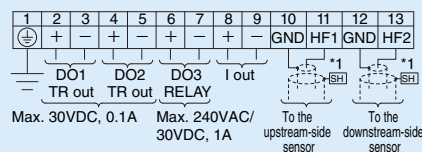
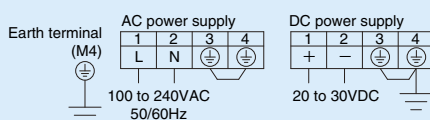

Option

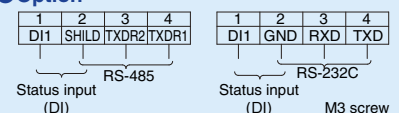

*1 Only for double shield cable (type FLY8, 9)

Outline diagram of the flow transmitter (unit: mm)

●IP66 type Flow transmitter Type: FSV...S (Weight: 1.5kg)

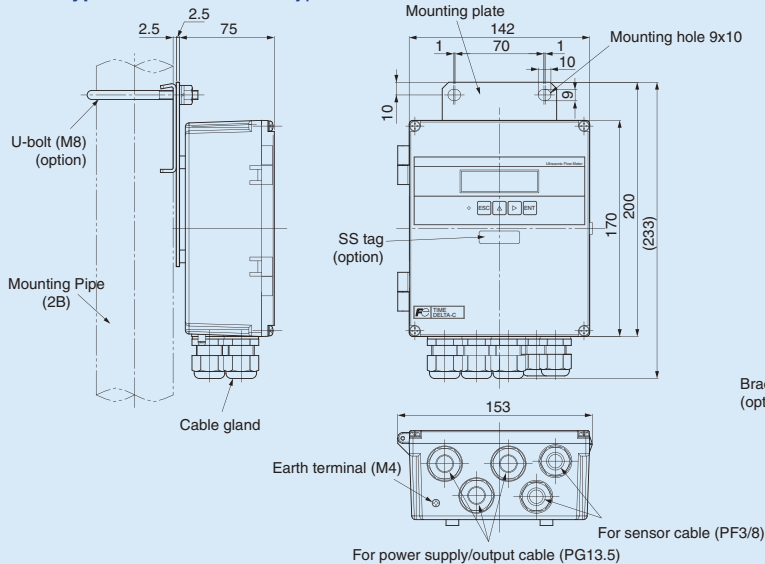

●IP67 type flow transmitter Type FSV...H (Weight: 4.5kg)

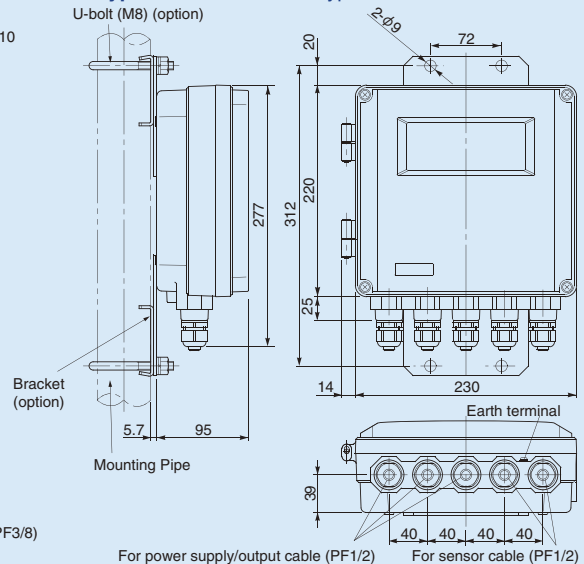

Outline diagram of detector (unit: mm)

●Compact type detector Type: FLSE1 (diameter $\phi 25$ to $\phi 100$) Type: FLSE2 (diameter $\phi 50$ to $\phi 225$)

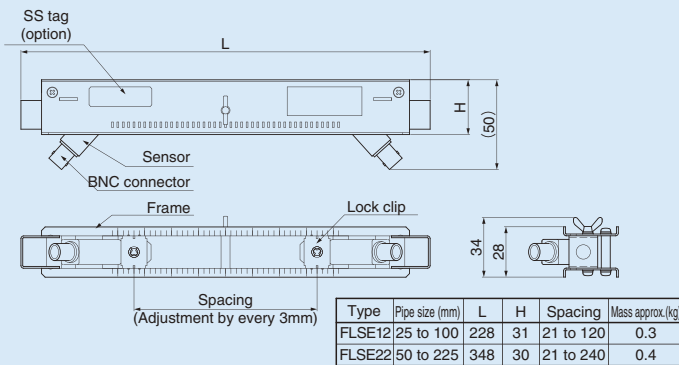

●Common type detector Type: FLW1 (diameter $\phi 50$ to $\phi 300$, Weight: 1kg)

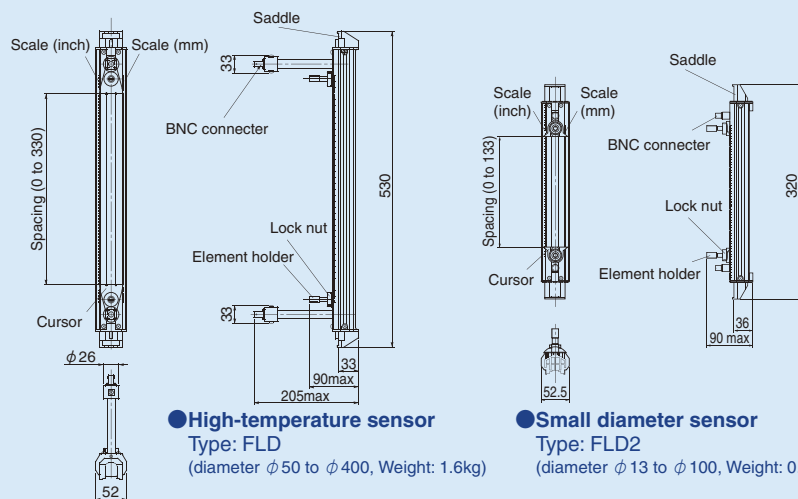
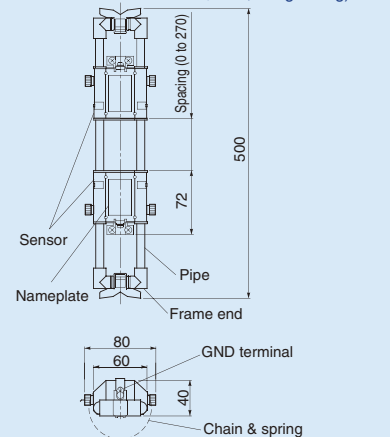

●High-temperature sensor Type: FLD (diameter $\phi 50$ to $\phi 400$, Weight: 1.6kg)

●Small diameter sensor Type: FLD2 (diameter $\phi 13$ to $\phi 100$, Weight: 0.6kg)

●Large diameter sensor Type FLW4 (diameter $\phi 200$ to $\phi 1200$, Weight: 0.4kg)

●Large diameter sensor Type: FLW5 (diameter $\phi 200$ to $\phi 6000$, Weight: 1.4kg)

Fuji Electric Systems Co., Ltd.

Sales Div. III, International Sales Group
Global Business Group

Gate City Ohsaki, East Tower, 11-2, Osaki 1-chome,
Shinagawa-ku, Tokyo 141-0032, Japan

<http://www.fesys.co.jp/eng>

Phone: 81-3-5435-7280, 7281 Fax: 81-3-5435-7425

<http://www.fic-net.jp/eng>