

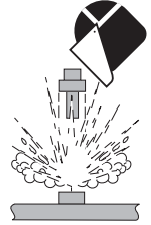

## SAFETY INSTRUCTIONS



1. Depressurize and vent systems without Hot-tap valve prior to installation or removal.
2. Confirm chemical compatibility before use.
3. Do not exceed maximum temperature/pressure specifications.
4. Wear safety goggles or face shield during installation/service.
5. Do not disassemble or alter product construction.
6. Disconnect power before attempting any service or wiring.



## Specifications

### Wetted Materials:

- 316L Stainless Steel body and electrodes
- PVDF Insulator
- O-rings: FPM standard, EPDM, Kalrez® optional
- Cable: 4-cond + shield, PVC jacket (Fixed cable models)
- Watertight rubber cable assembly w/NEMA 6P connector (Submersible cable models)

### Power Requirements

- 4 to 20 mA: 24 VDC nominal, 22.1 mA maximum (21.6 VDC min. to 26.4 max.)  
400 mV p-p maximum ripple voltage
- Frequency: 5 to 24 VDC nominal, 15 mA maximum (5 VDC min. to 26.4 VDC max.)
- Digital (S<sup>3</sup>L): 5 VDC nominal, 15 mA maximum (5 VDC min. to 6.5 VDC max.)
- Reverse polarity and short circuit protected

### Performance

- Pipe size range: 2 in. to 48 in.
- Minimum Flow Range 0.05 m/s (0.15 ft/s)  
Maximum Flow range: 10 m/s (33 ft/s)
- Linearity: ±1% reading + 0.1% of max. range
- Repeatability ±0.5% of reading @ 25°C
- Accuracy: ±2% of measured value (in reference conditions where the fluid is water at ambient temperature, the appropriate upstream and downstream distances are observed, the sensor is inserted at the correct depth and there is a fully developed flow profile which is in compliance with ISO 7145-1982 (BS 1042 section 2.2))
- Minimum Conductivity: 20 µS/cm

### Output Specifications

Current output (4 to 20 mA)

- Programmable and reversible
- Loop Accuracy: 32 µA max. error (@ 25°C @ 24 VDC)
- Temp. drift: ±1 µA per °C max.
- Power supply rejection: ±1 µA per V
- Isolation: Low voltage <48 VAC/DC from electrodes and auxiliary power
- Maximum cable: 300 m (1000 ft.)
- Max. Loop Resistance: 300 Ω
- Error condition: 22.1 mA

Frequency output:

- Compatible with Signet 5075, 5500, 5600, 8550 and 8900
- Max. Pull-up Voltage: 30 VDC
- Short Circuit Protected: ≤30 V @ 0Ω pull-up for one hour
- Reverse Polarity Protected to -40 V for 1 hour
- Overvoltage Protected to +40 V for 1 hour
- Minimum Current Sink: 50 mA
- Maximum cable: 300 m (1000 ft.)

Digital (S<sup>3</sup>L) Output:

- Compatible with Signet 8900
- Serial ASCII, TTL level 9600 bps
- Maximum cable: Application dependent (See 8900 manual)

### Tests, Approvals & Standards

- CE
- EN 61326 Emissions and Immunity for Control Equipment  
Immunity: EN 61000-6-1  
Emissions: EN 55011 class B

### Environmental

- NEMA 4 / IP65 (Fixed cable models only)
- NEMA 6P / IP68 (Submersible cable models only)
- Storage Temperature: -15°C to 70°C (5°F to 158°F) (non-icing conditions)
- Operating Temperature (non-icing conditions)  
Ambient: -15°C to 70°C (5°F to 158°F)  
Media: -15°C to 85°C (5°F to 185°F)
- Max. operating pressure: 20.6 bar @ 25°C (300 psi @ 77°F)

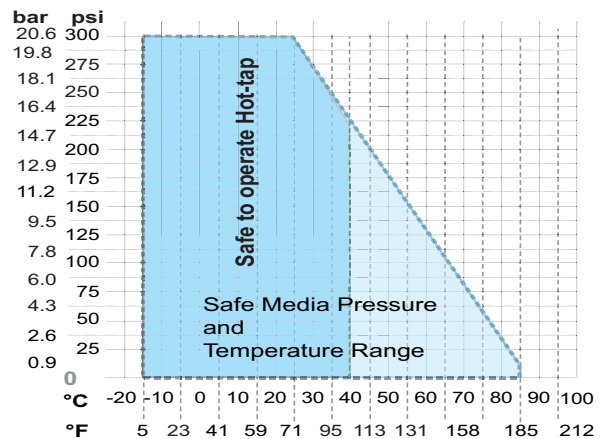

## Selecting a Location

- The 2552 requires a fully developed turbulent flow profile for accurate measurement.
- If the piping system harbors air pockets or bubbles, locate the sensor so the air pockets will not contact the electrodes.
- New magmeters should be allowed to soak in a full pipe for 24 hours before operation.
- 2552 Magmeters equipped with the submersible cable are rated NEMA 6P (IP68). These units can withstand submersion to depths no greater than 2 m (6 ft.) for prolonged periods.
- 2552 Magmeters with fixed cables are rated NEMA 4 / IP65. They are NOT suitable for submersion.

Select a location with sufficient distance of straight pipe immediately upstream of the sensor.

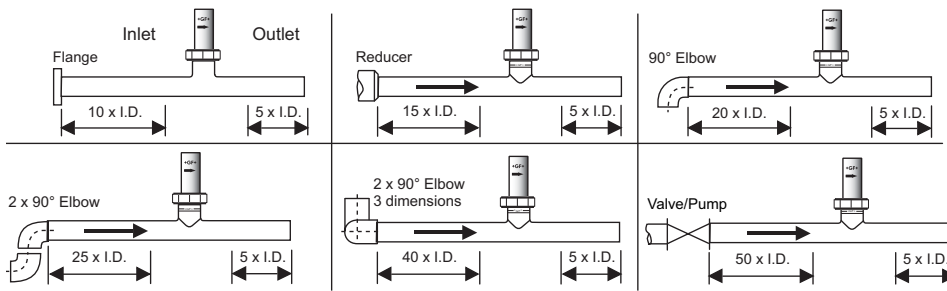

Locating the sensor in a trap or where the flow is upward helps to protect the sensor from exposure to air bubbles when the system is in operation.

NOTE: The system should be designed to keep the sensor wet at all times.

## Dimensions

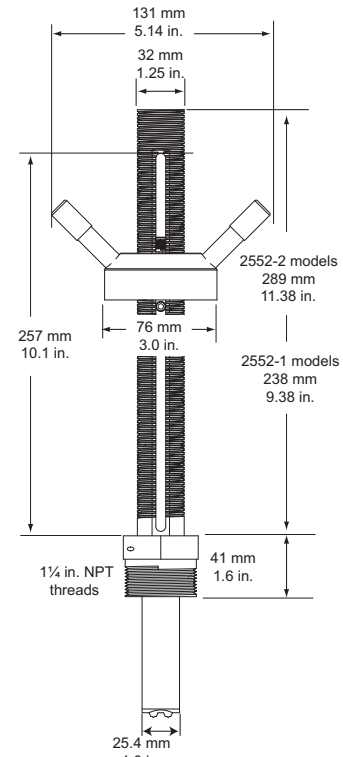

These configurations are not recommended because it is difficult to keep the pipe full.

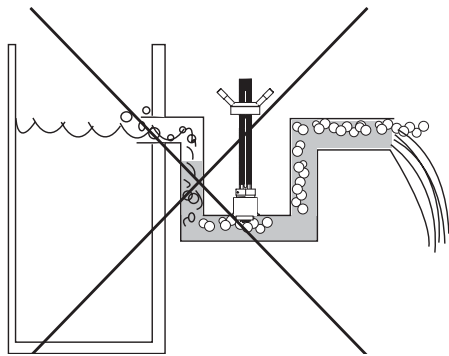
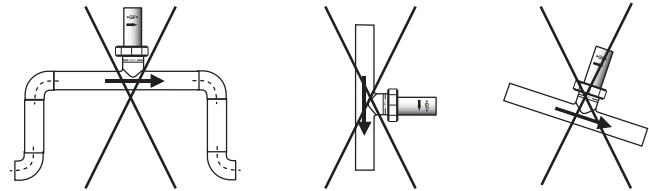
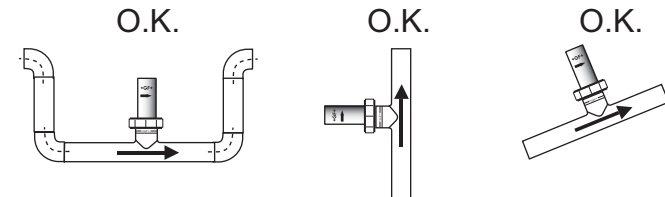

In a gravity-flow system, the tank must be designed so the level does not drop below the outlet.

This causes the pipe to draw air in from the tank. If air bubbles pass across the Magmeter electrodes, the output will become erratic.

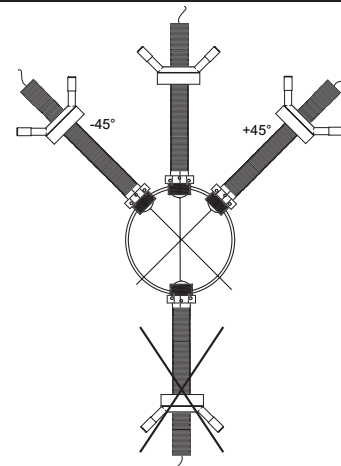

Mounting the sensor upright is OK only where the pipe is full and no air pockets are present at the top of the pipe.

Mount at a maximum of 45° when air bubbles are present.

Do not mount on the bottom of the pipe if sediments are present.

## Standard Magmeter Installation

The following items are required to properly install the Magmeter:

- **Supplied with 2552 Magmeter:**
  - 12-inch Ruler
  - Brass alignment rod
  - H-dimension value for your pipe (See pages 10-11)
  - Hex wrench
  - 2 clamp rings
- **Not supplied:**
  - Female pipe fitting (weld-on or saddle) with 1¼ in. NPT or ISO 7/1-Rc 1¼ threads
  - 32 mm (1¼ in.) diameter drill
  - Pipe thread sealant suitable for application
  - Pipe wrench

### 1. Prepare the pipe:

- Cut a 32 mm (1¼ in.) opening in the pipe.
  - Install a 1¼ inch outlet onto the pipe.
- ⚠ This fitting must withstand pressures up to 20 bar (300 psi).

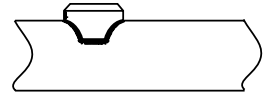

### 2. Install the Magmeter into the pipe

- Apply sealing tape or paste to the male threads of the sensor nut and thread it securely into the pipe fitting.
- ⚠ The sensor is marked to identify the downstream alignment. The arrow MUST point DOWNSTREAM.
- ⚠ Wear gloves to grip the sensor. Hold the sensor securely while threading the sensor nut into the fitting. Do not allow the magmeter cable to become twisted while turning the nut.

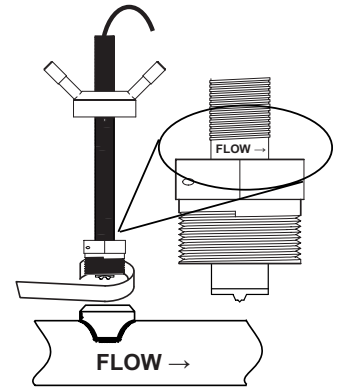

### 3. Adjust the magmeter position and insertion depth

- Find the H-dimension for your specific pipe size on pages 10-11.
  - Insert the brass rod through the alignment opening at the top of the sensor. Adjust the height of the magmeter until:
  - The distance (H) from the OUTSIDE of the pipe to the bottom of the alignment rod is equal to the H-dimension.
  - The alignment rod is parallel to the pipe  $\pm 1^\circ$ .
- ⚠ Misalignment will cause inaccurate measurement.
- A dry lubricant is applied to the threaded column at the factory. If necessary, re-apply a suitable lubricant to the threaded column to facilitate smooth operation.

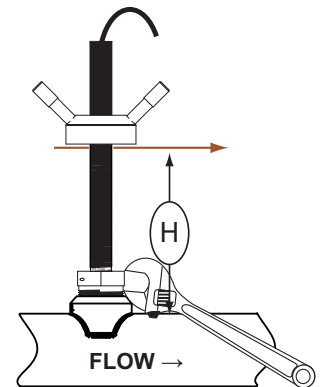
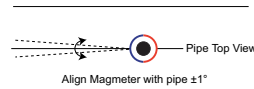

### 4. Secure the Magmeter in position

- Secure the fitting by tightening the set screw on the side of the sensor assembly. A set screw wrench is provided in the magmeter package.
- Secure the height adjustment by installing the two pipe clamps.
  - Spread the clamp apart to wrap it around the threaded stem.
  - Place one clamp immediately above and one clamp immediately below the magmeter adjustment hub.
  - Squeeze the clamp together until it is firmly locked around the threads.

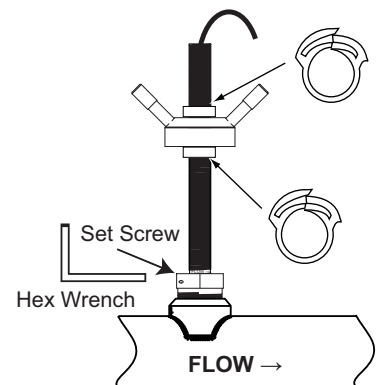

## Hot-tap Magmeter Installation

The following items are required to properly install the Magmeter through a Hot-tap valve:

- |  |  |
|--|--|
| <ul style="list-style-type: none"><li>• <b>Supplied with 2552 Magmeter:</b><ul style="list-style-type: none"><li>• 12-inch Ruler</li><li>• Brass alignment rod</li><li>• Allen wrench</li><li>• 2 clamps</li><li>• H-dimension value for your pipe (See pages 10-11)</li></ul></li></ul> | <ul style="list-style-type: none"><li>• <b>Not supplied:</b><ul style="list-style-type: none"><li>• Female pipe fitting (weld-on or saddle) with 1/4 in. NPT or ISO 7/1-Rc 1/4 threads</li><li>• 32 mm (1 1/4 in.) pipe nipple</li><li>• 32 mm (1 1/4 in.) ball valve</li><li>• 32 mm (1 1/4 in.) drill bit</li><li>• Pipe thread sealant suitable for application</li><li>• Pipe wrench</li></ul></li></ul> |
|--|--|

### 1. Prepare the pipe:

- Install a 1/4 inch outlet onto the pipe.
  - ⚠ This fitting must withstand pressures up to 20 bar (300 psi).
- Thread the 1/4 in. pipe nipple into the outlet. Use a suitable paste or sealing tape to provide a leakproof connection.
- Thread the 1/4 in. ball valve onto the pipe nipple. Position the valve handle so it is parallel to the pipe. This will prevent the valve handle from interfering with the adjustment and alignment of the magmeter.
- **Cut a 32 mm (1 1/4 in.) opening in the pipe.**

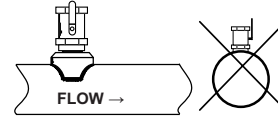
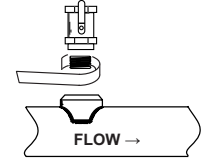
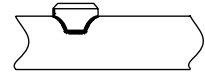

- ⚠ **Hot-tap drilling requires special tools and skills.**  
**This task should only be performed by qualified personnel.**

### 2. Install the Magmeter into the pipe

- Apply sealing tape or paste to the male threads of the sensor nut and thread it securely into the pipe fitting.
  - ⚠ The sensor is marked to identify the downstream alignment. The arrow **MUST** point **DOWNSTREAM**.
  - ⚠ Wear gloves to grip the sensor. Hold the sensor securely while threading the sensor nut into the fitting. Do not allow the magmeter cable to become twisted while turning the nut.

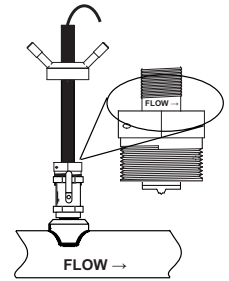
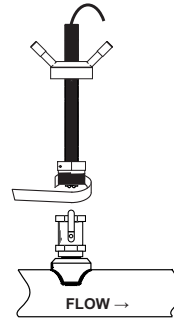

### 3. Adjust the magmeter position and insertion depth

- Find the H-dimension for your specific pipe size on pages 10-11.
- Insert the brass rod through the alignment opening at the top of the sensor. Adjust the height of the magmeter until:
  - The distance (H) from the **OUTSIDE** of the pipe to the bottom of the alignment rod is equal to the H-dimension.
  - The alignment rod is parallel to the pipe  $\pm 1^\circ$ .
- ⚠ Misalignment will cause inaccurate measurement.

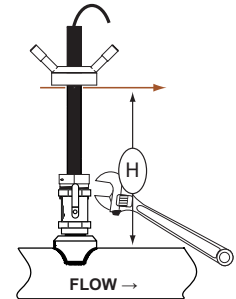

### 4. Secure the Magmeter in position

- Secure the fitting by tightening the set screw on the side of the sensor assembly. A set screw wrench is provided in the magmeter package.
- Secure the height adjustment by installing the two pipe clamps:
  - Spread the clamp apart to wrap it around the threaded stem.
  - Place one clamp immediately above and one clamp immediately below the magmeter adjustment hub.
  - Squeeze the clamp together until it is firmly locked around the threads.

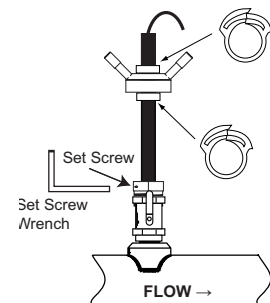

## General Installation and Grounding Tips

### Sensor conditioning

The Magmeter output signal may be unstable immediately after installation. Allowing the sensor to soak in a full pipe (or in any container of water) for 24 hours will stabilize the performance.

- Very low conductivity fluids may require a longer conditioning period. (The Magmeter may not operate properly in fluids where the conductivity is less than 20  $\mu\text{S}/\text{cm}$ .)

### Grounding

The 2552 Magmeter is unaffected by moderate levels of electrical noise, especially if installed in a properly grounded metal piping system. However, in some applications it may be necessary to ground portions of the system to eliminate electrical interference. The grounding requirements will vary with each installation.

One or more of the following steps may be applied if the 2552 Magmeter is affected by electrical noise:

- ① Connect a wire (14 AWG/2.08 mm<sup>2</sup> recommended) from the ground terminal screw on the outside of the sensor nut directly to a local Earth ground.
- ② Install fluid grounding devices immediately upstream and downstream of the Magmeter. Connect the fluid grounds to the Earth ground terminal on the 2552. Use flanged grounding rings or metal electrodes on plastic pipes, or metal clamps on metal pipes. Fluid grounds must be in direct contact with the fluid, and as near to the Magmeter as possible.
- ③ Connect the SHIELD conductor to Earth ground at the instrument.

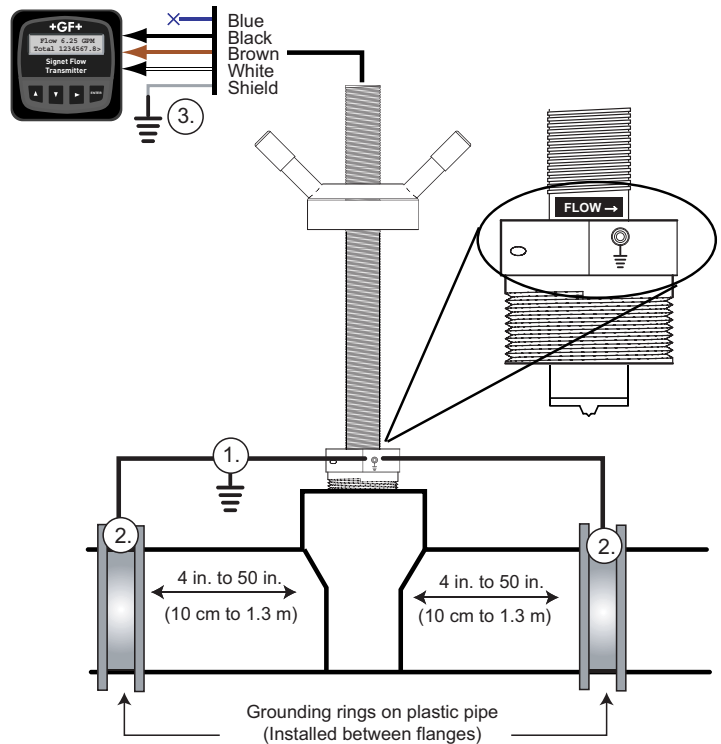

### Bi-Directional Flow

The 2552 magmeter is designed to measure bi-directional flow.

- **4-20 mA output models:** May be scaled to span any flow range: For example: "4 to 20 mA = -100 GPM to +100 GPM"
- **Frequency output models:** Reverse flow is processed same as forward flow.
- **Digital (S<sup>3</sup>L) output models:** Reverse flow results in 0 flow rate displayed on the 8900 Multi-parameter Controller.
- The forward flow direction is indicated at the base of the sensor. The arrow must point DOWNSTREAM.

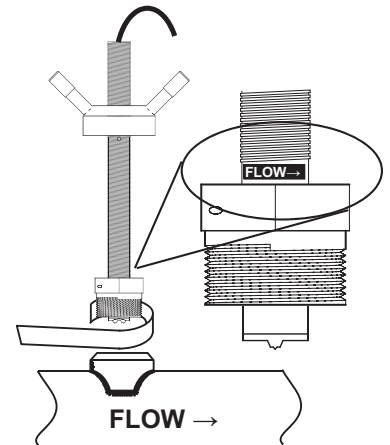

### Removal Instructions

- ⚠ **REDUCE THE PROCESS TEMPERATURE TO LESS THAN 40°C (104°F)**
  - Remove the plastic clamp from the top of the assembly.
  - Turn the sensor nut to the top of the threads to retract the sensor. A light lubricant can be applied to the threads if required.
  - Close the valve.
- ⚠ **Install a LOCKOUT TAG on the closed valve to prevent accidents!**
  - Remove the magmeter from the top of the valve.
  - Loosen the set screw from the sensor adapter fitting.
  - Use one pipe wrench to hold the valve in place while turning the sensor adapter with a second wrench.

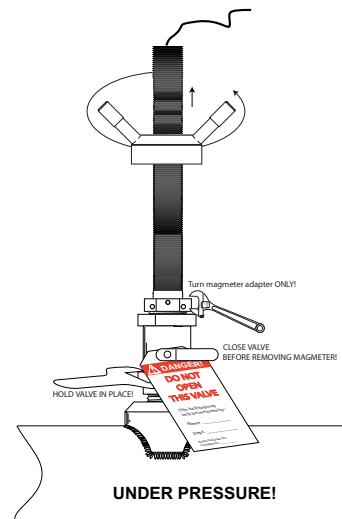

## Wiring the 3-2552 with Frequency or Digital (S<sup>3</sup>L) output

### Wiring: Frequency output (Compatible with all POWERED Signet Flow instruments.)

- The 2552 outputs an open collector frequency signal that can be connected to any powered Signet flow meter. (Models 5075, 5500, 5600, 8550, 8900.)
- DC power is provided to the 2552 Magmeter by all Signet flow instruments. No additional power is required.
- If connecting the 2552 Magmeter to a flow instrument from another manufacturer, 5 to 24 VDC power must be provided to the 2552. A 10 K $\Omega$  pull up resistor must also be connected between the +V (Black) and the Freq. Out (Red) wires

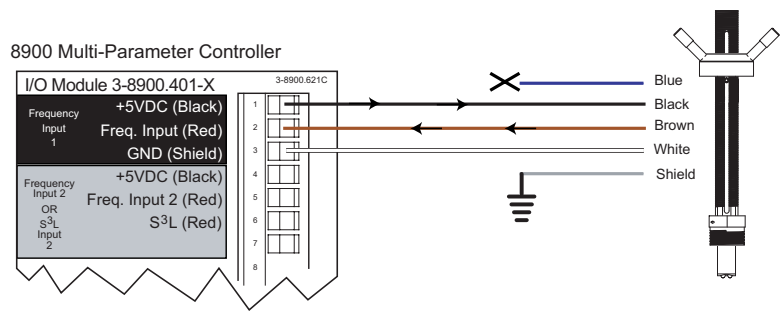

8550-1 Flow Transmitter

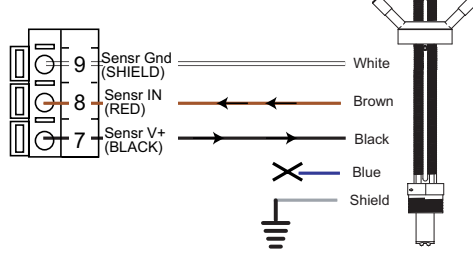

Non-Signet Instrument

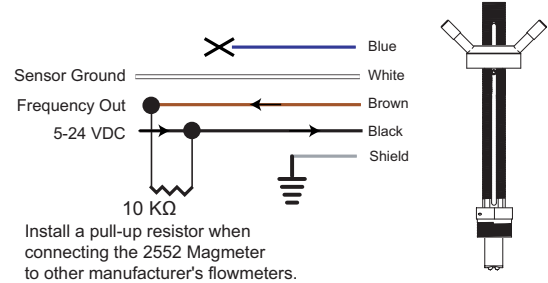

Connect AUX power on the 8550 to provide power for the 2552 output signal.

### Wiring: S<sup>3</sup>L output (Compatible with 8900 Multi-Parameter Controller only)

- The 2552 receives 5 VDC power from the 8900. No additional power is required.

#### NOTE:

The maximum cable length from the 2552 to the 8900 depends on the 8900 configuration. Refer to the 8900 manual for complete information.

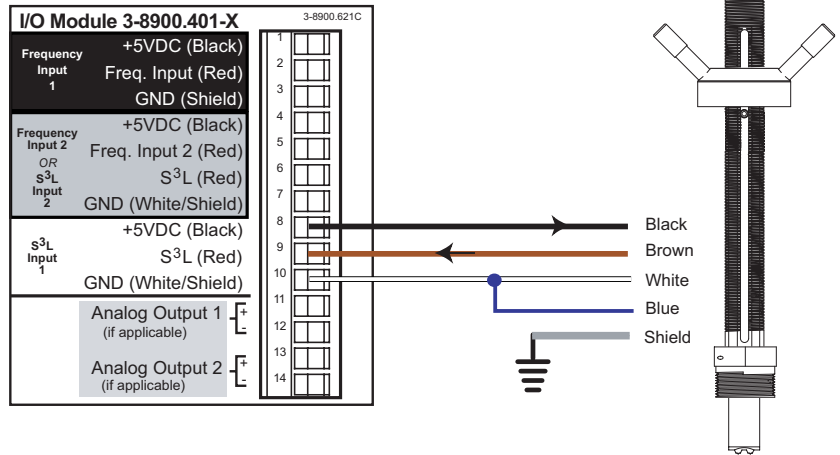

### Wiring the 2552-XX-12 Magmeter with 4-20 mA Loop Output

The 2552 Magmeter is a traditional 2-wire passive 4-20 mA loop transmitter.

- External loop power (24 VDC  $\pm$ 10%) is required. See Ordering Information for power supplies.
- ⚠ The maximum loop resistance the Magmeter can accommodate is 300  $\Omega$ .**
- ⚠ The cable length from the Magmeter to the loop monitor cannot exceed 300 m (1000 ft.).**
- All 2552 Magmeters are shipped from the factory with the 4-20 mA output scaled for 0 to 5 m/s (0 to 16.4 ft/s). If this operating range is suitable, no adjustments are necessary. The calibration charts in this manual list the 20 mA setpoint for each pipe size. Use this information to program the 4-20 mA range of the loop device (PLC, Datalogger, recorder, etc.)

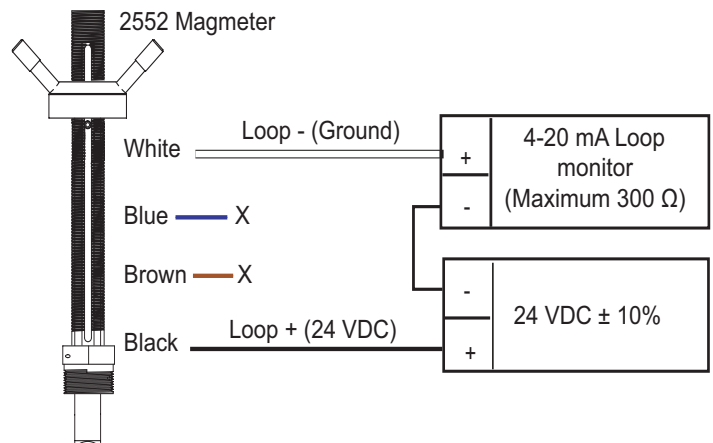

The following page outlines each step in the Magmeter Setup Tool software.

## Custom System Span and Setup

- The 3-0232 Setup tool enables the user to configure the 2552 Magmeter to suit the application.
  - The Setup tool connects the 2552 to a computer by converting the serial data output into standard RS232 format.
  - The computer operating system must be Windows 98, 2000, 2000 Pro, XP, XP Pro ONLY.
  - The 3-0232 Setup tool is not compatible with any other operating system.
  - Managed and network systems may have security measures enabled that interfere with the installation of this program. See the network administrator or IT staff if the program cannot be installed.
- **Collect the Equipment and information that will be required:**
  - 3-0232 Setup Tool (Includes one RS232 Converter and one CD-ROM with software)
  - 24 VDC ISOLATED power source.
  - Personal computer with:
    - Intel Pentium or Higher or AMD 1800 or Higher
    - Windows 98, 2000, 2000 Pro, XP, XP Pro operating system
    - CD ROM Reader capable of reading ISO 9660 Format
    - Free Disk Space Of 400 KB
  - DB9 serial-to-USB converter cable  
(required only for computers that do not have a DB9 serial port available.)
  - Pipe data (id, K-factor from
  - Measurement Preferences (engineering units, timebase)
- **Install the software onto the computer:**
  - 1. Insert the CD-ROM into a computer that is running on Win98, Win2000, or Win XP.
  - 2. Click the START button, then Run. Click the BROWSE button and navigate to the CD drive and select the Setup.exe file. Click Open, then click OK.
  - 3. If unable to install the program, contact the system administrator for assistance.
- **Connect the Magmeter to the computer:**
  - 1. Remove the cover from the Magmeter.
  - 2. Connect the 2552 output terminals 2 and 4 to the input terminals of the RS232 Interface.
  - 3. Connect the isolated 24 VDC power source to the 2552, terminals 1 and 3.
  - 4. Connect the DB9 serial output connector from the RS232 Interface to the computer.
- Note: If the computer does not have an available DB9 serial port, use a serial-to-USB converter cable. Signet recommends cable model USA-19HS by Keyspan. ([www.keyspan.com](http://www.keyspan.com))

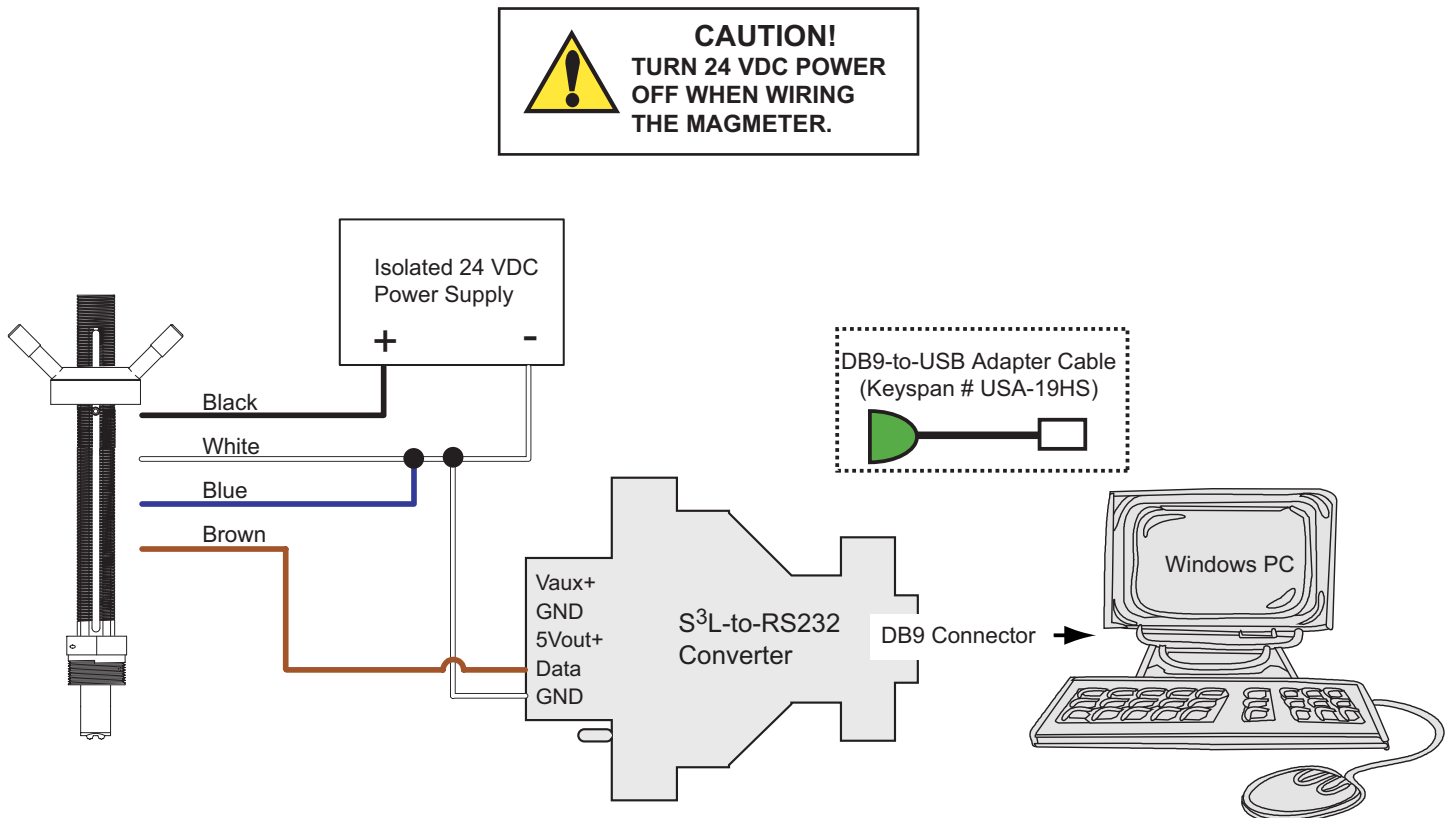

# Using the 3-0232 i-Go S<sup>3</sup>L to RS232 Converter and Setup Tool to customize the 3-2552 Magmeter

## Procedure:

### 1. Set the general information about the pipe and application preferences in the Application Settings fields.

Note: Press the "Restore Factory Settings" button while all fields are blank to load the setup program with factory settings. After a value is entered into any field, the "Restore Factory Settings" button will not change them.

Flow/Velocity Units (factory set: Meters)

- Select the engineering units from the list: meters, feet, cubic meters, liters, cu. ft., U.S. gallons, Imp. gallons.

Timebase (factory set: Seconds)

- Set the timebase preference: seconds, minutes, hours, days

Pipe ID (Inside Diameter) (factory set: 44.0)

- Enter the inside diameter of the pipe.

ID Units: (factory set: millimeters)

- Select inches or mm for the dimensions of the pipe.

NOTE: Check all associated settings after changing the units.

This program does not convert values automatically.

K-Factor (factory set: 65.7665)

- K-factors are published in the Magmeter manual as "pulses per gallon" and "pulses per liter".

### 2. Set the 4-20 mA span (4-20 mA output models only)

- Enter the flow rate at 4 mA. (Factory set: 0 m/s)
- Enter the flow rate at 20 mA. (Factory set: 5 m/s)
- When the RESTORE FACTORY SETTINGS button is pressed, the 20 mA setpoint will be restored to the equivalent of 5 m/s, in terms of the Flow units and Timebase selected above.

### 3. Set the Performance Settings to best accommodate the unique conditions in the pipe.

Averaging Time in Seconds (Factory set: 14 seconds)\*\*

- Select the time the Magmeter will use as the averaging period.

Example: With averaging at 14 seconds, each display is an average of the previous 14 seconds input.

Use higher averaging times to smooth the display and current output where the flow in the pipe is erratic.

Quick Response Sensitivity (Factory set: 25% of Max Range, or 2.5 m/s)\*\*

- Set the percentage of change in the flow rate required to allow the Magmeter to override the AVERAGING and jump to a new flow rate immediately. (2552 maximum range is 10 m/s)

A detailed explanation of **averaging** and **sensitivity** functions is provided on the following page.

Noise Rejection Frequency (Factory set: 60 Hz)\*\*

- Select 50 Hz or 60 Hz according to local AC power specifications.

Low Flow Cut-off (Factory set: 0.05 m/s)

- Set the flow rate where all Magmeter outputs will be forced to zero.

(When the flow rate drops below this value, the frequency output will be 0 Hz. and the current output will be 4 mA.)

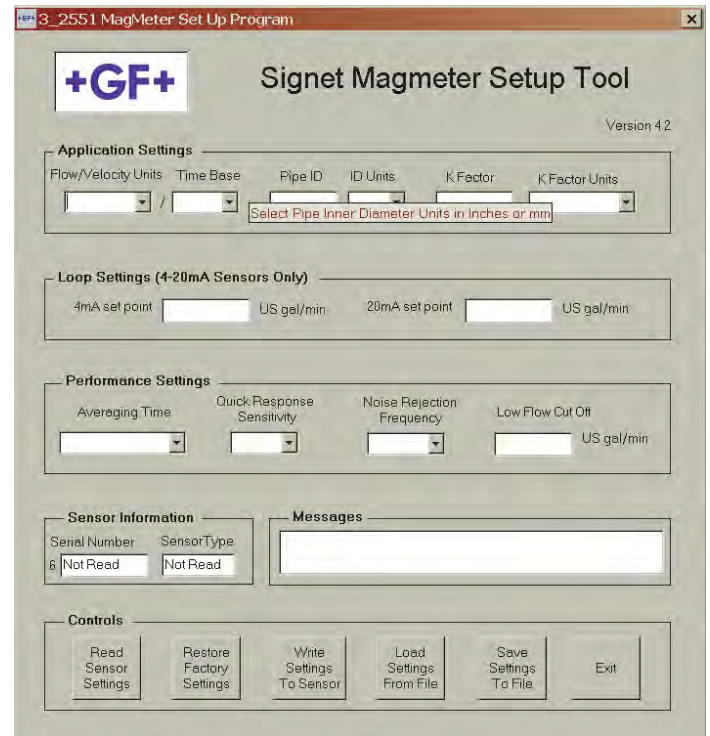

**Note:** If a Low flow Cutoff or a 4-20 mA field turns RED, the value entered is outside of the allowable range. The maximum allowable value will be automatically loaded.

**\*\* SELECT FROM PULL-DOWN MENU ONLY.** Direct text input will not be accepted. Error message will appear: "Cannot write all settings to sensor."

### 4. Click "Write Settings to Sensor" at the bottom of the display to download the new settings to the Magmeter.

- To repeat the same settings in another Magmeter, remove 24 VDC Power to the magmeter and connect the second Magmeter.
- Click "Write Settings to Sensor" again.
- Click "Read Sensor Settings" to validate the new settings.

**Note:** All settings are lost when you exit the program.

## Sensor Information

### Serial Number, Sensor Type:

- Information for these fields is read from the Magmeter when you press the "Read Sensor Settings" button.

## Messages

- Displays messages related to the current selection. Error messages and procedure instructions appear here.

## Controls

- **Read sensor settings:** Read information and setup values from the Magmeter into this setup display.
- **Restore factory settings:** Restores Loop and Performance settings to original factory values. Press this button before entering any data into the program if you want to load all factory settings.
- **Write settings to sensor:** Copies all of the settings in this setup display into the Magmeter.
- **Load settings from file:** Load a saved meter setup file into the Magmeter Setup Tool.
- **Save settings to file:** Save a meter setup file on your local hard drive to be used again.

## 2552 Magmeter Averaging and Sensitivity Settings

Because ideal flow conditions are often impossible to achieve, the flow rate is often erratic, which causes any control features (ie; relays, 4-20 mA loops, etc.) that are associated with the flow rate to also be erratic.

The best solution to these problems is to correct the piping deficiencies that cause the instability. This may involve longer straight runs upstream, reducing the pipe size to maintain a full pipe at all times, and other installation changes. But in many situations these measures are simply not possible.

The 2552 Magmeter provides several tools that are designed to "work around" these deficiencies. They are called "Performance Settings" and can be modified only through the i-Go S<sup>3</sup>L to RS232 Converter and the Magmeter Setup Tool. The noise rejection and the Low Flow Cutoff settings are self-explanatory. The Averaging and the Sensitivity features should be studied before making adjustments.

### Averaging Time in Seconds (Factory set: 14 seconds)

- Set the time the Magmeter will use as the averaging period.  
With averaging at 14 seconds, each display is an average of the previous 14 seconds input.  
Use higher averaging times to smooth the display and current output where the flow in the pipe is erratic.

### Quick Response Sensitivity (Factory set: 25% of Maximum Range, or 2.5 m/s)

- Set the percentage of change in the flow rate required to allow the Magmeter to override the AVERAGING and jump to a new flow rate immediately. (2552 maximum range is 10 m/s)

The pictures below illustrate the effect of these settings.

---

### No AVERAGING, no SENSITIVITY

With AVERAGING set to 0 (zero) the SENSITIVITY is ineffective, and the flow rate may be very unstable. This will cause the output signals to respond erratically.

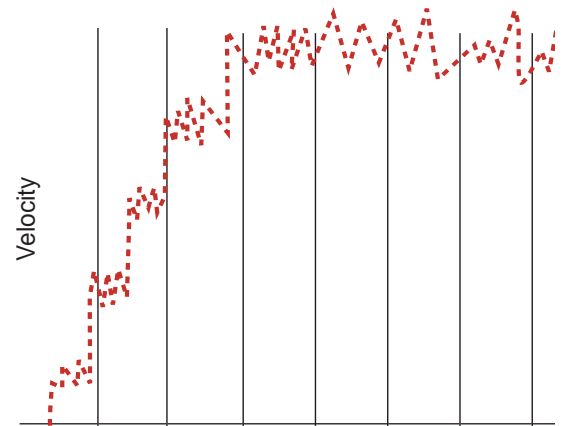

---

### AVERAGING Only

With AVERAGING set to 60 seconds and SENSITIVITY set to 100%, the flow rate is stabilized, but a sharp change in flow rate is not represented for 60 seconds or longer. This can cause system problems if one of the operating setpoints falls within this range.

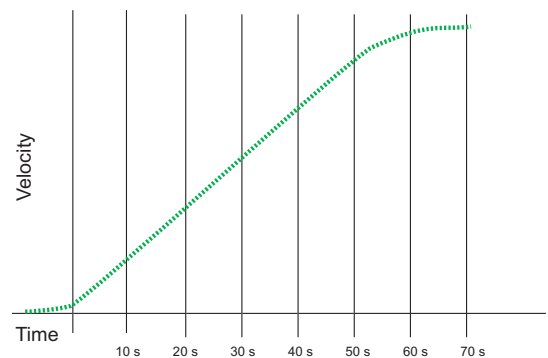

---

### AVERAGING and SENSITIVITY

With AVERAGING at 60 seconds and SENSITIVITY set to 25%, the flow rate is stabilized, but the sudden shift in flow is reflected very quickly.

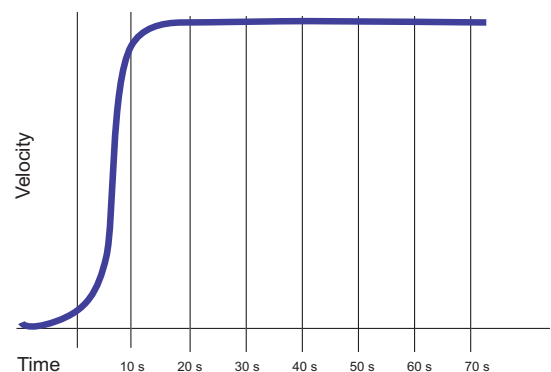

## Calibration Data: K-factors and Full Scale Current Values

The data in this table is based on dimensions of metal pipe per ANSI 36.10 and ANSI 36.19. Stainless steel and carbon steel pipe schedules are the same according to ANSI standards.

Pipe Size (Inch)	Schedule	OD (Inches)	WALL (Inches)	ID (Inches)	H Dim mm -1 Version		H Dim mm -2 Version		K-Factor Pulse/liter	K-Factor Pulse/Gal	Factory set 20 mA (liter/min)	Factory set20 mA (GPM)
					/32 inch	mm	/32 inch	mm				
<b>2</b>	40	2.375	0.15	2.07	8 16/32	216.4	10 16/32	267.0	46.19	174.83	649.5	171.6
	80	2.375	0.22	1.94	8 15/32	215.1	10 15/32	265.9	52.49	198.68	571.5	151.0
<b>2 ½</b>	40	2.875	0.20	2.47	8 14/32	214.1	10 14/32	264.9	32.37	122.54	926.7	244.8
	80	2.875	0.28	2.32	8 12/32	212.6	10 12/32	263.4	36.57	138.42	820.3	216.7
<b>3</b>	40	3.500	0.22	3.07	8 12/32	212.3	10 12/32	263.1	20.97	79.36	1431	378.0
	80	3.500	0.30	2.90	8 10/32	210.6	10 9/32	261.4	23.47	88.82	1278	337.8
<b>3 ½</b>	40	4.000	0.23	3.55	8 10/32	210.8	10 10/32	261.6	15.68	59.34	1914	505.6
	80	4.000	0.32	3.36	8 8/32	208.9	10 8/32	259.7	17.44	66.01	1720	454.5
<b>4</b>	40	4.500	0.24	4.03	8 8/32	209.3	10 8/32	260.1	12.18	46.09	2464	651.0
	80	4.500	0.34	3.83	8 6/32	207.3	10 5/32	258.1	13.48	51.03	2225	587.9
<b>5</b>	40	5.563	0.26	5.05	8 4/32	206.2	10 4/32	257.0	7.748	29.33	3872	1023
	80	5.563	0.38	4.81	8	203.8	10	254.6	8.519	32.25	3521	930.4
<b>6</b>	40	6.625	0.28	6.07	8	203.0	10	253.8	5.365	20.31	5591	1477
	80	6.625	0.43	5.76	7 28/32	200.0	9 28/32	250.8	5.946	22.51	5045	1333
<b>8</b>	40	8.625	0.32	7.98	7 24/32	197.1	9 24/32	247.9	3.098	11.73	9683	2558
	80	8.625	0.50	7.63	7 20/32	193.5	9 20/32	244.3	3.394	12.85	8838	2335
<b>10</b>	40	10.75	0.37	10.0	7 16/32	190.8	9 16/32	241.6	1.966	7.440	15262	4032
	80	10.75	0.59	9.56	7 11/32	186.2	9 11/32	237.00	2.158	8.170	13899	3672
<b>12</b>	STD	12.75	0.38	12.0	7 10/32	185.6	9 10/32	236.4	1.371	5.187	21890	5783
	XHY	12.75	0.50	11.8	7 7/32	183.0	9 6/32	233.8	1.429	5.410	20987	5545
<b>14</b>	30	14.00	0.38	13.3	7 6/32	182.4	9 6/32	233.2	1.124	4.255	26688	7051
	XHY	14.00	0.50	13.0	7 3/32	179.8	9 3/32	230.6	1.168	4.420	25690	6787
<b>16</b>	30	16.00	0.38	15.3	7	177.3	9	228.1	0.849	3.212	35352	9340
	40/ XHY	16.00	0.50	15.0	6 28/32	174.8	8 28/32	225.6	0.877	3.320	34202	9036
<b>18</b>	STD	18.00	0.38	17.3	6 25/32	172.2	8 25/32	223.0	0.663	2.510	45233	11950
	XHY	18.00	0.50	17.0	6 22/32	169.7	8 22/32	220.5	0.683	2.585	43931	11610
<b>20</b>	20/ STD	20.00	0.38	19.3	6 18/32	167.1	8 19/32	217.9	0.533	2.016	56330	14880
	30/ XHY	20.00	0.50	19.0	6 16/32	164.6	8 16/32	215.39	0.547	2.069	54876	14500
<b>22</b>	20/ STD	22.00	0.38	21.3	6 12/32	162.1	8 12/32	212.85	0.437	1.654	68643	18136
	30/ XHY	22.00	0.50	21.0	6 9/32	159.5	8 9/32	210.31	0.448	1.694	67037	17711
<b>24</b>	20/ STD	24.00	0.38	23.3	6 6/32	157.0	8 6/32	207.77	0.365	1.382	82172	21710
	XHY	24.00	0.50	23.0	6 3/32	154.4	8 3/32	205.23	0.373	1.412	80414	21246

Pipe Size (Inch)	Schedule	OD (Inches)	WALL (Inches)	ID (Inches)	H Dim -1 Version		H Dim -2 Version		K-Factor Pulse/liter	K-Factor Pulse/Gal	Factory set 20 mA (liter/min)	Factory set 20 mA (GPM)
					/32 inch	mm	/32 inch	mm				
26	STD	26	0.38	25.25	6	151.89	8	202.69	0.310	1.172	96917	25606
	20/XHY	26	0.50	25.00	5 28/32	149.35	7 28/32	200.15	0.316	1.195	95008	25101
28	STD	28	0.38	27.25	5 25/32	146.81	7 25/32	197.61	0.266	1.006	112879	29823
	20/XHY	28	0.50	27.00	5 22/32	144.27	7 22/32	195.07	0.271	1.025	110817	29278
30	STD	30	0.38	29.25	5 19/32	141.73	7 19/32	192.53	0.231	0.873	130056	34361
	20/XHY	30	0.50	29.00	5 16/32	139.19	7 16/32	189.99	0.235	0.888	127842	33776
32	STD	32	0.38	31.25	5 12/32	136.65	7 12/32	187.45	0.202	0.765	148449	39220
	20/XHY	32	0.50	31.00	5 9/32	134.11	7 9/32	184.91	0.205	0.777	146084	38595
34	STD	34	0.38	33.25	5 6/32	131.57	7 6/32	182.37	0.179	0.676	168059	44401
	20/XHY	34	0.50	33.00	5 3/32	129.03	7 3/32	179.83	0.181	0.686	165541	43736
36	STD	36	0.38	35.25	5	126.49	7	177.29	0.159	0.601	188885	49903
	20/XHY	36	0.50	35.00	4 28/32	123.95	6 28/32	174.75	0.161	0.610	186215	49198
38	STD	38	0.38	37.25	4 25/32	121.41	6 25/32	172.21	0.142	0.538	210926	55727
	XHY	38	0.50	37.00	4 22/32	118.87	6 22/32	169.67	0.144	0.546	208105	54981
40	STD	40	0.38	39.25	4 19/32	116.33	6 19/32	167.13	0.128	0.485	234184	61872
	XHY	40	0.50	39.00	4 16/32	113.79	6 16/32	164.59	0.130	0.491	231210	61086
42	STD	42	0.38	41.25	4 12/32	111.25	6 12/32	162.05	0.116	0.439	258658	68338
	XHY	42	0.50	41.00	4 9/32	108.71	6 9/32	159.51	0.117	0.444	255532	67512
48	STD	48	0.38	47.25	3 25/32	96.01	5 25/32	146.81	0.088	0.335	339377	89664
	XHY	48	0.50	47.00	3 22/32	93.47	5 22/32	144.27	0.089	0.338	335795	88717

**Installation instructions for other pipes**

If your pipe is not listed in the tables, you can calculate the proper H-dimension as illustrated here.

Contact the factory for a custom K-factor.

The Sensor Height:                    225.5 mm    ( 8.88 in. )  
 Subtract the Wall Thickness:        \_\_\_\_\_ mm    ( \_\_\_\_ in. )  
 Subtract 10% of pipe id:            \_\_\_\_\_ mm    ( \_\_\_\_ in. )  
 The new H dimension =                \_\_\_\_\_ mm    ( \_\_\_\_ in. )

**Note: 1 in. = 25.4 mm**

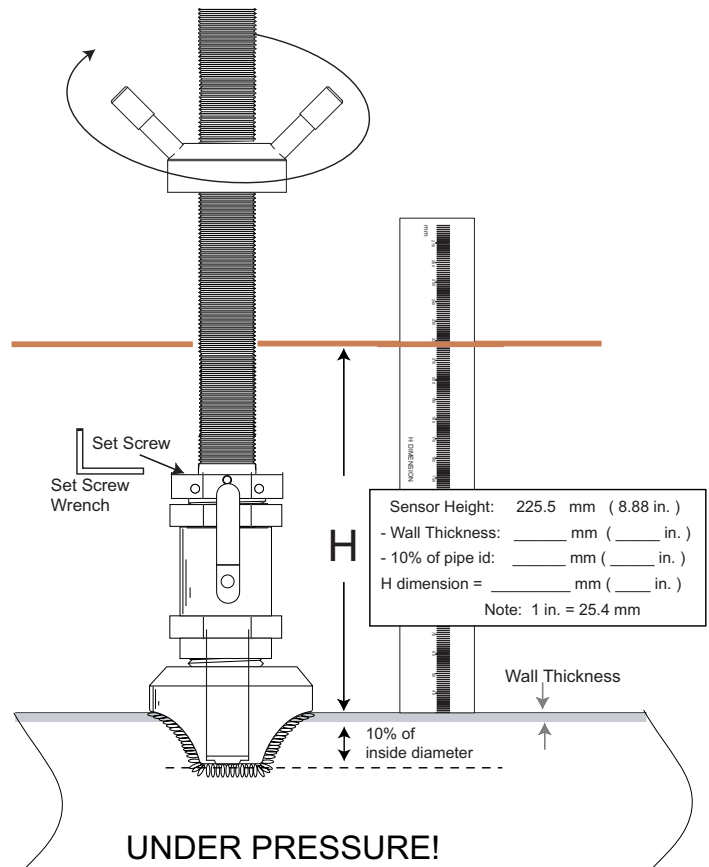

## Maintenance

There are no user-serviceable components in the Magmeter.

- If the fluid contains deposits and solids that may coat the electrodes, a regular cleaning schedule is recommended.
- Do not use abrasive materials on the metal electrodes. Clean with soft cloth and mild detergent only.
- Use a cotton swab and mild detergent to remove deposits on the metal electrodes at the tip of the sensor.
- If the sensor nut will not turn smoothly, a light lubricant can be applied to the threads.

## Environmental Recommendations:

- When used properly, this product presents no inherent danger to the environment.
- Please follow local ordinance when disposing of this or any product with electronic components.

## Troubleshooting

Symptom	Possible Cause	Possible Solution
<ul style="list-style-type: none"> <li>• Frequency, Digital or Current output is erratic.</li> </ul>	<ul style="list-style-type: none"> <li>• Magmeter installed too close to upstream obstruction.</li> <li>• Magmeter electrodes are coated with solids.</li> <li>• Magmeter electrodes exposed to air bubbles/pockets.</li> <li>• Electrical noise is interfering with the measurement.</li> <li>• New sensor, metal surface not properly conditioned.</li> </ul>	<ul style="list-style-type: none"> <li>• Move the Magmeter upstream at least 10 pipe diameters from obstruction.</li> <li>• Clean the electrodes with soft cloth. Do not use abrasives.</li> <li>• Eliminate air bubbles in the pipe.</li> <li>• Remove the Magmeter and reinstall with the flow direction arrow on the sensor body pointed DOWNSTREAM.</li> <li>• Modify grounding as required to protect the Magmeter from interference.</li> <li>• Soak sensor overnight in fluid.</li> </ul>
<ul style="list-style-type: none"> <li>• Output is not 0 when flow is stopped.</li> </ul>	<ul style="list-style-type: none"> <li>• Electrodes not adequately conditioned.</li> <li>• Pipe is empty, Magmeter is not in fluid.</li> <li>• Electrical noise is interfering with the measurement.</li> <li>• Defective Magmeter</li> </ul>	<ul style="list-style-type: none"> <li>• Soak sensor overnight in fluid.</li> <li>• Configure pipe so electrodes are always in fluid.</li> <li>• Modify grounding as required to protect the Magmeter from interference.</li> <li>• Adjust low flow cutoff higher.</li> <li>• Return to factory for service.</li> </ul>
<ul style="list-style-type: none"> <li>• 4-20 mA output is incorrect.</li> </ul>	<ul style="list-style-type: none"> <li>• 4-20 mA is not scaled same as Loop device.</li> <li>• Loop device is not scaled same as Magmeter.</li> <li>• Defective Magmeter</li> </ul>	<ul style="list-style-type: none"> <li>• Use 3-0232 Span and Setup tool to set output range.</li> <li>• Respan Loop device to match Magmeter.</li> <li>• Return to factory for service.</li> </ul>
<ul style="list-style-type: none"> <li>• Frequency output is inoperative</li> <li>• Digital (S<sup>3</sup>L) output is inoperative.</li> <li>• Loop output is inoperative.</li> </ul>	<ul style="list-style-type: none"> <li>• 2552 is wrong model.</li> <li>• Wiring is not correct.</li> <li>• Frequency input to other manufacturer's flow instrument does not have pull-up resistor.</li> </ul>	<ul style="list-style-type: none"> <li>• Freq/S<sup>3</sup>L model is 3-2552-XX-11.</li> <li>• Blue wire must be grounded for freq out, open for S<sup>3</sup>L out.</li> <li>• 4-20 mA model is 3-2552-XX-12.</li> <li>• Check wiring, make corrections.</li> <li>• Install 10kΩ resistor.</li> </ul>
<ul style="list-style-type: none"> <li>• Output is 22.1 mA.</li> </ul>	<ul style="list-style-type: none"> <li>• Conductivity is less than 20 μS/cm.</li> <li>• Electrical noise</li> <li>• Electronic component failure.</li> </ul>	<ul style="list-style-type: none"> <li>• Unsuitable application for Magmeter.</li> <li>• Check grounding, eliminate noise source</li> <li>• Return to factory for service.</li> </ul>

## Troubleshooting with the RED and BLUE lights

The 2552 uses two colored LEDs to indicate the status of the measurement. They are located at the top of the magmeter, recessed inside the threaded steel housing. Look down the tube to see them.

No Lights:	The power is off or the sensor is not connected
Solid Blue:	The power is on but there is no flow in the pipe.
Blinking Blue:	Normal operation, blink rate is proportional to the flow rate.
Alternating Red-Blue:	Empty pipe indication (electrodes are not wet.)
Blinking Red:	System errors (electrical noise interference)
Solid Red:	Instrument error (defective electronics component)

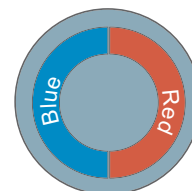







## Ordering Information

Model 2552 Metal Magmeter Ordering Matrix					
3-2552	Mounting Depth Options - Choose One*				
↓	-1	Sensor protrusion depth = 7.3 inches			
	-2	Sensor protrusion depth = 9.3 inches			
	↓	Process Connection Options - Choose One			
		1	1¼ inch NPT Process Connection Threads		
	↓	2	1¼ inch ISO Process Connection Threads		
		Cable and Connector Options - Choose One			
	↓	-A	Fixed Cable, 7.6 m (25 ft); no connector		
		-B	Watertight sensor connector; cable sold separately		
	↓	Output options - Choose One			
		-11	Frequency or Digital (S <sup>3</sup> L)		
		-12	4 to 20 mA output		
	3-2552	-1	1	-A	-12

Mfr. Part No.	Code	Mfr. Part No.	Code
3-2552-11-A-11	159 001 505	3-2552-21-A-11	159 001 513
3-2552-11-A-12	159 001 506	3-2552-21-A-12	159 001 514
3-2552-11-B-11	159 001 507	3-2552-21-B-11	159 001 515
3-2552-11-B-12	159 001 508	3-2552-21-B-12	159 001 516
3-2552-12-A-11	159 001 509	3-2552-22-A-11	159 001 517
3-2552-12-A-12	159 001 510	3-2552-22-A-12	159 001 518
3-2552-12-B-11	159 001 511	3-2552-22-B-11	159 001 519
3-2552-12-B-12	159 001 512	3-2552-22-B-12	159 001 520

## Accessories and Replacement Parts

Mfr. Part No.	Code	Description
2120-1512	159 001 425	1½ x 1¼ inch NPT adapter
2120-2012	159 001 426	2 x 1¼ inch NPT SS adapter
3-2552.392	159 001 530	Kit: 1¼ in. full port, SS ball valve and 1¼ in. nipple
3-2552.393	159 001 531	Kit: 1¼ in. full port, brass ball valve and 1¼ in. nipple
3-2552.394	159 001 532	½ in. NPT conduit adapter, aluminum
4301-2125	159 001 533	1¼ in. NPT, female to female full port ball valve, brass
4301-3125	159 001 387	1¼ in. NPT, female to female full port ball valve, stainless steel
3-0232	159 000 865	RS232 set-up tool (PC compatible)
5541-4184	159 001 388	4-conductor, 22 AWG, water-tight connector, 4m (13 ft)
5541-4186	159 001 389	4-conductor, 22 AWG, water-tight connector, 6m (19.5 ft)
special order	special order	4-conductor, 22 AWG, water-tight connector, customer specified length



George Fischer Signet Inc., 3401 Aerojet Avenue, El Monte, CA 91731-2882 U.S.A. • Tel. (626) 571-2770 • Fax (626) 573-2057  
 For Worldwide Sales and Service, visit our website: [www.gfsignet.com](http://www.gfsignet.com) • Or call (in the U.S.): (800) 854-4090

